

Tribhuvan University
Institute of Engineering
Pulchowk Campus
Pulchowk, Lalitpur



Course Manual
On
Water Supply
(IIIrd Year/Ist Part)

Arun Prasad Parajuli

Rajni Manoj Dhas.

CHAPTER 1 INTRODUCTION

85
1.1 OBJECTIVES OF WATER SUPPLY

The main objective of water supply is to bring water from the source and supply safe water to the consumers in adequate quantity efficiently at low cost. An organized water supply system has following objectives:

- To supply safe and wholesome water.
- To supply safe and reliable and adequate supply.
- To make water available within easy reach of the consumers.
- To supply water rich in reliability, quality, quantity in effective and efficient way so that the general cleanness is obtained and the water related diseases are greatly reduced.

e. To save water fetching time so that the time will be utilized in income generating work.

1.2 IMPORTANCE AND NECESSITY OF WATER SUPPLY SCHEMES

- Basic needs of each and every human being are air, water, heat, light, food shelter and clothes. Except shelter and clothes plants also need other things. Among all above needs Pinder said 'Best of all is water' after air.
- Human can survive without food, shelter and clothes for several days but can't without water. Air and water are the natural gift. Animals and plants can't survive without water.
- Everywhere water is needed for various purposes.
 - For cooking and drinking
 - For bathing and washing
 - For watering lawns and gardens.
 - For heating and air-cooling
 - For growing crops
 - For street washing
 - For fire fighting
 - For recreation in swimming pools, fountains and cascades
 - For power generation and various industrial processes etc.
- Ancient civilization developed along the river banks due to the availability of water for domestic and irrigation purpose.
- In the past, every family was responsible to arrange water.
- After the development of the community, the local sources (such as springs, river, wells etc) are inadequate for drinking and fire fighting etc. Then community started to collect water from the distant large source and conveyed to the community. Clay lead & bore wood were used to convey water.
- As the passage of time due to the increase in population, the pollution in the sources was encountered and trouble of water borne disease arisen then there is the need of treatment.

- Hence there is a need of systematic and well-organized water supply schemes to supply adequate quantity of safe and wholesome water to consumers for drinking and other purposes.

1.3 IMPACTS DUE TO WATER SUPPLY SYSTEMS

There are two types of impact due to water supply systems:

a. Immediate Impact:

- i. Fetching time (long go & bring) is saved so that this time can be used for other works.
- ii. Improves hygienic condition so that time and money expenses for medicine are saved.
- iii. Safe, reliable, adequate and effective supply is gained.

b. Long Term Impact:

- i. Increases socio-economic activities of individuals, family and then community
- ii. Increases the living standard of the people
- iii. Help in the economic growth of whole nation

1.4 POTABLE, CONTAMINATED AND WHOLESOME WATER

- The rain water is originally pure containing two parts of Hydrogen and one part of Oxygen only by volume but absorbs various gases, dust and other impurities while falling.
- On the way of moving on the ground it carries impurities such as silt, organic, non-organic, minerals impurities, suspended matters etc. These substances not always be harmful but may be useful to human life.
- Hence as per the impurities present in the water, it is termed as follows:

a. Pure water:

It is the water containing two parts of Hydrogen and one part of Oxygen only by volume. It is not good for health.

b. Potable Water:

Water suitable for drinking, having pleasant taste and usable for domestic purpose is called potable water.

c. Polluted Water

It is synonymous to contamination but is the result of contamination. This water contains substances unfit or undesirable for public health or domestic purpose.

d. Contaminated Water

Contamination means containing harmful matter. It is always polluted and unfit for use. Water consisting of microorganisms, chemicals, industrial or other wastes, large numbers of pathogens that cause diseases are called contaminated water.



e. **Infected Water**
Water contaminated with pathogenic organisms is called infected water.

f. **Palatable water:**

It is synonymous to potable water. Water which is well aerated but free from excessive temperature, colour, turbidity, taste and odour and aesthetically acceptable is called palatable water.

शुद्ध

g. **Wholesome Water**

It is the drinkable water, which is neither chemically pure nor contain anything harmful matters to human health but contains useful minerals to the human health.

Requirement of wholesome water::

i. It should be free from radioactive substance, microorganism and disease causing bacteria, objectionable dissolved gases (H_2S etc), harmful salts, objectionable minerals, iron, manganese, lead, arsenic and other poisonous metals.

ii. It should be colourless, and sparkling (स्वच्छ) which may be accepted by public.

iii. It should be tasty, odour-free, soft, cool and cheap in cost.

iv. It shouldn't corrode pipes.

v. It should have dissolved oxygen and free from carbonic acid so that it remains fresh.

vi. It should not be contaminated and doesn't

5 ESSENTIALS OF WATER SUPPLY ENGINEERING cause water born diseases

The essentials of water supply scheme are follows:

a. **Source:** It should be selected in such a way that it is reliable and having minimum numbers of impurities.

b. **Intake:** The next step is to construct intake to collect water. Pipe Line to convey water to the treatment plant called transmission.

c. **Treatment plants:** For the treatment of water. The treatment process depends upon quality at source and quality to be required. (Optional)

d. **Pipe Line to convey water from treatment plant to the reservoir** also called transmission.

e. **Clear water reservoir:** To reserve the treated water. (Optional)

f. **Distribution system:** Depends upon the elevation of clear water reservoir (Gravity system, Pumping system or Dual system) consisting of pipe networks.

The essentials of water supply engineering are shown in the flow diagram [Fig. 1.1 (a) and (b)]

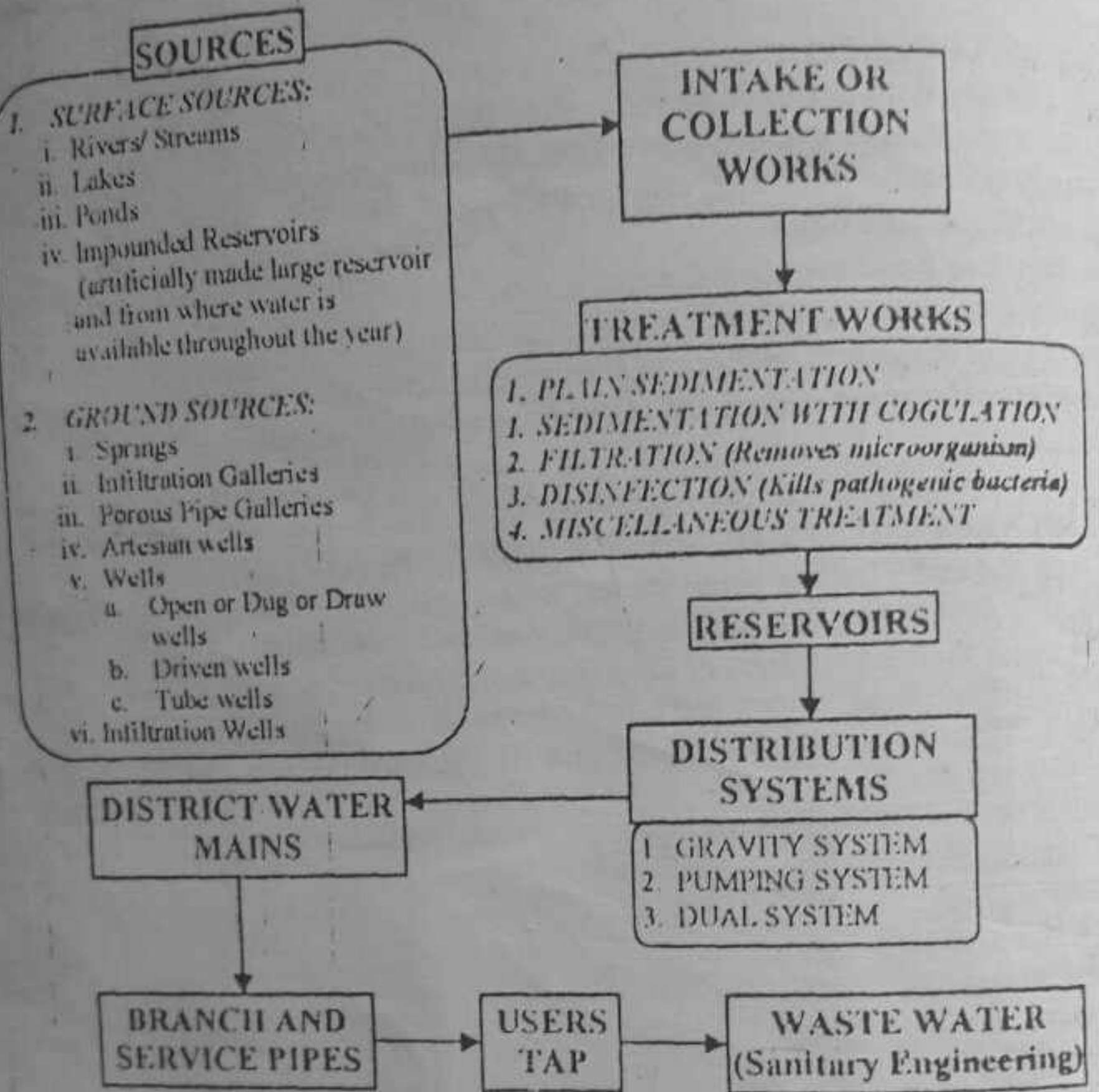

Fig. 1.1(a) Flow Diagram on Essentials of Water Supply Engineering

The above essential components can be summarized as:

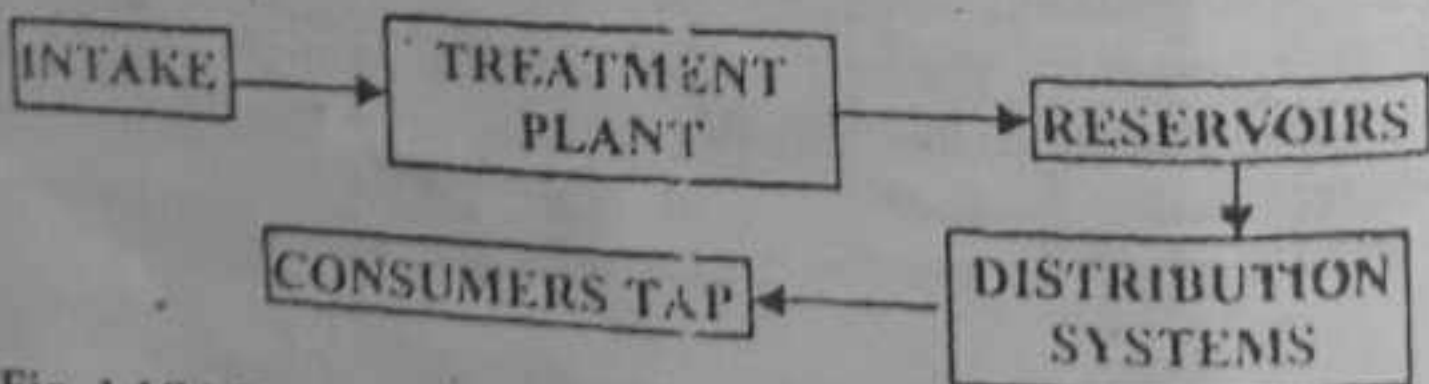

Fig. 1.1(b) Typical Flow Diagram on Essentials of Water Supply Engineering

1.6 TYPICAL COMPONENTS OF WATER SUPPLY SCHEMES

The components of water supply scheme depend upon the system of supply. There are three systems of supply as:

- distrib.
- (A) GRAVITY FLOW SYSTEM (B) PUMPING SYSTEM (C) Dual system**

a. In Rural Areas: Generally in rural area gravity system is followed. It means that the flow is under the gravity. Normally, no pumps (sometimes pump at intake only) are required.

COMPONENTS OF A TYPICAL GRAVITY FLOW SYSTEM

- ① Source (Intake)
- ② Collection chamber
- ③ Interception chamber

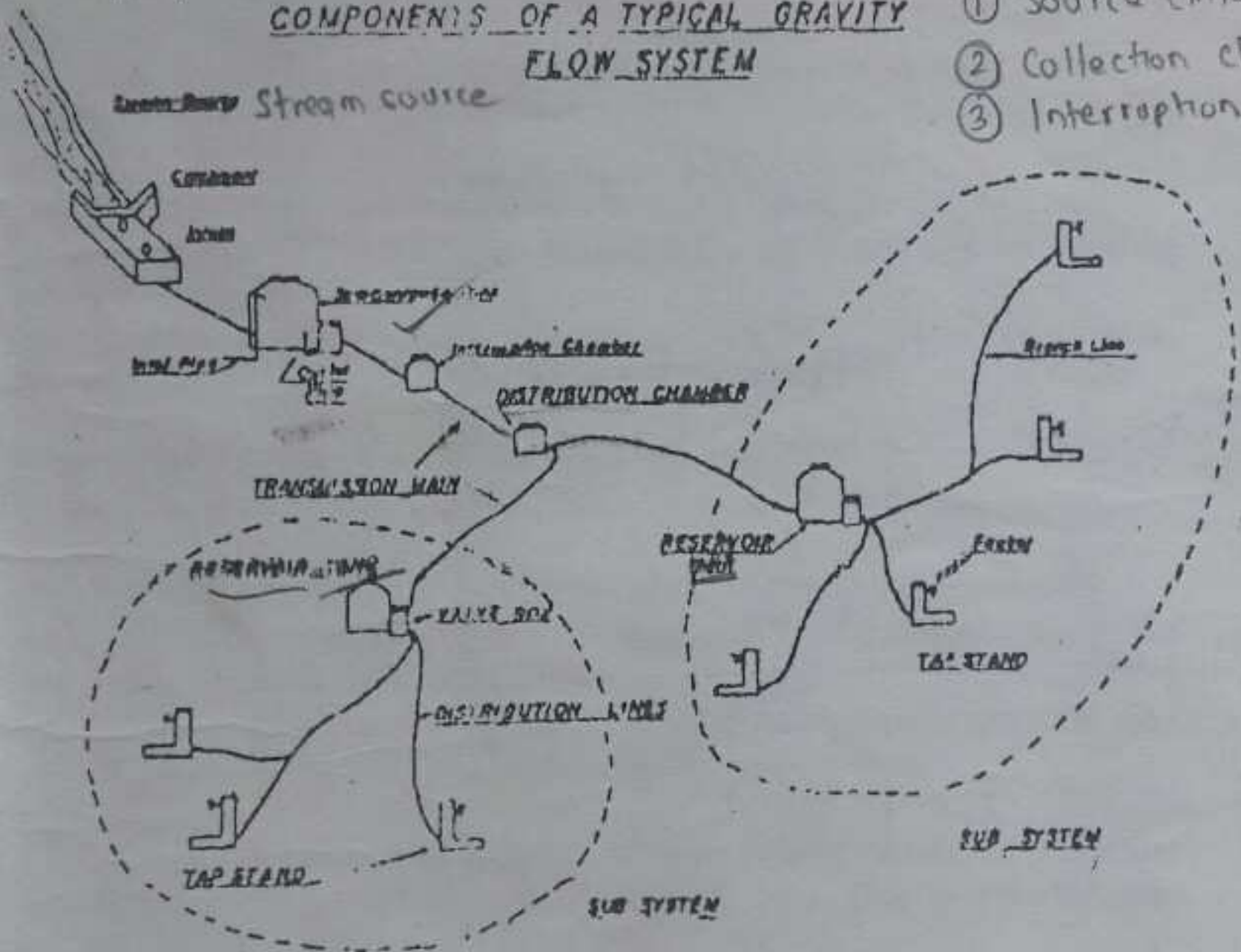

b. In Urban Areas:

Gravity, pumping as well as dual system can be followed in urban area and the components depend upon the topography. However it may consist the following units:

- i. Collection Works: May include ^{Perennial or not} intake works and storage. Depending upon river a dam and storage may be constructed or direct intake can be made.
- ii. Transmission works: In many cases water supply schemes are far away from the city and water should be conveyed to it through

transmission works. It is the connection between collection and

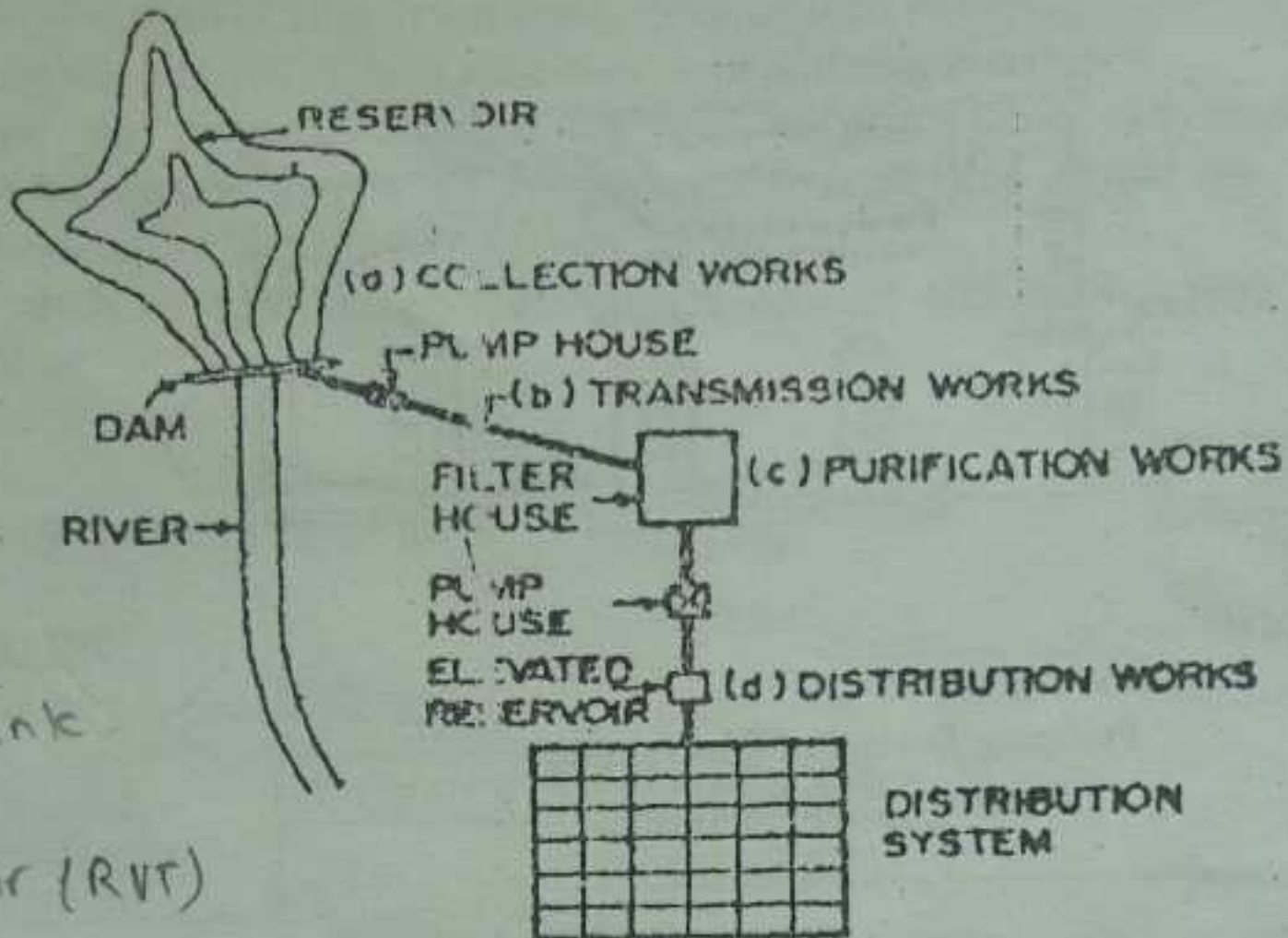

Typical Components of Urban water Supply System

- iii. Purification works: through conduits, pipes, canal aqueduct etc. It is required to treat water for required quality. The process depends upon the quality at source and quality to be required.
- iv. Distribution system: It is required to convey purified water from clear water reservoir to the users by any system of distribution such as dead end pattern and grid iron pattern. Characteristic

A. GRAVITY FLOW SYSTEM

may be as following.

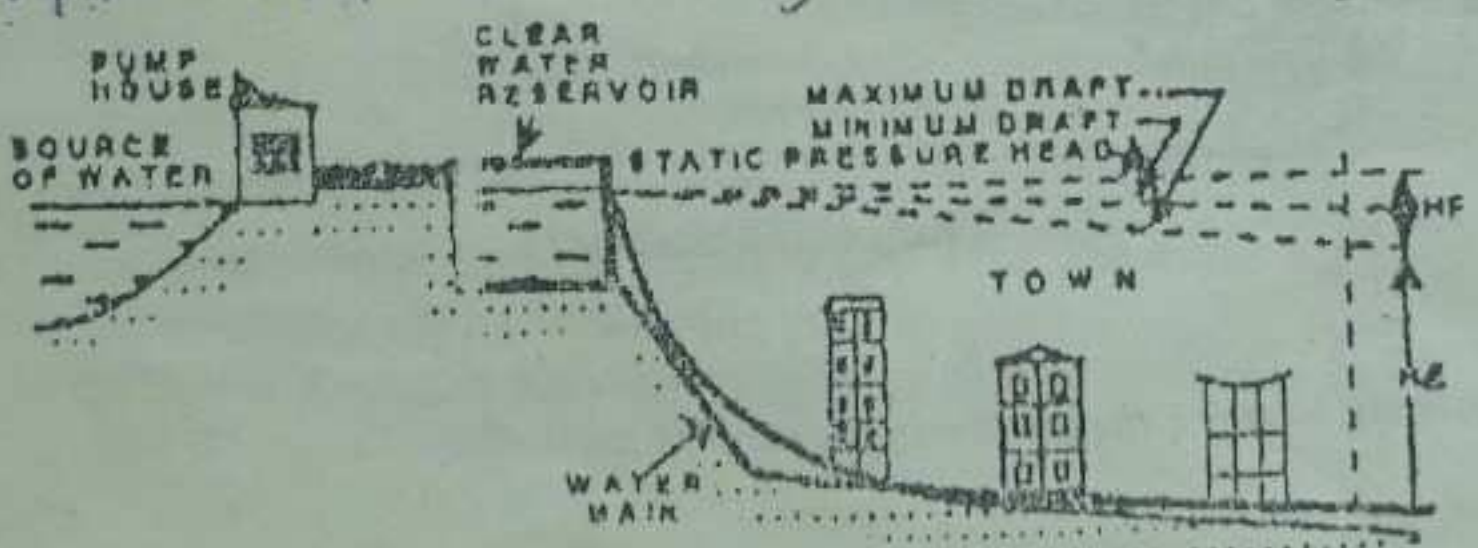

Gravity System of Distribution

B. PUMPING SYSTEM:

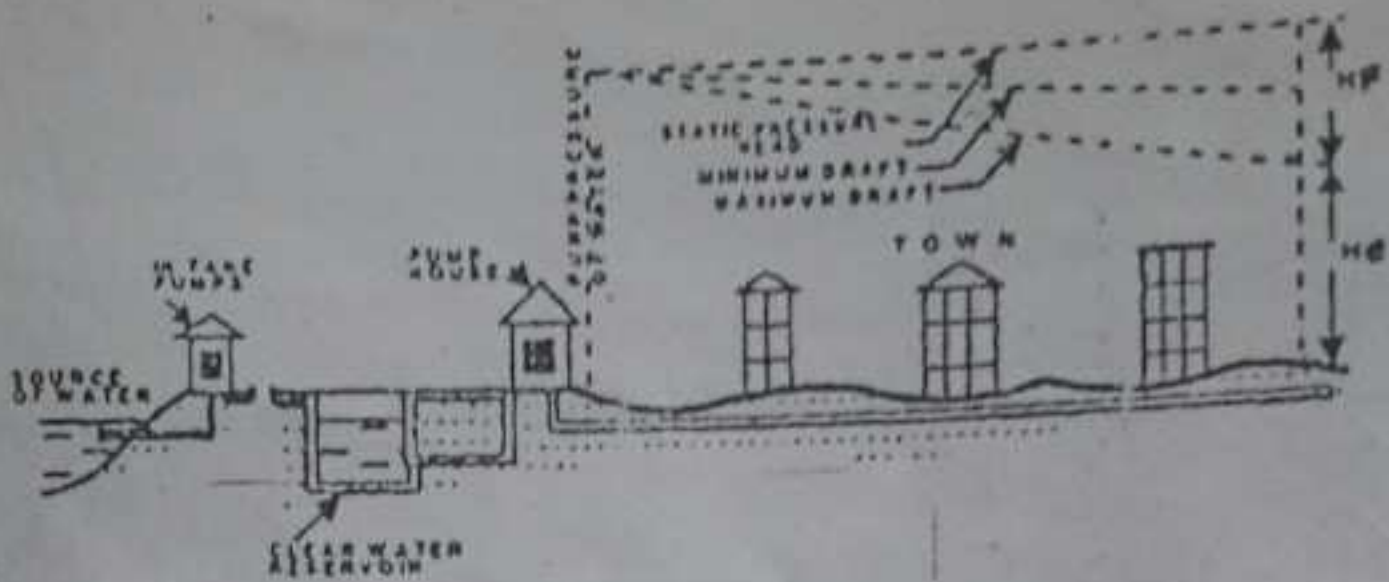

Pumping System of Distribution

2. DUAL SYSTEM:

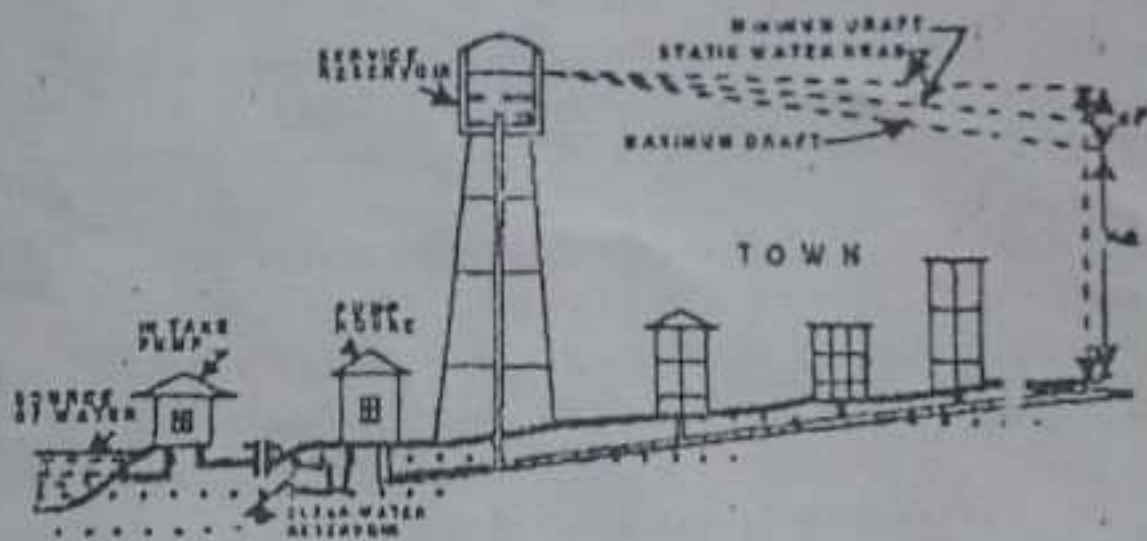

Dual System of Distribution

Note: It is not compulsory to have the above components actually.



CHAPTER 2 SOURCES OF WATER

INTRODUCTION TO SOURCES OF WATER

- Primarily obtained from rain.
- Water from melting of snow and rain can be easily derived from storm, river etc.
- The percolated water through porous soil reaches to the GWT and this water is hold in the pervious layer is called water bearing strata or aquifer. Below aquifer non-porous and non-permeable layer, which don't allow passing water called aquiclude, is found.
- The surface water can be obtained from the streams, ponds, rivers etc whereas the ground water is obtained by different wells & springs etc and these can be used for water supply schemes.
- Seawater and sewage water after treatment can be used for drinking purpose. First in Windhoek (Africa) purified sewage from tap is supplied for drinking purpose.
- Hence sources of water may be defined as the place from where water is obtained.

ELECTION OF THE SOURCE OF WATER (2.3)

- The selection of the sources of water depends upon the following factors.
 - a. *Location:*
 - ✓ It should be near to the consumer's area or town as far as possible.
 - ✓ There may be either surface or ground sources and the selection of the source depends upon other factors.
 - ✓ Location may be at higher elevation such that required pressure may be obtained and water can be supplied by gravity flow.
 - b. *Quantity of water:*
 - ✓ It should have sufficient quantity of water to meet the demand for that design period in the wet and dry seasons also. Two or more sources can be joined for required quantity.
 - ✓ If possible, there should be sufficient quantity for future extension of the project.
 - c. *Quality of water:*
 - ✓ The water should be safe, and free from pathogenic bacteria, germs, and pollution and so good that water can be cheaply treated (ie. wholesome water). The water quality should be such that it has less quantity of impurity, which further needs less treatment.
 - d. *Cost:*
 - ✓ It should be able to supply water of good quality and quantity at the less cost.

- ✓ The cost depends upon location, ground level of city & source, distance between source & distribution area etc.
- ✓ Gravity system of flow is generally cheaper than pumping.
- ✓ Lesser the impurities, lesser the treatment and cost is reduced.
- ✓ Lesser the distance between the area of distribution and source requires lesser length of conveyance system and lesser no. of appurtenances, which reduces cost.
- ✓ Cost analysis is necessary for various options and suitable one is selected.
- e. Sustainable and safe
- f. Reliable
- g. Non conflict among water users

2.3 TYPES OF SOURCES

Sources of water are classified as follows.

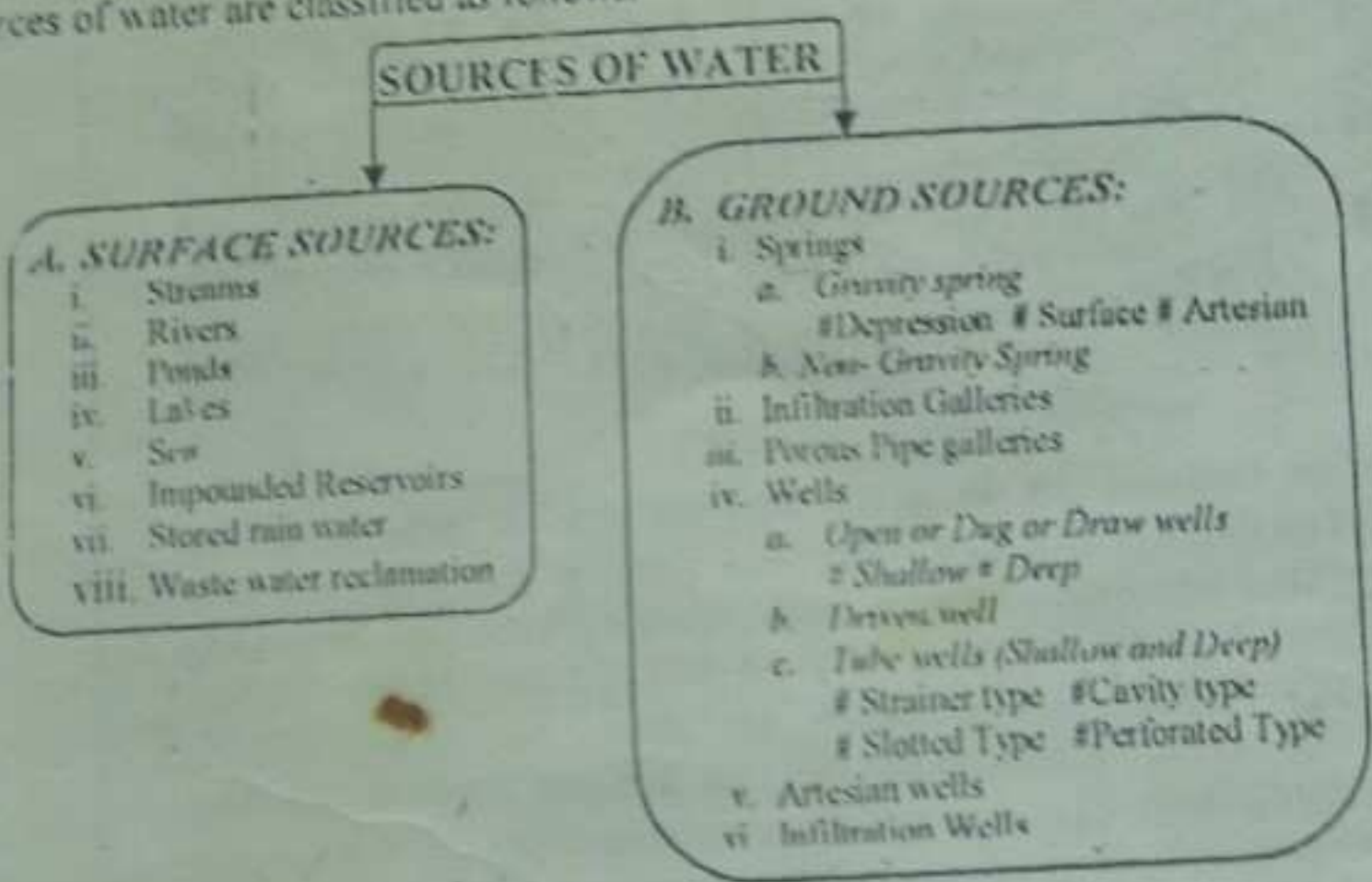

2.4 SURFACE SOURCES 2-1

- Those sources from which water can be obtained easily on the surface of earth eg. streams, lakes, ponds, storage reservoirs etc.
- Quantity may be sufficient & quality may be acceptable & treatment may be required.

*~~cc~~ Streams:

- ✓ Generally streams are formed by surface runoff and discharge is maximum in rainy season and may be dry up in summer called 'Rainy stream'. Some streams are formed by snow melting & springs in such cases water is available at all times and called 'Perennial streams'

Water Supply Engineering

- ✓ Little quantity of water but may have more in rainy period.
- ✓ Quality of water is good except the water from the first runoff but sometimes it contains impurities and can be used after some treatment such as sedimentation.
- ✓ Streams flow in the valley side and it is the main source of water to the village of the hills.

2. Rivers:
- ✓ Rivers are formed by combination of the stream & spring etc from hill

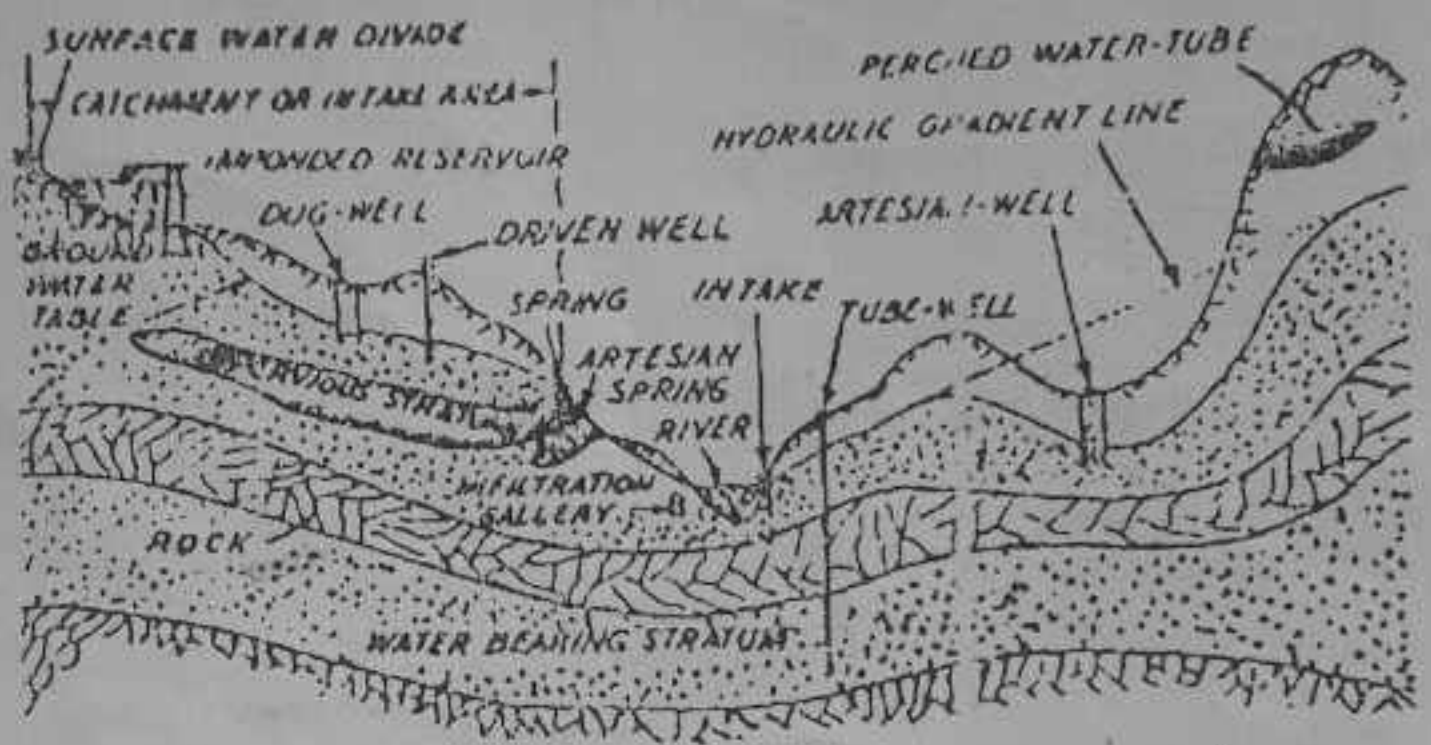

SOURCES OF WATER

to the low land and sea. So in hills they are small & larger in the low land due to the increment of catchments.

- ✓ Rivers may be snowfed, rainfed, partly snowfed & rainfed. Depending upon the water availability of water rivers may be classified into two:
 - i. Perennial Rivers:

Water is available throughout the year and can be used for water supply. eg Snowfed and springfed rivers.
 - ii. Non Perennial Rivers:

Dried on a certain period of the year and generally not used for water supply. If used there is a need of construction of Impound Reservoir. eg Rainfed Rivers.
- ✓ Due to the availability of sufficient quantity of water, ancient towns are developed along the riverbanks.
- ✓ Due to the disposal of sewage, it may be polluted hence necessary care should be taken in selecting intake location. In river self-cleansing occurs otherwise heavy treatment is required.

Large rivers form principal source of water supply scheme for large cities

Chapter 2. Sources of Water

- ✓ Quantity is large in rivers and quality is poor and may need treatment but good in summer & carries silt, clay, sand in monsoon hence this water is used after treatment.
- ✓ Special measurement is required to meet the demand at dry season.

3. Ponds:

- ✓ Temporary type of surface source formed in small natural depressions and artificial depression when the large quantity of excavation is done for constructing highway, bridge, building etc.
- ✓ Surface runoff & the village wastewater flows towards the pond makes the possibility of contamination and quality may be very poor & high degree of treatment is required.
- ✓ It is not the reliable source for water supply due to poor quality & quantity but can be used in animal bathing and irrigation purposes.

4. Lakes:

- ✓ Natural basin with impervious bed in the mountainous region is a lake. It is the permanent type surface source formed in high altitude in between mountains. Eg. Phewa, Rara, Begnas, Tscho Rolpa lakes.
- ✓ The lakes situated in mountainous region of Nepal are of good quality & quantity & may be used in water supply without or after certain treatment. Normally quality is good in large lakes than smaller one.
- ✓ Quantity depends upon the basin capacity, catchment area, annual rainfall, porosity of ground etc.

5. Sea:

- ✓ The water from the ocean can be used as water supply after the high degree of treatment due to presence of salts.
- ✓ It is very costly because pumping system is required.
- ✓ Quantity is more but quality is poor due to presence of salts.

6. Stored Rainwater:

- ✓ In the place where neither ground nor surface water is available, only the rainwater is collected in tanks from roofs of buildings. Eg in Rajasthan, Arabian countries etc.
- ✓ The rainwater is collected in watertight tanks from roofs and pucca courtyard through channels.
- ✓ May contain impurities and may be treated and it cannot used for water supply due to its insufficient quantity.

7. Waste water reclamation:

- ✓ In the place where neither ground nor surface water is available, high degree treated wastewater can be used for the water supply.
- ✓ First in Windhoek (Africa) purified sewage from tap is supplied for drinking purpose.

Supply Engineering

9. Impounding Reservoir:

- ✓ These are the artificial reservoir constructed to store water to meet demand at the dry seasons. The water can be stored by constructing a bund weir or a dam across the river. Eg Sundarjal dam
 - ✓ The dam is constructed across the river in such places where min area of land is submerged, river width is minimum and the reservoir basin remains cup shaped having max possible depth of water.
 - ✓ Hence it defined as the artificial lake created by the construction of a dam across the valley containing a watercourse.
 - ✓ The objective of impound reservoir is to impound or store a portion of stream flow so that it may be used for water supply. The reservoir consists of three parts:
 - i. A dam to hold backwater.
 - ii. A spillway through which excess streamflow may discharged
 - iii. A gate chamber containing the necessary valves for regulating the flow of water from the reservoir.
- The location of the impounded reservoir depends upon the quality and quantity of water available, existence of suitable dam-site, distance and elevation of reservoir, density and distribution of population, geological conditions etc.
- ii. The water quality is same as in the streams and rivers.

GROUND SOURCES

Water Bearing Stratum or Aquifer:

Natural storage reservoir which holds water below the ground from where water can be withdrawn (eg, sand layer).

Aquicludes:

Underground formation containing water but do not allow to drain off water. eg clay layer.

Aquifuge:

Impermeable formation neither contains nor transmit water. Eg; Granite bed.

Porosity: Ratio of volume of voids to the total volume.

Permeability: Property of passing water.

Ground sources of water are follows:

1. Springs:

- ✓ A spring is the natural outflow of ground water appearing at the earth's surface as a current of stream of flowing water under the suitable geological conditions.
- ✓ Most favorable conditions occur in Nepal and may be suitable for w/s in village area in hilly region of Nepal.
- ✓ Springs are capable of supplying small quantity of water so it can't be used as a source of water to the big towns but a well developed or

combinations of the various springs can be used for water supply especially villages near hills or bases of hills.

- ✓ Quality is generally good and may contain sulphur in certain springs which discharge hot water which can be used only for taking dips for the cure of certain skin diseases.
- ✓ Low cost of construction because it may not need treatment plant.
- ✓ Springs may be classified into following two types:
 - a. Gravity springs
 - b. Non gravity Springs

a. Gravity spring:

It results from water flowing under hydrostatic pressure and they are of the following three types:

- i. Depression Spring
- ii. Surface Spring or contact Spring
- iii. Artesian Spring

i. Depression Spring:

These springs are formed due to the overflowing of the water table, where the ground surface intersects the water table as shown in the figure.



The flow from such spring is variable with the rise or fall of water table and hence in order to meet with such fluctuations a deep trench may be constructed near such spring.

The deeper is the trench, the greater is the certainty of continuous flow because the saturated ground above the elevation of the trench bottom will act as a storage reservoir to compensate for the fluctuations of the water table.

ii. Surface Spring or Contact Springs:

These are created by a permeable water bearing formation overlying a less permeable or impermeable formation that intersects the ground surface as shown in figure.

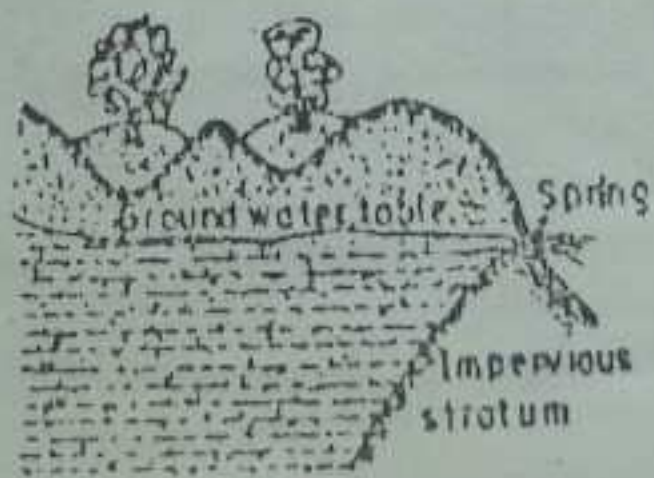

However in such springs, because of the relatively

Surface or Contact Spring

small amount of underground storage available above the elevation of the overflow crest, the flow from them is uncertain and likely to cease after a drought. Such springs can also be developed by the construction of a cutoff trench or a cutoff wall.

iii. Artesian Spring:

- These springs result from release of water under pressure from confined aquifers either at an outcrop of the aquifer or through an opening in the confining bed as shown in the figure.
- The amount of water available in an artesian spring may be large if the catchments area is large.
- The flow may be slightly increased by removal of obstructions from the mouth of the spring.

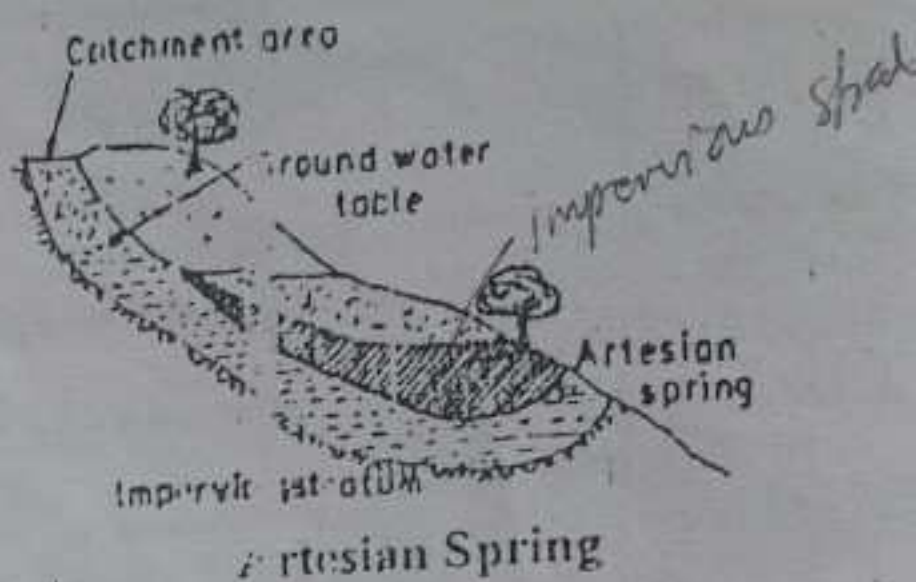

b. Non- Gravity Spring:

- Non-gravity springs include volcanic spring (associated with volcanic rocks) and fissure spring (results from fractures extending to the great depths in the earth's crust).
- These are also called hot springs and contain high minerals as well as sulphur also.

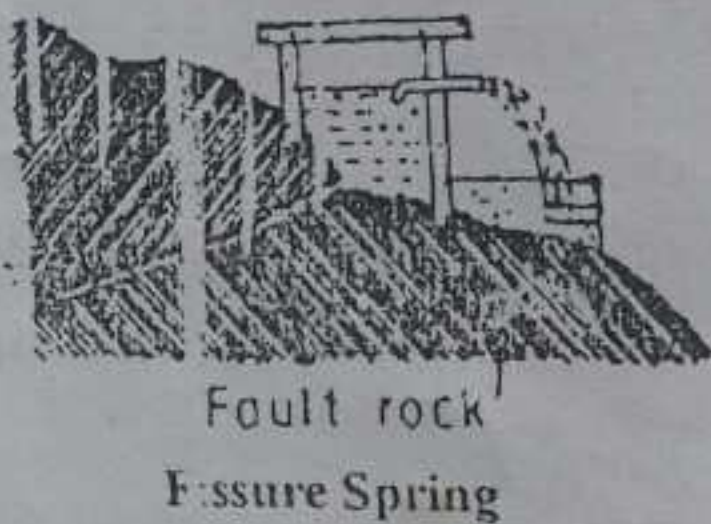

iv. Infiltration Galleries:

- ✓ A horizontal or nearly horizontal tunnel usually rectangular (arched also) in cross section and having permeable boundaries so that ground water can infiltrate into it. Hence it is also called horizontal well.
- ✓ It is generally located near a

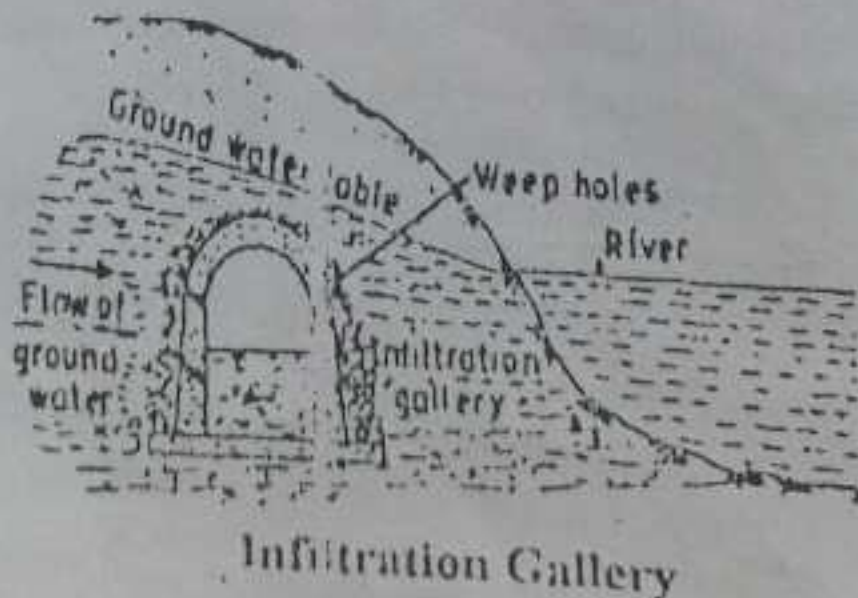

perennial recharge source such as the bank or under bed of a river and 3 to 10 meters below the ground. It is also used to collect ground water near marshy land or water bodies and stored in storage tank and then used for water supply.

- ✓ Quantity & quality depends upon the location and area of coverage.
- ✓ It is constructed by the cut and cover method and made up with dry brick masonry wall or porous concrete blocks with weep holes and R.C.C. slab roof or an arch roof. A manholes are provided at suitable points for inspection.
- ✓ The perforations are covered by the graded gravel to prevent the entry of fine particles in the gallery.
- ✓ Series of galleries may be laid in the proper slope and collected at certain reservoir then it can be used as the water supply after certain treatment.

3. Porous Pipe galleries

- ✓ When there is a large quantity of ground water existing over a wider area (i.e near marshy land or water bodies) it is cheap to collect ground water by laying porous pipe network under the ground and stored in storage tank and then used for water supply after some treatment as in infiltration galleries.
- ✓ In this case longitudinal and cross porous pipes are laid in certain slope to collect water in the collection well. To increase the intake capacity, these pipes should be surrounded with gravel and broken stone pieces.

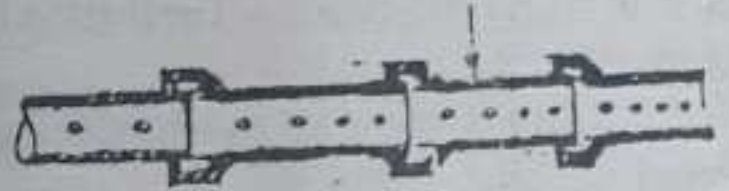
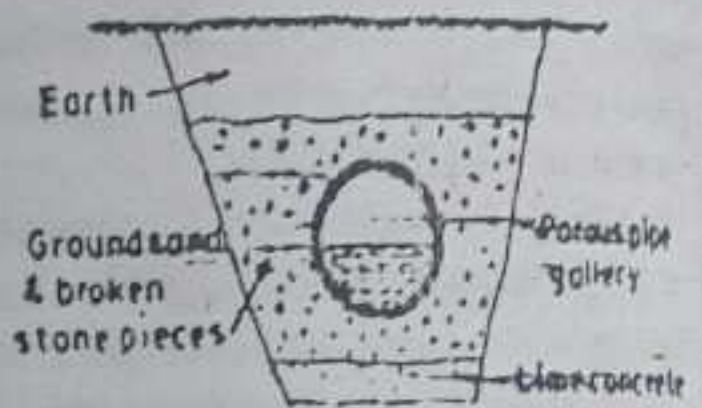

Porous Pipe Gallery (L-section)

4. Wells:

- ✓ A well is a hole or shaft, usually vertical and excavated in the ground for bringing groundwater to the surface.

✓ Wells are classified as follows:

a. Open or Dug or Draw or Percolation well:

- They are of large diameters (1 to 10 m), low yields and not very deep (2 to 20 m).
- These are constructed by digging hence also called dug wells.
- The walls may be of brick, stone masonry or precast rings and thickness varies from 0.5 to 0.75 m depending upon the depth of well.
- It is also further classified as:

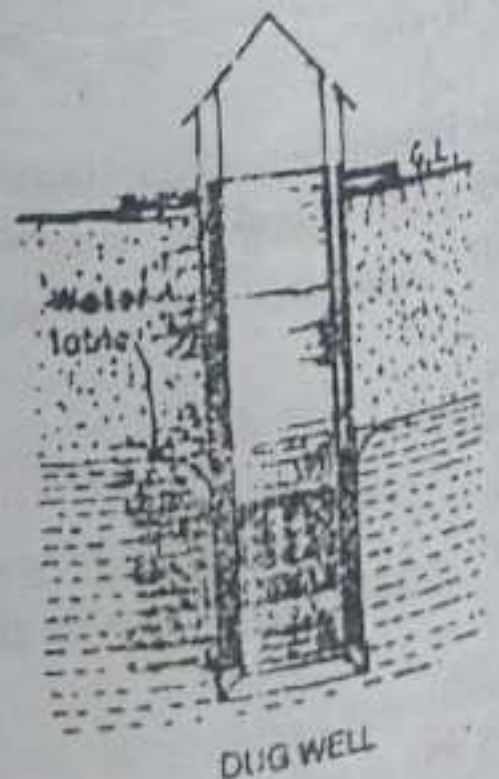

i. Shallow open well:

- It is the open well which rests on the top water bearing strata.
- It is cheap in construction and used in rural areas and small towns.
- Quantity of water is very smaller than deep wells because it yields water from the top water bearing strata only.
- This well should be disinfected frequently to avoid the risk of contamination.

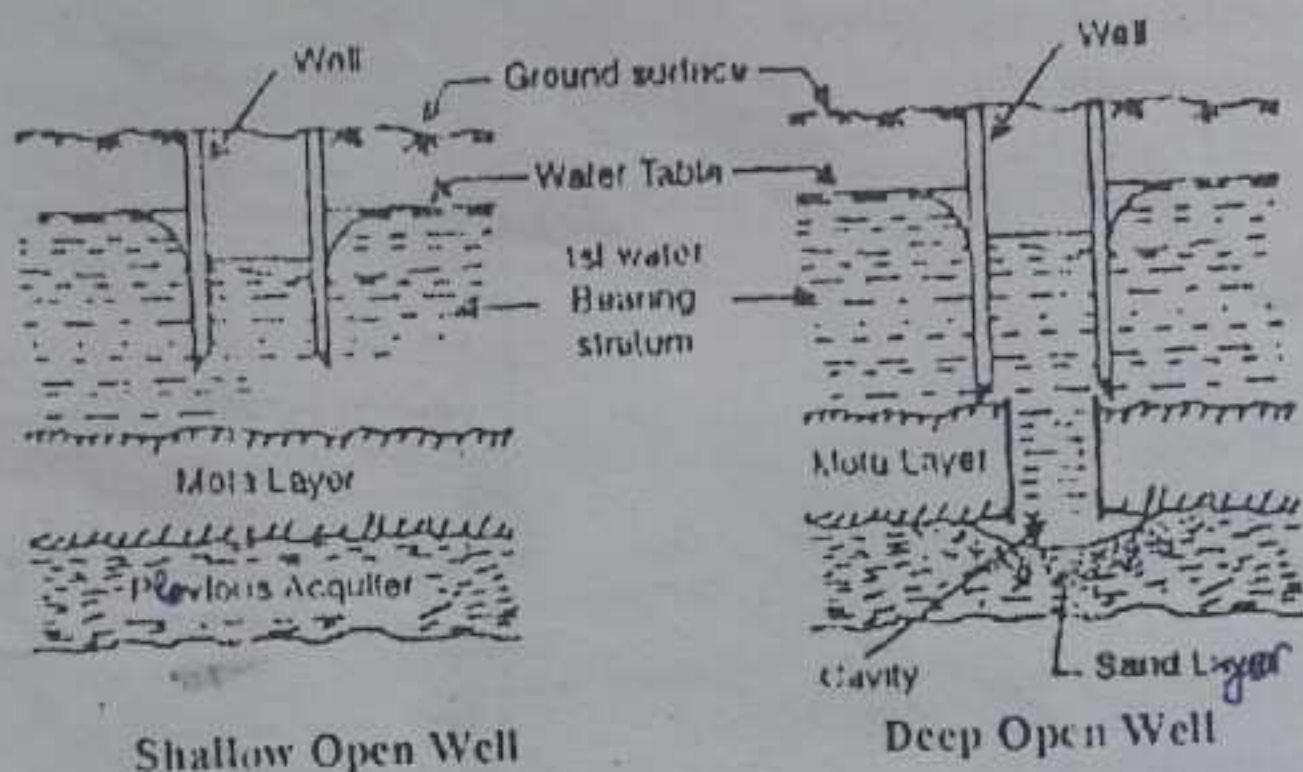

ii. Deep open well:

- It is the open well which rests on impervious strata and draws the supplies from the previous formation lying below the impervious strata through bore holes made in the impervious strata (generally called mota layer).
- The mota layer gives the structural support to the open well resting on it's surface.
- Quantity of water or yield is high because it draws water below the impervious strata.

b. Driven well or Percussion well:

- The shallow well constructed by driving a casing pipe of 2.5 cm to 15 cm in diameter and up to 12 m deep. The casing pipe is driven first in the ground by hammering or by water jet and the pipes are inserted.
- The lower part on of the pipe which is driven in the water bearing strata is perforated and the pointed bottom is called drive point or well point
- The perforated portion of pipe is covered with fine wire gauge to prevent passage of sand and soil particle.
- Discharge is very small and can be obtained using hand or electric pump and can be used for domestic purposes. eg Rower Pump used in the Kathmandu valley.

c. Tube well:

- It is the well made of small dia pipe installed after boring and inserted deep to trap water from different aquifers. In other words, A tube well is a long pipe sunk to the ground intercepting one or more water bearing strata. eg. In Terai regions of Nepal.
- As compared to open wells; the diameter of the tube wells are much less.
- Tube wells may be classified as shallow tube well (depth up to 30 m) and deep tube well (max. depth up to 600 m)
- Quality may be better but may have various impurities which should be treated and quantity is larger so it can be used as water supply.
- Tube wells may be further classified into the following:

i. Strainer type tube well:

- It is the mostly used tube well which has internal diameter 2.5 – 90 cm.
- It consists of a combination of strainer pipes in all water bearing strata and blind pipes in the hard strata only. The gravel is packed around the pipe which checks the entry of soil and soil particles.
- First boring is done by lowering a casing pipe of 5 to 10 cm larger than diameter of well pipe and the record of strata during boring is noted and blind and perforated pipes are joined as per the result then inserted into the casing.
- Gravel packing is done during removal of casing pipe.

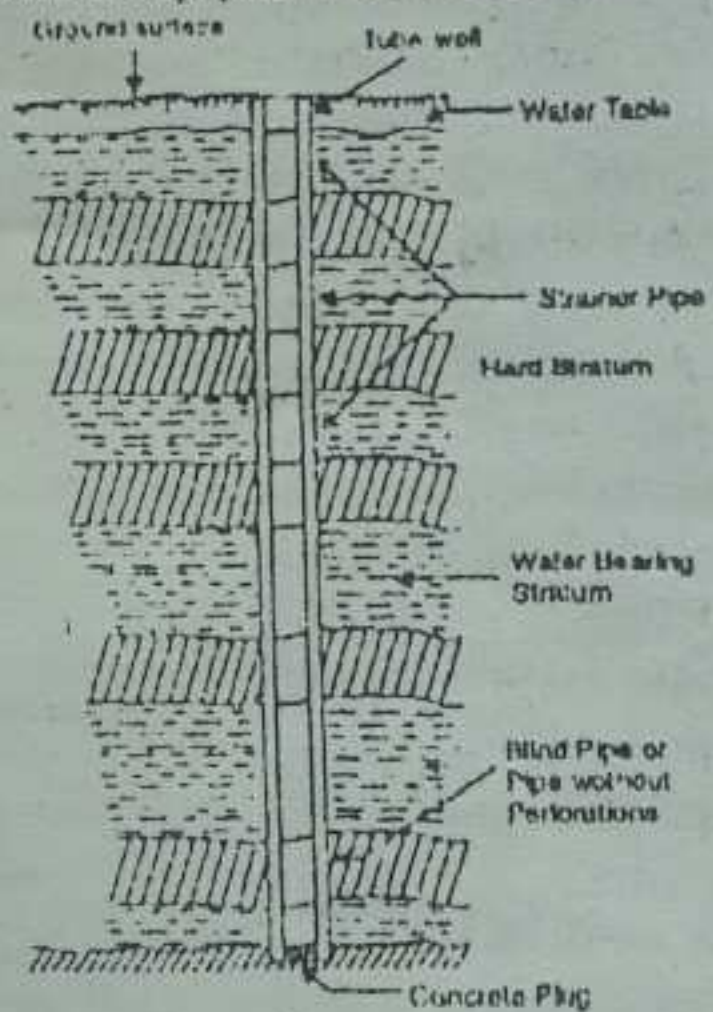

Section through a strainer type tube-well

ii. Cavity type tube well:

- It consists of blind pipe throughout its length and rests on hard stratum hence it can draw water from the lower stratum only.

- At beginning, just after construction, fine sand, silt come out along with the water and causes cavity at the bottom.
- When area of the cavity increases the flow area increases forming spherical part and increases the yield.

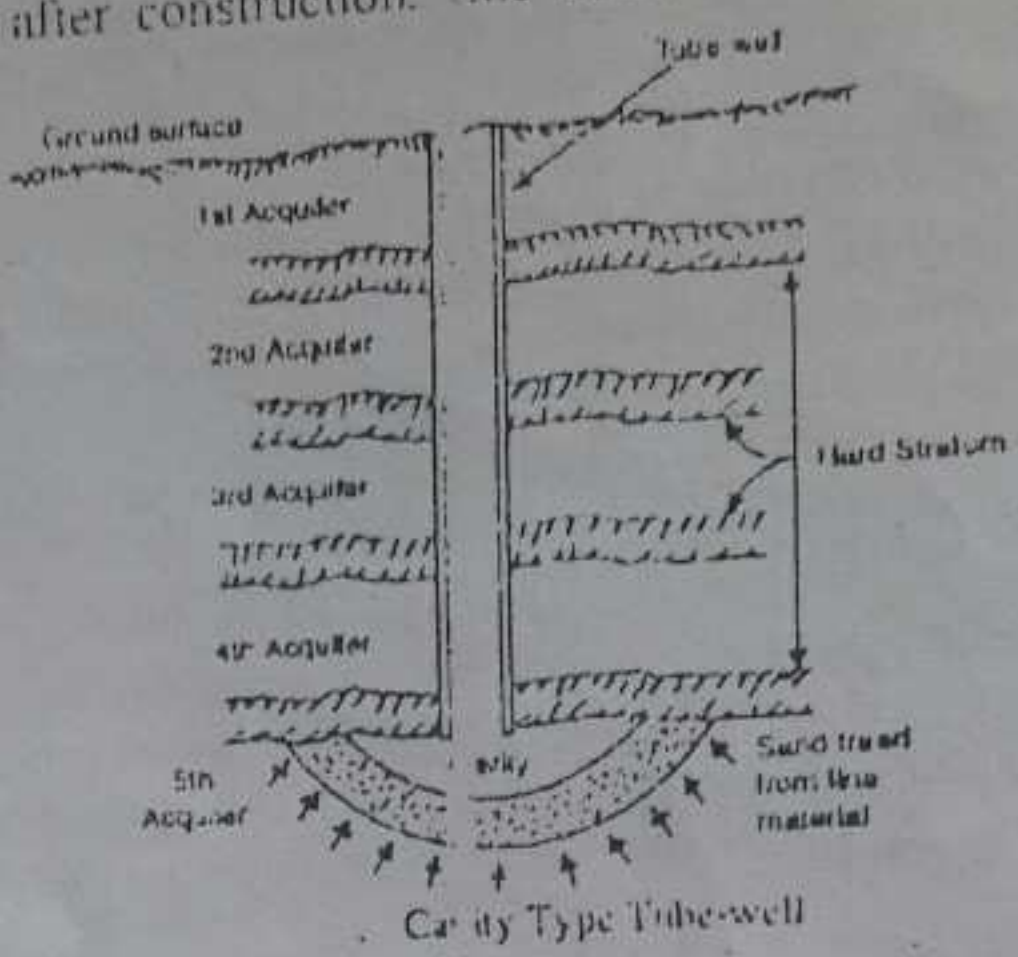

Cavity Type Tube-well

iii. Slotted type tube well:

- If sufficient no. of water bearing strata is not available to make strainer type tube well even up to 100 m, slotted type tube wells are used if at least 1 m water bearing strata is found.
- It consists of slotted wrought iron pipe passing through main water bearing strata. The slotted portion of pipe is surrounded by mixture of gravel and vagri called shrouding.
- Shrouding is filled between casing pipe and slotted pipe during withdrawing of casing.
- In the beginning the water is pumped at high rate which makes cavity, which is further filled by shrouding. Hence casing pipe of bigger diameter is required.

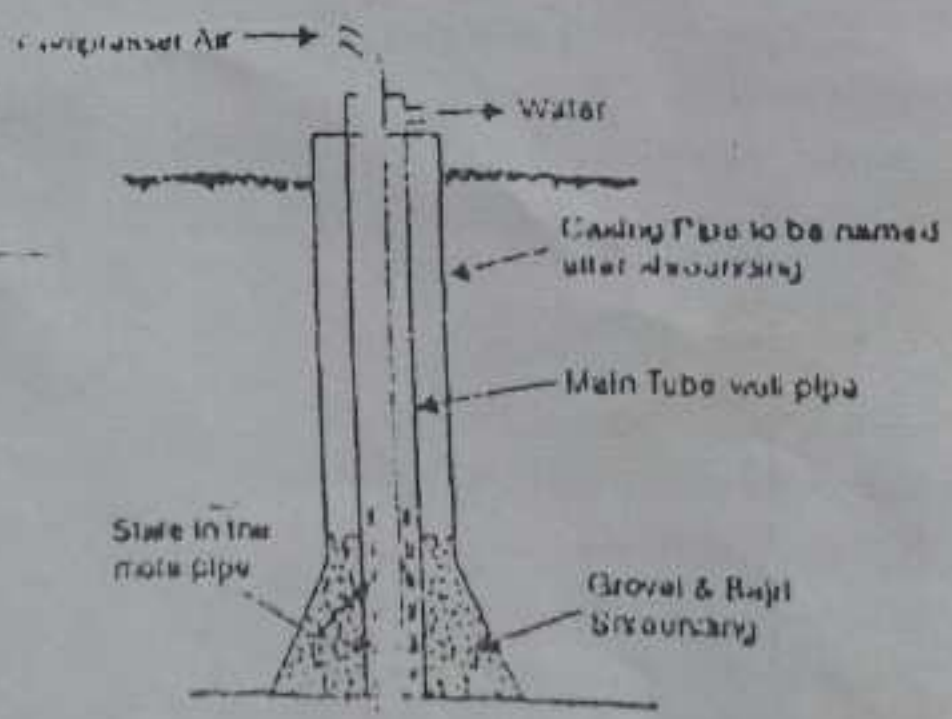

Slotted Type tube-well

iv. Perforated type tube well.

- It is used if water table is shallow and for obtaining water for short duration (temporarily) such as in construction sites.
- Pipes are drilled to make perforations and these holes are covered by jute ropes which act as strainer for preventing flow of sand particles.

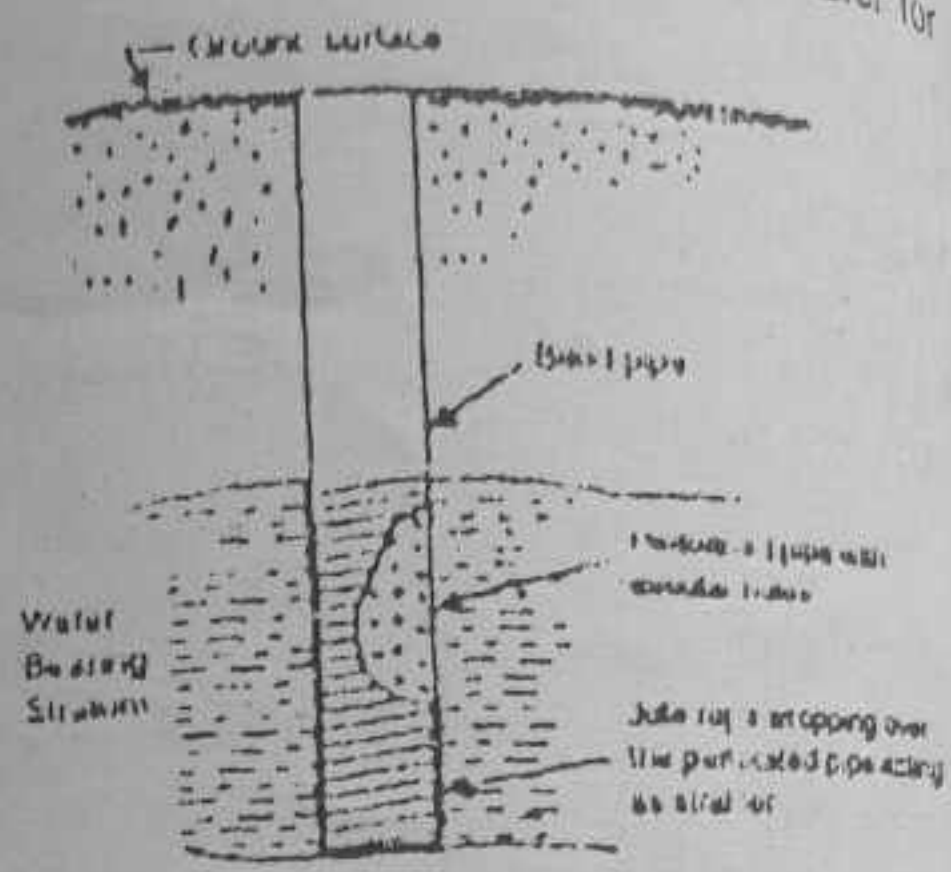

5. Artesian wells:

- ✓ It is the well from where water flows automatically under pressure. Mostly they are found in the valley portion of the hills where aquifers on the both sides are inclined towards valley.

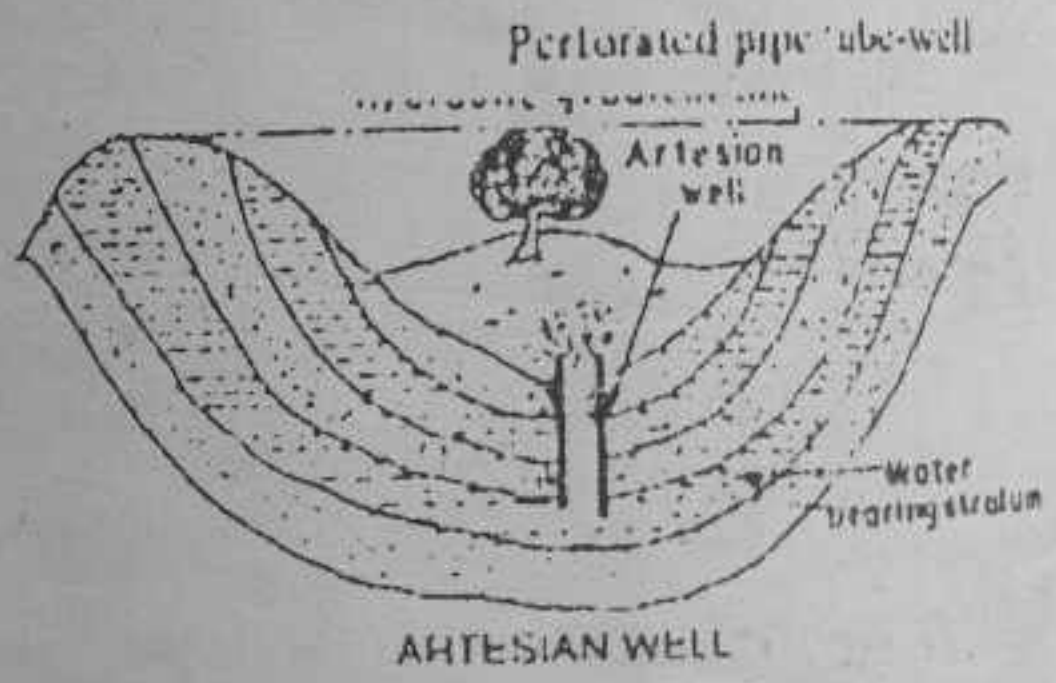

- ✓ The HGL (hydraulic gradient line) passes much above the mouth of well, which causes flow under pressure. The water flows out in the form of fountain up to a height of 2.5 m depending upon hydrostatic pressure.

- ✓ Some wells, water flows continuously throughout the year and can be stored in reservoir and taken for water supply.
- ✓ Quality may be good but sometimes it contains minerals and can be used after certain treatment.

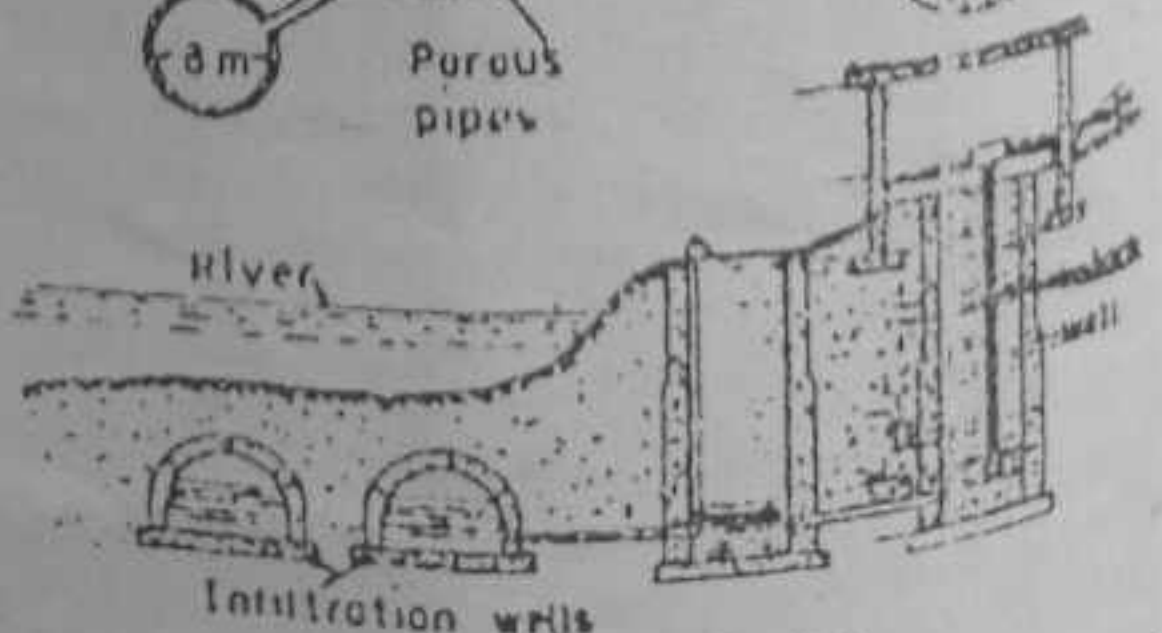
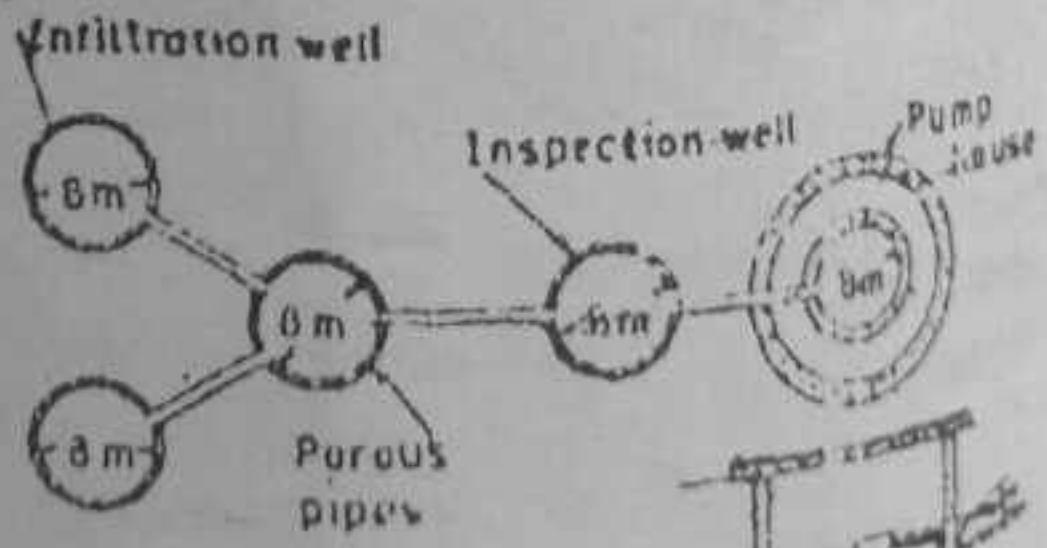

6. Infiltration Wells:

- ✓ Shallow wells constructed in series along the banks and sometimes under the bed of nallas & rivers to collect water seeping through the walls of the wells.
- ✓ These wells are constructed of brick masonry with open joints. For purpose of inspection, manhole is provided in the top cover of the well.
- ✓ The water infiltrates through the walls and bottom of these wells and has to pass through sand bed and gets purified to some extent.
- ✓ Various infiltration wells are connected by porous pipes and collected to the collecting sump well is called Jack from where it can be conveyed for water supply.
- ✓ Quality is better because the bed soil acts as a filter and lesser treatment may be required.

CAPACITY CALCULATION OF IMPOUNDED RESERVOIR

- ✓ If flow in the river or stream (inflow) \geq demand or draft (outflow) throughout year, no need of reservoir.
- ✓ If flow in the river or stream (inflow) $<$ demand or draft (outflow) during dry periods and maximum in other period the impounded reservoir should be required to reserve water during high runoff time to meet the demand during dry period.
- ✓ The capacity required for impounded reservoir can be determined from the any following two methods:

1. Mass curve Method:

- ✓ A mass inflow or cumulative runoff curve is the plot of the cumulative inflow in the reservoir with respect to time.
- ✓ A demand curve or outflow curve is a plot between cumulative demand or outflow with respect to time.
- ✓ This method is easy if rate of outflow is constant through out the time considered.

Procedure:

- a. Find cumulative runoff or inflow by adding runoff or inflow values for the period considered and plot the cumulative inflow or runoff versus time in scale.
- b. Find cumulative outflow or demand or draft by adding demand values and plot cumulative outflow versus time in scale. Only out flow per

unit time may be plotted if there is constant outflow throughout the time.

- c. Draw lines parallel to the demand curve tangential to the mass curve at the starting and end of the dry period.
- d. Required storage capacity of impounded reservoir is the maximum of the vertical intercepted ordinates between the two tangents drawn to a peak and trough consecutively.

2. Analytical Method:

This method is based on the assumption that the reservoir is full at the beginning of the dry period.

This method is easily calculated in tabular form and suitable when demand or outflow also varies with respect to time

Procedure:

- a. Denote (any monthly) inflow or runoff as 'I' and monthly draft or demand as 'O'.
- b. Determine the deficiency 'D' or surplus 'S' by $(I - O)$.
Deficiency (D) occurs if $(I - O)$ is -ve and Surplus if $(I - O)$ is +ve.
- c. Calculate the cumulative deficiency i. e. $\sum D$, which is the required storage capacity of the impounded reservoir.

d. If $\sum D > \sum S$, the project is not feasible.

Example 2.1: The yield of water from a catchment area during each successive month is given below.

Month	Jan	Feb	Mar	Apr	May	Jun	Jul	Aug	Sep	Oct	Nov	Dec
Inflow (Million m ³)	1.4	2.1	2.8	8.4	11.9	11.9	7.7	2.8	2.52	2.24	1.96	1.68

Determine the minimum capacity of impounding reservoir required to allow the above volume of water to be drawn off at a uniform rate assuming that there is no loss of water over the spillway. Use (i) analytical method (ii) Mass curve method

Solution:

Total inflow = $\sum \text{Inflows} = 57.4 \times 10^6 \text{ m}^3$

Here there is no loss of water over the spillway, then

$$\text{Average monthly demand} = \frac{57.4 \times 10^6}{12} = 4.78 \times 10^6 \text{ m}^3$$

1 million =

Water Supply Engineering

(a) Analytical Method

Cum. demand	Month	Inflow (I) [$\times 10^6 \text{ m}^3$]	Cumulative Inflow [$\times 10^6 \text{ m}^3$]	Demand (O) [$\times 10^6 \text{ m}^3$]	Deficit (O - I) [$\times 10^6 \text{ m}^3$]	Surplus (I - O) [$\times 10^6 \text{ m}^3$]	Remarks
4.78	Jan	1.4	1.4	4.78	3.38	-	Note: Cumulative inflow column is only useful for mass curve method and not necessary here
9.56	Feb	2.1	3.5	4.78	2.68	-	
14.34	Mar	2.8	6.3	4.78	1.98	-	
19.12	Apr	8.4	14.7	4.78	-	3.62	
23.9	May	11.9	26.6	4.78	-	7.12	
28.68	Jun	11.9	38.5	4.78	-	7.12	
33.46	Jul	7.7	46.2	4.78	-	2.92	
38.24	Aug	2.8	49	4.78	1.98	-	
43.02	Sep	2.52	51.52	4.78	1.26	-	
47.8	Oct	2.24	53.76	4.78	2.54	-	
52.58	Nov	1.96	55.72	4.78	3.82	-	
57.36	Dec	1.68	57.4	4.78	3.1	-	
Total deficit					20.74	20.78	

So, Minimum storage required = Total deficit = $20.74 \times 10^6 \text{ m}^3$

(b) Mass Curve Method:

The cumulative inflow versus month is plotted in scale in the graph.

The reservoir capacity as per graph is equals to the maximum of the vertical intercepted ordinates between the two tangents drawn to a peak and trough consecutively

$$= (S_1 - S_2) + (S_3 - S_4) = \{(14.35 - 6.30) + (46.20 - 33.50)\} \times 10^6 \text{ m}^3$$

$$= 20.75 \times 10^6 \text{ m}^3$$

$$S_A + S_B$$

Minimum Capacity of Imp. reservoirs (total deficit)

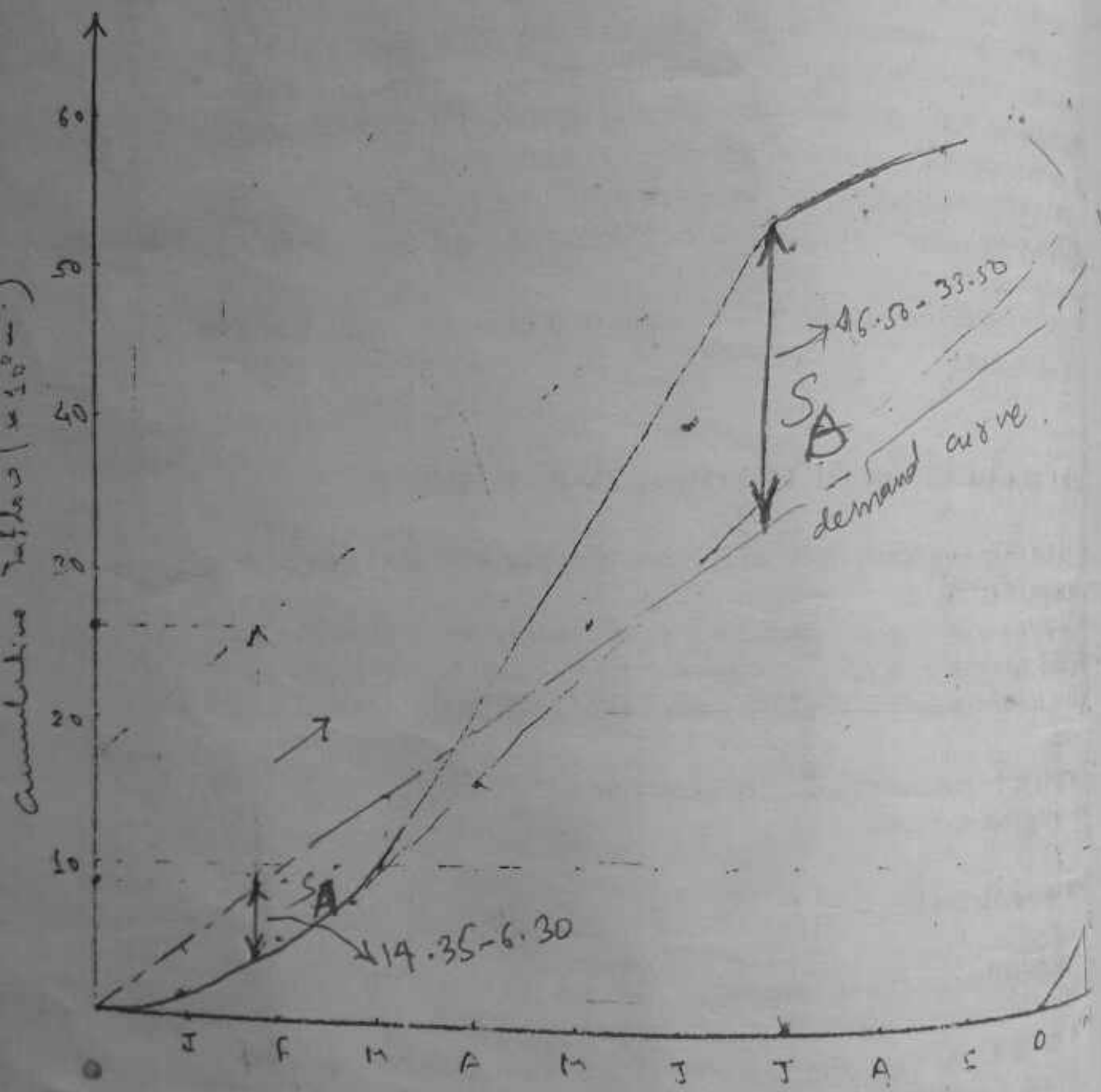

CHAPTER 3. QUANTITY OF WATER

3.1 INTRODUCTION

- Before designing an / w/s project, it is required to:
 - (a) Determine demand
 - (b) Fixation of design period and
 - (c) Population forecast up to the end of the design period

3.2 DEMAND & THEIR TYPES

- Determination of demand is very necessary before designing a w/s project. Its unit is lpcd (liters per capita per day).
- Demand is higher in developed countries & less in developing countries.
- After calculating total demand, the source or combination of the sources is searched to achieve full demand.
- Total demand for w/s is the sum of the following types of demands.

a. Domestic demand:

✓ Demand of water for home use including drinking, cooking, bathing, washing, and house sanitation.

✓ Depends upon the habit, social status, climatic condition, living standard etc.

✓ As per IS: 1172-1993, 135 and 200 lpcd for small and large towns respectively in India.

✓ Other developed country it is 250 - 350 lpcd due to the use of air coolers, air conditioners & others.

✓ WHO standard is min 45 lpcd and 100 - 160 lpcd for rural and urban areas respectively as in the countries like Nepal.

✓ In design practice in Nepal,

Rural area with public tap (no private connection) = 25 - 45 lpcd (generally 45 lpcd)

Semi urban (public & private connection with out sanitation) = 65 lpcd.

Urban (public & private connection with sanitation) = 100 -135 lpcd (generally 112 lpcd)

Average Domestic Demand for Asian ^{cities} countries = 135 lpcd

b. Livestock Demand: ^{cities} of developed countries = 350 lpcd

✓ The quantity of water required for domestic animals and livestock (birds) is called live stock demand.

✓ Generally considered in rural w/s but in Nepal it is also considered in urban w/s also.

✓ In practice, up to 20% of domestic demand may be used.

a.	Drinking	5
b.	Cooking	5
c.	Bathing	55
d.	Cloths Washing	20
e.	Utensils washing	10
f.	House Washing	10
g.	Flushing Latrines	30
Total		135 lpcd

Live stocks & domestic animals demand (l/animal/day)				
In India		In Nepal		
		Department of w/s & sewerage guidelines		UNICEF Guidelines
a. Cows/bullalo	65-25	a. Big animals (cow/bullalo/horses)	45	a. Horses 35
b. Dogs	1-20	b. Medium animals (Dog, lamb, goat, rabbit etc.)	20	b. Cattle, Buffalo 40
c. Chickens	6-10	c. Smaller animals (Birds, chickens, duck etc.)	20/100	c. Pigs, sheep, goats 10-15
d. Goats, sheep	1-60			d. Chickens 15/100
e. Horses	45-50			

c. Commercial & Institutional demand:

✓ Includes the demand for office building, warehouse, stores, hotels, schools, hospitals, theaters, clubs etc.

✓ For commercial & institutional purpose 45 lpcd can be taken
 Commercial & Institutional Demand As per IS: 1172-1993 (Indian Standard Code of Basic Requirements for Water Supply, Drainage & sanitation)

S. No.	Types of Building	Consumption (lpcd)
1	a. Factories with bathrooms	45
	b. Factories without bathrooms	30
2	a. Hospitals < 100 beds (per bed)	340
	b. Hospitals > 100 beds (per bed)	450
3	Nurse home & quarters	135
4	Hostels	135
5	Offices	45
6	Restaurants (per seat)	70
7	Hotel (per bed)	180
8	Cinema concert halls & theaters (per Seat)	15
9	Schools	
	a. Day scholars	45
	b. Boarding schools	135

Commercial & Institutional Demand Used in Nepal

Institution	Demand	
	Urban area	Rural area
a. Hospitals/Health Posts/Clinics		
i. with Bed	500 lit/bed/day	325 - 500 lit/bed/day
ii. without bed	2500 lit/day	1600 - 2500 lit/hospital/day
b. Schools		
i. boarders	65 - 135 lpcd (65 generally)	42 - 60 lpcd
ii. day scholar	10 - 45 lpcd (10 generally)	6.5 - 10 lpcd
c. Hotels		
i. with bed	200 lit/bed/day	200 lit/bed/day
ii. with out bed	500 - 1000 lit/day	500 - 1000 lit/day
d. Restaurants/Tea stall	500 - 1000 lit/day	200 - 500 lit/day
e. Offices		
i. unclassified	500 - 1000 lit/day	325 - 1000 lit/office/day
ii. Resident	65 lpcd	65 lpcd
iii. Non resident	10 lpcd	10 lpcd

Water Supply Engineering

d. Industrial Demand:

- ✓ There is no relationship between industrial demand and population. Separate calculation for industrial demand is done because this demand depends upon the type of the industry.
- ✓ Normally 20 - 25% of the total demand is taken for industrial demand.

e. Demand for public places or municipal demand:

- ✓ Includes washing & sprinkling on road, cleaning sewers, watering public parks, gardens etc.
- ✓ Generally 5 - 10% of the total demand for a city is taken.
- ✓ Public parks 1.4 l/m²/day, street washing 1 - 1.5 l/m²/day, sewer cleaning 4.5 l/m²/day, garden & sports ground 3.5 l/m²/d

f. Fire Demand:

- ✓ During outbreak of fire, the water used for fire fighting is called fire demand. This demand is not fixed so it is difficult to calculate this demand.
- ✓ Fire hydrants of 15 - 20 cm diameter are provided on water mains 100 - 150 m apart to extract through water for fire fighting.
- ✓ To calculate this demand, different formulas are used but suitable for specific condition and location so it can not be directly used for Nepalese condition.

4. i. National Board of Fire Underwriter's formula

$$Q = 46.37 \sqrt{P} (1 - 0.01 \sqrt{P})$$

Where, Q = quantity of water in l/min and P = Population in thousands

- It is suitable when population is < 2 lacks. For population > 2 lacks, provide 54600 lit/min with extra provision of 9100 - 36400 lit/min for second fire.

3. ii. J.R. Freeman's formula

$$Q = 1136 \left(\frac{P}{5} + 10 \right) \quad Q = 1136.5 \left(\frac{P}{5} + 10 \right)$$

Where Q = quantity of water in l/min and P = Population in thousands

1. iii. Kulechling's formula

$$Q = 3182 \sqrt{P}$$

Where Q = quantity of water in l/min and P = Population in thousands

- National Board of Fire Underwriter's formula and J.R. Freeman formula gives high values so this Kulechling's formula is suitable for country like ours.

2. iv. *Buston's formula*

$Q = 5663\sqrt{P}$ Where Q = quantity of water in l/min and P = Population in thousands

v. *Indian water supply manual (1976) formula:*

$$Q = 100\sqrt{P}$$

Where Q = quantity of water in m^3/day and P = Population in thousands

g. *Compensate losses demand:*

- ✓ Includes losses due to defective pipe joints, cracked & broken pipes, faulty valves & fittings, unauthorized connection (theft), allowance for keeping tap open etc.
- ✓ Generally 15% of the total demand for a city and zero for rural area is taken.
- ✓ 50% loss in Kathmandu Valley (Metered supply loss is 30% and in addition to un-metered supply it is rise up to 50%)

Per Capita Demand or rate of demand:

It is define as the total annual average daily consumption including all demands of water for a person. Mathematically,

$$q = \frac{Q}{P \times 365} \text{ lpcd, Where,}$$

Q = Total quantity of water required (summations for all demand) for a area for a year in liters and

P = Population of a town (found after forecasting) at the end of the design period

3.3 FACTORS AFFECTING DEMAND

- Variations in the rate of demand of a community occur due to several factors which must be carefully analyzed before fixing the water demand for that community.
- Some factors affecting demand are as follows:
 - a. *Size & type of community:*
Bigger size, higher the demand due to lot of public places of utility and recreation such as parks, lawn, ponds fountain etc.
 - b. *Living standard of people:*
Living standard high, higher is the demand.
 - c. *Climatic condition*
Hot climate, higher the demand.
 - d. *Quality of water:*
Good quality, higher the demand.



e. *Pressure in the supply:*

The energy required to move water through pipe is called pressure energy measured in kg/cm^2 or m if expressed in terms of head. Higher the pressure, loss is more and higher is the demand.

f. *Sanitation system:*

Sewage (waste product from domestic, commercial, or industrial uses and operation) may be disposed either by *sewerage system* or by *in-situ (on-site) system* which is called system of sanitation. In sewerage system sewage is carried away and in in-situ system sewage is not carried but disposed on site. Good sanitation system (water carriage sewerage system) makes, higher the demand because more water is needed to carry sewage.

g. *Metering:*

Use of *water meter* (an instrument kept on the way of incoming flow to record the quantity of water used by the user), lesser the demand.

h. *System of supply:* $\begin{matrix} \rightarrow \text{open} \\ \rightarrow \text{closed} \end{matrix}$

Demand is lesser in intermittent and higher for continuous. (A conflicting point)

* i. *Water rates: Revenue collection:*

The rate may lower for minimum units and higher to other limiting units. Higher the rate, lesser is the demand.

j. *Age of the community:*

In newly city the demand is higher due to construction, planting trees etc.

k. *Lawn (grassy ground) sprinkling:* If done higher the demand

l. *Availability of local sources:* If available, lower the demand

m. *Education and awareness of the people:*

Education and awareness changes the behavior of people in health care than water demand which led to use more water.

n. *Other socio-economic factors:*

i. *Public versus private tap stand:* Public tap, lower the demand.

ii. *Affluent (wealthy) versus subsistence (survival):* Rich family, higher the demand.

iii. *Habits of people:* Frequency and bathing habits of people in the river, stream, and pond also affect the demand.

iv. *Distance to tap stand:* Nearer demand is high. As per UNICEF guidelines tap stand is located at a distance not greater than 200m horizontal and 50 m vertical.

v. *Urban versus rural:* lower demand in rural area due to sanitation system, habit, living standard etc.

VARIATION IN THE DEMAND

- Fluctuation of water demand with respect to time is called variation of demand.

- The per capita demand of water is obtained by dividing the total quantity of water supplied during year by the no of days in the year and the no of person served and called annual average daily consumption per person.
- The annual average daily consumption is not sufficient in design because demand varies year to year, season to season, month to month, day to day and even for hour to hour.
- Maximum demand: at all these variations are expressed in terms of percentage of average annual daily consumption (AADC) so that it is very useful in designing various components.

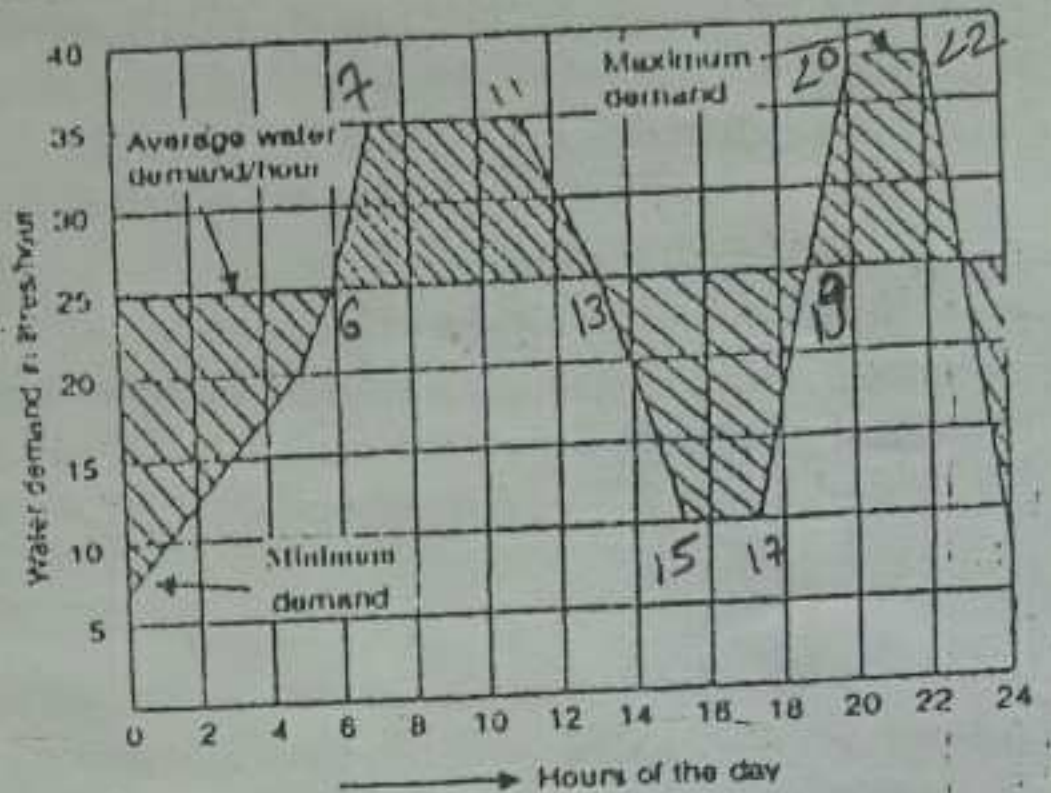

Hourly variation of the rate of consumption.

- a. **Seasonal variation:**
 - ✓ Demand varies with season to season. In summer, higher the demand because more bathing, cooling, lawn watering & street sprinkling & lesser in winter.
- b. **Daily variation:**
 - ✓ Demand varies with day to day also and depends upon the habit of people, climatic conditions (rainy day high and in dry day high) and the character of the city (industrial, commercial or residential)
 - ✓ Demand is more in the feasts and festivals.
- c. **Hourly variation:**
 - ✓ Demand also varies even hour to hour. Maximum in morning & evening, in holidays due to washing, cleaning, bathing etc.
 - ✓ Peak demand (demand when maximum supply is required) on 6AM to 10AM & 4PM to 8PM and minimum on 12PM 4AM etc.
- Any maximum demand at variation is expressed in terms of % of annual average daily consumption (AADC).
 - AADC = (The total quantity of water supplied during the year / Population / 365)
 - ✓ Maximum seasonal demand = 130% of AADC = 1.3 × AADC
 - ✓ Maximum daily demand = 180% of AADC = 1.8 × AADC
 - ✓ Maximum monthly demand = 140% of AADC = 1.4 × AADC
 - ✓ Maximum hourly demand = 150% of AADC = 1.5 × AADC
- Seasonal, daily and hourly variation is very important in the design.

Water Supply Engineering

Peak demand and peak factor:

Peak demand is maximum hourly demand at the maximum day of maximum season so it is obtained from by:

$$\text{Peak demand} = 1.3 \times 1.8 \times 1.5 \text{ of AADC} = 3.5 \times \text{AADC}$$

Here, the multiplying factor 3.5 is called *Peak factor*. In Nepal it is taken as 2-4 (3 generally)

Absolute maximum hourly demand: It is the maximum hourly demand on the maximum day at maximum month of maximum season.

Design should match for each demand. For example, the filters and pumps must design 1.5 of AADC and distribution main should be designed for 2.7 of AADC.

3.5 DESIGN PERIOD

Survey year:

Year in which survey is carried out

Base Period:

It is the period of survey, design & construction. Design period is considered after base year. Base period is generally taken as 2-3 years. In Nepal it is taken as 2 years.

Base year:

Year in which implementation is done

$$\text{Base Year} = \text{Survey year} + \text{Base period}$$

Design Period:

Any water supply project is planned to meet the present requirements of community as well as the requirement for a reasonable future period (up to service year) taken in design is called as design period. It should be neither long (financial overburden) nor short (uneconomical). It is taken as 22 to 30 years and even for 50 years if dam storage is done. In Nepal, this period is generally taken as 15-20 years in rural areas and 25-30 (generally 25) years in urban areas.

Service year: Year up to which the scheme can fulfill demand

$$\text{Service Year} = \text{Survey year} + \text{Base period} + \text{design period}$$

Survey Year	Base year	Service year (Designed year)
2003	2005	2020
Base Period (2 Yrs)		Design period (15 yrs)

Selection basis of design period:

• Design period shall be fixed after considering the following:

a. Fund available: More fund higher the design period

b. Life of the pipes and constructional materials: Design period should not be greater than the life of pipes and constructional materials used. As far as possible it is nearer to the life of pipes and constructional materials

- c. Rate of interest of loan: If more the rate of interest, less it will be the design period.
- d. Anticipated expansion rate of the town: If growth rate (r) is high, design period is less. In Nepal:
 If $r \geq 2$, design period is 15 years and if $r < 2$, design period is 20 years
 If $r < 1\%$, r is taken as 1% .

3.6 POPULATION FORECAST:

- After fixing the design period it is necessary to forecast or estimate the future population for the end of service year because it fluctuates due to the death, births and migrations.
- Normally population increases and the increment of the city population depends upon various factors such as living standard, industrial potential, infrastructure development, opportunities, climates etc.
- The information of population of a city or village can be obtained from census of HMG (Bureau of Statistics or other authority).
- The census is usually conducted by government at an interval of 10 years called decennial census. Sometimes information on population is obtained by conducting surveys.
- Various methods are available for forecasting population at the end of design period on the basis of those census or survey data but the designer should be able to do exercises on them and judge the suitable method for a particular locality.
- **Factors Affecting Population Growth:**
 - i. *Economic factors:* Opportunity of economic activities
 - ii. *Development Program:* National project, establishment of new industries, mine etc
 - iii. *Social facilities:* Educational, health, recreational, security etc.
 - iv. *Communication & information:* Transportation, communication, information etc
 - v. *Tourism:* Attractive places for the tourist or tourists: industry, religious place, natural scenery etc.
 - vi. *Community Life:* Living habits, social costume (ठोठरिठ) and religious community, types of classes, educational level etc
 - vii. *Unforeseen factors:* Earthquake, flood, epidemics, war, migration due to war & refugees, frequent famines (३०-११-१) etc
- **Methods of Population Forecasting**

1. Arithmetic Increase Method	2. Geometrical Increase Method
3. Incremental Increase Method	4. Decreasing rate Method
5. Logistic Curve method.	6. Simple Graphical Method
7. Comparative Graphical Method	8. Master Plan Method
9. Apportionment Method	

Imp (1-5)

1. Arithmetical increase method: follow book.

- ✓ Simple method and analogous to simple interest.
- ✓ Suitable for larger & old cities, practically reached their maximum development.
- ✓ This method is based on the assumption that average rate of increase in population per time unit 'e' is constant.

$\frac{dp}{dt} = e$, a constant, then,

$$P_1 = P_0 + e = P_0 + 1e,$$

$$P_2 = P_1 + e = P_0 + 1e + e = P_0 + 2e,$$

$$P_3 = P_2 + e = P_0 + 2e + e = P_0 + 3e$$

Generalizing,

$$P_n = P_0 + ne$$

Here,

P_1 = No. of population at time t_1

P_2 = No. of population at time t_2

P_n = No. of population at n^{th} time unit

P_0 = No. of present (last known) population

n = No. of time units (present to future)

e = Average (arithmetic mean) of increase in population (No. / time unit)

r = Average of the % increase (%/time unit)

i = Average incremental increase (Nos / time unit)

Note: Time unit may be year or decade

2. Geometrical increase method:

- ✓ Analogous to compound interest.
- ✓ Based on assumption that % increase in the population per time unit remains constant for each time unit.
- ✓ It is also known as uniform growth method.
- ✓ Suitable when the city is young and rapidly increasing. This is commonly used method in Nepal.
- ✓ In this method average % of growth 'r' of last few time units is determined and forecast is done on the basis that % increase per unit time is same. Then,

$$P_1 = P_0 + r\% \text{ of } P_0 = P_0 \left(1 + \frac{r}{100}\right) = P_0 \left(1 + \frac{r}{100}\right)^1,$$

$$P_2 = P_1 + r\% \text{ of } P_1 = P_1 \left(1 + \frac{r}{100}\right) = P_0 \left(1 + \frac{r}{100}\right) \left(1 + \frac{r}{100}\right) = P_0 \left(1 + \frac{r}{100}\right)^2,$$

$$P_3 = P_2 + r\% \text{ of } P_2 = P_2 \left(1 + \frac{r}{100}\right) = P_0 \left(1 + \frac{r}{100}\right)^2 \left(1 + \frac{r}{100}\right) = P_0 \left(1 + \frac{r}{100}\right)^3$$

Generalizing,

$$P_n = P_0 \left(1 + \frac{r}{100}\right)^n$$

3. Incremental Increase Method:

- ✓ It is an improvement over above Arithmetical & Geometrical method and seems to be combination of them.
- ✓ From previous census data the actual increase, then the increment in increase (called incremental increase) in each of those time unit and an average of incremental increase per time unit 'i' is calculated.
- ✓ The population in the next time unit is calculated by adding the present population the average increase 'e' plus the net incremental increase for that time unit.

✓ The process is repeated for second time units and so on.

✓ Here, growth rate seems to be varying. Then,

$$P_1 = P_0 + (c + i) = P_0 + c + i = P_0 + c + \frac{(1+1)}{2}i$$

$$P_2 = P_1 + (c + 2i) = (P_0 + c + i) + (c + 2i) = P_0 + 2c + 3i = P_0 + 2c + 2 \cdot \frac{(2+1)}{2}i$$

$$P_3 = P_2 + (c + 3i) = (P_0 + 2c + 3i) + (c + 3i) = P_0 + 3c + 6i = P_0 + 3c + 3 \cdot \frac{(3+1)}{2}i$$

Generalizing,

$$P_n = P_0 + nc + n \cdot \frac{(n+1)}{2}i$$

4. Decreasing rate of growth or changing rate of increase Method:

✓ If we consider complete growth of a very old city, we can see that the early growth takes place at an increasing rate but later the growth is at a decreasing rate. Hence this method is similar to the geometrical increase method except that instead of constant value of % increase in population per time unit, the increase in population per unit time is adopted for each future time units.

✓ This method is useful for the old established cities, where population is approaching to saturation limit and rate of growth is showing downward trend.

✓ In this method the average decrease in % increment per time unit 'd' is calculated after calculating increase and then % increase in population.

✓ The following formulae may be used for future population at nth time unit

(a) Find net % increase in nth time unit by,

$$I_n = I_{n-1} + d \text{ or } I_n = I_0 + nd$$

(b) Then, population at nth time unit is,

$$P_n = P_{n-1} \left(1 + \frac{I_n}{100}\right)$$

Generalizing,

$$P_n = P_0 \prod_{j=1}^n \left[1 + \frac{I_0 + jd}{100}\right] = P_0 \prod_{j=1}^n \left[1 + \frac{I_0 + jd}{100}\right]$$

Here,

I_0 = % increase in population in last known year (%/ time unit)

I_{n-1} = % increase in population in (n-1)th time unit

P_{n-1} = No of population just before nth time

d = Average decrease in % increment (%/ time unit)

Note: Time unit may be year or decade

5. Logistic Curve method:

✓ Under normal conditions the rate of increase in population with respect to time does not remain constant as assumed in arithmetical method but varies and grow up as per S-shaped curve (a plot of population versus time) called logistic curve. (See fig 3.1)

✓ In the curve, AB portion represents early growth at increasing rate (geometric or log growth); BC represents decreasing rate as the saturation value (P_s) is reached and CD follows an arithmetic increase.

Water Supply Engineering

- ✓ The future population depends upon the position of point on the growth curve at a given time.
- ✓ P.F. Verhulst gave the mathematical solution for the logistic curve after his research and according to him the entire curve (A) can be represented by following equation:

$$\log_e \left(\frac{P_s - P}{P} \right) = \log_e \left(\frac{P_s - P_0}{P_0} \right) e^{-KP_s t}$$

Where,

- P_0 = Population at the start point 'A' of the curve
- P_s = Saturation Population at the end point 'E' of the curve
- P = Population at any time 't' from origin 'A'
- K = A constant

$$\text{or, } \log_e \left[\left(\frac{P_s - P}{P} \right) \left(\frac{P_0}{P_s - P_0} \right) \right] = -KP_s t$$

$$\left[\log_e P_s - \log_e P - \log_e \left(\frac{P_0}{P_s - P_0} \right) \right]$$

$$\text{or, } \frac{P_s - P}{P} = \left(\frac{P_s - P_0}{P_0} \right) \log_e^{-1} (-KP_s t) \text{ or, } \frac{P_s}{P} = 1 + \left(\frac{P_s - P_0}{P_0} \right) e^{-KP_s t}$$

$$\therefore P = \frac{P_s}{1 + \left(\frac{P_s - P_0}{P_0} \right) \log_e^{-1} (-KP_s t)} \quad \text{Putting, } \left(\frac{P_s - P_0}{P_0} \right) = m, \text{ and } (-KP_s) = n,$$

the required equation of a logistic curve formula reduces to,

$$\boxed{P = \frac{P_s}{1 + m \log_e^{-1} (n t)}}$$

McLean further suggested that if only three pairs of characteristic values P_0 , P_1 and P_2 at time $t = t_0 = 0$, t_1 and $t_2 = 2t_1$ extending over useful range of census populations, are chosen, the saturation value P_s and the constants m and n can be evaluated as follows:

$$P_s = \frac{2P_0 P_1 P_2 - P_1^2 (P_0 + P_2)}{P_0 P_2 - P_1^2}, \quad m = \left(\frac{P_s - P_0}{P_0} \right) \text{ and } n = \left(\frac{1}{t_1} \right) \log_e \left(\frac{P_0 (P_s - P_1)}{P_1 (P_s - P_0)} \right)$$

Alternatively, the equation can be expressed as:

$$\boxed{P = \frac{P_s}{1 + e^{a + bt}}} \quad \text{Where,}$$

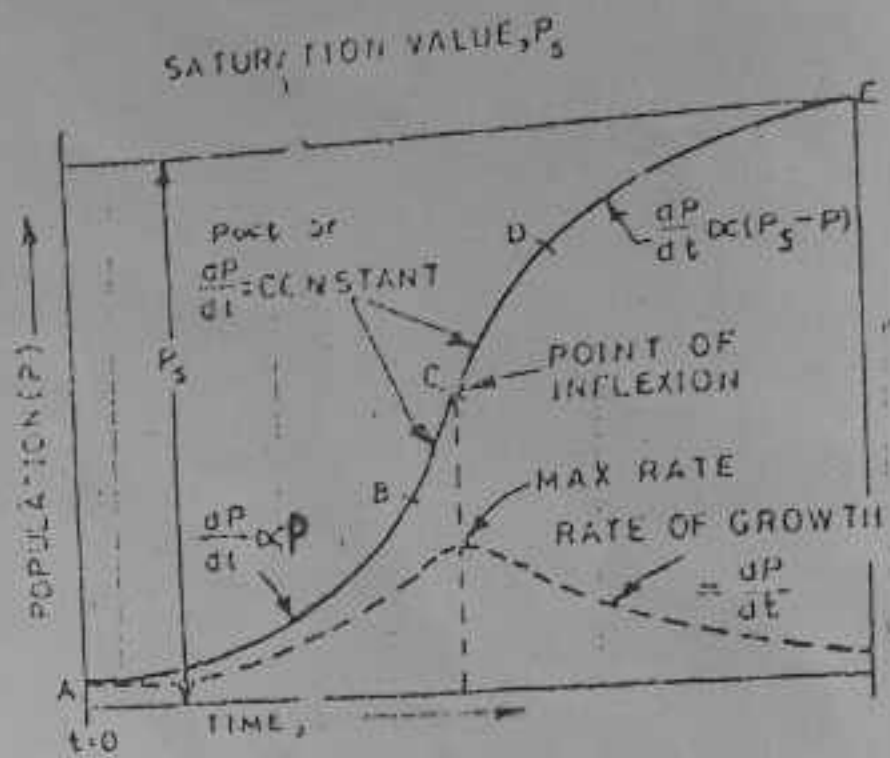

Fig. 1.1 Logistic Curve

$$P_v = \frac{2P_0P_1P_2 - P_1^2(P_0 + P_2)}{P_0P_2 - P_1^2} \quad a = \log_e \left(\frac{P_v - P_0}{P_0} \right) \text{ and } b = \left(\frac{1}{N} \right) \log_e \left(\frac{P_0(P_v - P_1)}{P_1(P_v - P_0)} \right)$$

Here N - time interval between successive census

6. Simple Graphical Method (Graphical extension method):

- ✓ Curve from the previous data (Population Vs Time) is plotted and curve smoothly extended according to its nature up to the desired year then

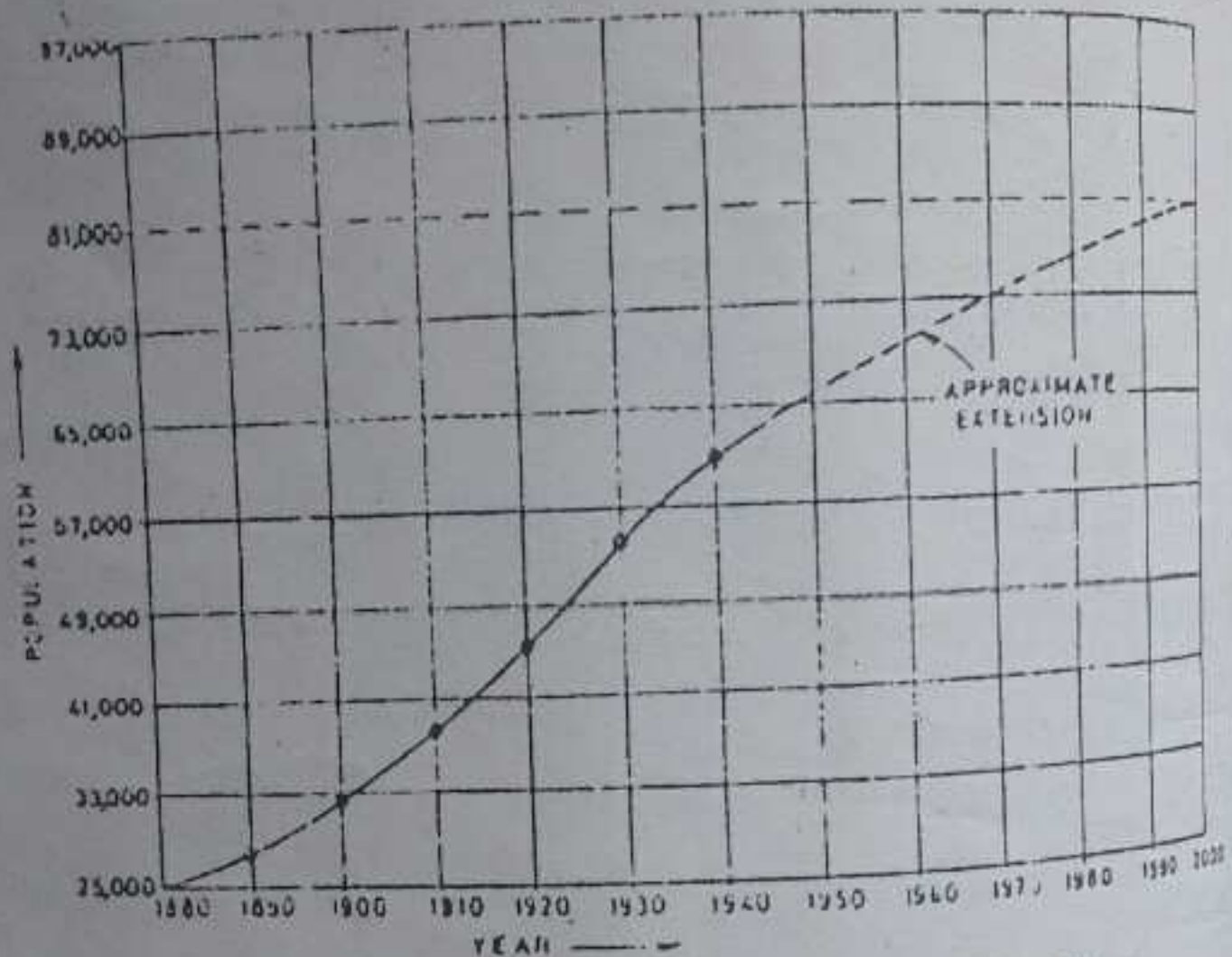

Fig 3.2 Graph of Population versus Time

population for that year is found graphically (See fig 3.2).

- ✓ Method is probably the most useful but unsafe to use this method alone because it gives only approximate results.
- ✓ Hence it is useful for providing check to the other methods.

7. Comparative Graphical Method (Graphical comparison method):

- ✓ From the past census of the city under consideration the curve of population versus time up to present time is first plotted then the cities having similar conditions, same level of development and characteristics similar to the city is chosen and their census is collected. Now these values are plotted on the same graph paper considering present time as datum. See fig 3.3).
- ✓ The curve of expected development of city under consideration is extended comparing with the other curves similar to this city.
- ✓ Useful for that city whose level of development is similar to the other cities.

8. Master Plan or Zoning Method:

- ✓ The master plan of city is prepared by the concerned authority and future expansion is strictly regulated by various laws.
- ✓ City is divided into various zones and the population densities for various zones are fixed so that the population can be forecasted as per master plan.
- ✓ For example, if there are 10,000 plots in a zone of a city and by law only 5 persons in a plot is allowed to live, the maximum population in that zone is 50,000 numbers (5×10000) at fully developed stage.

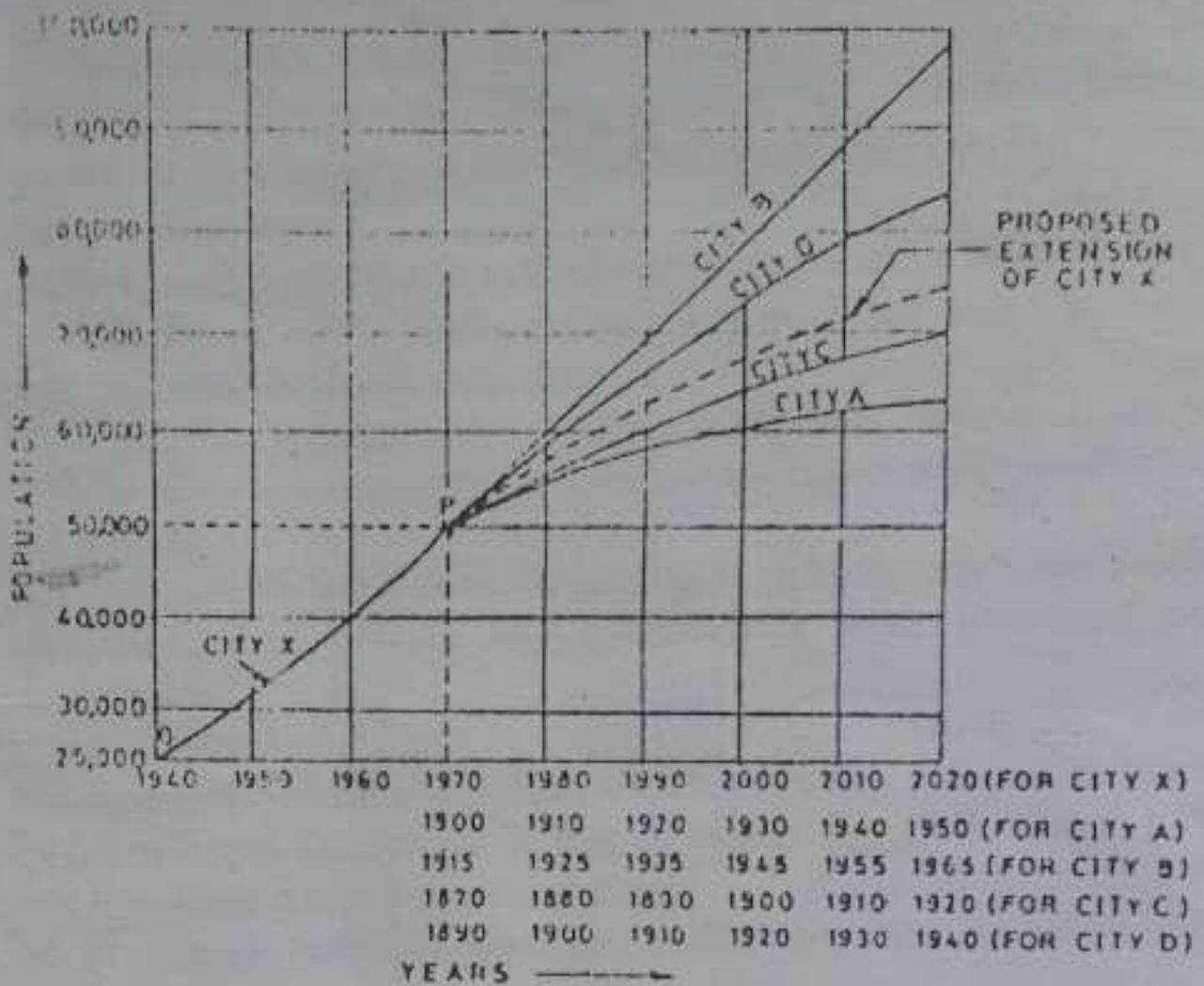

Fig 3.3 Comparative Graph of population versus Time

- ✓ Hence this method is useful for well planned cities.

9. Apportionment or Ratio Method:

- ✓ Just like simple graphical method, but the plot is the ratio of population of particular place to the national population versus time.
- ✓ The National, zonal, district, town etc population is recorded by the census department and the ratio of population of that particular place to national population is found.
- ✓ Now the plot of that ratio versus time is extended up to the desired year then corresponding ratio is determined.
- ✓ This ratio is further multiplied by the expected national population on that time.
- ✓ Suitable for areas whose growth rate is parallel to the national growth.



CHAPTER 4. QUALITY OF WATER

4.1 IMPURITIES IN WATER

- Quality of water is the degree of goodness of characteristics (physical, chemical & biological) of water in all aspects.
- Condensation of water vapor, make rainfall, but this water initially is pure containing two parts of hydrogen and one part of oxygen only by volume. On the way of falling, it absorbs different gases, dust & other impurities. Also during surface runoff, this water carries large number of impurities such as silt, organic, non-organic, minerals impurities, suspended matters etc. while moving on earth surface. These substances not always be harmful but may be useful to human life. Again ground water contains both harmful & useful gases and minerals.
- Before using water for drinking, water treatment is needed. Total purification is difficult & costly and pure water only is not good for our health hence treatment to some extent is done.
- To ensure whether the water from any selected source drinkable (wholesome) or not and to ensure the treatment needs, quality of water should be known.
- All undesirable substance containing in water in any form is called impurities in water. Water from any source may have following three types of impurities

a. *Suspended impurities:*

- ✓ These are those impurities, which normally remains in suspension due to same specific gravity as that of water. Eg. Clay, algae, fungi, organic & inorganic matters & minerals etc.
- ✓ It causes turbidity and suspended impurity is measured in terms of turbidity.
- ✓ Concentration of suspended impurities is measured by turbidity test can be removed by sedimentation (larger ones) & filtration (finer ones).

b. *Colloidal impurities:*

- ✓ These are the small, non-visible with naked eye and electrically charged particles, which remain in, continue motion.
- ✓ These materials generally associated with organic matters containing bacteria.
- ✓ Their size is between 10^{-3} mm to 10^{-6} mm.
- ✓ The charge is due to absorbed ions on the solid particles. Eg. Acids or neutral materials as silica glass & most organic matters have negative charge in neutral water and Basic materials as Al_2O_3 & Fe_2O_3 are positively charged.
- ✓ Particles of similar charged materials repel each other, which cause movement of the particles.

✓ It causes color in water and these impurities cause epidemics because the organic matters contain bacteria.

✓ It is measured by colour test and difficult to remove by ordinary filters.

c. Dissolved impurities:

Some solid liquid and gas dissolves in the water when it moves over the rocks and soil etc because water is the good solvent. Eg: non-visible organic compounds inorganic salts & gases etc.

It makes bad taste, hardness and alkalinity. Its concentration is measured in PPM (parts per million) or mg/l and obtained by weighing the residue after evaporation of the water sample from a filtered sample.

IMPURITIES IN WATER

Type	Consistent	Effect
1. Suspended impurities	a. Bacteria b. Algae, Protozoa c. Clay, Silt	a. Some cause disease b. Odour, turbidity & color c. Turbidity
2. Dissolved impurities	a. Calcium & Magnesium i. Bi carbonate ii. Carbonate iii. Sulphate iv. Chloride	i. Alkalinity <i>hardness</i> ii. Alkalinity & hardness iii. Hardness iv. Hardness, corrosion
	b. Sodium i. Bicarbonate ii. Carbonate iii. Sulphate iv. Fluoride v. Chloride	i. Alkalinity, softening effect ii. Alkalinity, softening effect iii. Foaming in boilers iv. Dental flurosis or mottled enamel <i>tooth de</i> v. Taste <i>salty</i> <i>fluros</i>
	c. Metals & compounds i. Lead ii. Arsenic iii. Iron oxide iv. Maganese v. Barium vi. Cadmium vii. Cyanide viii. Boron ix. Selenium x. Silver xi. Nitrates	i. Cumulative poisoning ii. Toxicity, poisoning iii. Taste, red colour, corrosiveness, hardness iv. Black or brown color v. Toxic effect on heart, nerves vi. Toxic, illness vii. Fatal viii. Affect central nervious system ix. High toxic to animals & fish x. Discolorations of skin, eyes xi. Blue baby conditions, infant poisonings, colour & acidity
	d. Gase i. Oxygen ii. Carbon iii. Hydrogen sulphide	i. Corrosiveness to metals ii. Acidity, Corrosiveness iii. Odour, acidity & corrosiveness
3. Organic Impurities (Colloidal)	a. Vegetable b. Animals (dead) c. Animals (live)	a. Colour, taste & acidity, produces bacteria b. Produce harmful disease germs c. Causes pollution of water & produces disease germs.

4.2 LIVING ORGANISM IN WATER

- Contaminated water may contain various microorganisms and hence should be treated before use otherwise this water may spread diseases.
- Micro organisms which require living tissue to grow and reproduction are called pathogens which are very harmful to human being while majority of others microorganisms are beneficial.
- There are various types of living organisms in water. Eg: algae, bacteria, worms, protozoa, viruses, fungi, amoeba etc. Some of them are as follows:

1. Algae:

- ✓ A unicellular simple photosynthetic aquatic plant which is self nourishing (having chlorophyll) by deriving energy from simple inorganic substances (eg; gases and dissolved salts in water) with the help of sunlight is called algae. It releases oxygen in photosynthesis.
- ✓ It has no root system and is microscopic in fresh water but several hundred meters in length in salty water.
- ✓ Seven types of algae have been found.
- ✓ Effects of algae:
 - Causes turbidity, colour, objectionable odour and unpleasant taste
 - Clogging of filter bed in treatment plants
- ✓ Adding copper sulphates in the water can control growth of algae.

2. Bacteria:

- ✓ Bacteria are the single celled animal type minute microorganism possessing no defined nucleolus and having no chlorophyll for making its own food.
- ✓ Reproduction by binary fission and normally present in contaminated water.
- ✓ Sizes are of 1 - 4 microns and can't be seen with naked eye and can be seen through microscope.)
- ✓ Bacteria are classified in different basis as follows:

a. As per shape:

- i. Spherical bacteria (Cocci):
They are micrococcus(singly), diplococcus(in pairs), streptococcus(in chains) and staphylococcus (in irregular bunches)
- ii. Straight bacteria(Bacilli)
- iii. Curved bacteria(Vibrio)
- iv. Spiral bacteria(Spirilla)
- v. Trichobacteria (filamentous)

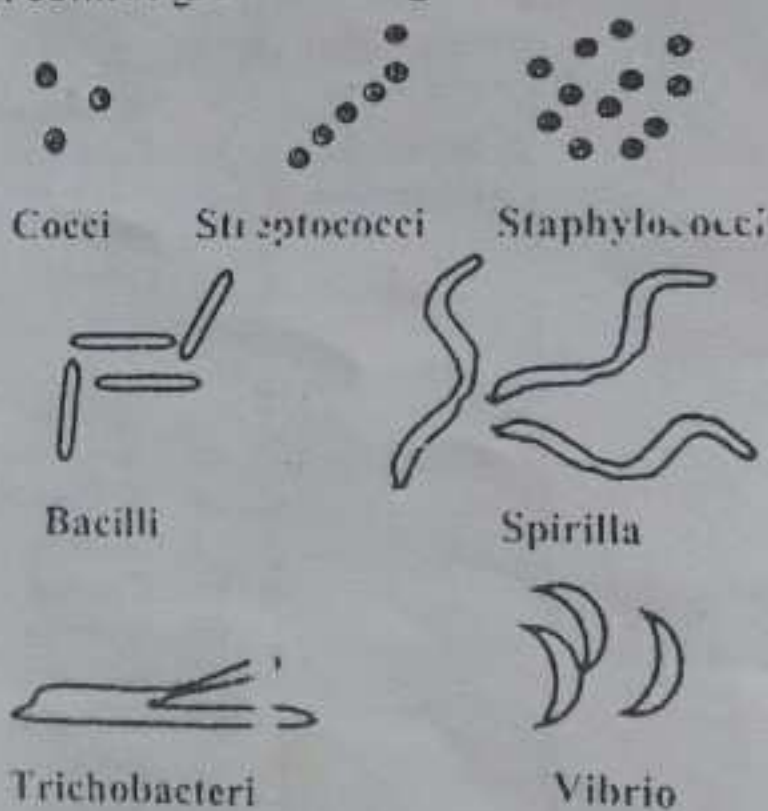

Fig 4.1 Types of Bacteria as per Shape

b. As per Type:

- i. *Saprophytic bacteria*: Bacteria, beneficial to man, which survives with organic materials from dead bodies and animals.
- ii. *Parasitic bacteria*: Bacteria which survives within the body of living organism and also causes disease.
- iii. *Pathogenic bacteria*: Bacteria capable of causing diseases.
- iv. *Non-pathogenic bacteria*: Bacteria which does not cause diseases.

c. As per oxygen need:

- i. *Aerobic bacteria*: Bacteria which need oxygen for survival
- ii. *Anaerobic bacteria*: Bacteria which survives without oxygen
- iii. *Facultative bacteria*: Bacteria surviving in presence or absence of oxygen

d. According to temperature survival:

- i. *Psychrophilic bacteria*: Bacteria which survives in $10 - 20^{\circ}\text{C}$
- ii. *Mesophilic bacteria*: Bacteria which survives in $20 - 40^{\circ}\text{C}$
- iii. *Thermophilic bacteria*: Bacteria which survives in $40 - 65^{\circ}\text{C}$

e. According to origin of occurrence:

- i. *Natural water bacteria*: Bacteria naturally found in water.
- ii. *Bacteria from soil*: Bacteria derived from soil.
- iii. *Bacteria from sewage and animal excreta*:

- *Clostridium welchii*: These bacteria are found in intestines; cause no harm but helps in digestion.
- *Faecal streptococci*: These bacteria are found in intestines; uses bile salt; not much in number hence not necessary to test unless in doubt.
- *Coli-aerogenes (coliform) group*: Coliforms are Bacilli type indicator organism which is not harmful to men. They are found in the intestines of men and warm blooded animals. Through excreta, about 10^{11} to 10^{12} numbers of bacteria per capita per day is thrown away. These are commonly called *Escherichia coli* (E-Coli).

3. Virus:

- ✓ It is a unicellular animal type living organism and infectious for plant and animal cells. It grows in animal organ and dies if left in air.
- ✓ It is ultra-microscopic in size (i.e. $10 - 500$ milli-microns) and a typical virus particle consists of an outer protein coat enclosing a core of nucleic acid.
- ✓ Relation with water is still unknown but causes diseases like paralysis, hepatitis, throat diseases, etc.
- ✓ Water can be prevented from virus by adding high amount of chlorine.

4. Worms (Helminthes):

- ✓ Worms are microscopic as well as macroscopic and can enter directly to the human body through skin or on drinking of water.
- ✓ They may be parasitic as well as free living. Hook worm, tape worm etc are parasite.

Classified as:

- (a) Nematodes or round worms
- (b) Rotifers
- (c) Flat worms (Platy helminthes). Further divided into two:
 - (i) Tape worms (Cestodes)
 - (ii) Flukes (Trematodes)

Worms causes schistosomiasis.

5. Indicator Organisms:

- ✓ Water contains both harmful (pathogenic) as well as harmless (non-pathogenic) bacteria which are beneficial under certain conditions to humans, animals and plants. Generally they occur together in water and they are difficult to detect pathogenic bacteria because their presence number may be very small and irregular even in sewage polluted water.
- ✓ On the other hand, the sewage water may contain large number of particular type of non pathogenic bacteria called coliforms. They are largely found in the large intestine of human and animals and excreted with their faeces. The evidence of presence of pathogenic bacteria is indirectly obtained by testing these coliforms are called indicator organisms.
- ✓ E-Coli (Escherichia Coli) are commonly used as indicator organism since they present in larger numbers.
- ✓ The absence of E-Coli almost justifies the assumption that the faecal polluted water is free from pathogen. This justification mayn't be true for other pollutions.

058ch8

4.3 WATER RELATED DISEASES

- Diseases which are related to water may be very infectious are called to water related disease.
- Water related diseases can be grouped into following:

1. Water Borne Disease:

- ✓ If water, carrying pathogens entered into the body with drinking water, they cause disease which is called Water Borne Disease. Eg: Typhoid (by Salmonella typhi bacteria), Paratyphoid (by Salmonella paratyphi bacteria), Cholera (by vibro cholera bacteria), Hepatitis (by hepatitis virus), Dysenteries (by shigella bacteria), Diarrheas, Amoebic dysentery and other Bacterial, Viral, Protozoal diseases
- ✓ These diseases are spread through water supplies hence it can be prevented by improving quality of drinking water.

2. Water Washed Disease:

- ✓ The disease caused due to lack of personal hygiene is called Water Washed Disease. Eg: Skin sepsis, Scabies, Trachoma (eye inflammation), fungal infection, Infection carried by lice etc.
- ✓ For prevention, increase the quantity of water.

3. Water Based Disease:

- ✓ Disease or infection transmitted through aquatic animal and pathogens which spend their life cycles in water is called Water Based Disease. Eg: Water snail - schistosomiasis, Guinea worm, Prilhasia, Lingo flukes etc.
- ✓ For prevention, do not contact with infected water.

4. Water Related Vector or Insect Dependent Disease:

- ✓ Insects that live in surrounding of water may transfer disease, carrying pathogens with them are called Water Related Vectors and the water related infections or diseases transferred from water by insects are called Insect Dependent Disease. Eg: Sleeping sickness, Filariasis, Malaria, River blindness, Yellow fever, Dengue, Hook worm etc.
- ✓ For prevention, improvement on surface water should be done.

Disease Transmission Route (Faecal - Oral Transmission):

- ✓ Organisms from the urine and faeces reach to the water sources from sewage disposal or other various ways and then this water is transmitted in the human body orally from the food or contaminated water and called faecal oral transmission. *→ waste matter passed from bow*
- ✓ Water borne and water washed diseases are spread by means of faecal oral transmission through hands, cloths, utensils etc. *→ by the mouth.*
- ✓ In developing countries, the disease transmitting means is water from faecal-oral group.

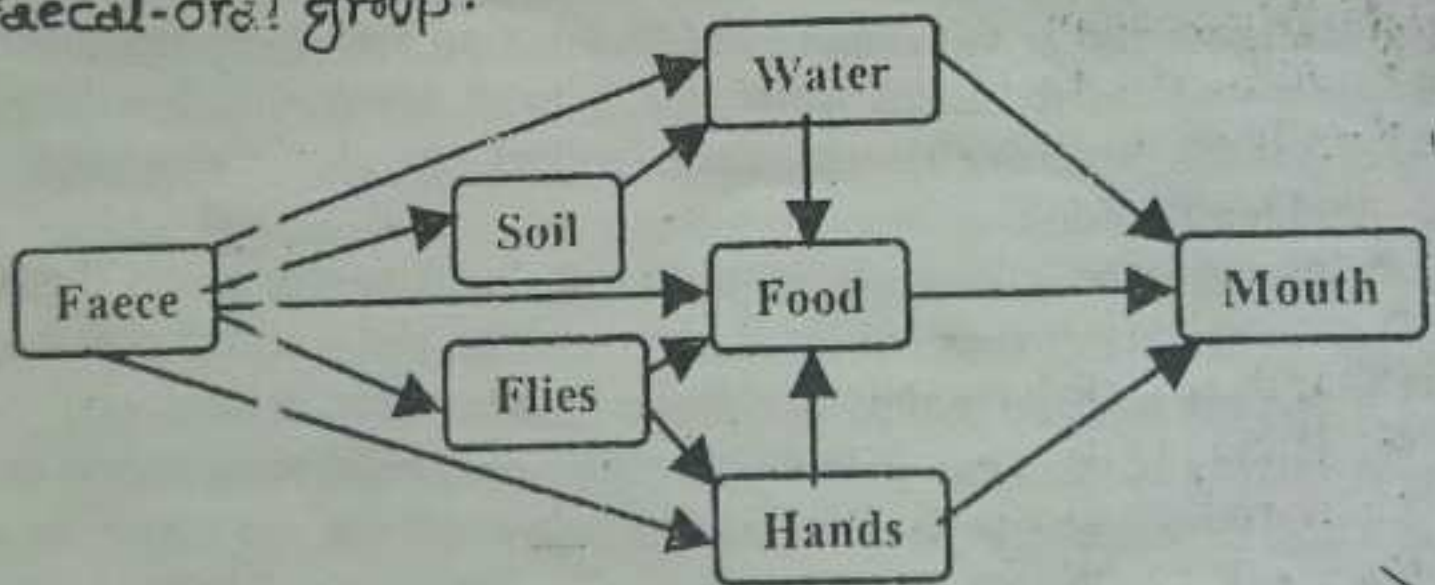

Fig 4.2 Pathways of Faecal - Oral Transmission of Diseases

- ✓ Preventive measures from faecal-oral transmission of diseases are as follows:
 - Wash hand before meal. Stool test
 - Keep food/water on covering
 - Make and use toilets, keep toilets fresh
 - Tap water always from upstream of the possible contamination place.
 - Use safe water.

4.4 EXAMINATION OF WATER

- To examine the quality of water a series of lab tests are done in systematic manners, this is called the examination of the water.
- Fully equipped lab for examination of water is required for water supply schemes in the city.
- The main purposes of examination are given below:
 1. To ascertain the quality of water and quantity of various impurities.
 2. To know the outline of the treatment process for required quality.
 3. To make daily treatment in treatment plants.
 4. To check the treat water is as per standard or not.
- Before examination, collection of water samples should be done in proper manner so that it is the true representative and small volume to be transported in the lab.
- The procedure for collection of water samples are as follows:
 1. For physical examination it can be collected in fully cleaned bottles or buckets or jarricans etc but for chemical and biological tests bottles of greater than 2 liters capacity are used.
 2. Clean and rinse the containers/bottles and give final rinse with distilled water and close it with clean stopper or lids until sample collection.
 3. At collection keep the stopper/lids clean and collect sample living certain air in the bottle then recap it so that shaking is possible before testing. This collected sample should be true representative of water to be tested so use septic techniques to avoid sample contamination.
 4. When sample is collected from distribution system or tap, open the tap fully and let to waste water for 2 to 3 minutes and reduce flow to eliminate stagnant water then collect in the clean and sterilize container/bottle.
 5. When sample is taken from well with hand pump, pump the water for about 5 minutes then collect it into the clean and sterilize container/bottle. If there is no hand pump, take the well water directly from well.
 6. If sample is taking from river, streams, lake, reservoirs, spring or shallow wells, take water from 40 to 50 cm below the surface not so far and near the draw-off site.
 7. As far as possible testing (considering microbiological tests) should be done within 1 hours of collection. If it is not possible, use ice or cooler which extend the time up to 24 hrs.
- The tests to examine water can be classified as follow :
 - A. Physical examination
 - B. Chemical examination
 - C. Micro-biological examination
- A. Physical Examination:

It includes the following:

 - a. Temperature
 - b. Colour
 - c. Turbidity
 - d. Taste and odour

a. Temperature:

✓ Density, viscosity, vapor pressure and surface tension of water is related to the temperature of water. Chemical, Biochemical and biological activity also depends upon temperature.

✓ Temperature of water is determined from ordinary thermometers/digital meters.

✓ Temperature of surface water is equivalent to the atmospheric temperature whereas that of ground water may be more or less than atmospheric temperature.

✓ For public water supply it should be between 4.4°C to 10°C , greater than 25°C is undesirable and greater than 35°C is unfit.

b. Colour:

✓ Colour in water is due to organic matters in colloidal condition and mineral & dissolved impurities (iron, manganese etc), decayed vegetable matter, weeds, humus, plankton and industrial wastes.

✓ It makes water in undesirable appearance which is disliked by the people and it may spoil clothes and affect industrial processes.

✓ It can be measured by platinum cobalt method.

• In this method various standard solutions is made by dissolving various amount of platinum cobalt in distilled water and the colour water sample is compared with these solutions using tintometer.

• A tintometer consists of an eyepiece with two holes inside. In one hole slide of colour of standard solution and in other slide of colour of water sample can be see.

• The standard coloured solution is changed until the two slides matches and the colour of the sample is same as that of that standard solution in cobalt scale.

1 platinum cobalt scale = 1 ppm = 1 mg/l = colour obtained from the solution of 1 mg of platinum cobalt in 1 liter of water

✓ For field use, the tintometer is not useful hence the colour of sample is compared with special calibrated glass colour discs in cobalt scale and the value of the matched gives the colour of the water sample.

✓ For drinking water colour should not be greater than 5 ppm in platinum cobalt scale. Greater than 5 is tolerable but rejected if it is greater than 25 ppm in platinum cobalt scale is undesirable and greater than 35°C is unfit.

✓ Colour is removed by sedimentation, filtration, aeration and use of chemicals.

c. Taste and odour:

✓ Taste of water may be bitter, salty, sour, sweet, unpleasant earthy, fishy, grassy etc due to the presence of dissolved gases, salts, organic matters, suspended particles aquatic life etc.

- ✓ Taste is measured by Flavour threshold test, odour by Threshold odour test and expressed in terms of Flavour Threshold Number (FTN) and Threshold Odour Number (TON) respectively.
- ✓ For this test the water sample of known volume is mixed with taste and odour free water up to the quantity which makes the sample diluted to just taste and odour free respectively. Then FTN and TON is given by,

$$\text{FTN or TON} = \frac{A+B}{A}$$

Where, A = Volume of water sample,
B = Volume of taste/odour free water added

- ✓ FTN & TON should not greater than 3, preferably 1 for drinking water.
- ✓ Taste and odour is removed by aeration and chemical treatment.

d. Turbidity:

- ✓ Turbidity is defined as the measure of the degree of clarity of water.
- ✓ It is caused by suspended matters (clay, silt etc), organic & inorganic matters, plankton, other microscopic organisms etc and causes water aesthetically unattractive.

- ✓ Turbidity should be between 5 - 10 ppm in silica scale. Turbidity of 2.5 ppm is accepted and rejected if it is greater than 25 ppm in silica scale.

1 ppm = 1 mg/l in silica scale = turbidity obtained from the solution of 1 mg of silica in 1 liter of water

- ✓ In field turbidity is measured using turbidity rod.

- Turbidity rod consists of an aluminum rod of about 203 mm long and graduated in ppm of silica scale. A screw containing a standard platinum needle (1 mm diameter & 25 mm long) is inserted at the lower end of the rod as shown in fig 4.3.

- For test, a vertical stick is inserted in the nickel ring to support and keep the rod in position. The graduated aluminum rod is lowered in water at the depth, where platinum needle ceases to be seen (keeping eye at eye mark) under light conditions and the value can be read on the graduated scale near the water surface.

- This method gives rough value only.

- ✓ In lab the turbidity is measured with the help of the following instruments:

- | | |
|--|-----------------------------|
| (i) Jackson turbidity meter | (ii) Baylis turbidity meter |
| (iii) Hellige or Aplab turbidity meter | (iv) Nephelometer |

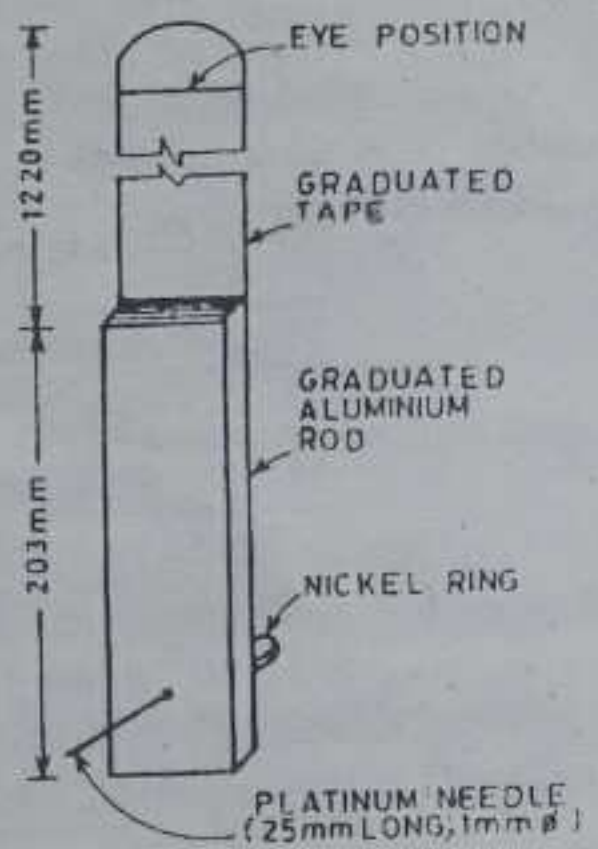

Fig 4.3 Turbidity rod

i. Jackson turbidity meter:

- It consists of a graduated glass tube placed in a metal cylindrical container which is supported in standard stand and a standard candle is placed as shown in the fig 4.4.
- To measure the turbidity, candle is lighted, some quantity of water is placed into the glass tube and image of candle is observed from the top of glass tube.
- The depth of the water is increased by adding sample to the tube till the image of the candle ceases to be seen.
- The depth of water at this stage is noted and turbidity with respect to this height is determined in Jackson turbidity unit (JTU) from the standard table.
 $1 \text{ JTU} = 1 \text{ mg/l} = 1 \text{ ppm}$ in silica scale.

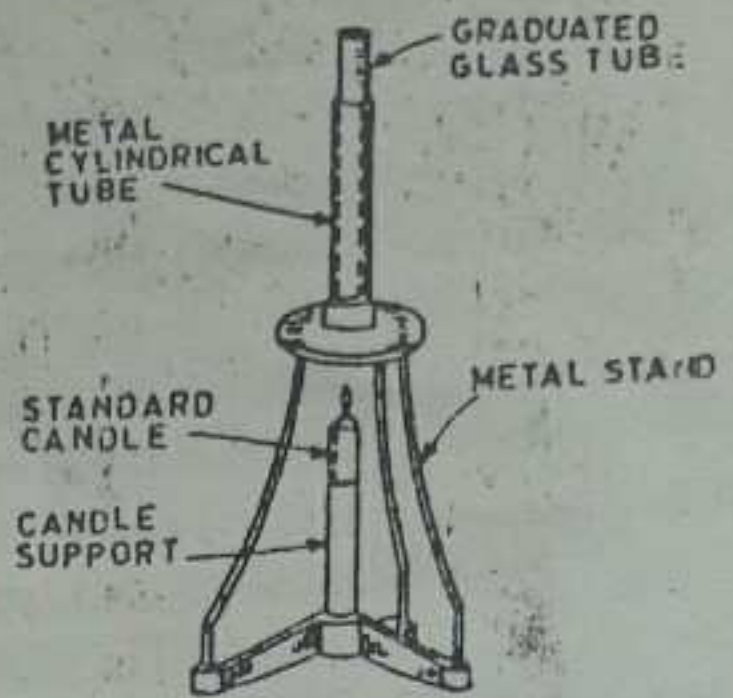

Fig 4.4 Jacksons turbidity meter

ii. Baylis turbidity meter:

- It consists of a closed galvanized iron box, on one side of which there are two glass tubes and on the other side there is a 250 watt electric bulb with reflector as shown in the fig 4.5.

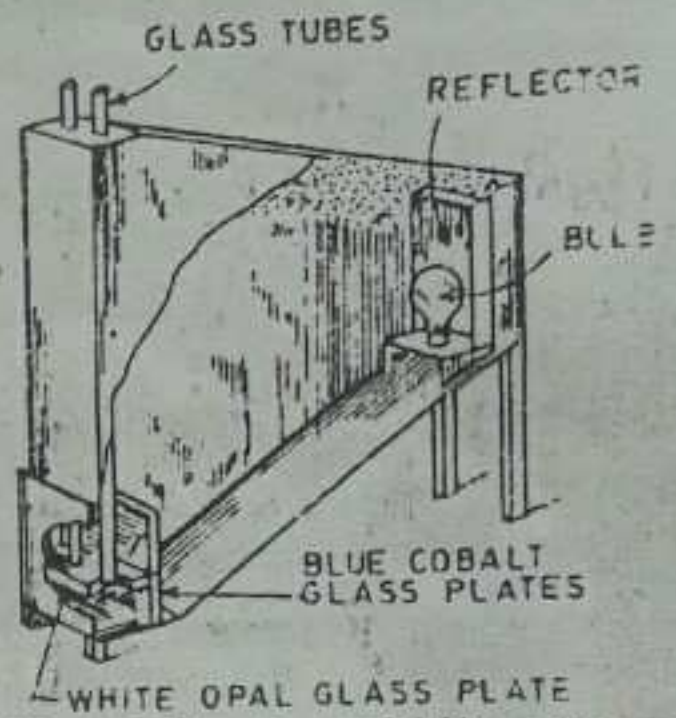

Fig 4.5 Baylis turbidity meter

- For test, one glass tube is filled with sample water and other with standard solution of known turbidity. The bulb is lighted and the colour of blue light can be seen from both sides. If colour differs, change the standard solution until the colour matches. The value of the standard solution in this case gives the turbidity value of water sample.
- It is the accurate method and precision is up to 0 - 2 ppm.

iii. Hellige or Aplab's turbidity meter:

- It consists of a closed mild steel cabinet with different accessories as shown in fig 4.6. It has a graduated adjustable shutter knob.
- For test, keep the water in the cell up to the mark and close the door of

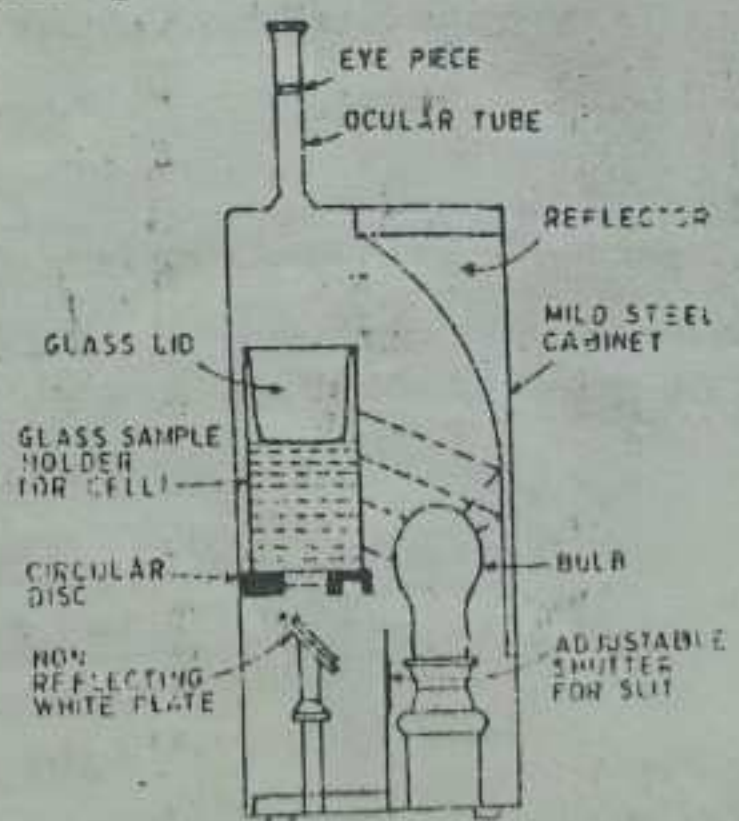

Fig 4.6 Hellige turbidity meter

the cabinet then light the bulb. Observe : cattered light and sample sidewise from circular tube and adjust the turning knob until colour of light through sample below and scattered light matches.

- The dial reading in turning knob gives the turbidity value in ppm in silica scale.

iv. Nephelometer and digital turbidity meters:

- These are the modern commercial turbidity meters, which gives turbidity value directly in digital display after calibration with standard turbidity solutions. It is described in lab class.

B. Chemical Examination:

It includes the following:

- a. Total solids b. pH or hydrogen ion concentration c. Hardness
d. Metals and other chemical substances e. Chlorides f. Nitrogen

In our course we are concerned with a to c which are described below.

a. Total solids:

- ✓ Total solids (TS) means the total dissolved and suspended solids present in water.

- ✓ Total suspended solids (TSS) are smaller in quantity than total dissolved solids (TDS).

✓ Determination of total solids (TS):

Place 100 to 300 ml of water in the crucible and evaporate it to dryness in an oven at 105°C. Take wt. of dry residue left in the crucible.

$$TS = \frac{\text{wt. of dry residue left in crucible in mg}}{\text{Volume of water sample taken in crucible in liter}} \text{ (mg/liter or ppm)}$$

✓ Determination of total dissolved solids (TDS):

Take Whatman filter paper no 44 and take measured volume of filtered water through this filter paper in a crucible then evaporate it to dryness in an oven of 105°C. Take wt. of dry residue left in the crucible.

$$TDS = \frac{\text{wt. of dry residue left in crucible in mg}}{\text{Volume of water sample taken in crucible in liter}} \text{ (mg/liter or ppm)}$$

✓ Determination of total suspend solids (TSS):

$$TSS = TS - TDS \text{ Alternatively,}$$

Take Whatman filter paper no 44 and filter the known volume of water. Take wt. of dry residue left on the filter paper. Then,

$$TSS = \frac{\text{wt. of dry residue left in filter paper in mg}}{\text{Volume of water sample filtered in liter}} \text{ (mg/liter or ppm)}$$

- ✓ TDS should not be greater than 500 mg/l, 500 - 500 mg/l is tolerated and 1500 mg/l is the maximum permissible limit for water for human consumption.

pH or hydrogen ion concentration:

- ✓ The water found in nature may be acidic or basic depending on the nature of dissolved salts and minerals.
- ✓ The acidity and alkalinity is measured in terms of pH value because pH value indicates the hydrogen ion concentration in water.
- ✓ Water (H_2O) is the combination of positively charge of Hydrogen ions (H^+) or cations and negatively charged Hydroxyl ions (OH^-) or anions and in pure water the concentration of H^+ ions and OH^- ions are equal.
- ✓ When some substances is dissolved in pure water, the solution formed ionized (i.e. splits up into H^+ and OH^- ions) and the balance between the concentration of the same are disturbed.
- ✓ If concentration of H^+ ion is greater then the water is acidic and alkaline if that of OH^- ion is greater. For example, if HCl is added, the water becomes acidic and if NaOH is added it becomes alkaline.

Acidic, if:

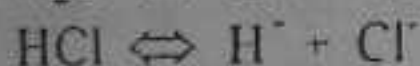
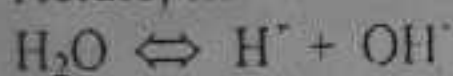

Alkaline, if:

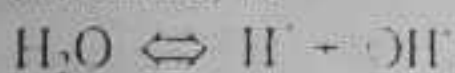

- ✓ Law of Mass Action in Physical Chemistry states that the ratio of the product of concentration of ions and anions to the concentration of undissociated molecules remains constant. For water mathematically,

$$\frac{[H^+][OH^-]}{H_2O} = K_w, \text{ Where } K_w = \text{ionization constant} = 10^{-14} \text{ at } 25^\circ C$$

Since dissociation is water is very small hence it can be neglected then,

$$[H^+][OH^-] = 10^{-14}$$

Also for pure water concentration of $[H^+]$ and $[OH^-]$ is equal so,

$$\therefore [H^+] = 10^{-7} \text{ moles/l}$$

[moles = molecular wt in gram]

- ✓ Hence in a pure water solution, the hydrogen ion concentration is found to be 10^{-7} moles/liter

- ✓ The pH is defined as the logarithm of the reciprocal of hydrogen ion concentration. Mathematically,

$$pH = \log_{10} \frac{1}{[H^+]} = \log_{10} [H^+]^{-1} = -\log_{10} [H^+] = -\log_{10} [10^{-7}] = 7$$

It shows that pH of neutral water is 7.

- ✓ The pH scale shown in fig 4.7 explains the variation of alkalinity and acidity.

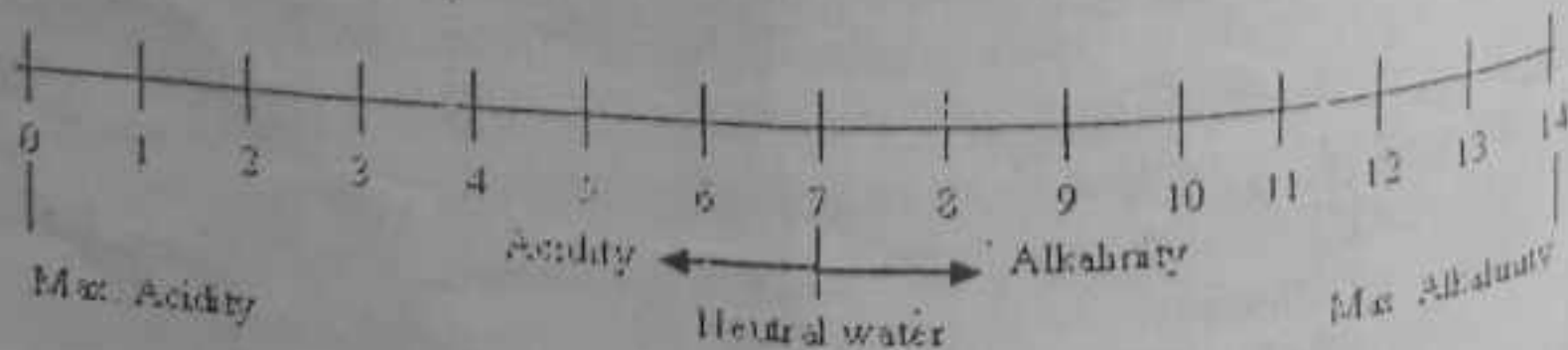

Fig 4.7 A pH Scale

Acidity in water is caused by the presence of mineral acids, free carbon dioxide, sulphates of iron, aluminum etc, whereas alkalinity is caused by the presence of bicarbonates of calcium and magnesium or carbonates of hydroxide of sodium, potassium, calcium and magnesium.

pH of 6.5 to 8.5 should be acceptable and rejected if pH is <6.5 to >9.2 for public water supply. Hence pH value should be as closer to 7.

The lower value of pH (acidic) causes corrosion and the higher (alkalinity) produce sediment deposits, difficulty in chlorination etc.

The pH value of water can be measured by:

(i) Colorimetric method (ii) Electrometric method

i. Colorimetric method:

- In this method some indicator (such as methyl orange, methyl red etc) is added to the water sample till the colour changes from original to final colour of given indicator.
- This colour produced is then compared to the colour tubes, glass discs and charts supplied by the manufacturers and pH is determined.

ii. Electrometric method:

- This is the instrument which measures the pH and displays in the display.
- The instrument is first calibrated using two standard solutions of known pH and then it is ready to use of pH measurement. (Detail is discussed in lab).

c. Hardness of Water:

Definition of Hardness:

✓ Hardness is the chemical characteristics of water which prevents the formation of sufficient lather or foam when mixed with soap.

Causes of Hardness:

- ✓ Mainly it is caused by the presence of bicarbonates, sulphates, chlorides and nitrates of calcium and magnesium.
- ✓ Fe (Iron), Mn (Manganese), Sr (Strontium) salts also may cause hardness but their presence in most of water is negligible so practical purpose it is not counted.

Effect of Hardness:

✓ Following are the effect of hardness in water.

1. Wasteful consumption of soap while washing and bathing.
2. Modifies colour if used in dyeing work and washing clothes.
3. Produces scale in steam boiler and its pipe which reduces heat transfer and finally cause leak.
4. Causes corrosion and incrustation of pipelines and fittings.
5. Scale formation further causes corrosion, caustic brittleness, decreases efficiency and danger of burst of pipe line and boiler
6. Makes food tasteless, more fuel consumption and causes bad effect to our digestive system.

Types of Hardness:

✓ There are two types of hardness:

a. Carbonate or Temporary Hardness (CH):

- The hardness caused by the presence of carbonate and bicarbonate of calcium and magnesium is called carbonate hardness.
- Since it can be removed by boiling or by adding lime so it is called temporary hardness.
- On boiling, CO₂ is escaped and insoluble CaCO₃ gets precipitated. So temporary hardness causes deposition of Ca scales in boilers.

b. Non carbonate or permanent hardness (NCH):

- The hardness caused by the presence of sulphates, chlorides and nitrates of Ca or Mg is called non carbonate hardness.
- Such hardness from water can't be removed by simple boiling but requires special treatment of softening hence it is called permanent hardness.
- The total hardness is the sum of carbonate hardness and non-carbonate hardness. Mathematically,
T.H. = CH + NCH

Alkalinity in Water and its Causes:

- ✓ When pH of water is > 7, it is said to be alkaline. If pH = 14, maximum alkalinity is achieved.
- ✓ Generally alkalinity is caused by hydroxides, carbonates and bicarbonates but most natural alkalinity is due to bicarbonates, which are produced by the action of ground water on limestone or chalk as

$$\text{CaCO}_3 + \text{H}_2\text{O} + \text{CO}_2 \rightarrow \text{Ca}(\text{HCO}_3)_2$$

(Insoluble) (From soil bacteria) (soluble)
- ✓ Alkalinity caused by hydroxides is called hydroxide alkalinity or caustic alkalinity, caused by carbonate is carbonate alkalinity and caused by bicarbonate is called bicarbonate alkalinity.
- ✓ Some but not all the compounds causing alkalinity also causes hardness.

Relationship between Alkalinity and Hardness:

a. When total hardness is greater than the total alkalinity (TA) of water then the amount of hardness is equivalent to TA is equals to the carbonate hardness (CH) and the amount of hardness in excess of this is equal to the non carbonate hardness (NCH). Mathematically,

If, TH > TA, then,

$$\text{CH} = \text{TA} \text{ and } \text{NCH} = \text{TH} - \text{CH} = \text{TH} - \text{TA}$$

b. When the total hardness is equal to or less than total alkalinity then the entire hardness is the carbonate hardness and the non-carbonate hardness is said to be absent. Mathematically,

If, TH ≤ TA, then,

$$\text{CH} = \text{TH}, \text{ and } \text{NCH} = 0$$

Measurement of Hardness in Water:

✓ Hardness of water is measured in ppm. 0: mg/l of calcium carbonate present in water. Different levels of hardness of water as CaCO_3 are given below.

Range: (mg/l)	0 - 50	50 - 100	100 - 150	150 - 250	>250
Hardness level	soft	Moderately soft	Slightly hard	Moderately hard	Hard

✓ The hardness of water is also expressed as the degree of hardness. It may be Clark scale, French scale or American scale

Clark's scale:

1°Cl = Power of soap destroying is equivalent to the effect of 14.254 mg of calcium carbonate (CaCO_3) present in one liter of water which causes wastage of about 0.6 gm of soap in 1 liter of water (ie. 14.254 ppm).

French scale:

1°Fr = Power of soap destroying is equivalent to the effect of 10 mg of calcium carbonate (CaCO_3) present in one liter of water.

American scale:

1°Am = Power of soap destroying is equivalent to the effect of 17.15 mg of calcium carbonate (CaCO_3) present in one liter of water.

Test on Hardness in Water:

✓ Hardness is measured either by:

(a) Soap solution test

(b) Titration with EDTA (Ethylene Diamine Tetra-acetic Acid) using Erichrome Black-T as indicator

✓ The EDTA method is more accurate method from which the total hardness (TH) is measured. The wine red colour changed to distinct blue colour indicates the end of titration. The total hardness (TH) of the water sample is given in mg/l or ppm by the following equation.

$$\text{TH} = \frac{\text{ml of EDTA used}}{\text{ml of water sample taken}} \times 1000 \quad (\text{mg/liter or ppm})$$

Determination of Hardness from the results of chemical analysis:

1. Hardness is expressed in terms of equivalent amount of CaCO_3 as:

Hardness due to M^{++} as CaCO_3 ,

$$= \text{hardness as } \text{M}^{++} \text{ (in mg/l)} \times \frac{\text{chemical equivalent of } \text{CaCO}_3}{\text{chemical equivalent of } \text{M}^{++}} \quad \text{mg/l}$$

Where, M^{++} is any ion radical or hardness producing substance.

2. Alkalinity will be caused by positively charged Ca^{++} , Mg^{++} and Sr^{++} ions and negatively charged CO_3^{--} and HCO_3^- ions only. The readings

of other metals are ignored. The total alkalinity due to -ve charged ions is given by:

$$\text{Alkalinity due to } B^- \text{ as CaCO}_3 = \text{Total alkalinity as } B^- \text{ (in mg/l)} \times \frac{\text{chemical equivalent of CaCO}_3}{\text{chemical equivalent of } B^-} \text{ (mg/l)}$$

Where, B^- is any negative ion making alkalinity.

3. Atomic/molar mass:

H = 1, C = 12, O = 16, Ca = 40, Mg = 24.4, $\text{HCO}_3^- = [1 + 12 + 3 \times 16] = 61$, Sr = 87.6, $\text{CO}_3^{2-} = [12 + 3 \times 16] = 60$, $\text{CaCO}_3 = [40 + 12 + 3 \times 16] = 100$

4. Chemical equivalent (ce):

$\text{Ca}^{++} = 40/2 = 20$, $\text{Mg}^{++} = 24.4/2 = 12.2$, $\text{Sr}^{++} = 87.6/2 = 43.8$,
 $\text{HCO}_3^- = 61/1 = 61$, $\text{CO}_3^{2-} = 60/2 = 30$, $\text{CaCO}_3 = 100/2 = 50$

5. For measuring alkalinity, reading of only CO_3^{2-} or HCO_3^- will be required and expressed as %. Using equation in point 2 the values of the carbonate and bicarbonate alkalinities can be determined as:

$$\therefore \text{Total alkalinity as } \text{CO}_3^{2-} \text{ in mg/l} = [\text{carbonate alkalinity in mg/l}] \times 0.60$$

$$\text{Similarly, Total alkalinity as } \text{HCO}_3^- \text{ in mg/l} = [\text{bicarbonate alkalinity in mg/l}] \times 1.22$$

6. For drinking purpose total hardness (T.H.) < 200 mg/l.

Micro-biological Examination:

- ✓ It includes both bacteriological as well as biological examination.
- ✓ Biological examination is done to determine the presence of microscopic organisms other than bacteria (eg. Algae, fungi, yeasts, protozoa etc)
- ✓ The bacteriological analysis of water is done to determine the presence of bacteria and we are concerned to this only.
- ✓ The following three tests can be done for bacteriological examination.
 - a. Total count or agar plate test
 - b. Membrane tube fermentation technique
 - c. Membrane filter technique

a. Total count or agar plate test:

- In this method the water sample of 1 ml is diluted in 99 ml of sterilized water and this 1 ml of diluted water is then mixed with 10 ml of agar or gelatin (a culture medium used to cultivate bacteria) and kept in incubator at 37°C for 24 hrs (called hot count) or 20°C for 48 hr. (called cold count).
- Sample is then taken out from the incubator and colonies of bacteria are counted by means of microscope or colony counter.

Water Supply Engineering

- The total number of bacteria per ml of diluted sample is then calculated by the product of no of colonies and dilution factor.
- For potable water total count should not be greater than 100 nos/ml of sample.

* *b. Coliform/ E-coli test using membrane tube fermentation technique.*

- Testing the presence of pathogenic bacteria is done indirectly by testing of coliform group e-coli bacteria are generally done.

- This test is divided into following three:

- i. Presumptive test
- ii. Confirmed test
- iii. Completed test

i. Presumptive test:

- This test is based on the ability of coliform group (E-coli) to ferment the lactose broth and producing gas.

• Procedure:

1. Definite amount of diluted samples of water are taken in multiples of ten, such as 0.1 ml, 1.0 ml, 10 ml etc then it is placed in standard fermentation tubes containing lactose broth and then kept in the incubator at a temperature of 37°C for a period of 48 hrs.
2. If gas formed is seen in the tubes, it is the indication of presence of e-coli group and result is **+ve**. If no gas formed, the result is **-ve**.
3. **-ve** result in presumptive test indicates the water is fit for drinking.

ii. Confirmed test:

- The other bacteria than e-coli present also may ferment in presumptive test so the confirmed test to indicate E-coli is necessary.
- This test consists of growing cultures of coliforms (E-coli) on media which suppress the growth of other organisms.

• Procedure:

1. Small amount of incubated sample showing gas in presumptive test is carefully transferred to another fermentation medium containing brilliant green lactose bile broth and placed in the incubator at 37°C for a period of 48 hrs, if the gas formed, there is presence of E-coli is confirmed then step 2 is followed.
2. Again the small portion of incubated material showing gas in presumptive test is marked as streaks on the plates containing Endo or Eosin-methylene-blue agar and the plates are kept in the incubator at 37°C for a period of 24 hrs. If colonies of bacteria seen after this period, it indicates the presence of E-coli and completed test is necessary.

iii. Completed test:

- This test is based on the ability of the culture grown in the confirmed test to again ferment the lactose broth.

• Procedure:

1. The bacterial colonies or cultures grown in the confirmed test are kept into lactose broth fermentation tubes and agar tubes.
2. The tubes are then kept in the incubator at 37°C for a period of 24 to 48 hrs. If gases are seen in tubes after this period, it indicates the presence of E-coli and the test is +ve and it contains the pathogens. When detailed tests are necessary for pathogens.
3. If result is -ve it indicates there is absence of E-coli and hence absence of pathogens

c. Coliform/ E-coli test using membrane filter technique:

- It is the recently developed test with the use of membrane filter.
- The membrane filter consists of large number of microscopic pores which are capable of retaining bacteria.
- Procedure:
 1. The water is filtered through the membrane filter and the membrane is then placed on a sterilized pad absorbing nutrient (M-Endo's medium) which inhibits the growth of bacteria other than coliform group.
 2. It is then placed in an incubator at 37°C for a period of 20 hrs.
 3. If the coliform bacteria are present the colonies of coliform group bacteria can be seen through microscope.
- This test is takes less time, simple and can be performed in the field, precise so that even the densities less than 1 per 100 ml of sample can be detected.

Most probable number:

Most probable no (MPN) is defined as that bacterial density which is most likely to be present in water. It is given by:

$$\text{MPN per 100 ml of sample} = \frac{100 \times \text{no. of +ve test tubes}}{\sqrt{\text{ml in all portions} \times \text{ml in -ve portions}}}$$

For example considering fig 4.8, the four results are -ve and 1 is +ve for test tubes containing 10 ml of sample each.

The number of -ve portion = 1.

Total ml in all portions = $10 \times 5 = 50$ ml

and

Total ml in -ve portion = $10 \times 4 = 40$ ml.

then

$$\text{MPN} = \frac{100 \times 1}{\sqrt{50 \times 40}} = 2.24 \text{ numbers per 100 ml sample}$$

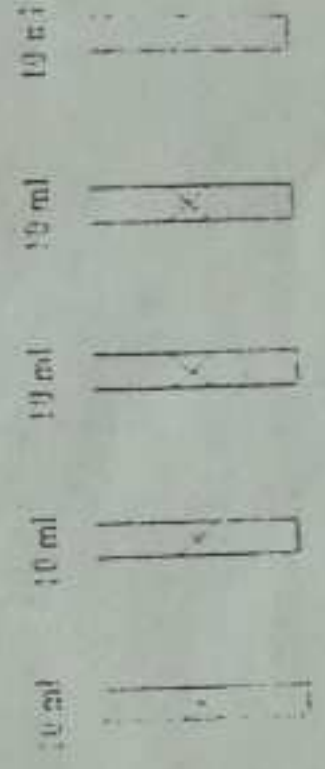

Fig 4.8 Results on test tubes

Water Supply Engineering

4.5 WATER QUALITY STANDARD

- Different for different purposes. Eg. For drinking purposes some chemical impurities is necessary but not for industrial purposes.
- Different organizations give different quality standard
 - ✓ World Health Organization (WHO)
 - ✓ Indian Council of Medical Research Committee (ICMRC)
 - ✓ United States Public Health Society (USPHS)
 - ✓ American Water Works Organization (AWWA)
 - ✓ Environmental Hygiene Committee (EHC)
- For ideal & safe public w/s the (WHO) standard is given in the table below

QUALITY STANDARD OF WATER (WHO STANDARD) (Source: Water Supply Engineering, Dr. B. C. Punmia & Jain)

Type	Impurity	Max. Permissible Limit in ppm or mg/l
1. Physical impurities	a. Colour (on cobalt scale) b. Turbidity (on silica scale) c. Taste & odour	a. 5 - 50 b. 5 - 25 c. Nil
2. Biological Impurities	Most Probable Number (MPN) of Coliform bacteria	Not more than 1 Coliform colony per 100 ml of water sample
3. Chemical Impurities	a. pH value b. Total solids (SS & DS) c. Hardness (equivalent to CaCO_3) d. Cadmium e. Chromium f. Selenium g. Arsenic h. Manganese i. Iron j. Lead k. Copper l. Zinc m. Fluoride n. Cyanide o. Phenolic substances (as Phenol) p. Sulphate q. BOD r. Nitrate s. Chloride	a. 7 - 8.5 b. 500 - 1500 c. 200 - 600 d. < 0.01 e. < 0.05 f. < 0.05 g. < 0.02 h. 0.1 - 1.5 i. 0.1 - 1 j. < 0.1 k. 1 - 1.5 l. 5 - 15 m. 0.5 - 1.5 n. < 0.01 o. 0.001 p. 200 - 400 q. ni r. 50 - 100 s. 200 - 600



5.1 DEFINITION AND FUNCTION OF INTAKE

- Before conveying water from source, collection of water by the construction of intake at the source is required.
- An intake is the device or structure placed in the water source ^{to draw water from source} and then discharge it into an intake conduit through which it flows (under gravity) to treatment plant or to intake well or direct supply and also from intake well it can be pumped to treatment plant or directly supplied.
- Hence the main function of intake is to help in safely withdrawing of water from the source over a predetermined range of pool level and discharge this into the withdrawal conduit, from which it can be flow under gravity or pumped to treatment plant or direct supply to the reservoir.

5.2 COMPONENTS OF INTAKE

- A intake consists of:

a. An intake conduit:

It is a conduit which conveys water to the treatment plant or reservoir or intake well. It further consists of:

- i. A fine screen at its inlet end for screening of small floating or suspended matters.
- ii. A valve to control the flow of water.

b. A structure:

- ✓ To permit the withdrawal of water from the source and for housing and supporting the intake conduit, valve operation device etc. a structure is required.
- ✓ The structure protects the conduit from being damaged or clogged by ice, trash, debris etc.
- ✓ An intake structure may be of a simple block supporting at the end of the conduit pipe to huge concrete towers which houses intake gates (to control flow), screens (for screening wooden logs, debris, trash, ice etc), pumps (for pumping) etc and even sometimes, living quarters and shop for operating personnel.
- ✓ The intake structure should be impermeable and designed to resist water pressure, forces due to wave, wind and floating debris etc.

* 5.3 FACTORS GOVERNING THE SITE SELECTION FOR INTAKE

1. Location should be near to the treatment plant so that cost of convey would be less.
2. Located in that place where quality of water is good and upstream of the sewage disposal point.

3. Should not be located near or in the navigation channel due to possibility of pollution caused by the discharge of refuse and wastes from ships and boats.
4. Located so as to ensure the supply even in worst condition. Deeper so that water is available also in dry period and cost of impounding dams or barrage is reduced.
5. Location should be such that future expansion is possible.
6. Easy access during floods and shouldn't be flooded.
7. Shouldn't locate on curve. If required locate it on the concave or outer bank because water is available in all times.
8. Located in such places which is less affected by scouring, silting and storm and location should be free from the attack of heavy water currents.
9. The site of the intake should be well connected by good approach roads.
10. Site should be stable and safe from wind currents, landslides etc.

5.4 CLASSIFICATION OF INTAKE

- For various water sources, different types of intakes are used.
- Intakes are classified in the following three basis:

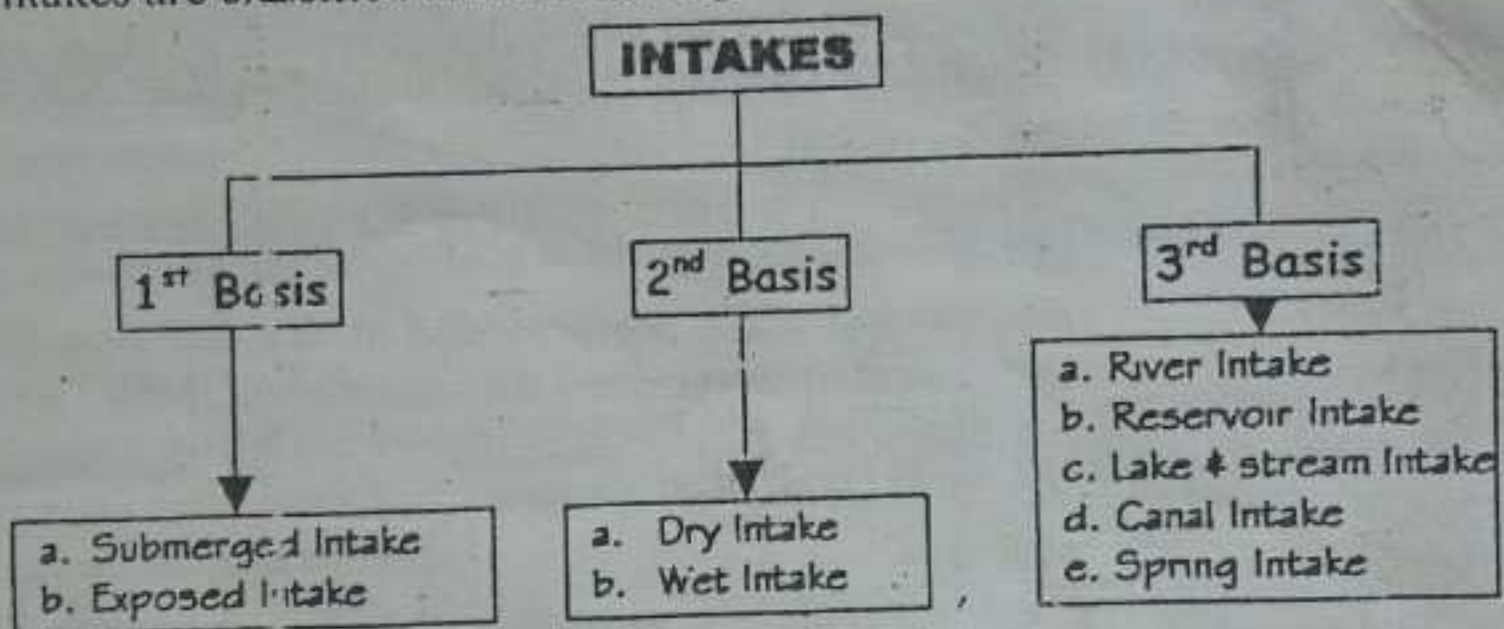

Fig. 5.1 Classification of Intakes

- **Submerged intake:** When an intake is constructed entirely under the water, this is called submerged intake. e.g. intake in lake.
- **Exposed intake:** When an intake is constructed near or away from bank of water bodies, this is called ~~submerged~~ ^{exposed} intake. e.g. intake in river
- **Wet intake:** It is an intake tower in which water level is practically remains as same as the level of the source of supply and water is conveyed indirectly passed into the convey pipes. There operation valves only in the inner shell. It are also called jack well.
- **Dry intake:** It is an intake tower in which no water remains in water tower and water through entry port is directly passed into the convey pipes but operation valves are used.
- The intake classified in the 3rd basis is described below.

5.5 RIVER INTAKE:

- ✓ A intake tower constructed at the bank or inside of the river to withdraw water is called river intake.
- ✓ As per their construction, river intake may be dry type or wet type.

a. Dry river intake:

- ✓ If gates are closed, there is no water inside the intake tower constructed at river and water through entry port is directly passed into the convey pipes then the intake is called dry river intake.
- ✓ Fig 5.2 shows a typical intake at the bank of river and fig 5.3 shows another typical intake constructed in the river.

- ✓ These intakes consist of circular or rectangular, masonry or RCC intake tower from where water can be withdrawal even in the dry period.

- ✓ Several inlets called penstocks for drawing water are provided at the different levels to permit the withdrawal of water when the water level drops.

- ✓ All inlet ends are provided with a screen (to prevent the entry of the floating matters) with valves to control the flow of water operation from the control room.

- ✓ The penstocks discharge the water into the intake tower

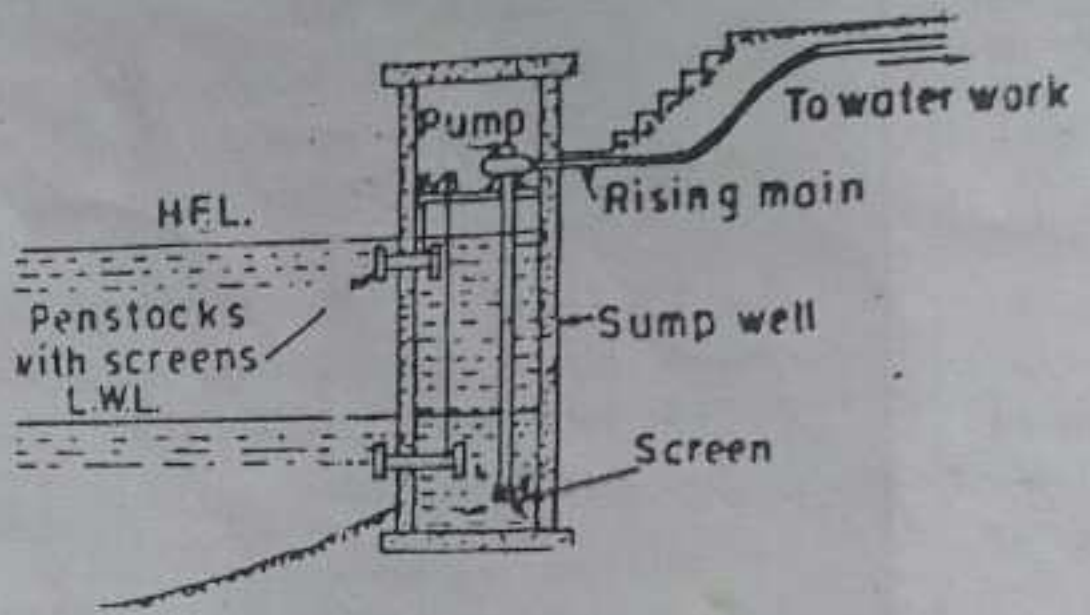

Fig 5.2 Typical river intake

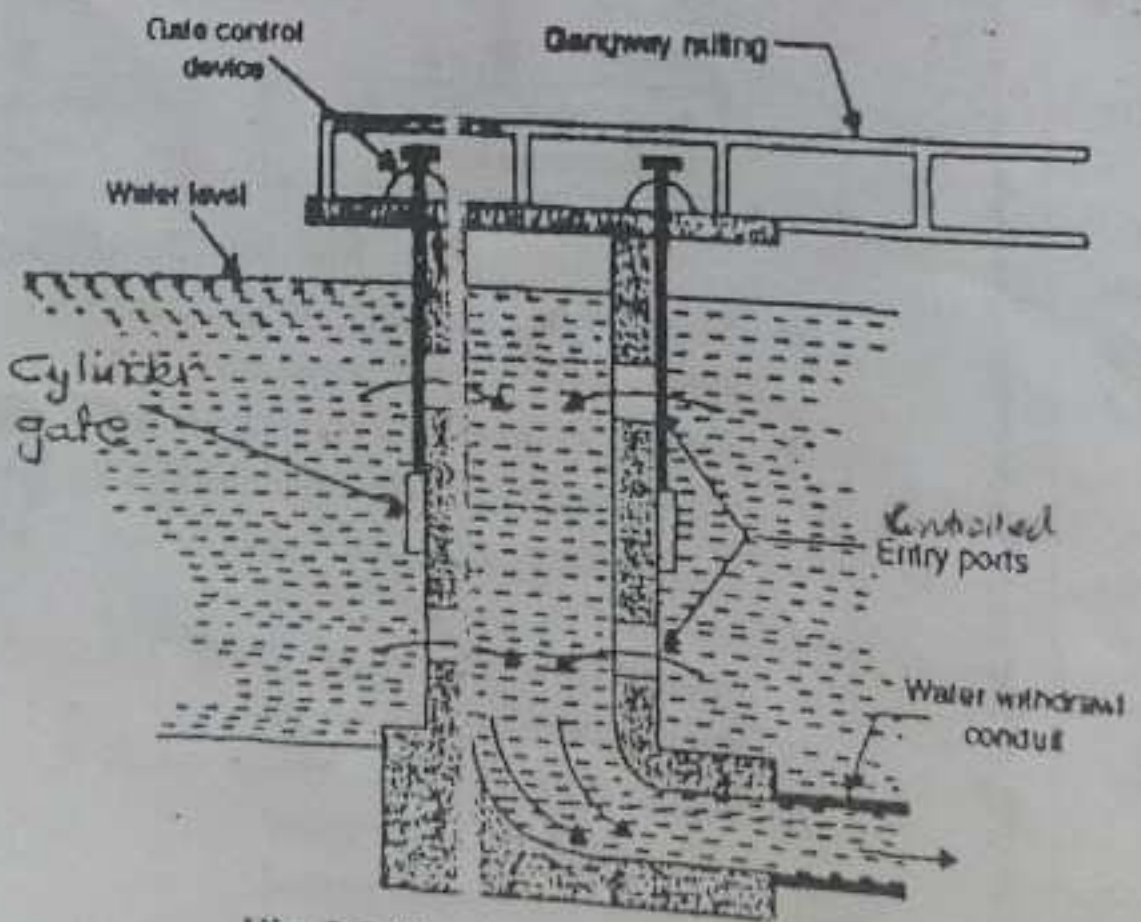

Fig 5.3 Typical dry river intake inside river

- ✓ (intake well) from where it is pumped or flow under gravity.
- ✓ In these cases, there will be no water inside the tower inlet valves are closed, so these are called dry intakes. Here inspection can be done by providing a ladder from control room.

b. Wet river intake:

- ✓ These intakes are normally constructed inside the river. Fig 5.4 shows a typical wet intake constructed in the river.
- ✓ In this case, there is water inside the intake tower, if the inlet valves of the tower are closed. Since these types of intakes remain wet, inspection cannot be done easily.

- ✓ It consists of inner and outer concrete shell. The wall of the outer shell consists of inlets (may be with screen) at different levels for withdrawal of water even in the dry period.

- ✓ Inner shell also consists of openings provided with gates (may be screen also) —

and a water withdrawal conduit to convey water under the gravity to the treatment plant directly or sump well at the bank, from where water can be pumped to treatment plant.

- ✓ Outer shell is always filled (wet) with water hence it is named as wet intake.

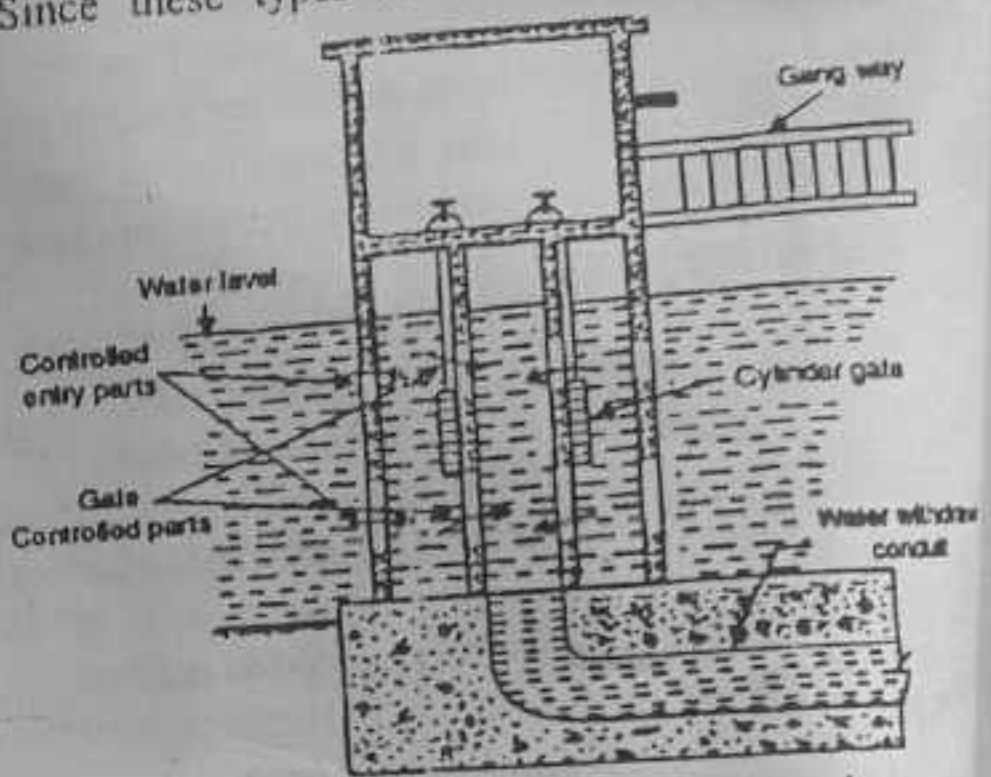

Fig 5.4 Typical wet river intake inside river

5.6 RESERVOIR INTAKE:

- There is a large variation in the discharge of river during monsoon and summer. When there is no sufficient water in the dry period the water in monsoon is collected in impounded reservoir by constructing weirs or dams across the river. The intake tower used in such cases is called reservoir intakes.

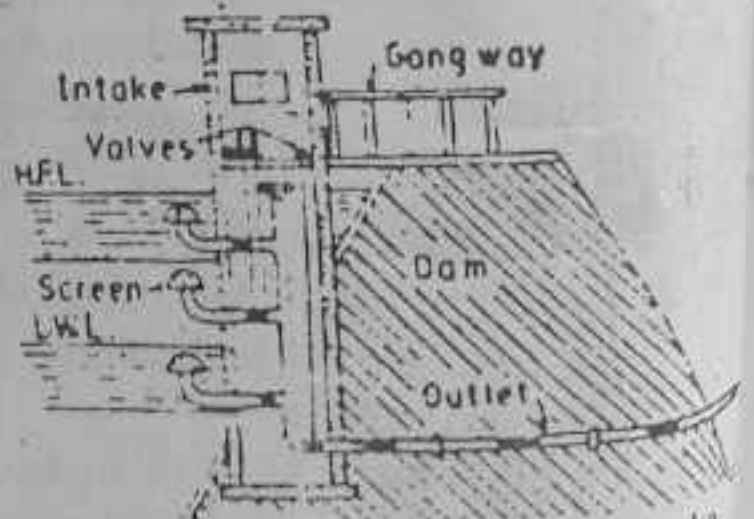

Fig 5.5 Typical reservoir intake at earthen dam

Two types of reservoir intakes are commonly used to suit the type of dam constructed. One type is at the slope of earthen dams (See fig 5.5) other type is within the dam itself in case of RCC dams (see fig 5.6).

In case of earthen dam, the intake may consist of an intake tower constructed on the upstream toe at dam from where intake can draw sufficient quantity of water even in the driest period.

The water is withdrawn through intake pipes located at different levels with a common vertical pipe so as to draw water in the driest period. The

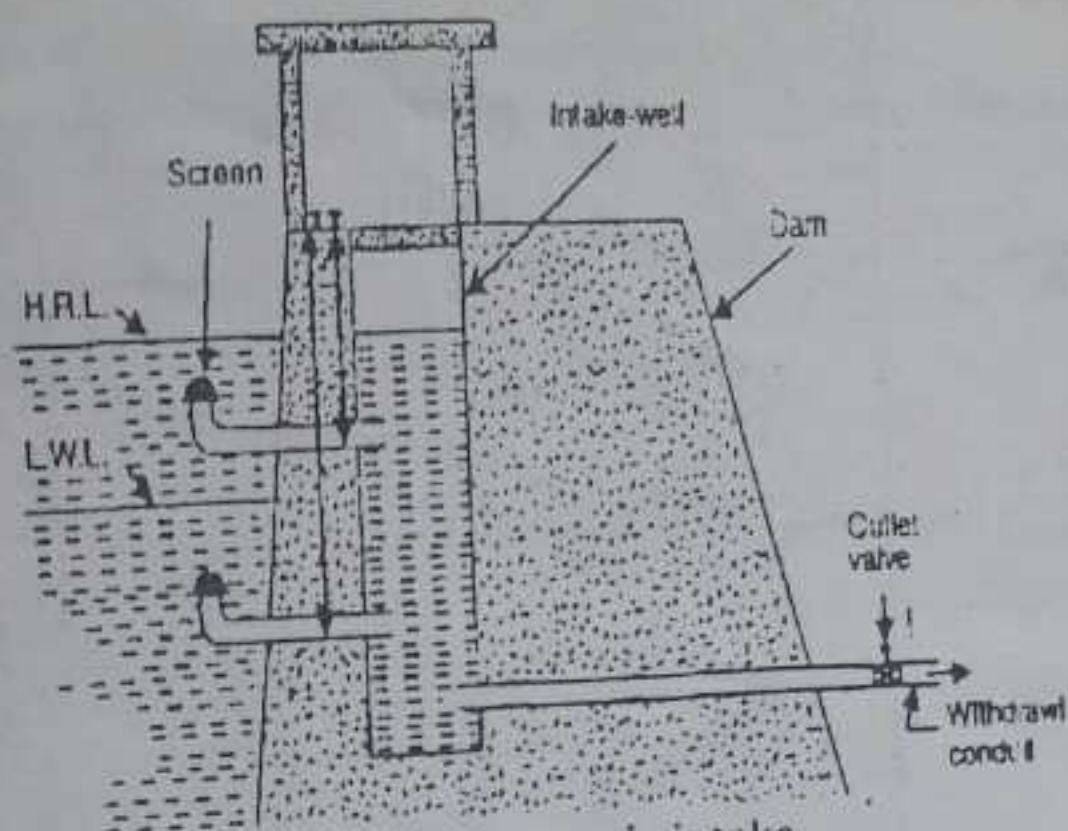

Fig 5.6 Typical reservoir intake within RCC dam itself

vertical pipe is connected at the bottom to an intake conduit which is taken out to through the body of dam.

Each inlet of intake pipes is covered with a hemispherical shaped screen to enter the relatively clear water. The intake pipe is provided with valves to control flow from control room.

When valves are open, the water enters to intake pipe and flow through common vertical pipe then conveyed to the treatment plant from outlet pipe. Since there is no water inside the tower (only in inlet pipes) this intake is called dry intake tower.

For inspection interior of the tower is accessible by a ladder provided from the control room which is connected to top of dam by a foot bridge.

In case of RCC masonry dams dry intake is constructed inside the dam itself and only porters or intake pipes are provided at various levels with control valves as shown in the fig 5.6.

5.7 LAKE AND STREAM INTAKE:

It is a submersible intake normally constructed at the central portion of the bed of lake for withdrawal of water because maximum depth of water is available at the central portion of natural lake. (See fig 5.7)

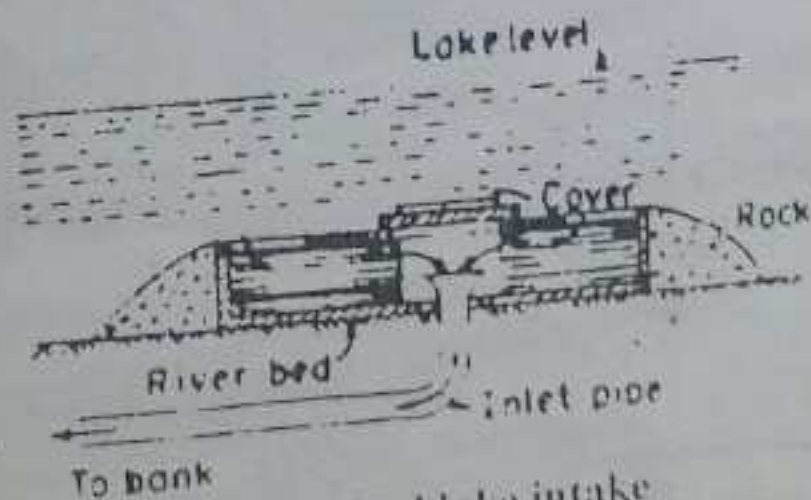

Fig 5.7 Typical lake intake

➤ Another type of similar intake constructed in the lake or stream at the place where it may not get buried under the silting due course of time used is shown in fig 5.8.

➤ It consists of an intake conduit laid on the bed of lake with its inlet end placed in the middle of the lake projecting above the bed.

➤ The inlet end of intake conduit is then covered by

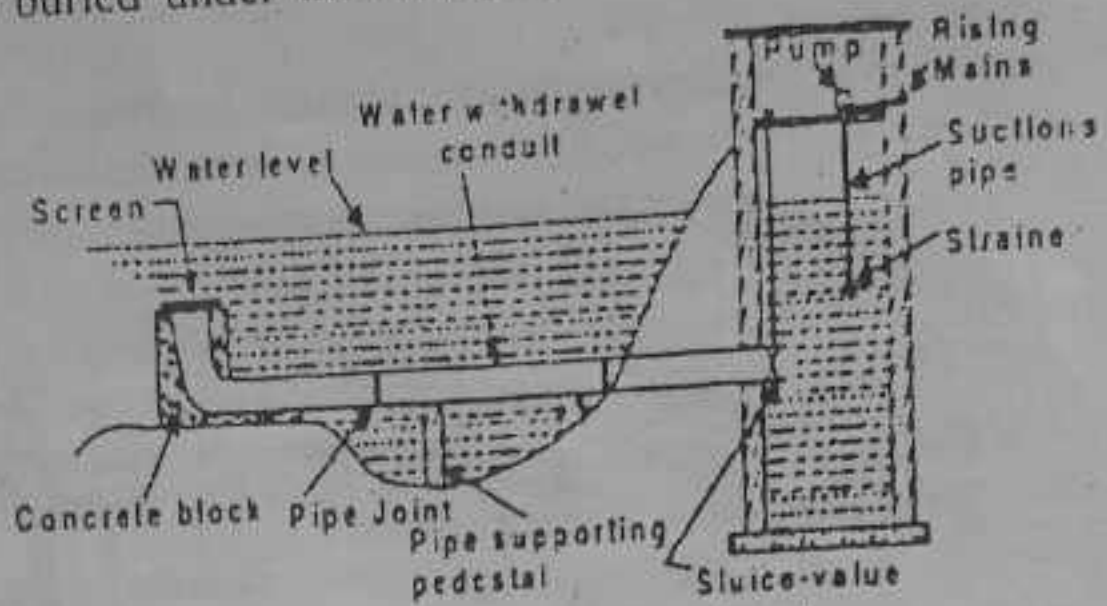

Fig 5.8 Typical stream and lake intake

protective timber or concrete crib. The water enters in the pipe through bell mouth (may be with screen) and flows under the gravity to treatment plant directly or to the sump well from where it can be pumped to treatment plant.

➤ More than one intake conduit can be used as per requirement.

➤ Since lake intake is submersible, there is no obstruction to the navigation, no danger from floating bodies, and no trouble due to ice and cheap in construction.

➤ It can draw small quantity of water and hence can be used in small water supply schemes whereas it is not easily accessible for maintenance.

5.8 CANAL INTAKE:

➤ Simple structure constructed on the bank and not necessary to provide porters at various level because water level in the canal remains more or less constant.

➤ It consists of a pipe placed in a brick masonry or RCC chamber constructed partly in the canal bank (See fig 5.9)

➤ On one side of the chamber an opening is provided with coarse screen to enter water. A

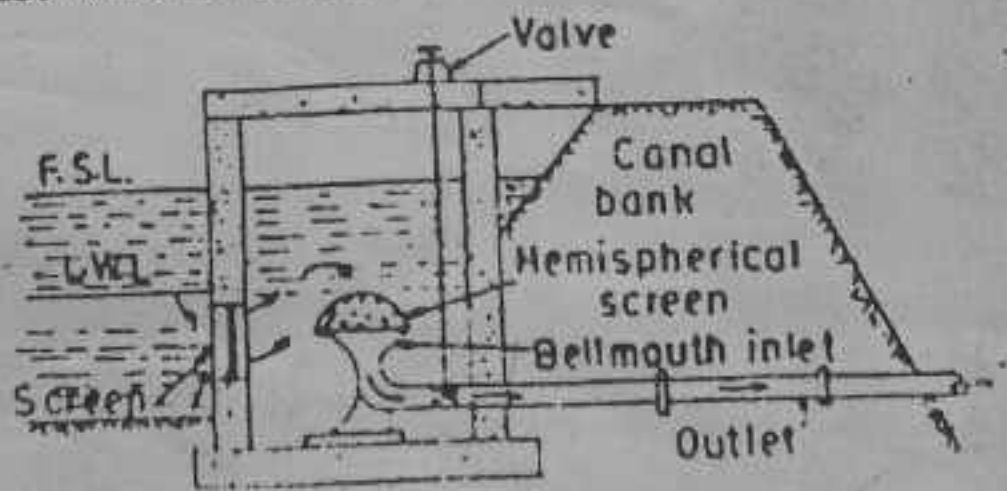

Fig 5.9 Typical canal intake

bell-mouth with hemispherical fine screen in the inlet end of the inlet pipe inside is provided and the outlet pipe is brought through the canal bank and taken to the treatment plant.

➤ One sluice valve operated by a wheel from the top of masonry chamber is provided to control flow in the inlet pipe.

5.9 SPRING INTAKE:

- An intake constructed at the spring source to withdraw water is called spring intake. It is generally constructed in small rural water supply scheme in Nepal.
- Spring intake should be impervious and provided around the source to prevent the source contamination and physical damage by runoff water.
- Simply one or more springs can be joined for greater discharge and all sources should be protected from animals, exposure, runoff and bathing etc. (See fig 5.10)
- Protection work is done by fencing, digging catch drain, bioengineering works etc.
- A typical spring intake used in rural water supply is shown in fig 5.11.

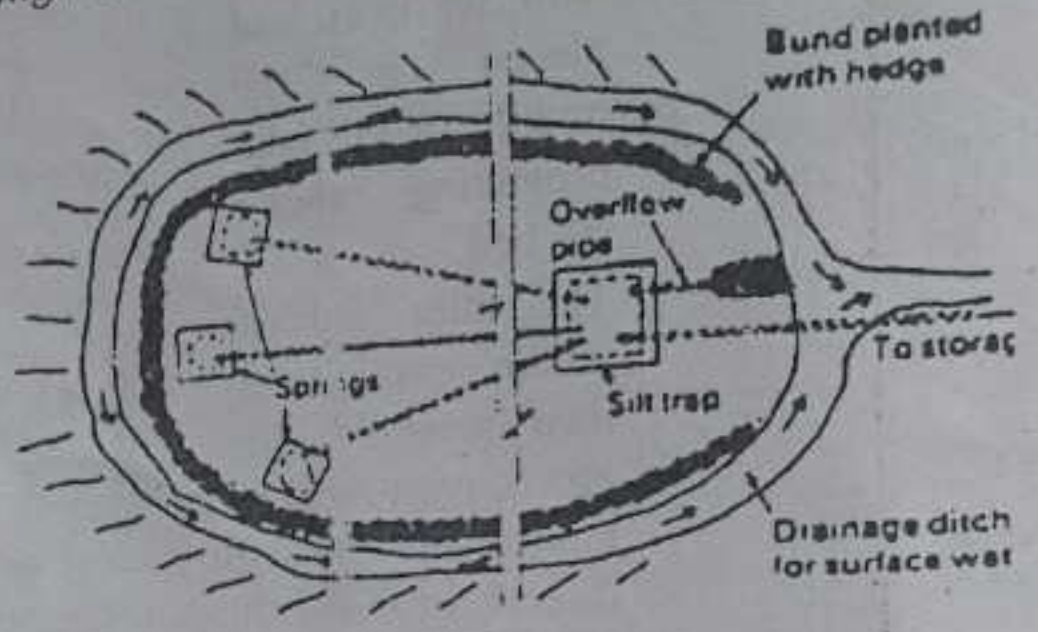

PLAN

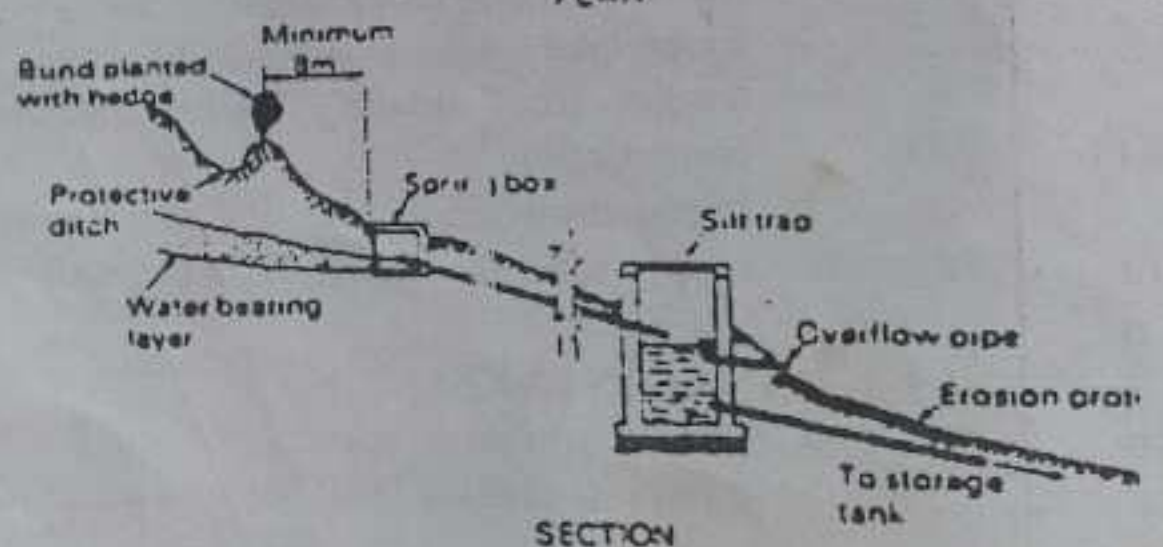

SECTION

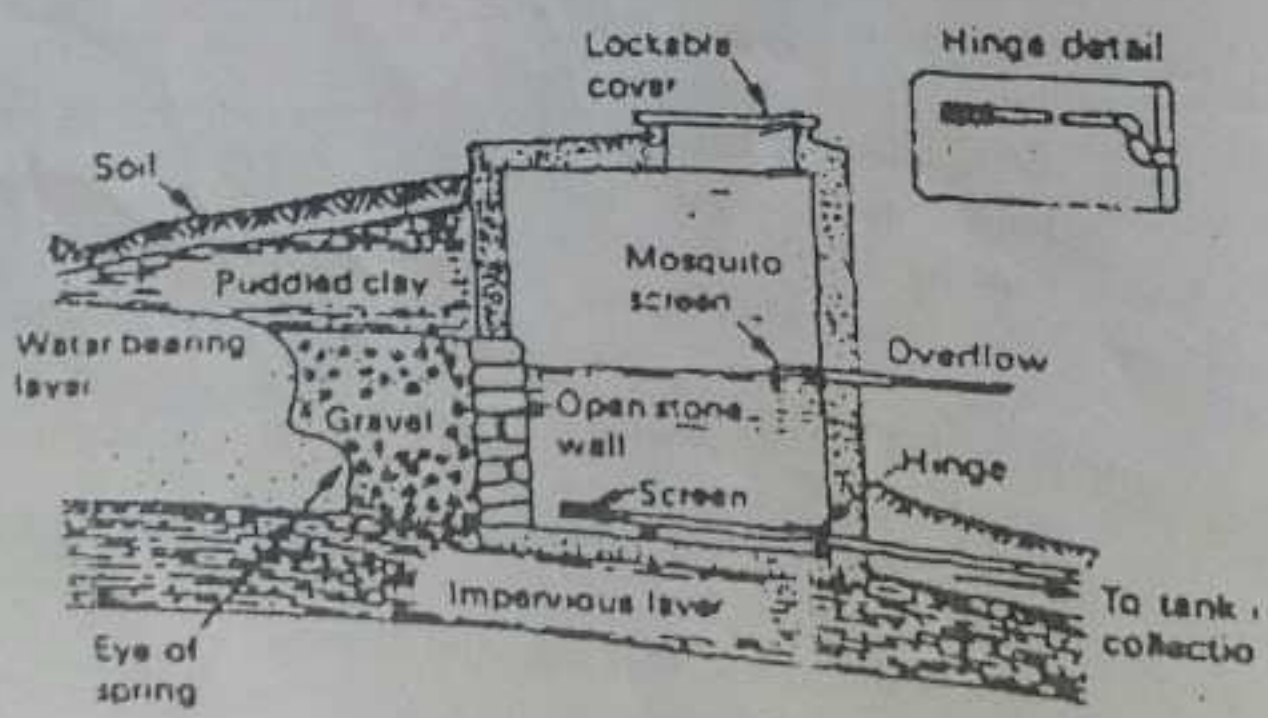

CHAPTER 6. WATER TREATMENT

6.1 INTRODUCTION

Water from any source may contain various suspended, colloidal and dissolved impurities which may be harmful or useful for drinking purposes. The removal of undesirable matters is called treatment. The degree of treatment depends upon quality of raw water and desired quality standard.

Various components are established in treatment plant with well equipped lab for test as per treatment requirement. Treatment plant should be located near the city at the safe point. The typical layout of the treatment plant is shown in the fig 6.1

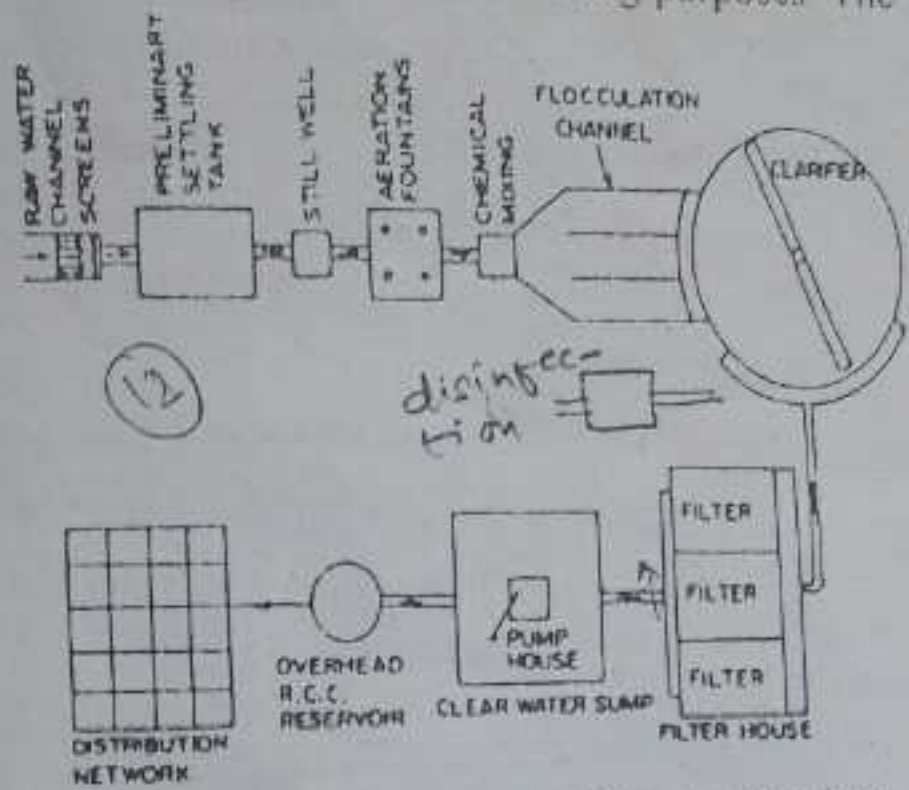

Fig 6.1 Schematic diagram of treatment plant

Various processes of treatment to remove various impurities are shown in the table 6.1 below

Table 6.1 Process of Water Treatment

S. No.	Process	Removal of
1	Screening	Large suspended and floating matters like leaves, fish, living organism, dead bodies, tree branches, bushes etc
2	Plain Sedimentation	Suspended matters, few colloidal and dissolved impurities (silt, sand, clay etc)
3	Sedimentation with Coagulation	Very fine suspended and colloidal impurities.
4	Filtration	Microorganisms, very fine suspended and colloidal impurities.
5	Aeration	Taste and odour, dissolved gases etc.
6	Disinfection	Pathogenic organisms by killing them.
7	Softening and Hardening	Hardness and softness
8	De-chlorination	Excessive chlorine
9	Miscellaneous	Iron, Manganese and other harmful constituents

6.2 OBJECTIVE OF TREATMENT

1. To reduce the impurities to a certain level that doesn't cause harm to human health.
2. To reduce the objectionable colour, odour, turbidity and hardness.
3. To kill pathogens harmful to human health.
4. To make water safe and potable for drinking.
5. To eliminate corrosive nature of water, affecting pipe.
6. To remove hardness of water.

6. To remove hardness of water suitable for a wide variety of purposes such as dyeing, steam generation etc.

6.3 SCREENING

The process followed by passing water through screens to remove large suspended matters like sticks, branches of tree, leaves, dead animal body, debris, pebbles, ice etc and other small suspended matters is called screening. The following two types of screens are generally used in screening.

a. Coarse screen:

Coarse screens are generally placed in front of the fine screens at the inlet to remove large suspended and floating matters, generally from surface sources. These screens are generally called trash racks or bar screen and consists of bar grills of 25 mm diameter. If openings are of 50 to 150 mm it is called as coarse screen and if 20 to 50 mm it is called medium screens. Mostly bar screens are kept inclined so that they can be cleaned easily with a rake. The slope may be 3 to 6 vertical to 1 horizontal. (See fig 6.2)

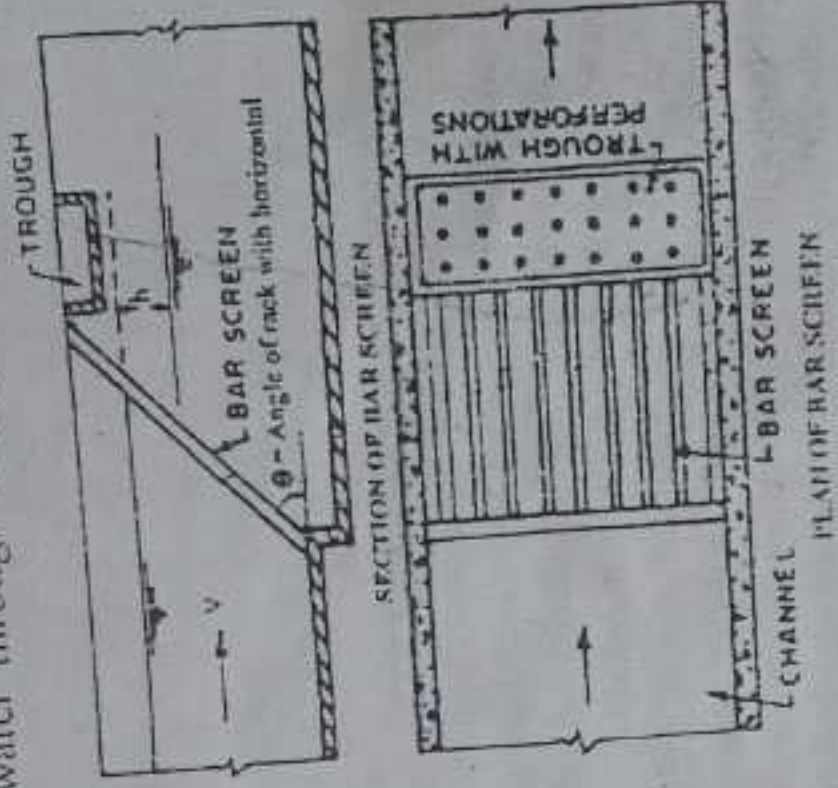

Fig 6.2 Coarse or bar screen (Trash rack)

b. Fine screen:

It is used to remove smaller suspended impurities at the surface of ground water intakes, sometimes alone or sometimes following a bar screen. It is generally used alone in the case of ground water intakes such as in springs intake (See fig 6.3). In case of surface intakes, fine screens are usually arranged with rotary drum perforated with holes of about 6 mm diameter and called rotary drum strainer. Microstrainer also can be used for this purpose

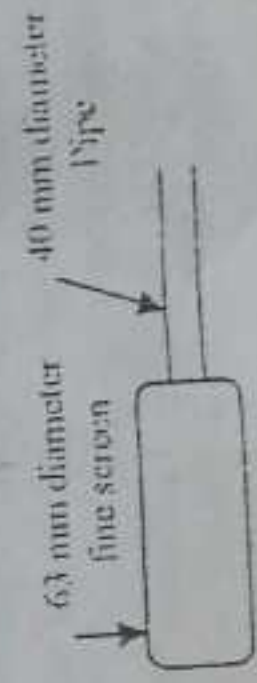

Fig 6.3 Fine screen

where some device is setup to clean continuously so that fine screens do not clogged up. Fine screens normally get clogged and are to be cleaned frequently. So they are avoided nowadays for surface intakes and fine particles are separated in sedimentation.

6.4 PLAIN SEDIMENTATION

It is the process in which water is retained in a tank or basin so that the suspended particles present in the water may be settle down under the action of gravity. The main purpose of plain sedimentation is to remove large amounts of suspended solids of present in raw water. Plain sedimentation is done after screening and before sedimentation with coagulation and located near the filter units and in case of variation of demand it can be used as the storage reservoirs. Water contains two types of suspended impurities:

- a. Inorganic solids having specific gravity 2.65 and 1
- b. Organic solids having specific gravity of 1 to 1.1.

Hence most of the suspended solids in water have specific gravity greater than 1 (i.e. specific gravity of water) and remains in suspension because of turbulence of flowing water but it can be removed by sedimentation.

6.5 THEORY OF SEDIMENTATION

The principle of sedimentation is that if water is retained in quiescent condition for certain period by reducing velocity, the particles will settle down due to gravitational forces then the sediments (called sludge) and floating matters (called scum) can be easily removed.

The retention tank or basin is called *sedimentation tank or sedimentation basin or settling basin or settling tank* and the time period for which water is retained in the tank is called *retention period or detention period or detention time or retention time*. Maximum retention period is taken as about 2 to 6 hrs.

The sedimentation is affected by velocity of flowing water, size, shape & specific gravity of particle; viscosity of water, detention time; effective depth & length of settling zone; inlet & outlet arrangements.

6.6 SETTLING VELOCITY OF DISCRETE PARTICLES

Any particle which does not change in shape, size and weight during rising and settling in any fluid is called discrete particle. If the specific gravity of the particle is more than the fluid, it will move vertically downwards due to the gravitational force. When a discrete particle is falling through a quiescent (non turbulence) fluid, it will accelerate (falling velocity increase) until the frictional resistance or drag becomes equal to gravitational force acting upon particle. The after this, the vertical velocity of settlement remains constant or uniform which is called settling velocity.

The impelling or driving force at the uniform velocity is equals to the effective weight of the particle in fluid. Mathematically,

Chapter 9. Valves and Fittings

$$F_i = (\gamma_s - \gamma) V = (\rho_s - \rho) gV \text{ or, } F_i = \pi \frac{d^3}{6} (\rho_s - \rho) g \text{-----(6.1)}$$

Where,
 F_i = Impelling or driving force, γ_s & γ is unit weights, ρ_s & ρ is mass density of particle and water respectively, g = acceleration due to gravity.

$$V = \text{volume of spherical particles of diameter } d' = \pi \frac{d^3}{6}$$

Again as per Newton's law or frictional resistance or drag, the drag force is:

$$F_d = C_d A \frac{\rho v_s^2}{2} \text{-----(6.2)}$$

Where,

C_d = Drag coefficient depends upon Reynold's number ' R_e ,'

A = projected area of the particle = $\pi d^2 / 4$ for spherical particle

At uniform settling velocity ' v_s ,' $F_i = F_d$, then from equation 6.1 & 6.2,

$$\pi \frac{d^3}{6} (\rho_s - \rho) g = C_d A \frac{\rho v_s^2}{2} \text{ or, } \pi \frac{d^3}{6} (\rho_s - \rho) g = C_d \frac{\pi d^2}{4} \frac{\rho v_s^2}{2}$$

$$\text{or, } v_s = \sqrt{\pi \frac{d^3}{6} (\rho_s - \rho) g \times \frac{8}{C_d \times \pi d^2 \times \rho}} = \sqrt{\frac{4}{3} \frac{gd (\rho_s - \rho)}{C_d \rho}}$$

Also we have, specific gravity of particle (S) = ρ_s / ρ , then,

$$\therefore v_s = \sqrt{\frac{4}{3} \frac{gd}{C_d} (S-1)} \text{-----(6.3)}$$

This is called Hazen's equation and applicable for particle diameter ' d ' > 0.1 to 1 mm and Reynold's number ' R_e ' > 1 to 1000. The nature of settling is neither laminar nor turbulent so the settling is called transition settling. Here,

$$C_d = \frac{24}{R_e} + \frac{3}{\sqrt{R_e}} + 0.34 \text{ and } R_e = \frac{\rho v_s d}{\mu}$$

Where, μ = absolute or

dynamic viscosity of water depends upon temperature = ρv ; v = Kinematic viscosity of water.

Table 6.2 Kinematic Viscosity ' v ' of Water

Temperature ' T ' (°C)	0	5	10	15	20	25	30
' v ' (centistokes or mm ² /sec)	1.792	1.519	1.308	1.141	1.007	0.897	0.804

Hazen further indicated that for particles having diameter ' d ' ≤ 0.1 mm and Reynold's number ' R_e ' ≤ 1 , Stoke's law is applicable. Mathematically,

$$F_d = 3\pi\mu v_s d \text{ -----(6.4)}$$

Now, from equation 6.2 & 6.4,

$$3\pi\mu v_s d = C_d A \frac{\rho v_s^2}{2} \text{ \& putting } A = \frac{\pi d^2}{4}, \text{ we get,}$$

$$C_d = \frac{24}{\rho v_s d / \mu} \Rightarrow C_d = \frac{24}{R_e}$$

Now putting this value in equation 6.3 we get, $v_s = \sqrt{\frac{4}{3} \frac{gd}{(24/R_e)} (S-1)}$

or, $v_s^2 = \frac{gd}{18} R_e (S-1)$ or, $v_s^2 = \frac{gd}{18} \frac{\rho v_s d}{\mu} (S-1)$ or,

$$v_s = \frac{g d^2}{18 (\mu/\rho)} (S-1) \Rightarrow v_s = \frac{g d^2}{18 \nu} (S-1) \text{ This is Stoke's equation}$$

where, $\frac{\mu}{\rho} = \nu$ = Kinematic viscosity of water depends on temperature.

Alternatively if temperature of water ' T ' in $^{\circ}C$ is introduced in place of ν in

above formula, it can be expressed as, $v_s = 418 (S-1) d^2 \frac{(3T+70)}{100}$

These equations are valid for $d \leq 0.1$ mm and $R_e \leq 1$. In this range settling of particle is laminar so it is termed as laminar settling of particles.

If the nature of settling of particle is turbulent, (ie $1000 < R_e \leq 10000$) and ' d ' > 1 mm the value of $C_d \approx 0.4$ then Hazen's equation becomes,

$$v_s^2 = \frac{(4/3)gd(S-1)d}{3 \times 0.4} \Rightarrow v_s = \sqrt{3.33gd(S-1)}$$

This equation is called

Newton's equation

6.7 TYPES OF SEDIMENTATION TANKS

Sedimentation tanks are generally made of RCC and may be rectangular and circular in shape. According to the method of function or operation they are classified into two

1. Quiescent or fill and draw type

2. Continuous flow type

1. Quiescent or fill and draw type:

This tank is normally rectangular in plan (See fig 6.4). The water is first filled and then allowed for some retention period of 30 to 60 hrs (normally 24 hrs) for sedimentation of particles. The clear water is drawn from outlet and tank is then made empty and cleaning of sediment is done. After cleaning, again the filling and emptying process is similarly repeated.

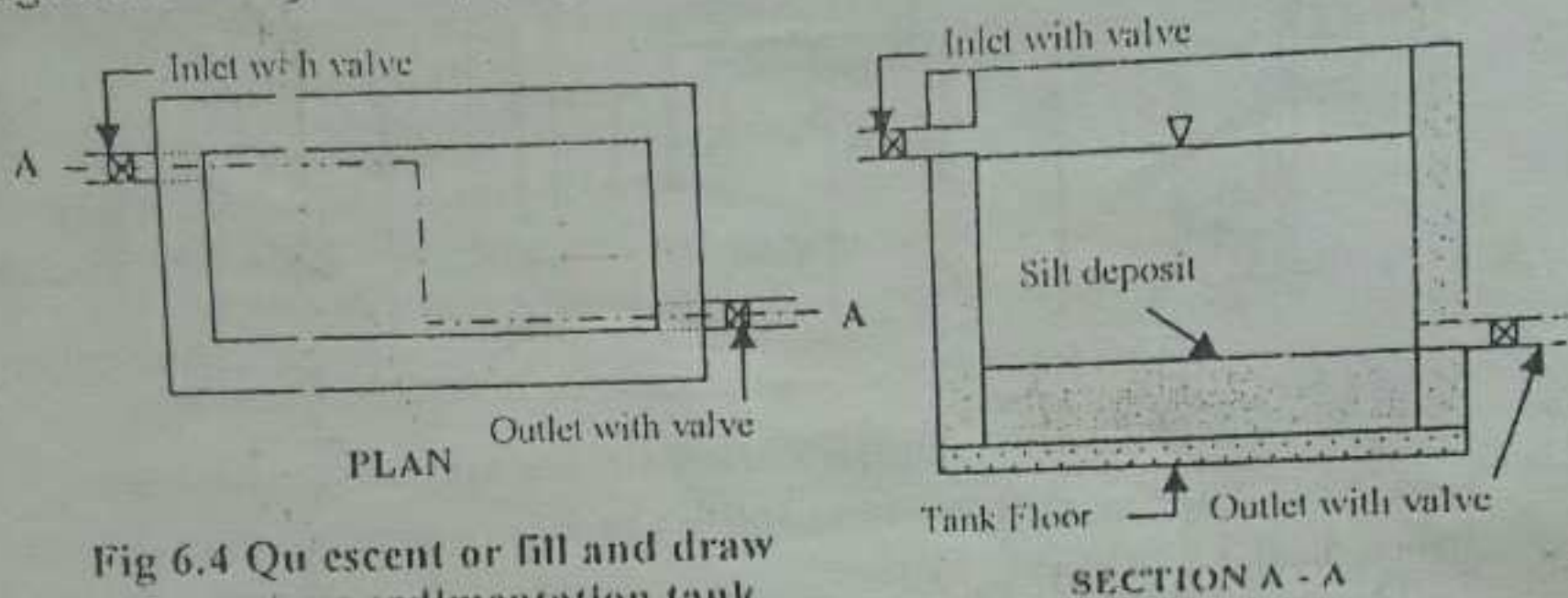

Fig 6.4 Quiescent or fill and draw type sedimentation tank

These tanks need more detention period, more labours and supervision, more than one tanks are required and head loss is high hence it is not used nowadays.

2. Continuous flow type:

In this type of tank, raw water admits continuously through inlet and allowed to flow slowly in the tank for continuous settlement. Clearing and clear water is continuously flows out through outlet. These tanks work in the principle that by reducing the velocity of flow of water, large amount of particles present in water can be made settle down.

The velocity of flow of water in these tanks is reduced by providing sufficient length of travel for water in the tank. Further the velocity of flow of water in these tanks is so adjusted that the time taken by particle of water to move from inlet to outlet is slightly more than that required for settling of a suspended particle in water. Continuous flow type sedimentation tanks may be rectangular, square and circular in shape. According to flow direction these tanks may be classified into following:

- A Horizontal Flow type
- B Vertical Flow Type

A. Horizontal Flow Type

In these tanks the direction of flow of water is horizontal and they are further classified into following

- (a) Rectangular tanks with longitudinal flow
- (b) Circular with radial flow
- (c) Dorr clarifier

a. Rectangular tanks with longitudinal flow:

These tanks may be provided with baffles or without baffles and the flow is longitudinal. Fig 6.5 shows the rectangular continuous sedimentation tanks with baffles. These tanks consist of an inlet and an outlet channel and a sloping floor (1% for mechanized and 10% for manual) to collect sludge. The sludge is taken out through sludge outlet under hydrostatic pressure.

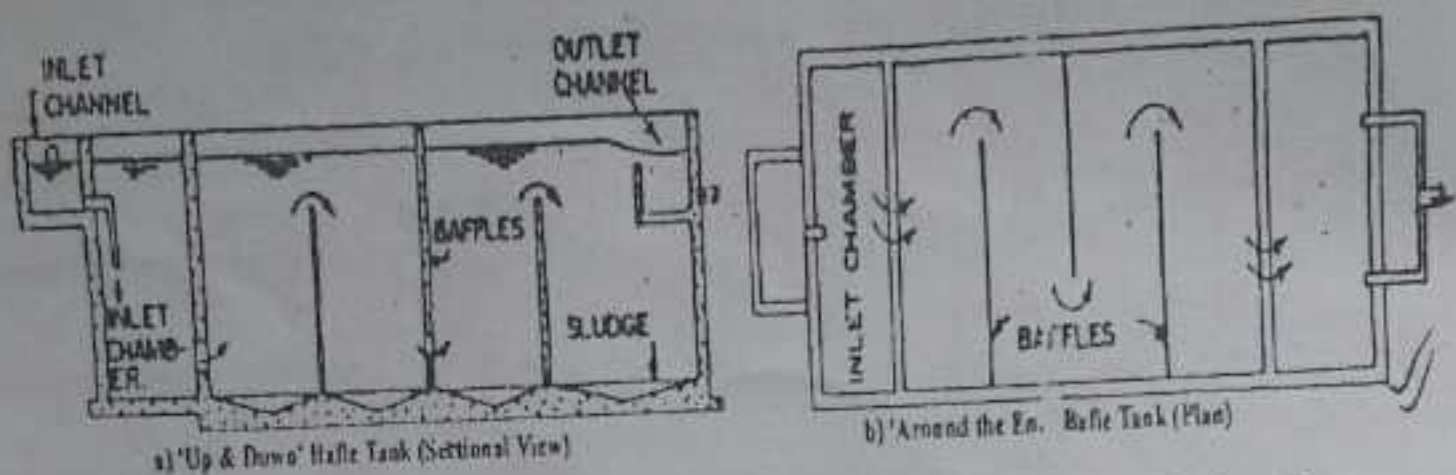

Fig 6.5 Rectangular sedimentation tank (ST) with baffles

The length (L) is 30 to 100 m (30 m is common), width (B) is of 12 m and L: B is 3:1 to 5:1 and a effective depth of 2.5 to 5 m (3 m is common) with 1m sludge depth and 0.3 to 0.5 m of free board is provided for these tanks. Tanks without baffles but with scraping mechanism are common (See fig 6.6).

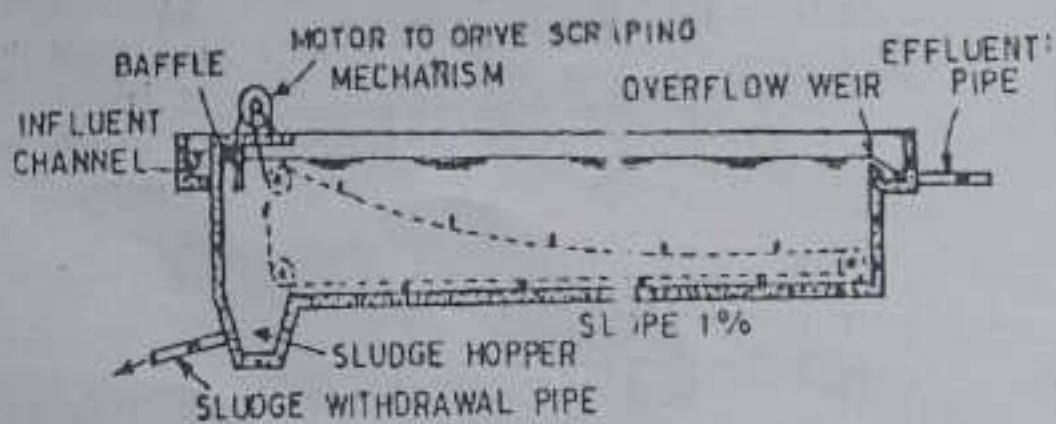

Fig 6.6 Rectangular continuous ST with scraping mechanism

b. Circular with radial flow:

These are normally used in sedimentation and may be up to 30 to 60 m in diameter (commonly 30 m to reduce wind effect) and floors are provided with a slope of 1V: 12H from periphery towards center. On the basis of flow these circular continuous types of tanks are classified into two:

- (i) Circular with central feed and (ii) Circular with peripheral feed

i. Circular with central feed:

In circular tank with central feed, water enters the tank at the center and leaves at its periphery (See fig 6.7). The most common is circular tank with central feed type.

Flowing Area

plan

ii. Circular with peripheral feed:

In circular tank with peripheral feed, water enters the tank from draw off channel.

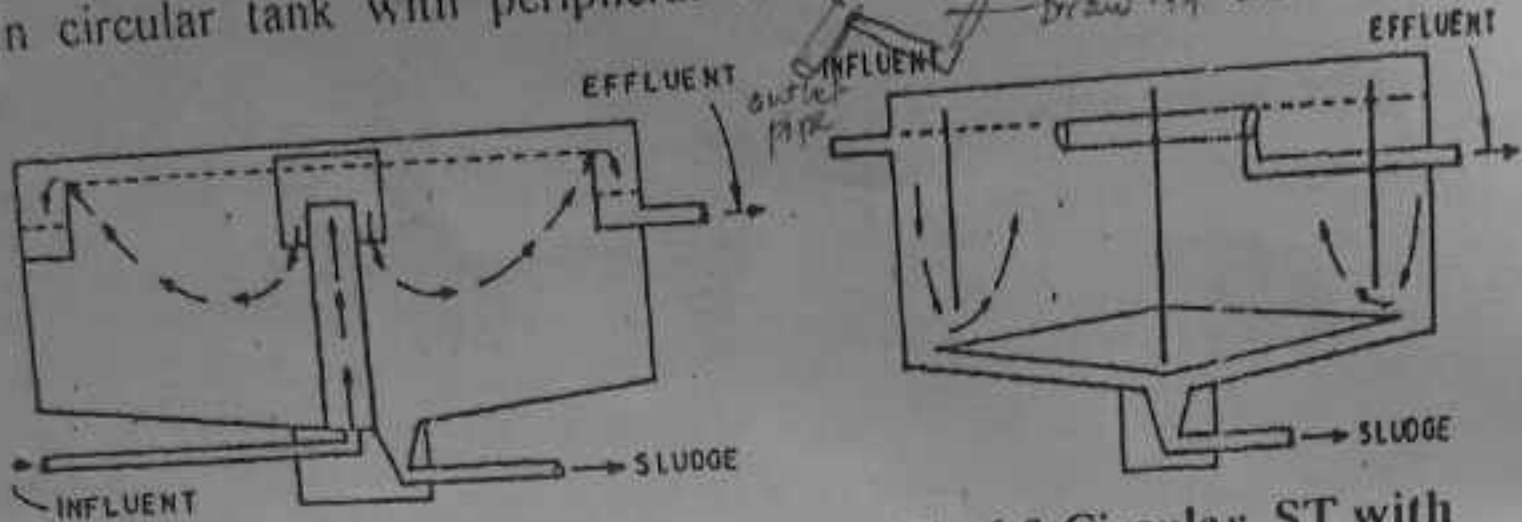

Fig 6.7 Circular ST with central feed

Fig 6.8 Circular ST with peripheral feed

periphery and leaves at the center. (See fig 6.8). It is not common.

iii. Dorr clarifier:

This is the well known circular continuous flow type sedimentation tank with central feed and shown in fig 6.9. The raw water enters continuously through a central vertical inlet pipe and emanates from multiple ports of diffuser provided at inlet top and water flows radially outward in all direction equally. A circular baffle wall is provided to reduce the velocity of incoming water. The clear water is collected into an effluent channel after sedimentation and finally into outlet pipes.

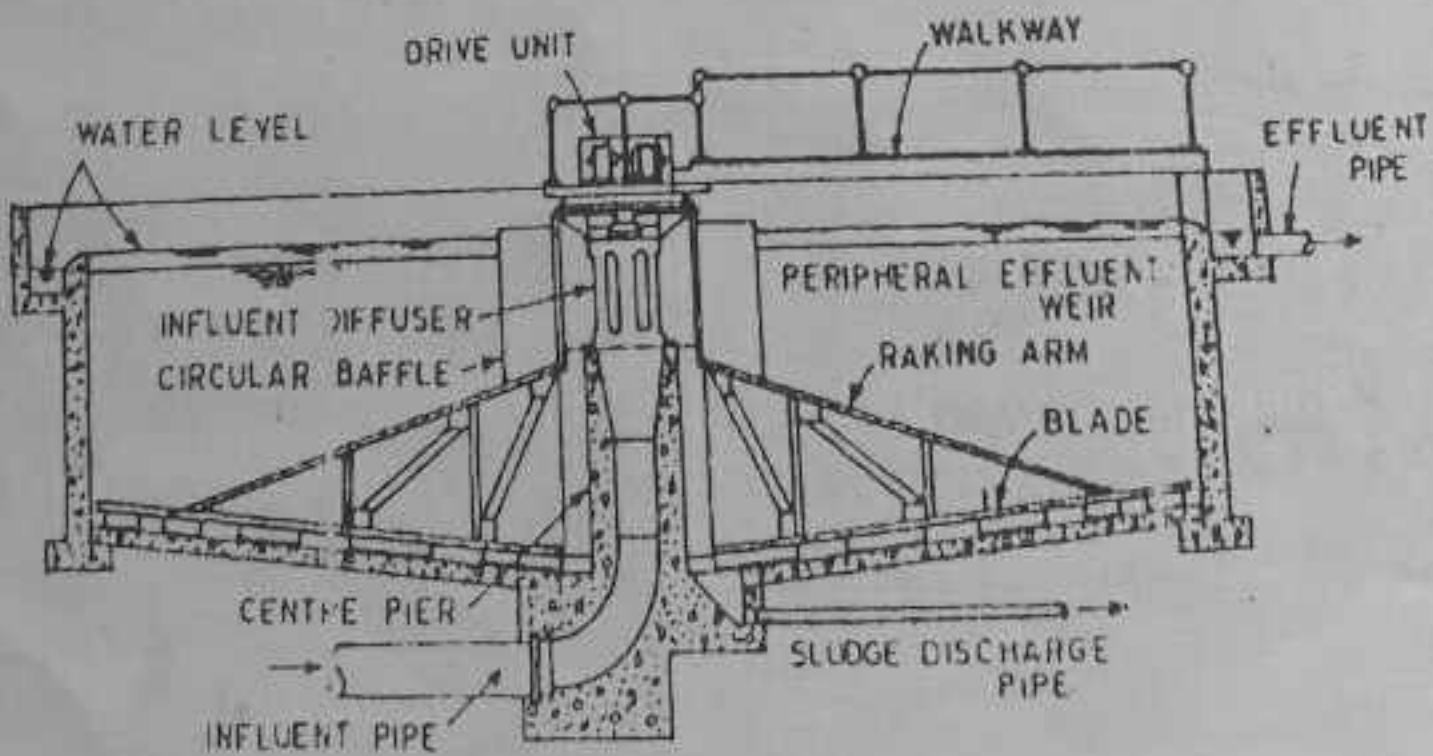

Fig 6.9 Dorr clarifier

The sludge or settled matter deposited at the bottom of the tank is continuously removed by a sludge removal mechanism (i.e. collector arm).

B. Vertical Flow Type

These tanks may be square or circular in shape at the top and have hopper bottom as shown in fig 6.10. So it is also called hopper bottom tank. The flow of water in this tank is vertical. Water enters to the tank through centrally placed pipe and by the action of deflector box it travels vertically downwards.

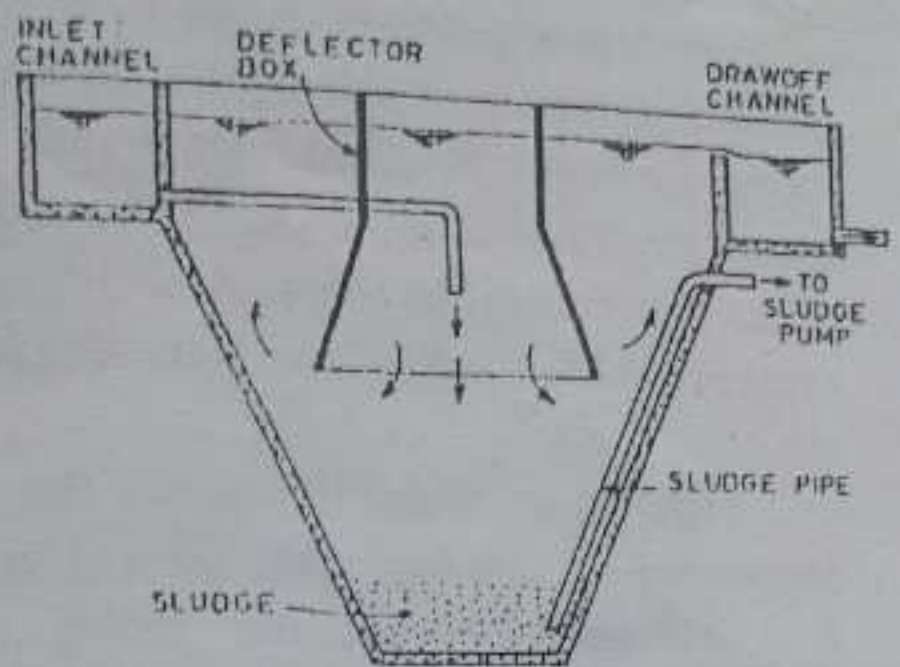

Fig 6.10 Hopper bottom tank with vertical flow

The sludge is collected at the bottom and removed from the sludge pipe with pump. The clear water flows out through a circumferential weir discharging into the draw off channel.

6.8 DESIGN OF HORIZONTAL FLOW SEDIMENTATION TANK

Design of sedimentation tank needs the following: (See fig 6.11)

(a) *Inlet zone with appropriate inlet structure*

Suitable inlet structure should be designed. It is kept at the half way between the surface & the floor of the tank and mid of the width of the water depth. The length of the inlet zone (l_i) is taken as $0.2 - 1m$ according to velocity.

(b) *Outlet zone with appropriate inlet structure*

Suitable outlet structure should be designed. It is kept just near the water surface. The length of the outlet zone (l_o) is taken as $0.2 - 1m$ according to velocity.

(c) *Sludge zone*

The zone in the bottom of the tank in which sludge is retained before removal is called sludge zone. The depth of the sludge zone depends upon the quantity of sediments in the raw water and the de-sludging period. Depth of sludge zone (d_s) is taken as $0.5 - 1.5 m$. (generally $1m$)

(d) *Free board*

The free space left on the top of the water level on the tank is called free board (FB) and in design FB is taken as $0.1 - 1 m$ (generally $0.3 - 0.5 m$).

(e) *Others such as Baffles, Washout/drain, Overflow etc.*

Baffle walls are provided to improve L/B ratio without increasing tank size. Washout is provided at the bottom of the sloped portion for drain at cleaning. Overflow is provided just below from the inlet in suitable side for overflow.

(f) *Settling zone or effective zone*

Actual settlement is occurs in this zone. Hence effective dimensions [effective length (l), width (B) and effective depth (d)] of this zone is very important in design.

Surface loading or surface overflow rate (SOR) of sedimentation tank:
 Let us consider an ideal rectangular horizontal flow sedimentation tank as shown in the fig 6.11 with following parameters.

- Q = Discharge (in and out); l_i = Length of inlet zone; l_o = Length of outlet zone;
- l = Effective length or length of settling zone; B = Width of tank;
- FB = Free board; d = Effective depth or depth of settling zone;
- d_s = Depth of sludge zone; v_h = Horizontal velocity;
- v_s = Settling velocity of particle; v = Resultant velocity
- So, L = Overall length of ST = $l_i + l + l_o$; D = Overall depth of ST = FB + d + d_s

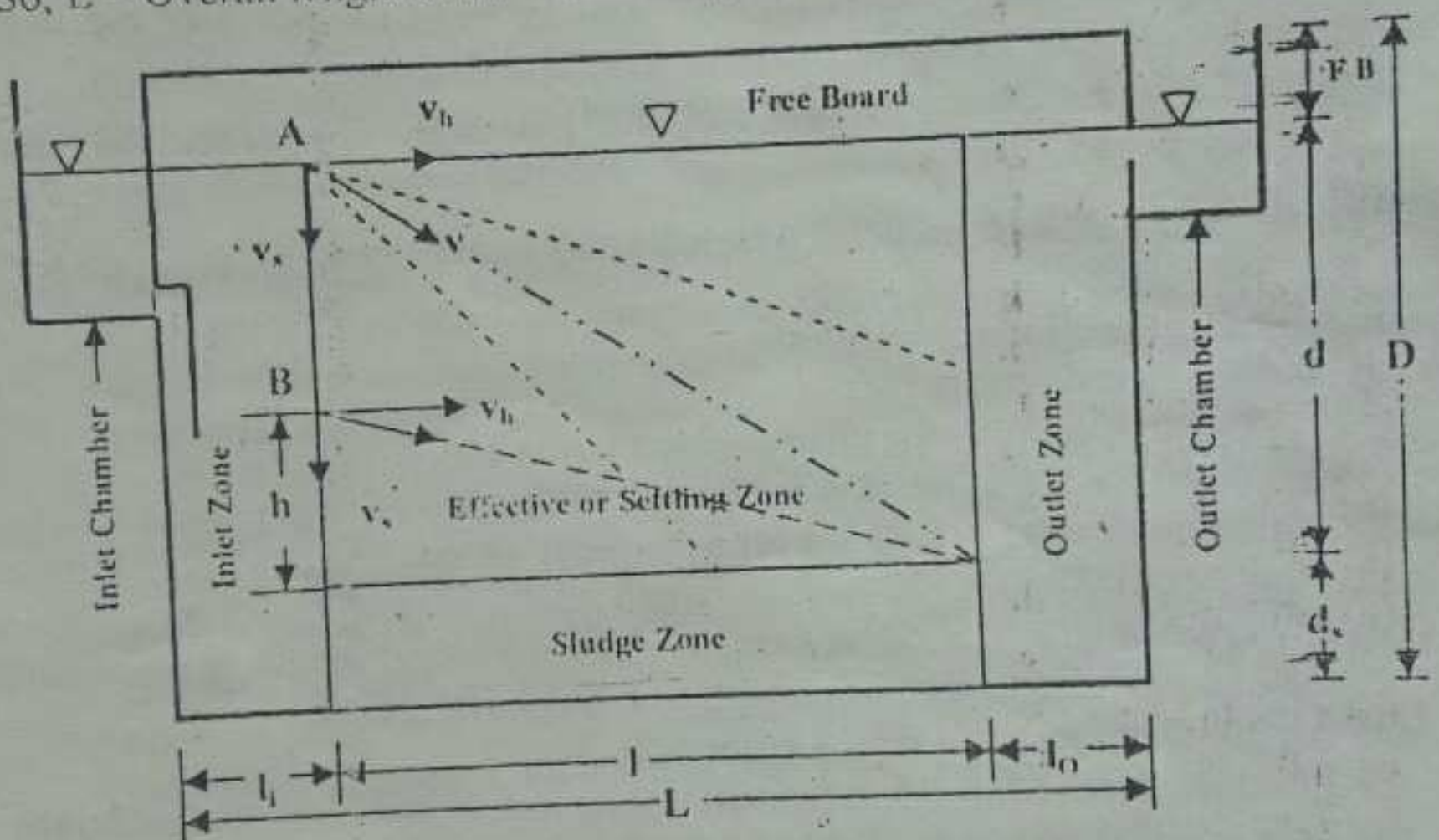

Fig 6.11 An ideal horizontal flow rectangular sedimentation tank

Within the settling zone, it is assumed that sediments are uniformly distributed throughout the tank where water enters the tank at the uniform velocity v_h ($v_h \rightarrow 0 \neq 0$ or quiescent condition). The path of discrete particle is given by the vector sum of the flow velocity v_h and settling velocity v_s and responsible for effective dimension of tank.

We have, $v_h = \frac{l}{t}$ and $v_s = \frac{d}{t}$, then, $\frac{v_h}{v_s} = \frac{l}{t} \times \frac{t}{d} = \frac{l}{d}$

or, $v_s = v_h \times \frac{d}{l} = \frac{Q}{A_h} \times \frac{d}{l} = \frac{Q}{Bd} \times \frac{d}{l} = \frac{Q}{Bl} = \frac{Q}{A_s}$

Where,

v_s is called surface overflow rate (SOR) of the sedimentation tank and all particles having SOR i.e. $v_s \geq \frac{Q}{Bl}$ will settle down and will be removed,

A_n = effective sectional area of tank perpendicular to the horizontal flow = Bd ,

A_s = effective surface area of tank = Bl ,

Removal efficiency of sedimentation tank:

Let v_s is the settling velocity of smaller particle less than SOR (i.e. $v_s < (Q/Bl)$) and if out of x_0 particles, x particles settle down and are removed, the ratio of removal of this particles (x/x_0) is called the removal efficiency of sedimentation tank for discrete particles of same size and is given

by, $\left(\frac{x}{x_0}\right) = \left(\frac{v_s}{Q/Bl}\right)$ Where, (Q/Bl) is SOR represents the settling velocity of the slowest particles which are 100% removed.

Design criteria of sedimentation tank:

- Surface overflow rate (SOR):
= 15 – 30 $m^3/m^2/day$ for Plain Sedimentation and
= 30 – 40 (or 50) $m^3/m^2/day$ for Sedimentation with Coagulation,
- Detention time (t) = 1 – 3 hrs (or sometimes up to 6 hrs)
- Flow velocity (v_h) = 150 – 300 mm/min
- Effective length (l) \leq 50 m (usually \leq 30 m) and if length is more baffles may be provided to increase length and Width (B) \leq 12 m
- Length width ratio (l/B) \leq 5 (generally, 3 – 5)
- Effective depth (d) \leq 3.5 m (sometimes up to 6 m including sludge depth)
- Free Board (FB) = 0.1 – 1 m but 0.3 – 0.5 m generally
- Depth of sludge zone (d_s) = generally 1 m.
- For Circular tank, diameter (ϕ) \leq 60 m (usually 30 – 60 m)
- Effective volume (V_e):
= $l \times B \times d$ for rectangular sedimentation tank and
= $\phi^2(0.11\phi + 0.785d)$ for circular sedimentation tank.

6.9 SEDIMENTATION WITH COAGULATION

The efficiency of plain sedimentation is generally very low especially when raw water contains very fine suspended particles of clay, silt and light colloidal matter which do not settle down in plain sedimentation in a reasonable detention period. The settling down and removal of such fine suspended

particles and colloidal matter can be achieved by chemically assisted sedimentation called Sedimentation with Coagulation.

The chemicals added are called coagulants, the formed insoluble gelatinous precipitate is called floc, the process of adding coagulants to raw water and mixing it thoroughly is known as coagulation and the process of formation of floc is called flocculation. If the content of suspended solids in raw water is greater than 50 mg/l, the sedimentation with coagulation is used to effect more complete removal of the suspended matters. The chemical use also removes colour, odour and taste. Properly applied coagulants are harmless to the consumers.

The theory is that the ions of floc are + ve charge and attract - ve charged suspended particles of clay, silt and colloidal matter present in water thus the floc becomes heavier and settles down which is further removed by sedimentation. Sedimentation with coagulation is not the complete method of treatment but it is the preliminary step in the preparation of water for filtration.

6.10 CHEMICALS USED AS COAGULANTS

The following chemicals are used as coagulants:

1. Aluminum sulphates or alum
2. Iron salts
3. Chlorinated copperas
4. Sodium aluminate

The dose of coagulants depends upon the Turbidity, colour, pH temperature and the time of the settlement.

1. Aluminum sulphates or alum $[Al_2(SO_4)_3 \cdot 18 H_2O]$:

It is the commonly used coagulants for coagulation in water in which alum is added and for alum water shall contain some alkalinity.

If bicarbonate alkalinity is present in water the floc formation is given by,

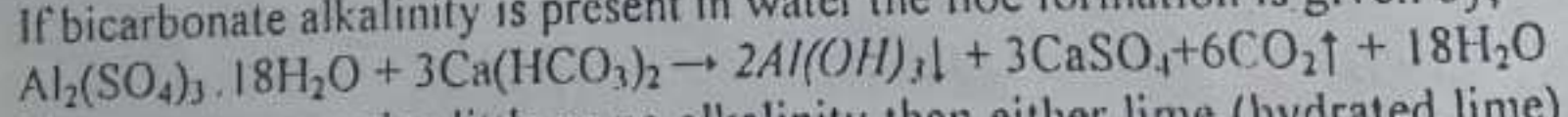

If raw water contains little or no alkalinity then either lime (hydrated lime) or soda ash is added for alkalinity. Then,

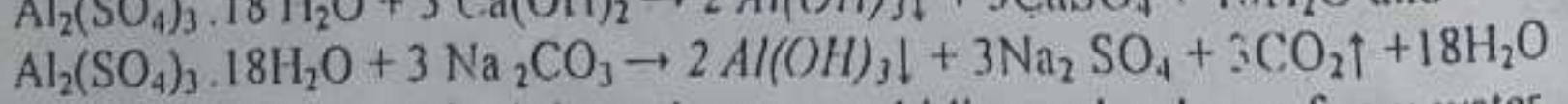
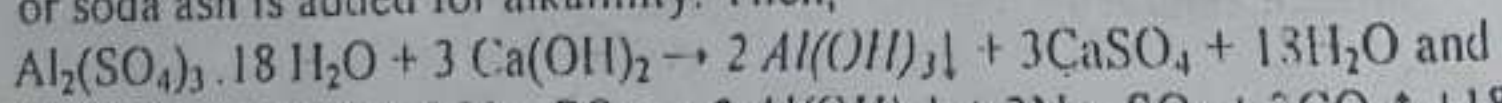

Amount of alum required depends upon turbidity and colour of raw water. Usual dose is 5 mg/l for relatively clear water to 30 mg/l for high turbid water. Average dose for normal water is 14 mg/l but amount to be added is determined by jar test which is discussed in lab.

Advantages:

1. It forms excellent floc better than that form by any other coagulant.
2. The floc formed is stable and not broken easily.
3. It is relatively cheap and removes colour, odour and taste.
4. It doesn't require skilled supervision and produces clear and crystal free water.

Disadvantages:

1. It requires alkalinity ranging pH from 6.5 to 8.5 in water for effective use.
2. The product calcium sulphates may cause permanent hardness and CO₂ may cause corrosion.
3. Difficult to dewater the heavy sludge formed because it is not suitable for filling in the low levels.

2. Iron salts:

The various iron salts used as coagulants are *ferrous sulphates, Ferric sulphates and ferric chloride*.

(a) *Ferrous sulphates [FeSO₄. 7H₂O]:*

It is also known as copperas used as coagulants in conjunction with lime

When ferrous sulphates is added first (with bicarbonate alkalinity),

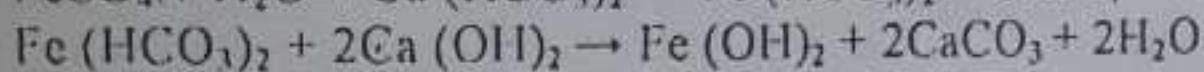

When lime is added first,

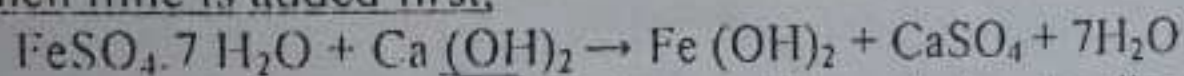

In above equations Fe(OH)₂ is unstable and absorbs dissolved oxygen and forms the stable floc.

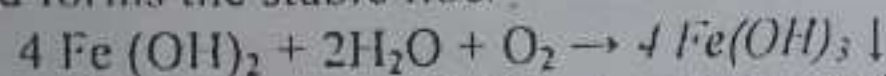

The effective range of pH value for coagulation with ferrous sulphates and lime is 8.5 and above.

(b) *Ferric sulphates [Fe₂(SO₄)₃]:*

It is also used as a coagulant in conjunction with lime and the reaction is, $\text{Fe}_2(\text{SO}_4)_3 + 3\text{Ca}(\text{OH})_2 \rightarrow 2\text{Fe}(\text{OH})_3 \downarrow + 3\text{CaSO}_4$

The effective range of pH for coagulation with ferric sulphates is 4 to 7.

(c) *Ferric chloride [FeCl₃]:*

It is used as a coagulant in conjunction with lime or with out lime.

When used without lime,

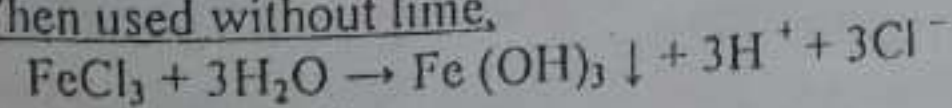

When used with lime,

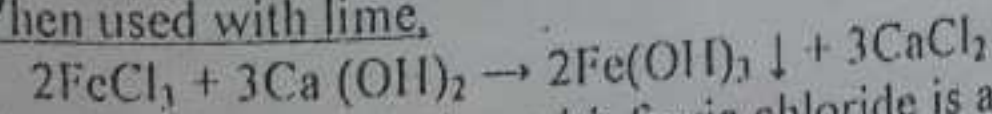

The effective coagulation with ferric chloride is at pH of is 3.5 to 6.5.

Advantages of Iron salts:

1. Produces fast forming, denser, quick settling and less breakable floc than alum at low temperature.
2. Can be used in the wider range of pH and ferric chlorides and/or ferric sulphates may remove manganese at > 9 pH.
3. Ferric chloride is effective in removing H₂S, taste and odour.

Disadvantages of Iron salts:

1. Additional lime increases the treatment cost and iron salts impart more corrosiveness to water than alum.
2. Iron salts are difficult to handle due to corrosiveness and require skilled supervision on application.
3. Promotes the growth of bacteria in distribution system.
4. It is suitable for sewage treatment.

3. Chlorinated copperas [FeCl₃.Fe₂(SO₄)₃]:

The mixture of ferric chloride and ferric sulphate is called chlorinated copperas and prepared by adding 1 part chlorine to 7.8 part ferrous sulphate.

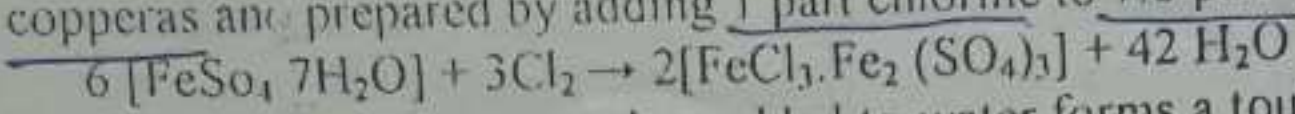

This chlorinated copperas when added to water forms a tough floc which is removed in sedimentation. The effective range of chlorinated copperas is from pH of 6 to 8. It is effective to remove colour but very corrosive and common in sewage treatment.

4. Sodium aluminate [Na₂Al₂O₄]:

It is sometimes used as coagulants. This chemical when dissolved and mixed with water reacts with salts of calcium and magnesium and forms the precipitates of calcium and magnesium aluminate.

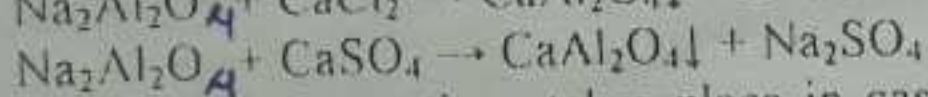
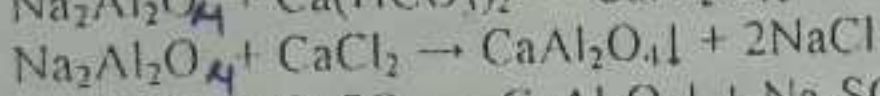
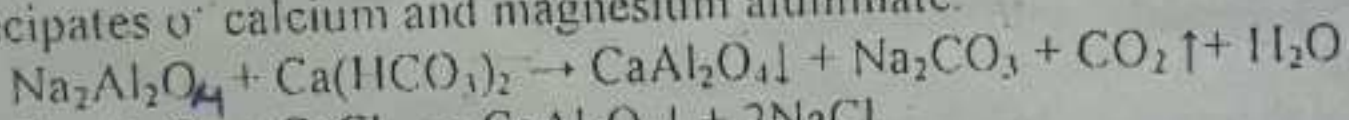

Similar chemical reactions takes place in case of Mg salts. The effective range of pH for coagulation with sodium aluminate is 6 to 8.5. This removes temporary and permanent hardness but very costly and not used in public water supplies and used to treat boiler water.

6.11 PROCESS OF SEDIMENTATION WITH COAGULATION

Following operations are involved in sedimentation with coagulation:

- | | |
|--------------------------|------------------------|
| 1. Feeding the coagulant | 2. Mixing of coagulant |
| 3. Flocculation | 4. Sedimentation |

1. Feeding the coagulant:

The coagulant may feed to raw water either in powder form (called dry feeding) or in solution form (called wet feeding). Coagulants feeding are done with using dry feeding or wet feeding devices. The choice between wet and dry feeding depends on:

- a. Characteristics of coagulant and convenience of its application.
- b. Dosages of coagulants: High dose dry feed and vice versa.
- c. Size of the treatment plant: Large size wet feeder is used and vice versa.

2. Mixing of coagulant:

After the addition of coagulants to raw water it is thoroughly and vigorously mixed so that the coagulants get fully dispersed in the entire mass of water. Various mixing devices are as follows but the first two types are common and are described here.

- a. Mixing basin with baffle walls
- b. Mixing basin with mechanical means
- c. Mixing channels
- d. Hydraulic jump method
- e. Compressed air method
- f. Centrifugal pumping method

(a) Mixing basin with baffle walls:

These are the rectangular basins or tanks which are provided with baffle walls. The disturbance created by the presence of baffle walls in the path of following water cause vigorous agitation of water which results in thorough mixing of water with coagulant. Such basins are of two types:

i) Horizontal or round end type:

The mixture and coagulants after entering the basin through an inlet provided at one end of the basin, flows horizontally for short distance and due to the presence of the baffle walls it takes turn and moves further as shown by the arrows in fig 6.12, and comes out through an outlet provided at the other end of the basin to the flocculator.

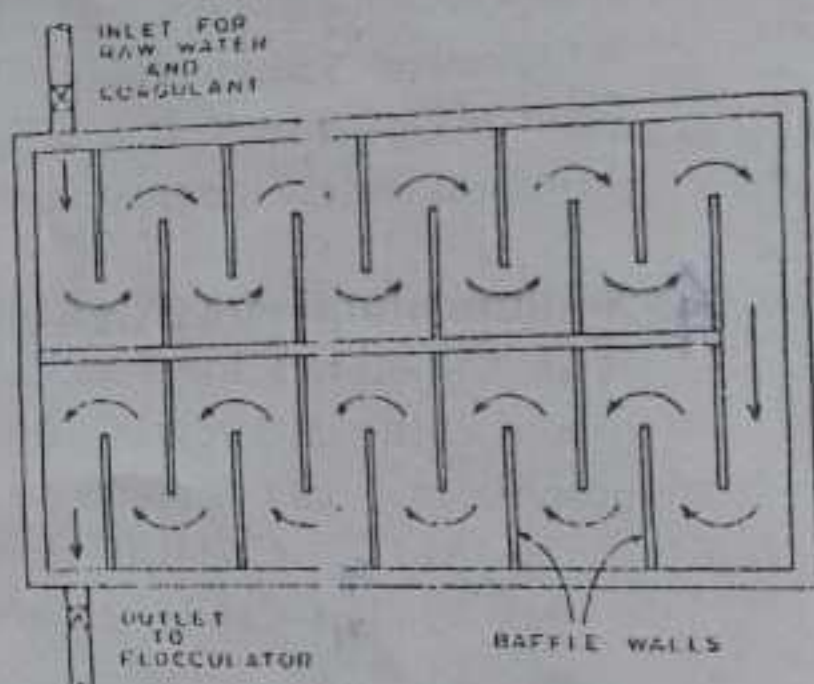

Fig 6.12 Horizontal or round end type mixing basin

ii) Vertical or over and under type:

The mixture of water and coagulant after entering the basin through an inlet provide at one end of the basin, flows up and down as shown by the arrow in fig 6.13 due to the presence of vertical walls projecting alternatively from the roof and the floor of the basin. Ultimately it flows out through outlet at the other end of the basin to the flocculator.

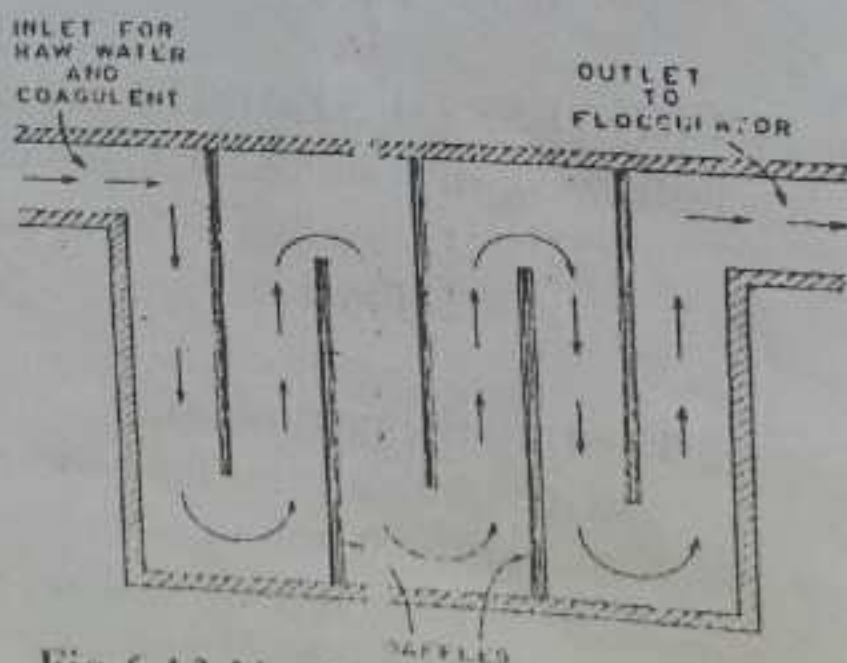

Fig 6.13 Vertical or over and under type mixing basin

Mixing basin should be properly designed to get the desired effect. The various considerations for design are

- a. Velocity of flow in the channel should be between 0.15 m/s to 0.45 m/s (between baffle walls)
- b. Detention period kept is 20 to 50 minutes.
- c. Distance between successive baffle walls should be at least 0.45 m.
- d. End opening between end baffle walls and basin walls should be about 1.5 times the distance between the successive baffle walls subjected to minimum 0.6 m.

(b) **Mixing basin with mechanical means:**
 Mixing basin with baffle walls are used only for small treatment plant but for large plant mixing basins with mechanically driven paddles is used (Fig 6.14). It is also called the flash mixture and consists of a deep circular or square tank which is provided with a propeller type impeller fixed at the lower end of a vertical shaft which is driven by electric motor. Diameter of impeller provided is 0.2 to 0.4 times the tank diameter and impeller rotation speed is of 100 rpm.

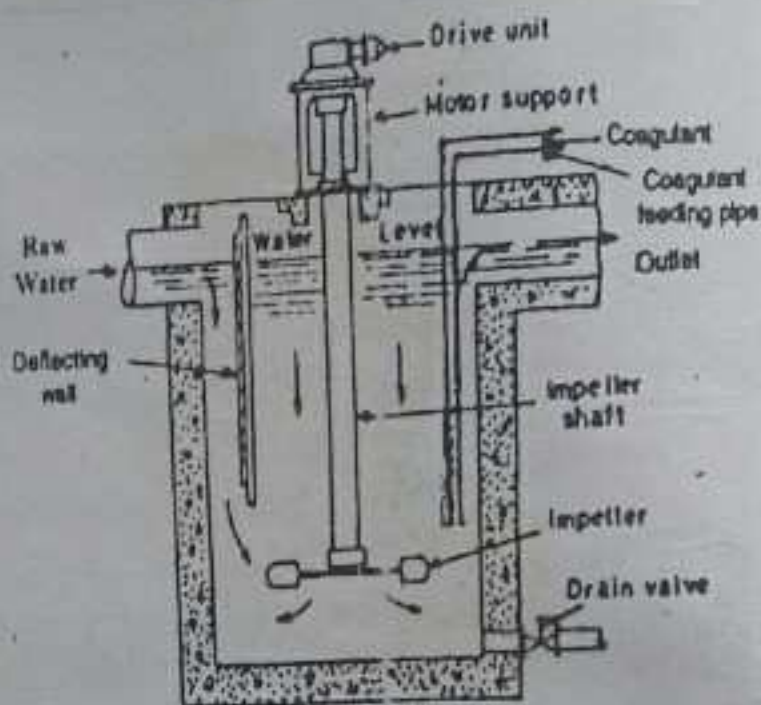

Fig 6.14 Flash Mixture

3. Flocculation:

From the mixing basin, water is taken to the flocculator for flocculation. In a flocculator, slow stirring of water is brought about to permit build up of the floc particles. There are various types of flocculators but the mechanical flocculators are most commonly used.

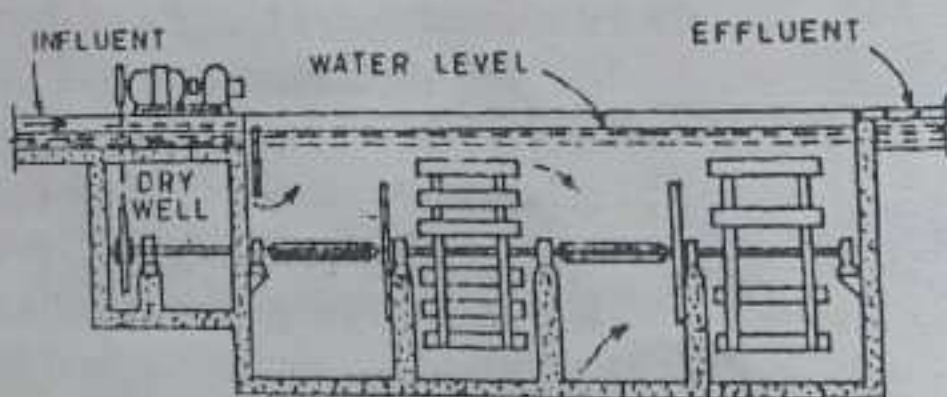

Fig 6.15 Longitudinal flow flocculator

Mechanical flocculator consists of a tank provided with paddles for stirring of water hence it is called paddle flocculator. Depending upon the direction of flow of water in the tank, the mechanical flocculator may be longitudinal flow flocculator or vertical flow flocculator

A longitudinal flow flocculator consists of a rectangular tank provided with paddles revolving on a horizontal shaft as shown in fig 6.15.

A vertical flow flocculator consists of a circular tank provided with paddles revolving on a vertical shaft as shown in fig 6.16. The paddles are moved by electric motor. The water coming from mixing basin enters the flocculator through inlet and leaves through outlet to sedimentation tank. In longitudinal flow flocculator inlet and outlet are provided near the top of tank in opposite end but in vertical type, inlet is provided at the bottom and outlet is provided near the top in opposite end.

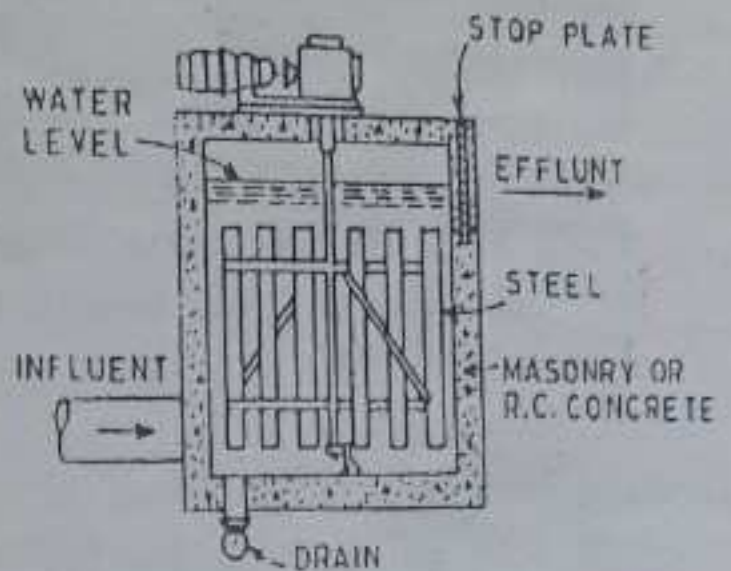

Fig 6.16 Vertical flow flocculator

Design criteria:

- a. Depth of tank = 3 - 4.5 m
- b. Detention period = 10 - 45 min (30 min common)
- c. Velocity of flow = 0.2 - 0.8 m / min (0.4 m/min common)
- d. Total area of paddles = 10-25% (15% common) of X-sectional of area of tank.
- e. Outflow velocity = 0.15 - 0.25 m/s to prevent settling or breaking of floc.

4. Sedimentation:

The water from the flocculator is taken to the sedimentation tank also called coagulation tank or clarifier. It consists of floc chamber and sedimentation tank as shown in fig 6.17. The detention period for floc chamber is about 15 to 40 min. and that for sedimentation tank is about 3 to 4 hrs. The surface overflow rate is from 30 to 40 $m^3/m^2/day$. The depth of floc chamber is usually kept about half of the depth of sedimentation tank. The cleaning of this tank is usually carried out at an interval of 3 to 6 month.

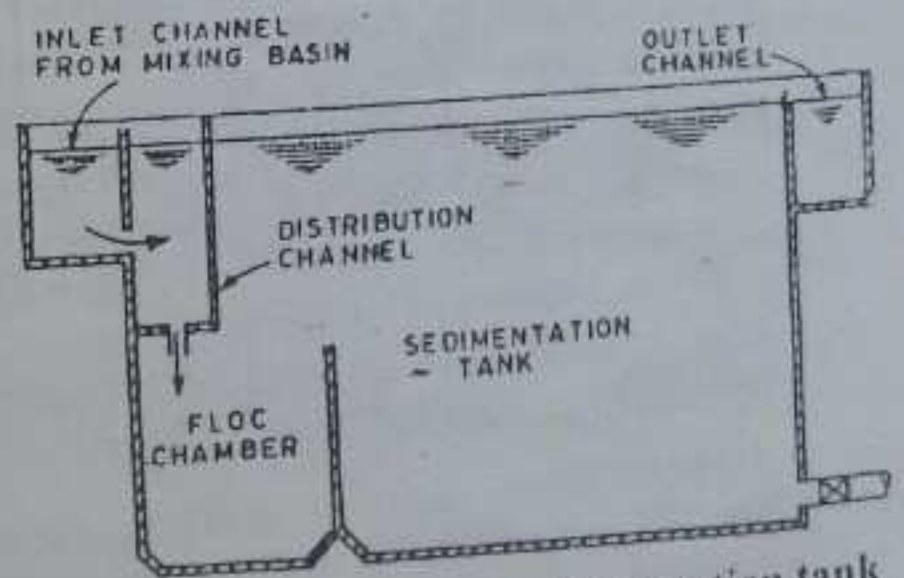

Fig 6.17 Coagulation sedimentation tank

6.12 DORR CLARIFLOCCULATOR

The all four process (coagulant feeding, flash mixing, flocculation and clarification) may be done in a single unit called Dorr clariflocculator (Fig 6.18). The coagulant is fed into raw water through the feeding device and the mixture is thoroughly mixed in the flash mixture then it flows to the

floc particles. The flocculated water is then passed into the clarifier where the floc along with the suspended and colloidal matter present in water settle down and are thus removed. The water from the clarifier then flows to the filter.

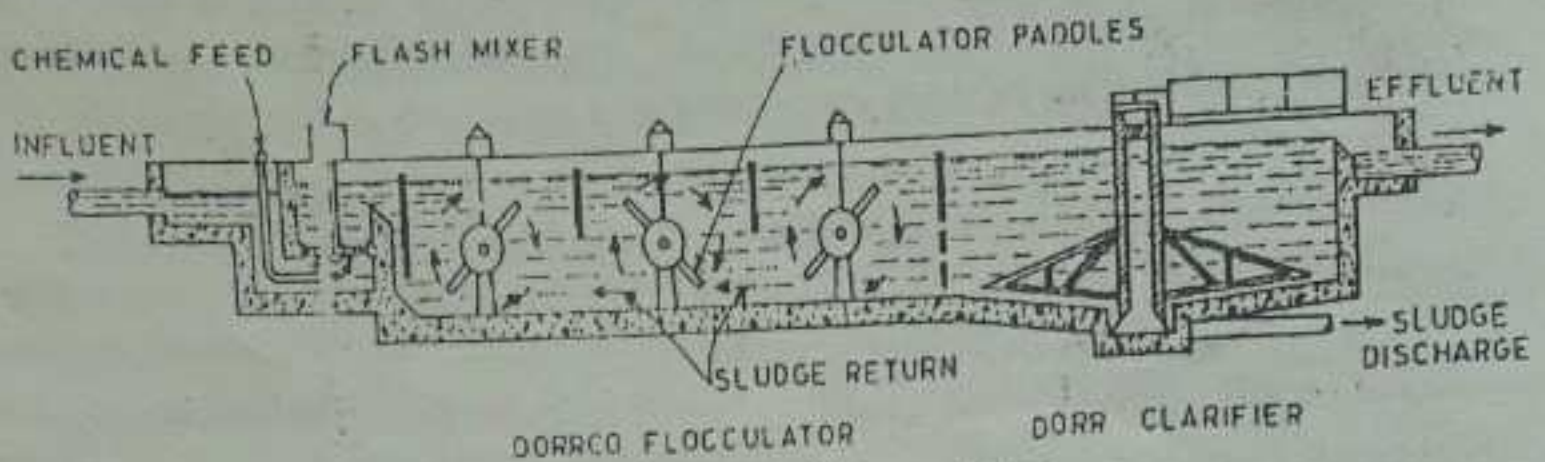

Fig 6.18 Dorr clariflocculator

6.13 FILTRATION

Large amount of suspended and colloidal matters in water is removed by sedimentation with coagulation but it cannot remove very fine floc particles, colour, dissolved minerals, microscopic organisms or bacteria. For removal of such impurities, water is passed through the thick layers of porous media (granular) beds which is called filtration.

In most of the cases the layer of sand supported on a bed of gravel is used as granular or porous media. Anthracite, coal, coconut shells may also be used as the filter media. The main purpose is to remove colour, odour, taste, bacteria and colloidal impurities.

6.14 THEORY OF FILTRATION

When water is allowed to pass through the bed of filter media, the following action takes place

- | | |
|---------------------------|----------------------------------|
| (d) Mechanical straining | (b) Sedimentation and adsorption |
| (c) Biological metabolism | (d) Electrolytic action |

a. Mechanical straining:

Suspended matters larger than the size of interstices (voids between sand grains) cannot pass through them and are trapped or arrested then removed which is called mechanical straining. Due to smaller in size of colloidal matters or bacteria, they may not be strained.

b. Sedimentation and adsorption:

The interstices between the sand grains act as a very smaller sedimentation tanks where the suspended matters settle. Due to physical attraction between the suspended particle and sand grain and presence of gelatinous coating formed due to these matters, other suspended particle, colloidal matters and bacteria adheres there and are removed.

c. Biological metabolism:

Organic matters such as algae, plankton also caught by voids between sand grains and these matters are used by bacteria for survival and convert them into harmless compounds from biological metabolism. These harmless compounds formed are deposited at the surface of sand contains a zoological jelly called 'dirty skin' which further enhances in adsorbing and straining activities. Bacteria not only break organic impurities into harmless compounds but they destroy each other and make a balance life in the filter.

d. Electrolytic action:

As per ionic theory, when two substances of opposite charges come into contact, the charge is neutralized and in doing so, new chemical substances are formed. Sand particles in filter media also have charges of some polarity which attracts the suspended, colloidal and dissolved matters of opposing polarity in neutralizing and changes the chemical characteristics of water.

After a long use charges in the sand grains get exhausted and it becomes necessary to clean filter for regeneration of charges.

6.15 FILTER AND THEIR CLASSIFICATION

A tank or device with filter media used for the filtration is called filter. Based on the filtration rate and driving force to overcome friction by water flowing to filter, filters are classified as follows:

1. Slow sand filter (SSF)
2. Rapid sand filter (RSF)

3. Pressure filter (PF) (also called *pressure filter*)

1. Slow sand filter (SSF):

The earliest type of gravity filters whose rate of filtration is slow ($\leq 1/20^{\text{th}}$ of that than RSF or PF) is called slow sand filter and requires greater quantity of sand and larger surface area. Bed cleaning of SSF is done by surface scraping which involves a lot of labour and cost hence it is suitable if land, labor and sand are readily available at low cost. Pretreatment of water is not needed for < 20 NTU turbidity and can directly fed to filter but if water has high turbidity, plain sedimentation or sometimes (but rarely) sedimentation with coagulation is done before feeding into SSF. Fig 6.19 shows the section of SSF, which consists of following

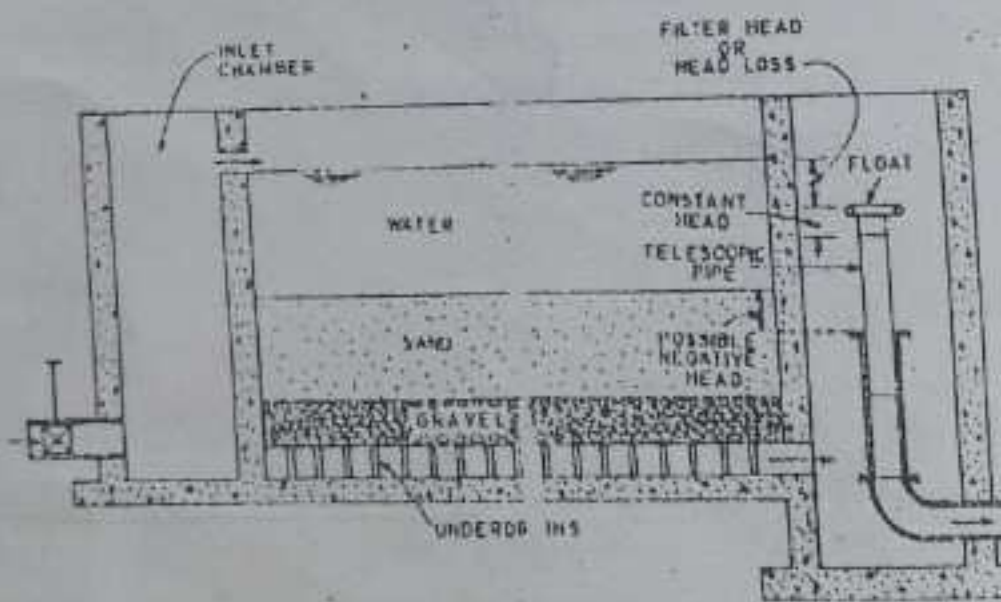

Fig 6.19 Section of slow sand filter

a. *Enclosure tank:*

It is open and water tight rectangular tank made of masonry or concrete. The depth is 2.5 - 3.5 m, surface area is 10 - 2000 m² or more (depends upon filtration rate), filtration rate is 100 - 200 lph/m². The floor is provided at cross slope of 1 in 100 - 1 in 200 towards central drain

b. *Filter media:*

It consists of 90 - 110 cm thick sand layer with effective size (D_{10}) of sand 0.25 - 0.35 mm (0.3 mm is common) and coefficient of uniformity (C_u) of 3 - 5. Finer the sand better will be the removal of turbidity and bacterial removal efficiency but lowers the filtration rate. The sand should not contain >2% of Ca and Mg.

c. *Base material:*

The sand layer is supported on base material of 30 to 75 cm thick gravel bed. The gravel beds are provided four layers of each about 15 cm thicknesses with size 3 - 6 mm, 6 - 20 mm, 20 - 40 mm and 40 - 65 mm from the top. Mid layers between top layer and bottom layer is called intermediate layers.

d. *Under drainage system:*

Fig 6.20 shows the under drainage system which supports filter media and the base material then collects water to deliver it in clear water reservoir. It consists of central main drain and lateral drains 2 - 3 m apart and starts from 50 - 80 cm distance of walls of tank. Lateral drain consists of earthenware or perforated pipes laid with open joint or patented drain in slope

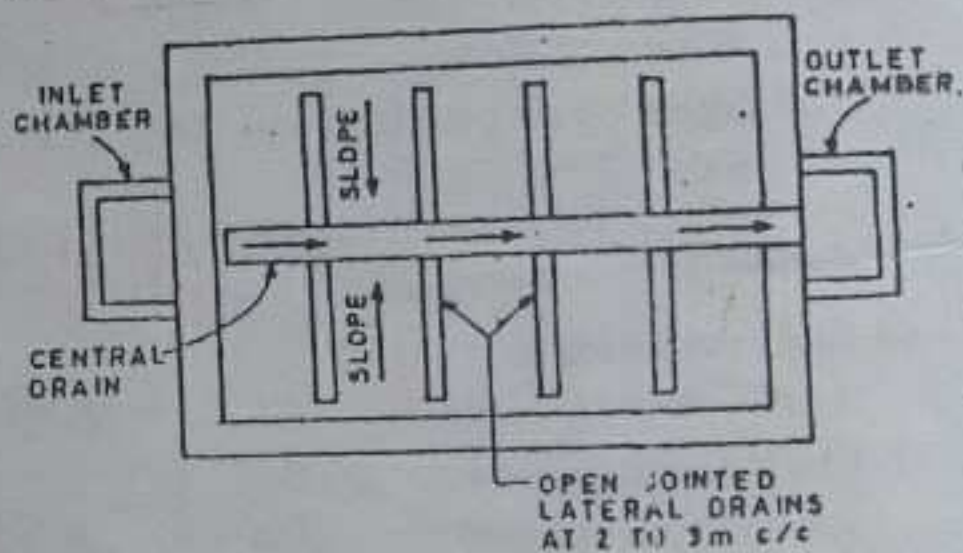

Fig 6.20 Under drainage system of SSF

e. *Appurtenances:*

For efficient working, vertical air pipes, depth controlling devices, head loss measuring device, rate maintaining devices etc are installed

Working & cleaning of SSF:

Water from sedimentation tank enters the filter through inlet then passes through filter media and the purified water is collected by under drains and comes out from outlet to clear water reservoir. The water depth is generally kept equals to the thickness of the sand layer only. During operation, when the depth of water on sand bed reaches the maximum value, it requires cleaning. The top layer of sand is scraped and washed manually or with washers outside the filter. The washed sand is stored for

Methods of disinfection:

- (a) Chlorination
- (b) Boiling
- (c) Excessive lime treatment
- (d) Iodine treatment
- (e) Bromine treatment
- (f) Ozone treatment
- (g) Potassium permanganate treatment
- (h) Silver treatment
- (i) Ultra-violet ray treatment

Among above, chlorination is most effective and commonly adopted and we are concerned with Chlorination in this course.

6.17 CHLORINATION

When chlorine and its compound are used in proper quantity as disinfectant in water is called chlorination.

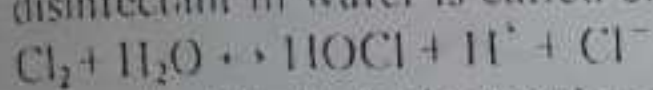

It is called Hydrolysis reaction occurs at 49 - 212°C

The HOCl further dissociates (ionizes) as follows

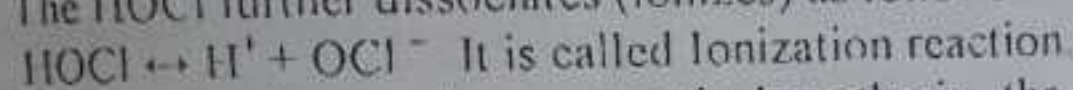

According to the enzymatic hypothesis, the hypochlorous acid (HOCl) and hypochlorite ions (OCl^-) penetrate cell walls and reacts with the enzyme system in the cell of micro-organism which result the death of the micro-organism. For disinfection, the undissociated HOCl is about 80 - 100 times more destructive than OCl^- ion.

The chlorine available in the form of HOCl, OCl^- and Cl_2 is defined as the free available chlorine. If $\text{pH} < 5$, chlorine exists in molecular form; if pH is 5 to 10, HOCl and OCl^- is formed. Generally HOCl is formed in pH of 5 to 7. Chlorine water is unstable and rapid decomposes on exposure to sunlight.

6.18 FORMS OF APPLICATION OF CHLORINE

- (a) Bleaching powder
- (b) Chloramines
- (c) Chlorine gas or liquid chlorine
- (d) Chlorine dioxide

a. Bleaching powder:

Bleaching powder or calcium hypochlorite $\text{Ca}(\text{OCl}_2)$ is a chlorinated lime and when mixed with water it dissociates and reacts with H^+ ions in water.

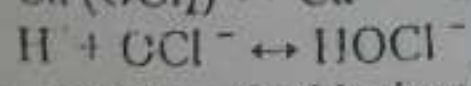
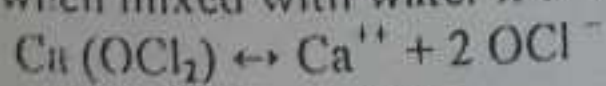

This process of chlorination is called hypochloration. Bleaching powder contains 30 - 35% of available chlorine and it is unstable and goes on losing when exposed to atmosphere. So it requires careful storing. The dose of bleaching powder is 0.5 to 2.5 kg/million liters of water for normal water. It is not adopted for large public water supply but can be used in small colonies and swimming pools.

b. Chloramines

Chloramines are compound formed by reaction between ammonia and chlorine. Ammonia which is quickly soluble in water is added just before chlorine (1 part ammonia + 4.5 part Cl)

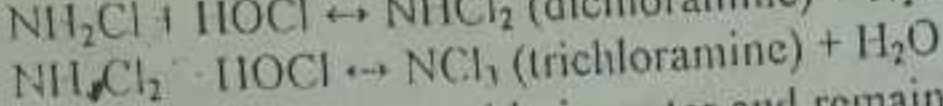
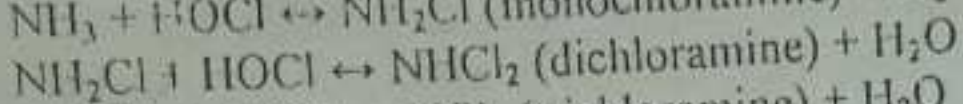
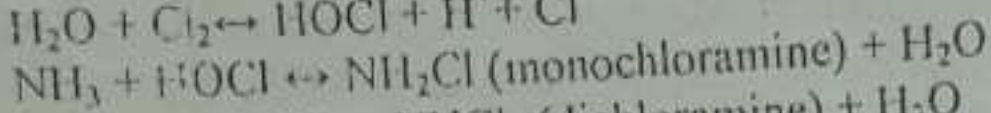
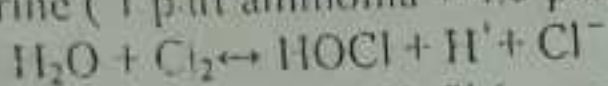

The compounds are quite stable in water and remains in water as residual for a sufficient time so are more effective than chlorine alone. The reaction is slow hence water treated can only be supplied to consumer after 20 minutes to 1 hours of application. It does not cause bad taste and odour when left at residual but as they are weaker disinfectant than free chlorine disinfectant.

c. Chlorine gas or liquid chlorine or free chlorine:

Chlorine gas is fed directly to the point of application to the water supply in a pressure of 7 kg/cm² or first dissolved in small flow of water than free chlorine disinfectant. Application of gas chlorine is less expensive but less satisfactory because of poor diffusion of chlorine and at lower temperature crystalline hydrates of Cl are formed and possibility of choking of pipe. Undissolved Cl may corrode pipes and valves. Hence it is not generally used. If used, chlorine gas or liquid chlorine is dissolved in small quantity of water in normal.

d. Chlorine-dioxide:

In this method chlorine dioxide gas is produced by passing chlorine gas through sodium chloride solution. The Cl is unstable and reacts as follows:

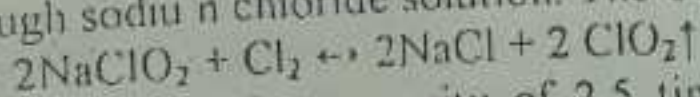

ClO₂ has oxidizing capacity of 2.5 times than that of chlorine and most effective for removal of taste and odour.

6.19 CHLORINE DEMAND AND DOSE

Chlorine demand:

Some free chlorine is consumed in oxidation of organic and inorganic matters present in water to form combined available chlorine which have weak disinfection capacity. The amount of free chlorine consumed in such oxidation is called chlorine demand of water. Hence,

Chlorine demand = Total amount of chlorine added - Amount of residual chlorine required after a specified contact period

Reaction for combined available chlorine:

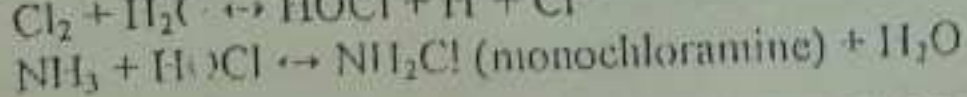
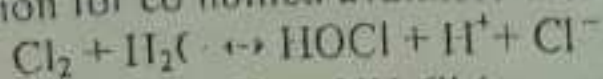

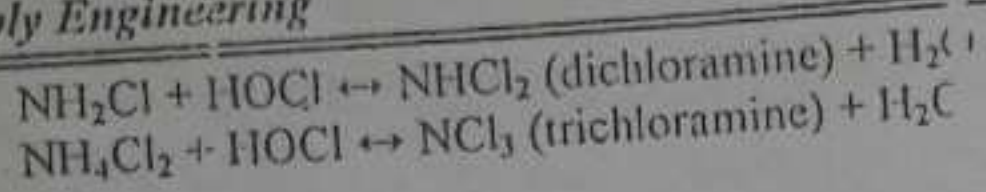

Chlorine dose:

The quantity of chlorine required to be added to water to leave 0.2 mg/l or ppm of freely available residual chlorine after 10 minutes of contact period is called optimum dose of chlorine. This is generally of about 1 ppm. In lab various doses of chlorine are added to equal volume of water and tested after 10 minute of contact period. The dose which leaves 0.2 ppm of free residual chlorine is taken as the optimum dose of chlorine.

6.20 FORMS OF CHLORINATION

Depending upon the stage of treatment at which chlorine is applied to water and also upon the expected results of application of chlorine; chlorination may be of the following forms:

1. Plain chlorination or simple chlorination:

Application of chlorine to plain or raw water is called plain chlorination. Dose of plain chlorination is 0.5 to 1 ppm.

2. Pre-chlorination:

Application of chlorine to water before the treatment is called pre-chlorination. Specially, we use before filtration. Dose adjusted for residual chlorine of 0.1 to 0.5 ppm.

Advantages of pre-chlorination are as follows:

- a. Reduces the quantity of coagulants required.
- b. Reduces the bacterial load in the filters.
- c. It helps in maintaining and running filters longer.
- d. It controls the algae and planktons in the filter.
- e. It eliminates taste and odour.

3. Post chlorination:

Application of chlorine after the treatment is called post chlorination. It is applied after the filtration and before entering into the distribution pipe. Doses adjusted so that it leaves residual chlorine of 0.1 to 0.2 ppm.

4. Double or multiple chlorination:

When raw water contains large number of bacteria, chlorine is applied at two or more points in purification process, it is called double or multiple-chlorination. It consists of pre-chlorination just before raw water enters the sedimentation tank and post chlorination at water leaves the filter and before entering the distribution system.

5. Break point chlorination or free residual chlorination:
When chlorine is added to water, the following two actions take place:
- Kills the bacteria present in water thus disinfection is accomplished
 - Oxidizes the organic matter present in water (chlorine demand is satisfied)

If water has no chlorine demand, any chlorine added to such water will appear as residual chlorine and hence relation between applied and residual chlorine will be as indicated by line A having slope of 45 degrees as shown in fig 6.24. However water generally has chlorine demand, so the relation between applied and residual chlorine will be as indicated by curve B.

The shape of the curve B results from the fact that when chlorine is first applied, it kills bacteria and it reacts with compounds (such as ammonia, proteins, amino acids and phenols that may be present in water) to form chloramines and chloroderivatives which constitutes the combine available chlorine. The combine available chlorine is also recorded as the residual chlorine along with the freely available chlorine.

Therefore with the increase in applied chlorine, the residual chlorine also increases and the curve B goes on rising till point C is reached where the amount of residual chlorine is recorded as maximum. At this stage, with further increase in applied chlorine, there is sudden decrease in residual chlorine due to the fact that the increase concentration of the applied chlorine breaks down chloramines by changing them to nitrogen compounds which reduces the residual chlorine and also a lot of chlorine is applied for oxidation of organic matters present in water. This stage is accomplished by bad smell. During this stage, the relationship between applied and residual chlorine is represented by curve CD. At point D the bad smell and taste suddenly disappears and oxidation of organic matter is also complete. At point D the residual chlorine has its minimum value which indicates the true residual free chlorine.

The break point in the chlorination of water may be defined as the point on the applied residual chlorine curve at which all or nearly all the residual chlorine is the free chlorine. In other words, the application of chlorine to the water with chlorine dose equal to or slightly higher than that at which break point occurs is known as break point chlorination.

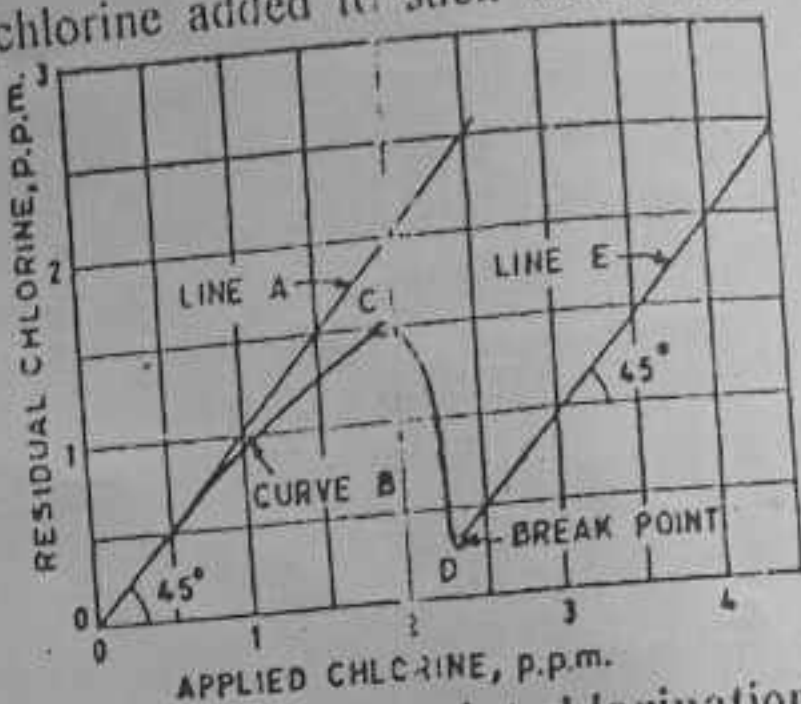

Fig 6.24 Break point chlorination

Break point chlorination has the following effects:

- a. It removes taste, odour and manganese.
- b. It has adequate bacterial effect.
- c. It has the desired residual chlorine. *→ it will leave a desired residual chlorine*
- d. it completes the oxidation of ammonia and other compounds.
- e. *it will remove manganese.*

6. Super chlorination:

Application of chlorine beyond the break point chlorination is called super-chlorination. Generally 2 to 3 ppm beyond the break point is applied for super-chlorination. Super-chlorination is done during epidemics in a certain locality due to water borne diseases.

7. De-chlorination

The process of removing excessive chlorine from water before distribution to the consumers to avoid chlorine taste is known as de-chlorination. It is done either by aeration or ^{adding chemicals such as} sodium thiosulphate, sodium metabisulphate, sodium sulphite, sodium bisulphate, ammonia and sulphur dioxide.

6.21 FACTORS AFFECTING BACTERIAL EFFICIENCY OF CHLORINE

The killing efficiency of bacteria due to chlorination is called bacterial efficiency of chlorine which depends upon the following factors:

1. Turbidity: If turbidity is present in water bacterial efficiency is decreased hence for effective chlorination water should be turbidity free.
2. Presence of metallic compound: More chlorine is utilized to oxidize metallic ions therefore bacterial efficiency is decreased.
3. Ammonia compound: Efficiency is decreased due to formation of combined available chlorine but it lasts for longer time.
4. pH value of water: If pH is high in water, efficiency is low because HOCl is formed at pH of 5 to 7.
5. Temperature: If temperature decreased, amount of free available chlorine is decreased so the efficiency of chlorine is decreased.
6. Time of contact: For effective chlorination time of contact should be at least 20-30 minutes.
7. Type, condition and concentration of micro-organism: For bacteria efficiency is high but for viruses, more concentration is required and efficiency is low. Efficiency becomes low if the favorable condition for bacteria is available and concentration of bacteria is high.

6.22 WATER SOFTENING

There are two types of hardness (temporary and permanent) which was described in chapter 4 of this course. Water softening is the process of removing hardness of water. The main purpose of water softening is to remove hardness in the water.

A. Removal of temporary hardness:

Mainly it is due to presence of carbonate and bicarbonate of Mg and Ca. It is removed by: (a) Boiling (b) Adding lime

(a) Boiling:

It is costlier and not used in public water supply.

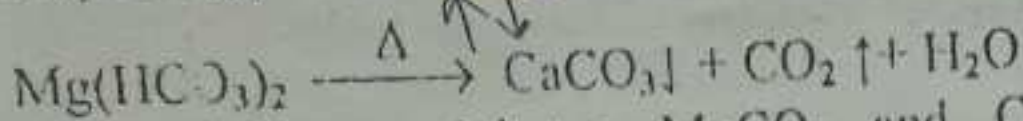
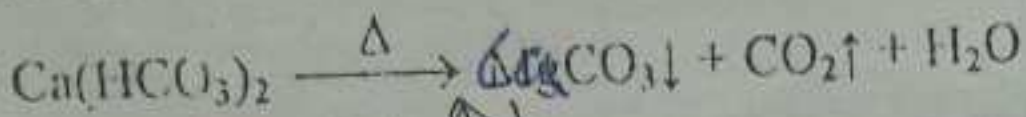

The insoluble precipitates MgCO_3 and CaCO_3 are removed by sedimentation.

(b) Adding lime:

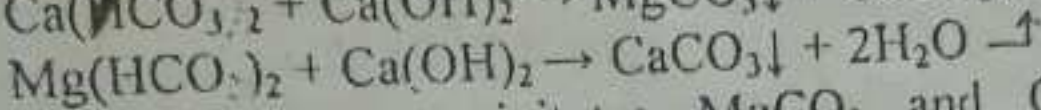
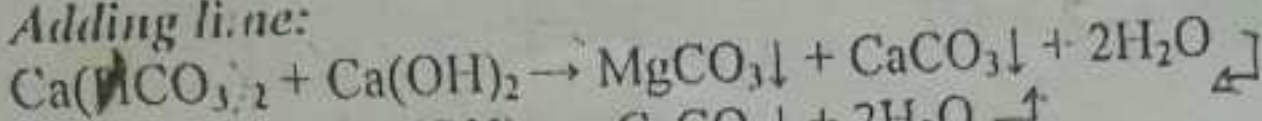

The insoluble precipitates MgCO_3 and CaCO_3 are removed by sedimentation.

B. Removal of permanent hardness:

Mainly it is due to sulphate, chloride and nitrates of Mg and Ca. It is removed by: (a) Lime soda process (b) Zeolite or base exchange process; (c) Demineralization or deionization process

a. Lime soda process:

In this process lime $\text{Ca}(\text{OH})_2$ and sodium carbonate Na_2CO_3 is added to water either separately or together and allow them for 30 – 60 minutes for reaction. It removes permanent as well as temporary hardness.

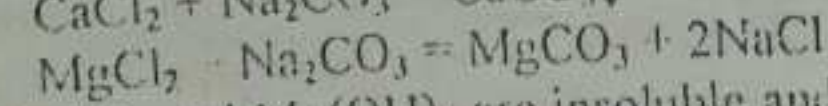
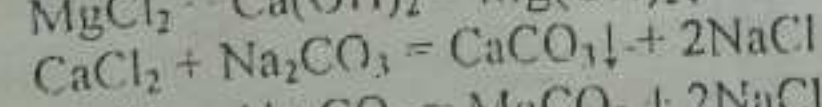
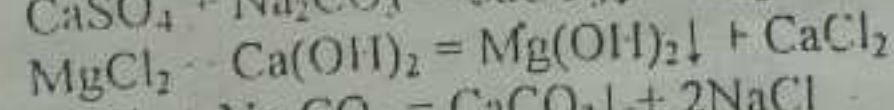
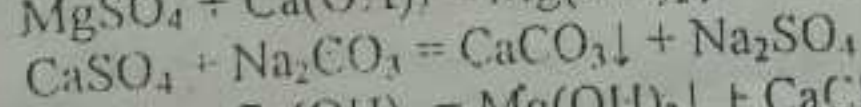
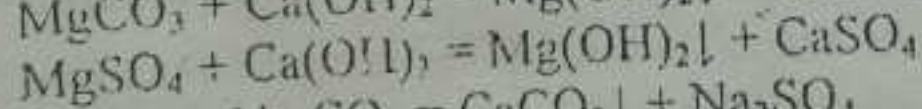
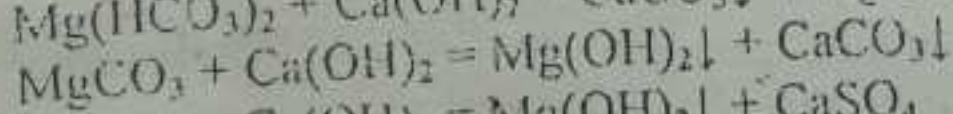
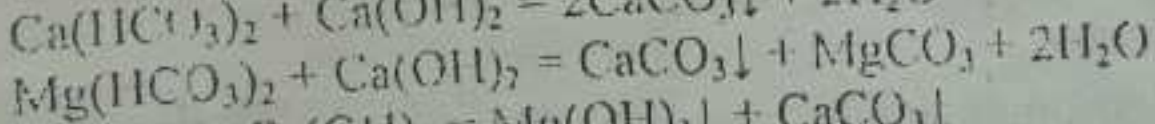
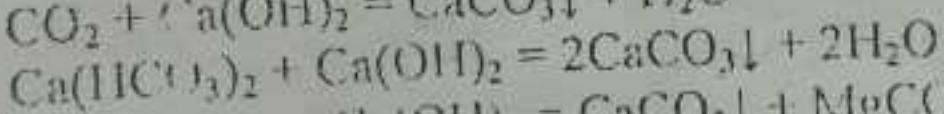
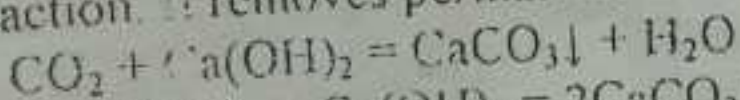

CaCO_3 and $\text{Mg}(\text{OH})_2$ are insoluble and removed by sedimentation. Other products are soluble and do not impart in hardness. This process is economical but a large quantity of sludge is formed and requires skilled supervision.

b. Zeolite or base exchange or ion exchange process:

It is also called Base Exchange or ion exchange process. It also removes temporary hardness and commonly used process. Zeolite is a natural or artificial granular substance. Natural zeolite is green in colour and

artificial is white and commonly used also called permutit. The commonly used permutit is sodium aluminum silicate ($\text{SiO}_2 \cdot \text{Al}_2\text{O}_3 \cdot \text{Na}_2\text{O}$) and permutit is manufactured from feldspar kaolin and soda.

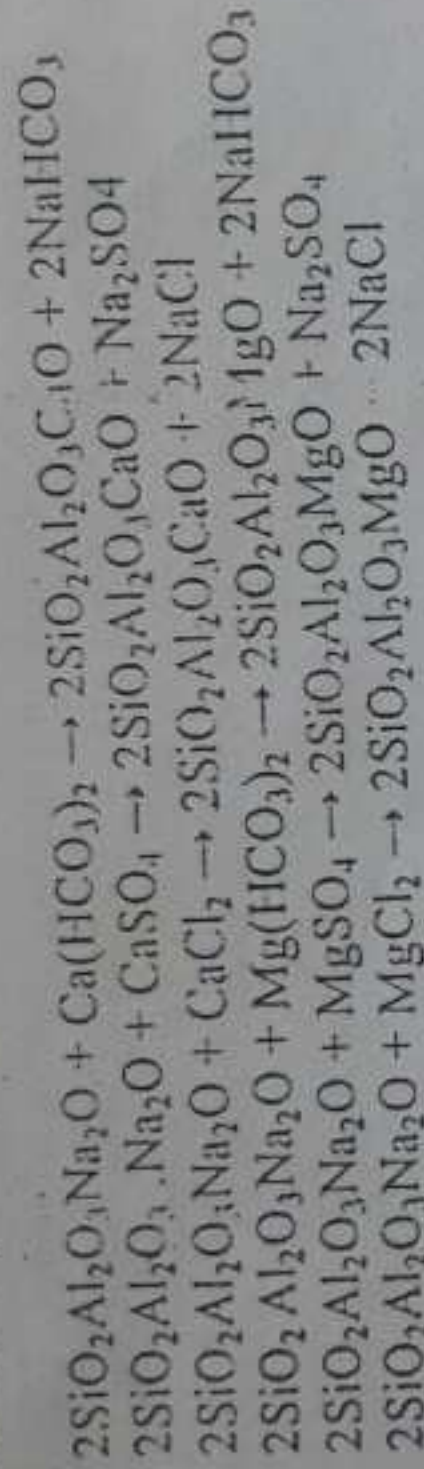

If we denote permutit as Na_2Z (Z is anionic component of the exchanger),

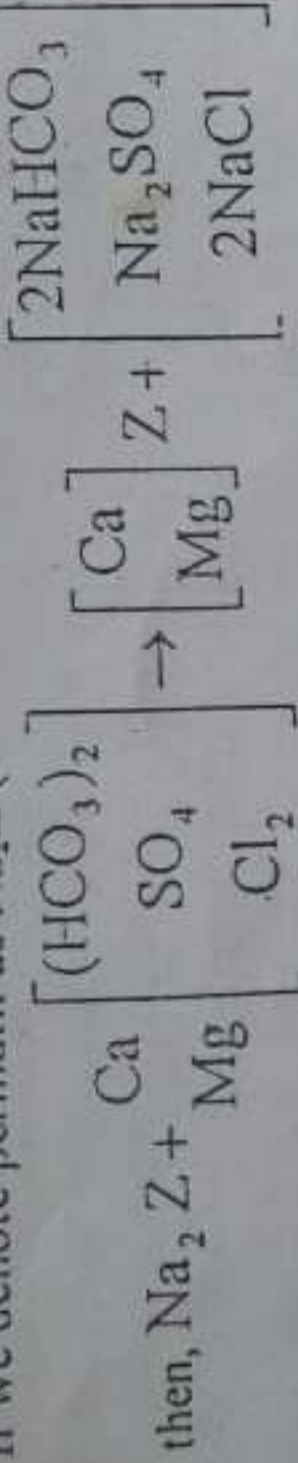

Here, the calcium and magnesium is replaced by sodium and water and the sodium salts formed are soluble in water but do not impart hardness and water is softened. The product $2\text{SiO}_2 \cdot \text{Al}_2\text{O}_3 \cdot \text{CaO}$ remains in zeolite.

A typical zeolite water softener is shown in fig 6.25.

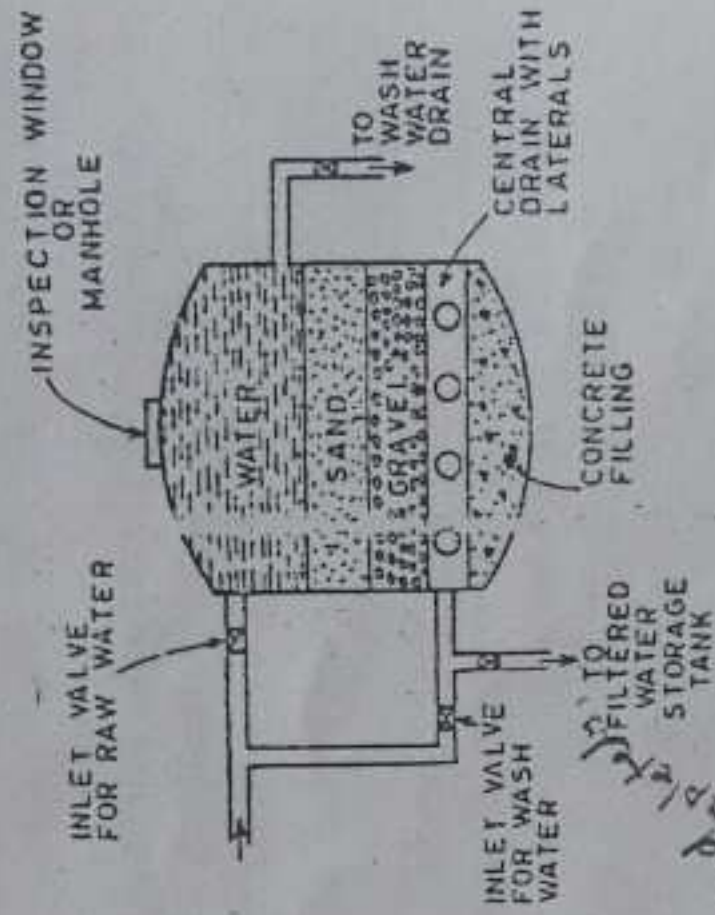

Regeneration of zeolite:

Due to continuous use of zeolite, it exhausts and zeolite doesn't work. It can be checked by soap solution test. If it get exhausted, it needs regeneration by passing NaCl in it.

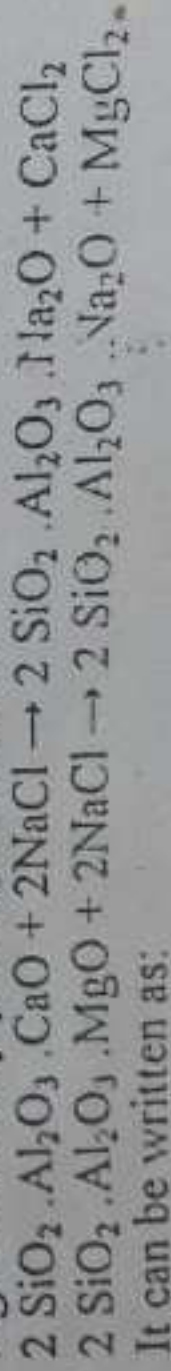

It can be written as:

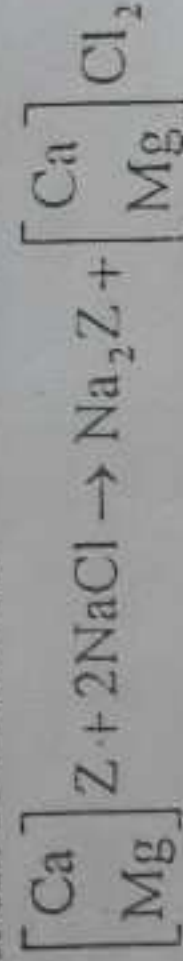

Fig 6.25 Zeolite water softener

Advantages:

1. No sludge is formed.
2. Compact and small space is required.
3. Because of simplicity in operation, no skilled persons are required.
4. Hardness may reduce to zero.
5. No other chemicals are required.

Disadvantage:

1. Not suitable for turbid water and water containing Fe and Mn.
2. Growth of bacteria occurs in zeolite if water contains organic matters.

c. Demineralization or deionization process:

It is the costlier process but used in industries. It is very similar to zeolite process but metallic ions are exchanged for hydrogen ions and substances like zeolite is used. The substances may be:

1. Acidic Resin (removes alkali substances) eg: zero carb, organolite, catex etc.
2. Base Resin (removes acidic substances)

If we denote these resins as H_2R (H means hydrogen and R means organic part of the substance), then,

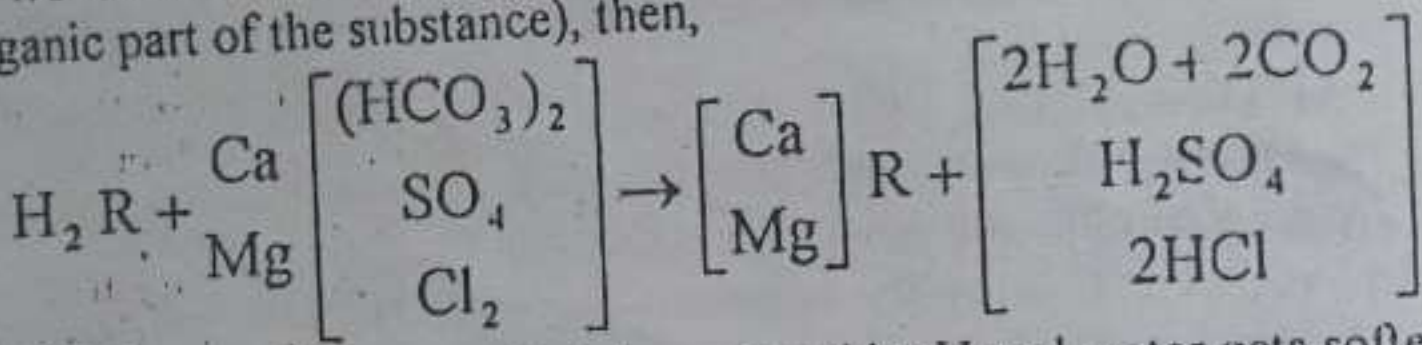

In above process Ca and Mg is replaced by H and water gets softened.

Disadvantage:

The disadvantage of this process is that acids are formed. If the quantity of acid is high it is removed by:

- i. Diluting treated water with raw water
- ii. Neutralizing treated water with alkaline substance and
- iii. Absorbing excessive acids by de-acidic substance 'D' regenerated with sodium or caustic soda.

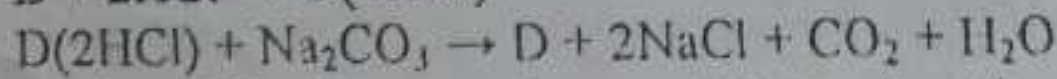
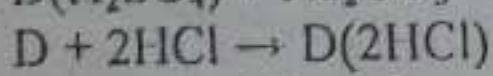
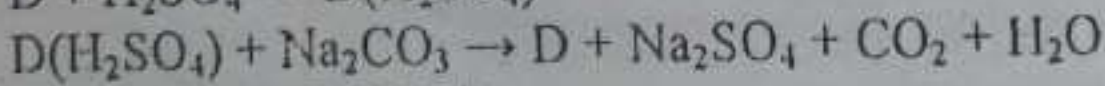
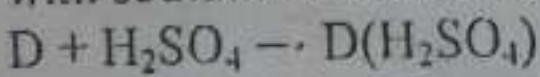

Regeneration of Hydrogen exchanger 'R' at exhaustion after long use:

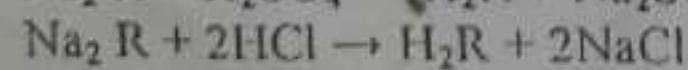
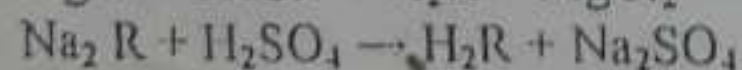
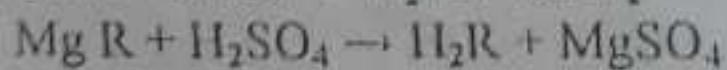
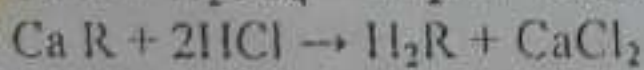
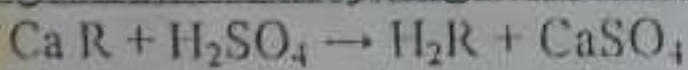

The reaction can be represented as:

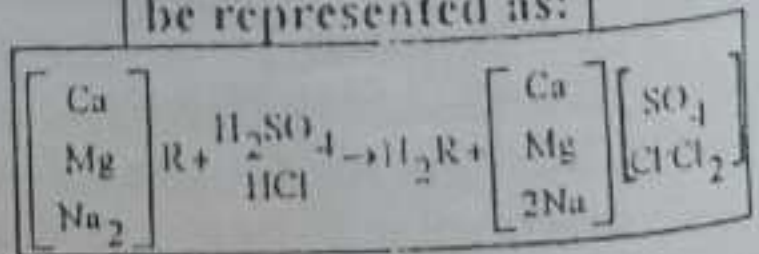

MISCELLANEOUS TREATMENT

6.23 Besides the various methods of treatment described earlier, certain other methods of water treatment are required for specific purpose. The following miscellaneous treatment methods are described here.

- A. Aeration
- B. Removal of iron and manganese
- C. Removal of colour odour and taste

Aeration:

Aeration is a method used to bring the water into contact with the atmospheric air so that oxygen is observed from air and objectionable gases, odour, taste etc are released in atmosphere. Also iron, manganese and other certain organic impurities are also removed by aeration. Excessive aeration causes excessive oxygen absorption which further increases corrosiveness of pipes.

Purpose of aeration:

1. To make water fresh by absorbing oxygen from air.
2. To release dissolved gases (CO_2 , H_2S etc) to atmosphere.
3. To remove bad taste and odour.
4. To reduce corrosiveness of water.
5. To precipitate Fe and Mn to some extent by oxidizing.
6. To kill harmful bacteria to some extent.
7. To mix mixing chemicals to water.

Methods of aeration:

Different aerators are used for different methods of aeration.

- (a) Free fall or gravity aerators:
 - (i) Cascade (ii) Inclined (iii) Salt tray (iv) Gravel packed bed aerator
 - (b) Spray aerators (c) Diffuse aerators (d) Mechanical aerators

i. Free fall or gravity aerators:

i. Cascade aerator:

In this aerator, water is allowed to fall from 1 to 3 m height over a series of 4 to 6 concrete steps in thin film. During falling, water is mixed with air and gets aerated. (See fig 6.26). It removes 20 - 45% CO_2 and 35% of H_2S .



Fig 6.26 Cascade aerator

ii. Inclined apron with riffle plate aerator:

In this aerator, water is allowed to fall in inclined plain with riffle plates. (See fig 6.27)



Fig 6.27 Inclined aerator

iii. Salt tray aerator:

It is the commonly used aerator and consists of round or square structure containing closely stacked wood-salt (thin narrow pieces) trays. Water is allowed to pass through trays from top and air from bottom is blown for aeration and aerated water is collected from outlet at the bottom. (See fig 6.28). Ventilator allows air and gases escape to the atmosphere.

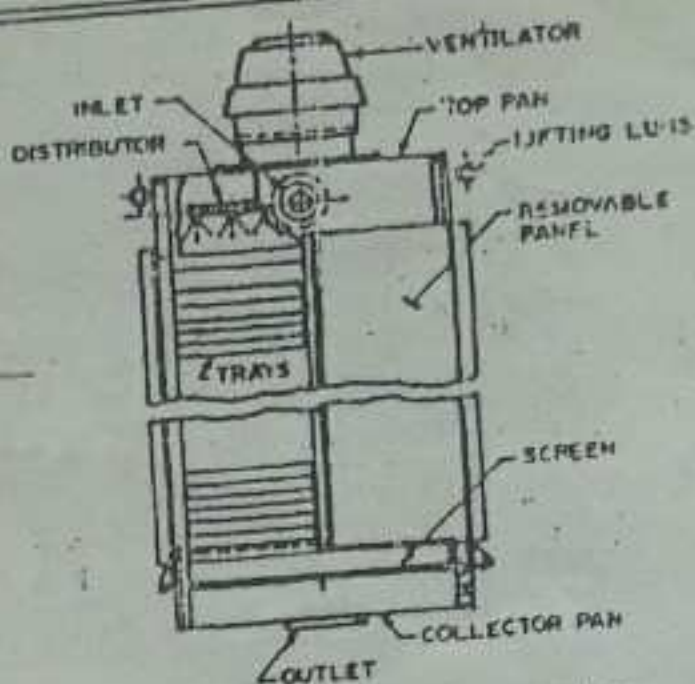

Fig 6.28 Salt tray aerator

iv. Gravel packed bed or trickling bed aerator:

CO_2 removal is high if water is cascaded through beds of coke, limestone or gravel. In gravel bed aerator, water is passed from top and air is blown from bottom and aerated water is collected from bottom. (See fig 6.29).

In trickling beds of coke which are supported on the perforated bottom of trays, water is allowed from top and at downward movement water gets air and aeration takes place. (See fig 6.30). It is efficient for CO_2

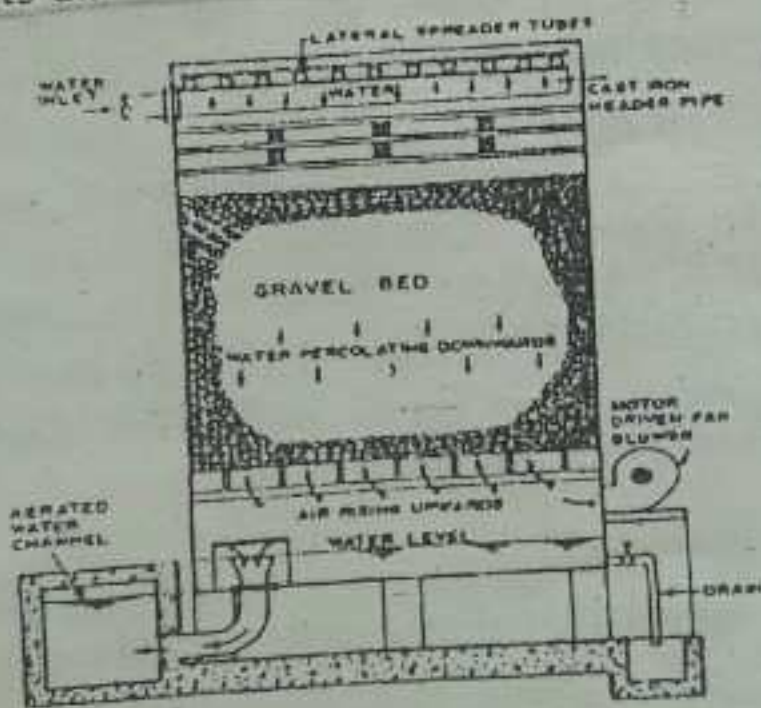

Fig 6.29 Gravel packed bed aerator

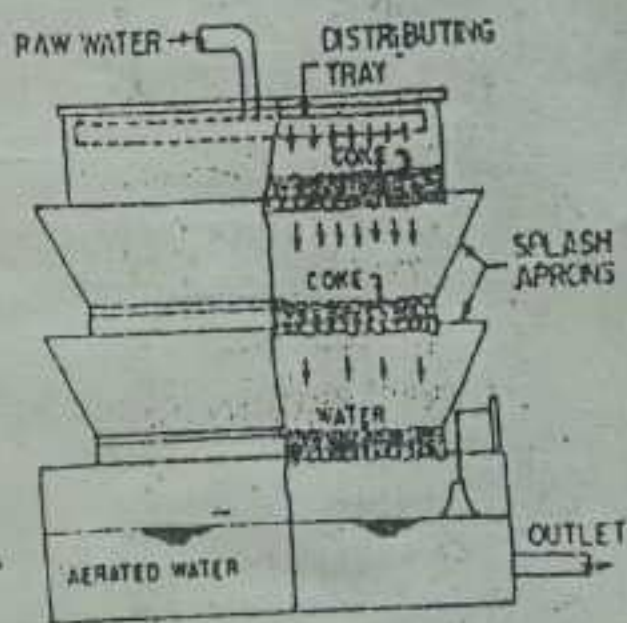

Fig 6.30 Trickling bed aerator

b. Spray aerators:

In this aerator water flow is divided into fine streams and small droplets which come into contact with air and aeration takes place. In

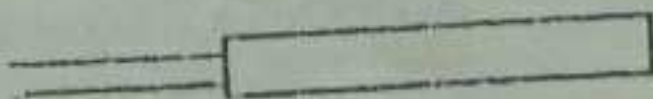

Fig 6.31 Spray aerator

Water Supply Engineering

this method, the water is sprayed to atmosphere through nozzle at a pressure of $0.70 - 1.5 \text{ kg/cm}^2$ for aeration. (See fig 6.31). It can remove 70 - 90% of CO_2 .

c. Diffuse aerators:

In this aerator, perforated pipe network is installed at the bottom of aeration tank and compressed air is blown through these pipe networks. (See fig 6.32). The air bubble travels upward through water causes aeration. Air diffuser basins have a retention period of about 15 minutes and a depth of 3 - 5m.

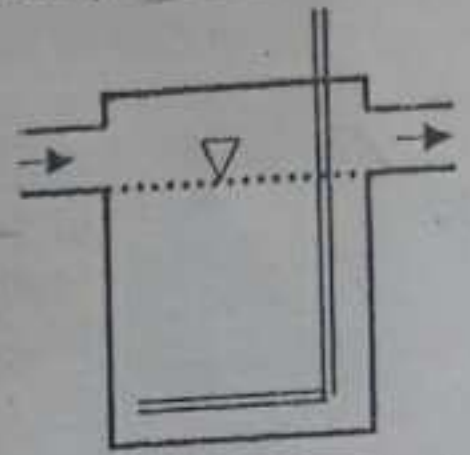

Fig 6.32 Diffused air aerator

d. Mechanical aerators:

In this method, aeration is done in a tank with mechanical rotating device which mixes air in water. (See fig 6.33)

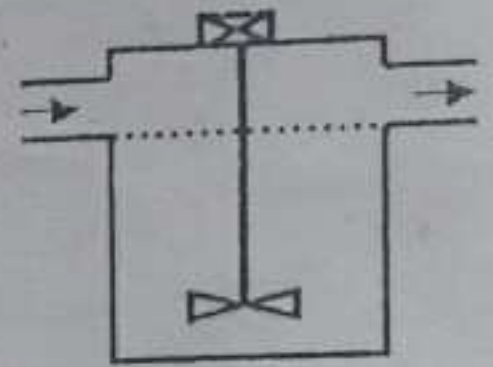

Fig 6.33 Mechanical aerator

B. Removal of iron and manganese:

Iron and manganese mix into water through soils either in suspension, hydrated oxides, soluble or insoluble form. $[\text{Fe}(\text{OH})_3]$ is insoluble and $[\text{Fe}(\text{HCO}_3)_2]$ is soluble in water. When iron and manganese $> 0.3 \text{ ppm}$, they become objectionable. Insoluble $\text{Fe}(\text{OH})_3$ is removed in sedimentation.

Effects:

- Produce taste, odour and brown red colour.
- Stains on clothes, corrosion and clogging of pipes by accumulation of precipitates.
- Causes difficult in various industrial process.

Purpose:

The main purpose is to remove iron and manganese to reduce their effects.

Methods:

- (a) By aeration: In this case aeration is done before sedimentation.

Fe:



$\text{Fe}(\text{HCO}_3)_2$:

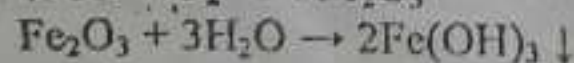
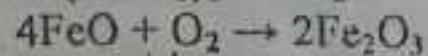

Mn:

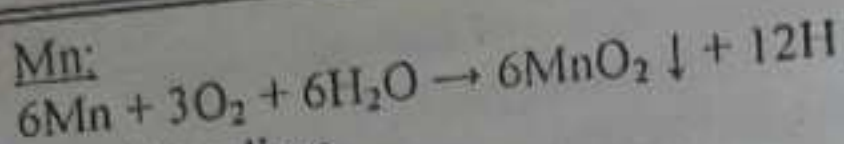

(b) By adding lime

(c) Passing over manganese zeolite

C. Removal of colour odour and taste:

Colour, odour and taste is due to organic and vegetable matters, industrial waste, domestic sewage, dissolved gases and minerals and microorganisms etc.

Purpose:

The main purpose is to remove colour, odour and taste.

Methods:

The colour, odour and taste is removed to some extent in sedimentation with coagulation followed by filtration, pre chlorination etc. For effective removal of these following methods are used:

(a) Aeration:

(b) Activated carbon treatment:

It is the commonly used process for removal of colour, odour and taste. Activated carbon is manufactured by heating saw dust, paper mill waste etc. at 500°C in a closed vessel in controlled condition of burning at 800°C . It is readily available in market in powder or granular form. The powder is mixed with water before filtration and granular is used as filter materials. It absorbs organic matters and removes colour, odour and taste.

(c) Using copper sulphate (CuSO_4):

It is available in powder or crystal form and easily soluble in water. It is applied in the distribution system or reservoirs to 0.3 – 0.65 ppm. Its application is common in swimming pools.



CHAPTER 7. RESERVOIRS AND DISTRIBUTION SYSTEM

7.1 RESERVOIRS

- To store water, a device or tank is used which is called reservoir.
- The storage may be Public Storage (clear water reservoirs, service reservoirs etc.) and Private Storage (Roof, underground tanks in the homes, industries etc).
- The reservoirs are necessary for the following purposes:
 - a. To provide a reserve against failure of main or in intermittent supply system. To meet peak demand by reserving water in other timings. (To balance the fluctuations in the demand)
 - b. To reduce the pressures on the various appliances & installations.
 - c. To economize the size of main pipe. (Reduces pressure then size of pipe)
 - d. To maintain uniform pressure in the distribution system.
 - e. To meet the emergency demands such as fire fighting.
 - f. To use lighter pipes in the distribution system.

7.2 TYPES OF STORAGE TANKS / RESERVOIRS

➤ Reservoirs can be classified in the following ways:

A. According to use:

- a. Clear water reservoir
- b. Service reservoir

a. Clear water reservoir:

- ✓ It is used to store the filtered water until it is pumped or conveyed into the service reservoirs for distribution.
- ✓ The minimum capacity must be 14 - 16 hours average daily flow and it should be divided into two or more compartments to enable repairs or cleaning.
- ✓ The reservoirs are generally built under ground or half below ground level and half above the ground level depending on site conditions.

b. Service reservoir:

- ✓ It is used to store the filtered water from clear water reservoir and constructed before distribution system.
- ✓ These service reservoirs should be designed for balancing storage, breakdown storage and fire storage which will be described later.

B. According to location or position:

- a. Surface / ground / non-elevated reservoir
- b. Elevated reservoir

C. According to materials used:

- a. Earthen reservoir
- b. RCC reservoir
- c. Masonry reservoir
- d. Steel reservoir etc

D. According to the shape:

- a. Circular reservoir
- b. Rectangular reservoir
- c. Spherical reservoir
- d. Egg shaped reservoir

➤ Some commonly used reservoirs are described below:

Storage & Distribution Reservoirs:

Earthen reservoir:

It is the cheapest reservoir used to store large quantity of the water before treatment. It is constructed by excavating to the required depth and the excavated earth is used for embankment for required height. To make the reservoir impermeable core walls and linings of brick or stone or asphalt or concrete etc are done as shown in fig 7.1.

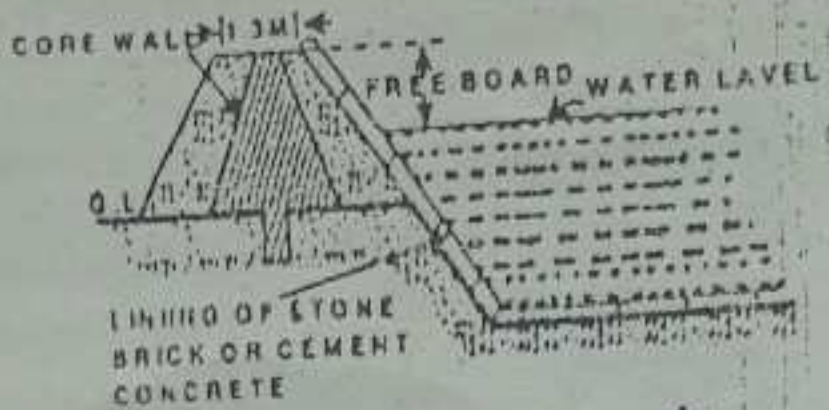

Fig 7.1 Earthen reservoir

Masonry & RCC reservoir:

It is usually constructed underground on high natural grounds to store clear water. It may be constructed of brick, stone, PCC or RCC. A typical masonry surface reservoir is shown in fig 7.2. The sidewall of reservoir is designed to bear water pressure when tank is full and to bear earth pressures when reservoir is empty. The floor is generally constructed of RCC slab and joints are made leak proof with bituminous compounds. The RCC roof resting on number of columns is covered with 50 to 75 mm thick layer of earth with grassy lawn is provided. Ventilations for aeration, stairs for internal access for inspection is provided.

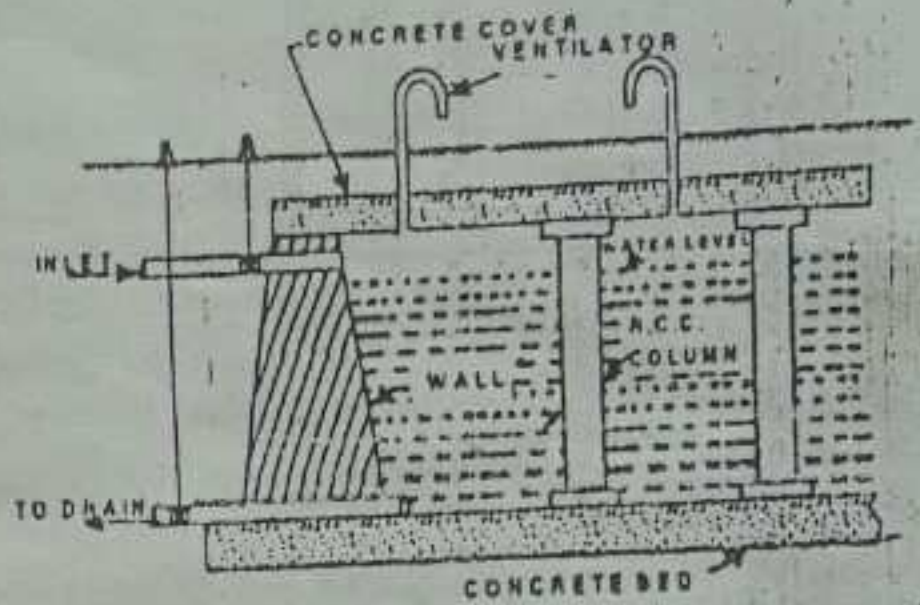

Fig 7.2 A typical masonry surface reservoir

Stand pipe:

Stand pipe is also a elevated reservoir usually constructed of steel (sometimes RCC), circular in plan and up to 15 to 30 m high. The main function of standpipe is to increase pressure in the distribution system by creating extra storage in the tank above the elevation required to give the necessary pressure for distribution. The diameter of these tanks varies from 10 to 15 m. The volume of water stored in the tank above the entrance of the outlet pipe can only be used and hence it is useful storage of standpipe. A typical stand pipe is shown.

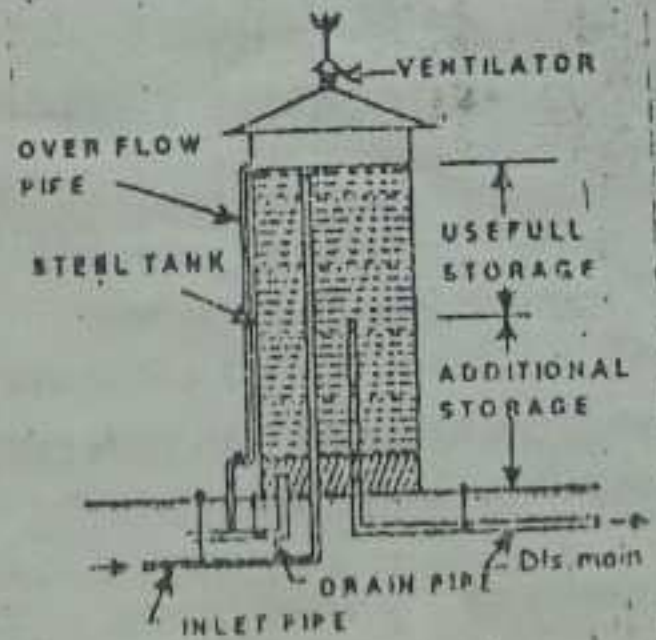

Fig 7.3 Standpipe

Elevated reservoirs:

These are the reservoirs which are constructed at an elevation from the ground level and made of RCC or steel. These are also called overhead tanks and the shapes may be circular, rectangular, egg shaped, spherical, elliptical etc. Any elevated reservoirs consist of inlet, outlet, overflow for air circulation, a water level accessibility, manhole for inspection, ventilator for air circulation, a water level indicator and a lightning rod. Now a days RCC intz tank is very popular. (See fig 7.4)

fig 7.4)

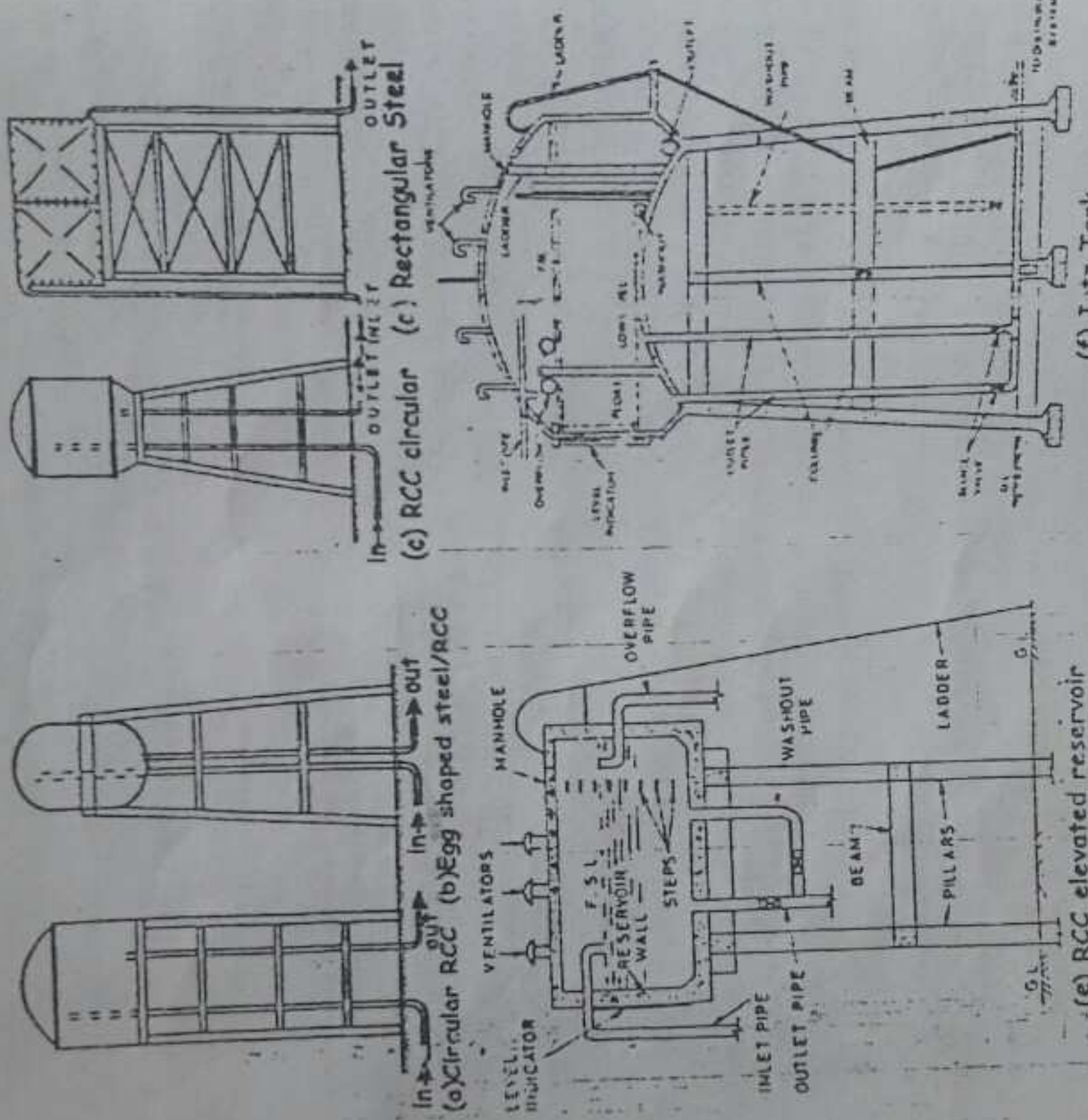

Fig 7.4 Different elevated reservoirs

7.3 CAPACITY CALCULATION OF A BALANCING RESERVOIR

Total Capacity of a Reservoir

$$= \text{Breakdown storage} + \text{Fire storage} + \text{Balancing storage}$$

- A. Breakdown Storage:** (Emergency storage)
- ✓ It is the Emergency storage for emergencies such as the failure of pumps, electricity, or any other equipments and time for repairs.
 - ✓ It is difficult to assess hence generally 25% of the total capacity of the reservoir or about 1.5 to 2 times the average hourly supply may be considered as breakdown storage.
 - ✓ Higher value may be adopted, if the expectation of failure is very high.

- B. Fire Storage:**
- ✓ It is the storage that is required to extinguish fire at the emergencies.
 - ✓ Fire storage is calculated by the following formula $R = [F - P] T$
 Where, R = Fire reserve (liters), F = Fire demand from various formulas (l/min), P = Reserve fire pumping capacity (l/min) and T = Duration of fire (min)
 As per National Board of fire underwriters (America), T is taken as 4hrs, 6 hrs, 8 hrs for community having 1000, 2000, 4000 no of people and for population of 6000 to 2 lakhs, T & F is taken as 1 hr & 10,000 to 50,000 l/min respectively.
 - ✓ Value calculated from the above formula is very high hence in developing countries; about 1 - 5 lpcd is taken for the Fire Storage.

- C. Balancing Storage:** (Equalizing or operating storage)
- ✓ The quantity of water to be stored in the reservoir for equalizing or balancing the fluctuations in the demand against the rate of the supply from treatment plant is called *balancing reserve* or *balancing storage* or *equalizing storage* and the service reservoir designed for this purpose only is called *balancing reservoir*.
 - ✓ There are two commonly used methods to calculate Balancing Storage.
 - (a) Mass curve Method
 - (b) Analytical Method

a. Mass Curve Method:

- We know the mass curve is the plot of cumulative supply (inflow) and cumulative demand (outflow) versus time.
- Procedures:
 1. From previous given or collected data, take hourly demand for 24 hrs in the typical days (max, min & average)
 2. Calculate cumulative demand and cumulative supply and plot mass curve of demand against time & mass curve of supply against time to determine two curves. [Two cases may arise, one is constant rated supply for 24 hrs and the other is constant rated supply during limited time] (See fig 7.5)

3. Now find the two max ordinates (one deficit and other surplus) between demand and supply curve as A & B respectively and calculate Balancing Storage as $(A+B)$. [Sum of A & B is the total ordinate between the two tangents drawn parallel to the supply line.]
4. Repeat the procedure for all typical (min, max & average) days & finalize the max storage capacity for the worst day.

B. Analytical Method (procedures):

1. Calculate the cumulative hourly demand & cumulative hourly supply for 24 hrs in tabular form.
2. Find the hourly excess of demand (deficit), excess of supply (surplus), total demand (TD) and total supply (TS).
3. Then note the maximum cumulative surplus (MCS) and maximum cumulative deficit (MCD).
4. Then the capacity of balancing reservoir (CBR) is given by:
 - a. If $TS > TD$, $CBR = MCS + MCD - TS + TD$ and
 - b. If $TS \leq TD$, $CBR = MCS + MCD$

2.4 SYSTEMS OF SUPPLY

- Water may be supplied to the consumers by the following two systems.
 - (a) Continuous system
 - (b) Intermittent system

a. Continuous system:

- ✓ If water is supplied to the consumers for all 24 hours of a day from a system of supply, it is called the continuous system.
- ✓ It is the best system and has following advantages and disadvantages:

Advantages:

- i. Water is available whenever needed hence no need of private storage tank.
- ii. No stagnant in the pipe at any instant so fresh water is always available.
- iii. Adequate quantity of water is available at any time for fire fighting.

Disadvantages:

- i. More wastage of water if the people do not possess the civic sense and do not understand the importance of water.
- ii. If there is leakage in the system, large volume of water is wasted because of long duration of flow.
- iii. Adequate quantity of water is available at any time for fire fighting.

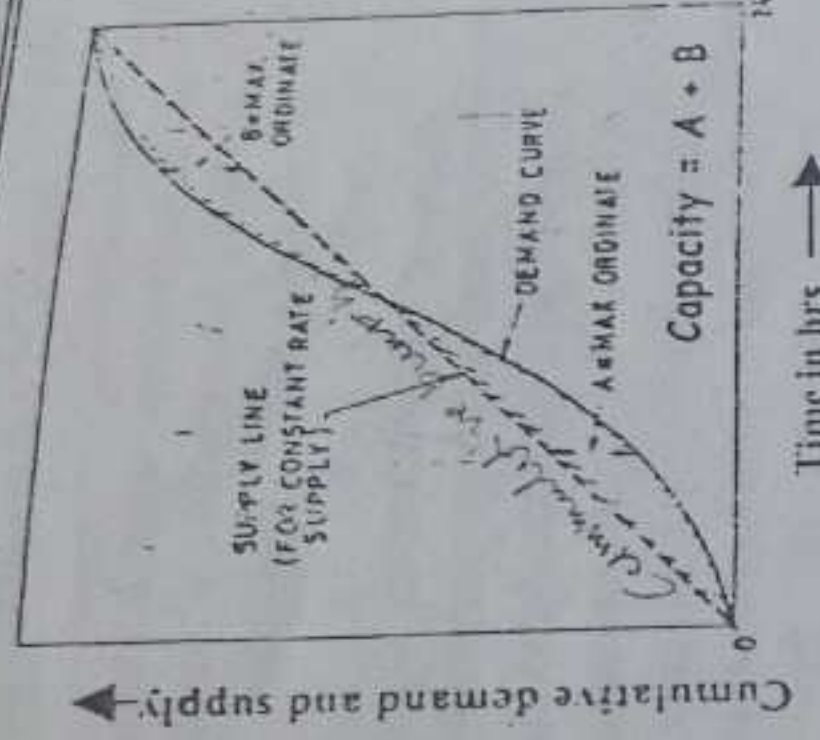

Fig 7.5 Mass curve for reservoir

b. Intermittent system:

- ✓ If water is supplied to the consumers only during fixed hours of a day from a system of supply, it is called the intermittent system. It is the most common system adopted in Nepal.
- ✓ The timing are fixed normally at the morning and evening. Timing may be changed to suit climatic and seasonal condition of the year.
- ✓ Quick steps should be taken to change it into continuous system.
- ✓ This system has following advantages and disadvantages:

Advantages:

- i. Useful when either sufficient pressure or quantity of water is not available at the source to meet the demand.
- ii. At various distribution zones of the city, water can be supplied by turn.
- iii. Repairing work can be done in non supply hours.
- iv. Leakage causes less waste of water because of small duration of flow.

Disadvantages:

- i. In convenience to consumers because they have to remain alert to collect the water during supply periods may be in queue.
- ii. Requires the domestic storage in small tanks in each house to use water for non supply period. Consumers may not have sufficient storage which may causes in-sanitary conditions.
- iii. No water is available for fire fighting in non supply hours and before the system is on, fire may cause huge damage.
- iv. During the non supply time, taps left open unknowingly or due to negligence which led more waste of water.
- v. Greater diameter of pipes is required because full day supply should be done in a short period.
- vi. During non supply time pressure in the line may fall below atmospheric pressure which may induce suction of external matters and soil through leak joints. The pipe line laid nearer sewers may lead severe contamination and pollution.
- vii. Many valves will be required for maintaining the system to open or close and to operate such valves extra staff may be required.

7.5 LAYOUT OF THE DISTRIBUTION SYSTEM

- After conveying water through transmission main from source to treatment plant the treated water is stored at the reservoir to meet the hourly and daily demand.
- This stored water is then distributed through a system consisting of network of pipe line with appurtenances, which is called the distribution system.
- Water through distribution system is taken to the individual house, industries, commercial places, institutions and public places.

Depending upon layout, the distribution system can be classified as follows:

- (a) Dead end or tree system
- (b) Grid iron system
- (c) Circular or ring system
- (d) Radial system

a. Dead end or tree system: (552)

In this system, one main pipeline through the center of the area to be served and from both sides of the main, the sub-mains take off.

The sub-mains are further divided into several branches from which service connections are given to the consumers. (See fig 7.6)

So the entire area is covered by a network of pipe lines running like a branch of a tree and no cross connection is done but various dead ends are available.

- Mostly adopted in towns or cities developed in haphazard way. Eg: Kathmandu valley.
- The system has following advantages and disadvantages:

Advantages:

- i. Easy in calculation of pressure at any point and hence design of pipes, valves and network is easy.
- ii. Pipes are designed only for population likely to be served by them.
- iii. Less numbers of cutoff valves are required.
- iv. Pipe laying is very simple.

Disadvantages:

- i. Accumulation of sediment and stagnation because of dead ends and quality of water is degraded.
- ii. If the system fails by breaking of pipe or closed or repair, whole locality beyond that point can't get water.
- iii. Many scour valves are required and less successful in maintaining satisfactory pressure in the far areas.
- iv. The water available for fire fighting is low because supply can neither be increased nor be diverted.

b. Grid iron system:

In this system, one main pipeline through the center of the area to be served and from both sides of the main, the sub-mains take off in perpendicular direction and branch lines interconnects all sub-mains so that water can circulate through entire distribution system. (See fig 7.7)

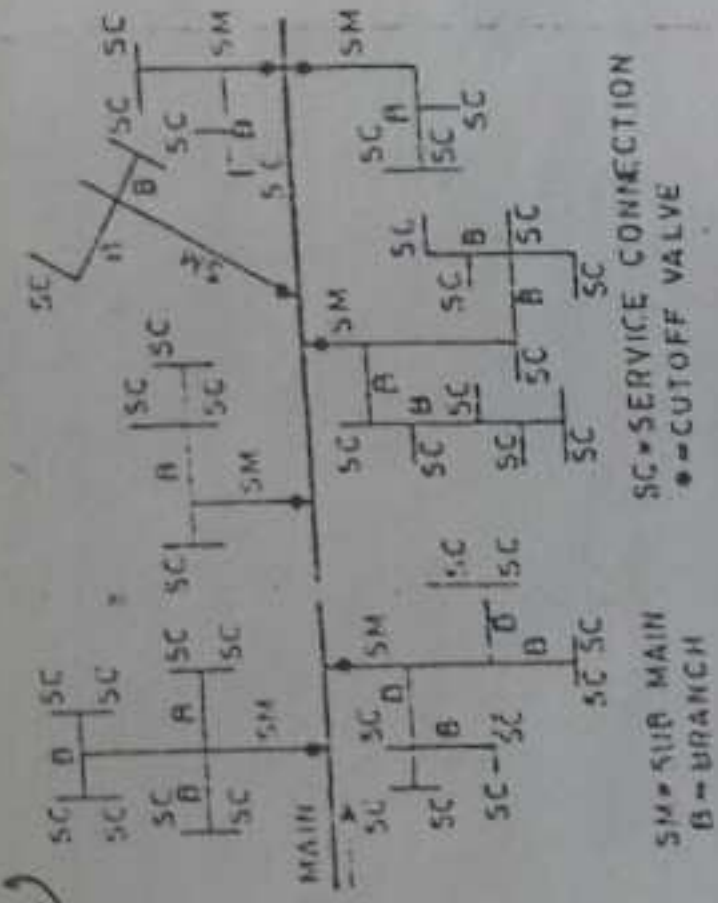

Fig 7.6 Dead end or tree system

- ✓ This system is suitable for cities planned in the rectangular pattern or grid iron pattern.
- ✓ The system has following advantages and disadvantages:

Advantages:

- Circulation of water is available hence no stagnation or sediment deposit and no chance of pollution.
- Due to interconnection, water is delivered at every point of the system with minimum head loss.
- Repair or damage in any section affects only in very small area.
- Fire fighting water can be easily available by diverting the water from the other sections to the affected area using valves.

Disadvantages:

- More number of cutoff valves and longer length of pipes are required and costly in laying.
- Design of pipes and calculation of pressure is laborious, complicated and difficult.
- Overall cost is high.

c. Circular or ring system:

- ✓ In this system, entire distribution area is divided into small circular or rectangular blocks and main pipelines are laid on the periphery of those blocks. Those peripheries of the mains are then linked in the interior of the area as shown in fig 7.8.

- ✓ In this case water at any point is available from any two directions.
- ✓ This system is suitable for cities having well planned roads and roads in circular or rectangular pattern. The length of main pipe is larger and hence large quantity of water is available for fire fighting and all other advantages and disadvantages are as same as in grid iron system.

d. Radial system:

- ✓ In this system, the layout is reverse of circular or ring system. Water flows towards the outer periphery.

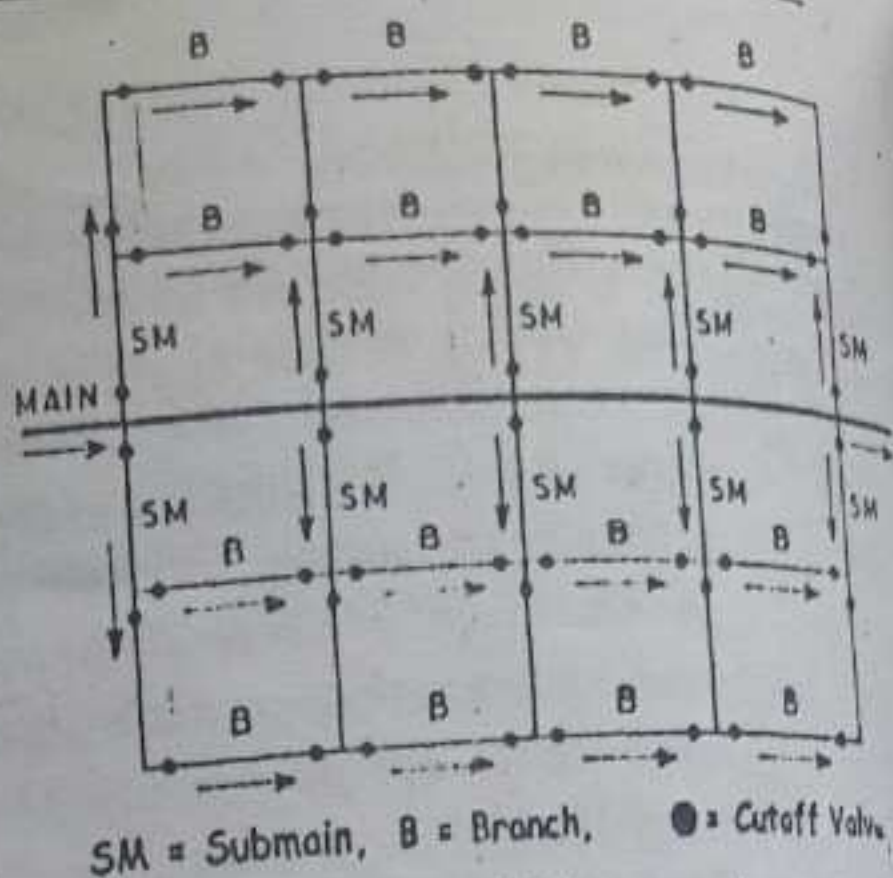

Fig 7.7 Grid iron system

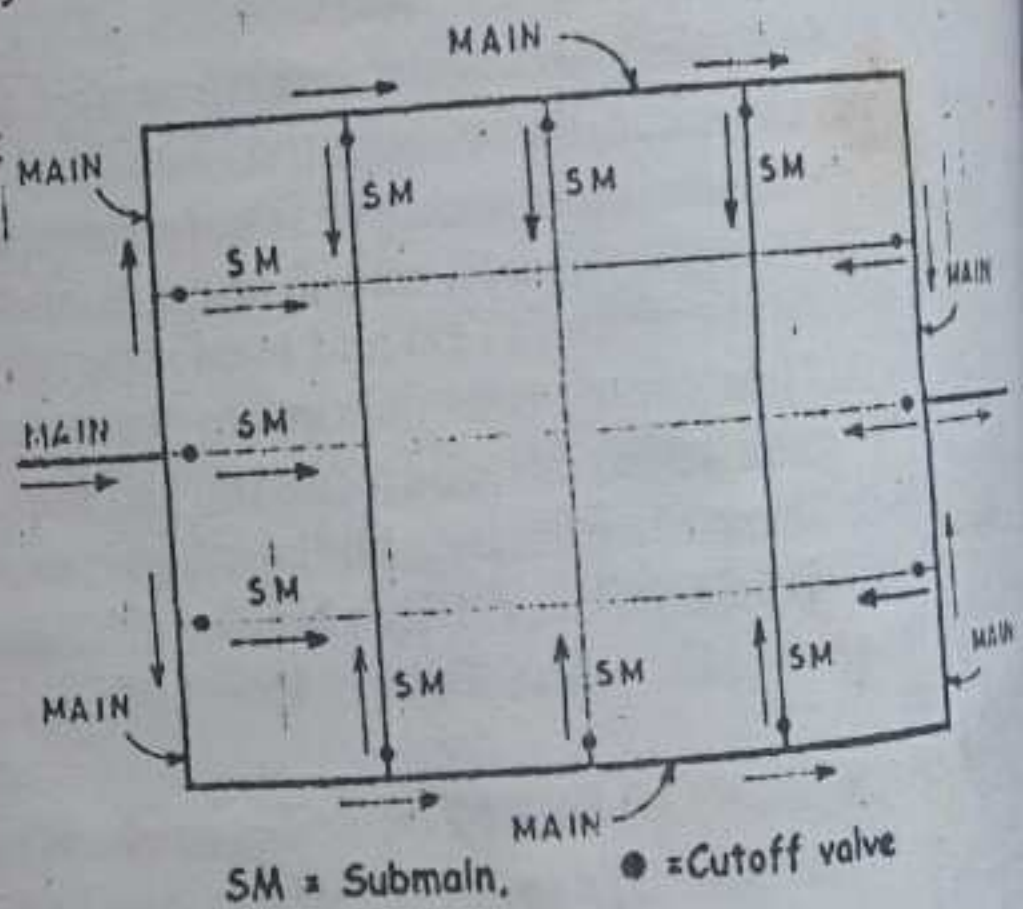

Fig 7.8 Circular or ring system

Water Supply Engineering

the entire distribution area is divided into small circular or

- ✓ In this system the entire distribution area is divided into small circular or rectangular zones and each center of the zone is provided with a distribution reservoir and water is flowed radially towards periphery from branches as shown in fig 7.9.
- ✓ In this system has high pressure of distribution and gives quick and efficient water distribution and hence more efficient in fire fighting.

✓ This system is suitable for cities having radial road network.
 ✓ Major disadvantage of this system is that it requires more reservoirs and all other advantages and disadvantages are as same as in grid iron system.

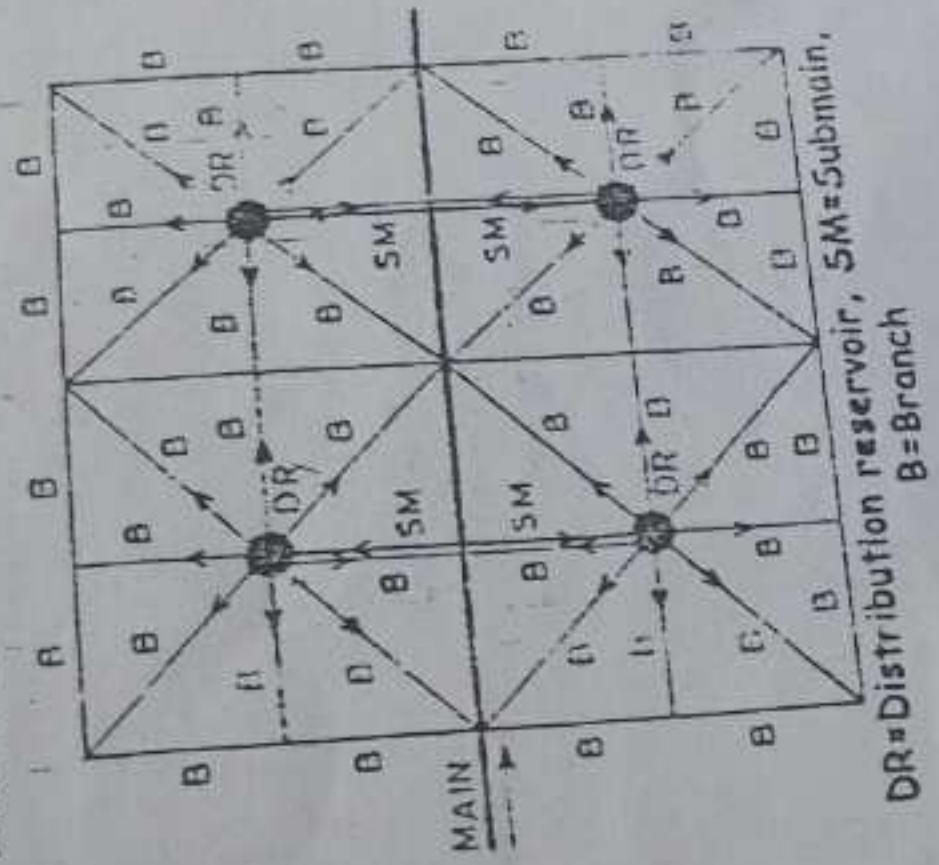

Fig 7.9 Radial system

network adopted in the system.

7.6 DESIGN OF DISTRIBUTION SYSTEM

- ✓ It consists of the design of the pipeline and network
- ✓ For design following points are considered:
 - a. Type of flow (continuous or intermittent)
 - b. Method of distribution (gravity or pumping)
 - c. Probable future demand
 - d. Life of pipes etc.

A. Design steps on distribution system:

1. **Survey and preparation of contour maps and plans:** treatment plant and position of the roads, streets lawns, parks, position of underground service lines (electrical, telephone line, gas, sewer, existing water supply line etc.) are prepared and then studied.
2. **Tentative layout:** Then tentative layout of various zones are marked with the density and tentative layout of mains, sub-mains, reservoirs, valves, hydrants etc are marked.
3. **Calculation of discharge:** Based on the density of the population the discharge is computed on the basis of the population and type of distribution zone and fire demand.
4. **Computation of pipe diameters:** Pipe lines are designed for discharge and required pressure the pipe diameters of demand for this discharge and required pressure the pipe diameters are

Chapter 7. Reservoirs and distribution system

determined using different hydraulic formula. Hazen-Williams formula is more common.

5. Computation of available residual pressure head:

Calculation of residual pressure head (head above GL) available at the end of any point is done knowing head available at the reservoir and head loss up to that point. If the available residual head is lesser or too high, pipe size should be revised.

B. Design Criteria:

1. Discharge:

Discharge should be sufficient to meet the future demand. Pipe lines are designed for 2.5 - 3 times the average demand.

2. Pressure:

Pipelines are designed for sufficient residual pressure so that it reaches to the desired height. The residual head for Single storey is taken as 7 m, two storeys is 12 m and three storey is 17 m and it shouldn't be greater than 22 m above the ground level.

3. Minimum size of pipes:

The lower the diameter the head loss is greater. For population less than 20,000, minimum diameter of distribution pipe is 10 cm and for greater than 20,000 it is 15 cm. For dead end pipes it is 10 cm, for distribution and service pipe 10 cm and 20 mm for house connections but for grid pipes and dead end pipes less than 10 cm may be used.

4. Velocity:

If velocity is low, larger diameter pipes are required and problem of silting may occur. If velocity is high, cost become high in pumping and cost of pipe and fitting will increase to bear extra pressure. On the other hand higher the velocity, smaller the diameter which lead loss of energy is high. Hence, it shouldn't be too low and not too high. It is taken as 0.6 to 3 m/s in pumping and 0.6 to 1.5 m/s for gravity supply.

5. Gradient:

No need of gradient in pressure flow pipes but pipes should be laid below the HGL (hydraulic Grade Line). The gradient of HGL shows the residual head available at any selected point hence high slope of HGL means head loss is high.

C. Pipe Design:

Pipe line design includes:

a. Hydraulic design of pipes:

It is the design of diameter of pipe and concerned in this course.

b. Structural design of pipes:

It includes the thickness of pipe required to withstand internal water pressure, external loads, temperature stress, thrust at bends, flexural strength etc. It is beyond in this course and not described here.

7.7 HYDRAULIC DESIGN OF PIPES

- Hydraulic design of pipes is required to determine the size of the pipes (diameter) between inlet and exit just to carry sufficient amount of water.
- For design of pipes, the following two basic equations of hydraulics are used:

a. Continuity equation:

It is based on the conservation of mass that "mass can neither be created nor be destroyed until and unless nuclear reaction takes place". For one dimensional flow as in fig 7.10, mathematically,

$$Q = AV, Q_1 = A_1 V_1 \text{ and } Q_2 = A_2 V_2,$$

$$Q = Q_1 + Q_2 = A_1 V_1 + A_2 V_2$$

Where, Q, A & V represents discharge, cross sectional area of pipe and velocity respectively and the suffix indicates the pipe section.

b. Bernoulli's equation:

It is based on the principle of conservation of energy that "for any incompressible, steady, ideal, irrotational flow total energy per unit wt. of fluid at any point of flow is constant, provided no energy is added or taken out"

From Bernoulli's equation, for water supply pipe design, the total energy available at the inlet section of the pipe is equated to the sum of the total energy available at the any exit section and head losses (energy losses) from inlet to the exit section. Considering fig. 7.11, Mathematically,

$$z_1 + \frac{p_1}{\gamma} + \frac{v_1^2}{2g} = z_2 + \frac{p_2}{\gamma} + \frac{v_2^2}{2g} + H_L$$

Where,

z = Potential head or potential energy

p/γ = Pressure head or pressure energy

v²/2g = Velocity head or kinetic energy, z = p/γ is called piezometric head.

p = pressure, γ = unit wt of water,

g = acceleration due to gravity,

v = velocity of flow,

H_L = total head loss and the suffix denotes pipe section at 1 and 2.

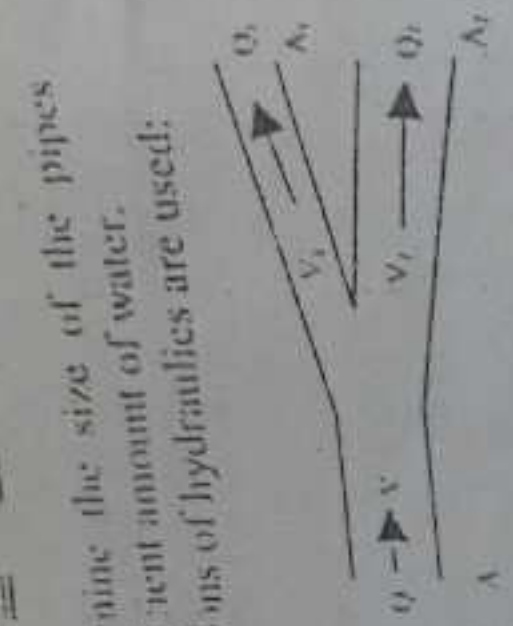
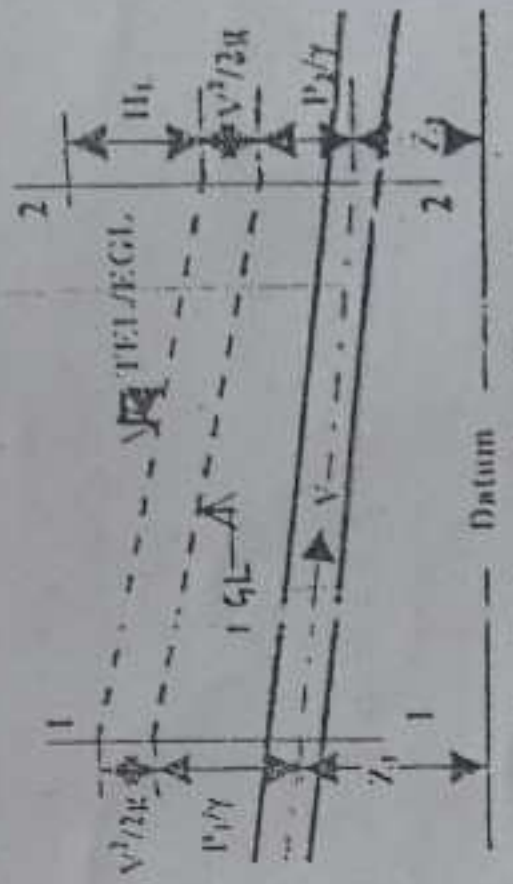

Fig 7.10 A branched pipe



(Note: TEL = Total energy line, HGL = Energy grade line, HGL = Hydraulic grade line. The minor head loss is not shown)

Fig 7.11 Concept of Bernoulli's equation

7.8 HEAD LOSSES IN PIPES (H_L)

When water flows through a pipe, resistance in flow due to friction as well of fittings results the loss of head.

This head loss or energy loss is classified into the following two:

- A. Major Loss (h_f)
- B. Minor Loss (h_m)

The total head loss is the sum of major and minor losses (i.e. $H_L = h_f + h_m$) but in comparison to h_f , h_m are negligible in most of all cases. Then, $H_L = h_f$

A. Major Loss (h_f):

It is the loss of energy or head in pipes due to friction and can be determined by using either of the following:

a. Darcy Weisbach formula:

It is the one of the commonly used formula to determine the major loss in the pipes due to friction. $h_f = \frac{fLV^2}{2gd}$ Also, $Q = AV \Rightarrow V = \frac{Q}{A} = \frac{Q}{\pi d^2/4} = \frac{4Q}{\pi d^2}$

$$\text{So, } h_f = \frac{fL(4Q/\pi d^2)^2}{2gd} = \frac{16fLQ^2}{2 \times 9.81 \times \pi^2 d^5}$$

$$\Rightarrow h_f = \frac{fLQ^2}{12.1d^5}$$

Where,

h_f = Head loss in m, L = Length of pipe in m, d = Diameter of pipe in m
 V = Mean velocity of flow in pipe in m/s $g = 9.81 \text{ m/s}^2$

f = Friction factor (varies from 0.02 for new smooth pipes to 0.075 for older)
 The value of 'f' is determined from various approximate as well as accurate formulas. Mostly pipe flow is turbulent and the following Colebrook and White equation may be used.

$$\frac{1}{f} = -2 \log_{10} \left[\frac{k}{3.7d} + \frac{2.51}{R_e \sqrt{f}} \right]$$

(Note: It is find by Moody's diagram)

Where,

k = Roughness of the pipe material = k_0 (for new pipe) = $k_0 + \alpha t$ for old pipes because for old pipes roughness increases in rate ' α ' with respect to any time ' t ', R_e = Reynold's number = Vd/ν , and ν is kinematic viscosity of water. (Refer any book for value of k)

b. Manning's formula:

This is commonly used for open channels but can be used for pressure flow.

$$V = \frac{1}{n} R^{2/3} S^{1/2} \text{ or } S = \left[\frac{nV}{R^{2/3}} \right]^2 = \frac{n^2 V^2}{R^{4/3}} = \frac{n^2 Q^2}{A^2 R^{4/3}} = \frac{n^2 Q^2}{(\pi d/4)^2 R^{4/3}} = \frac{16n^2 Q^2}{\pi^2 d^4 R^{4/3}}$$

Where,

R = Hydraulic mean depth of pipe in m, S = Slope of the energy grade line or head loss per m length = h_f / L , n = Manning's roughness or rugosity coefficient for pipe material (Refer Tables from any book)

For circular pipe, $R = \frac{A}{P} = \frac{\pi d^2/4}{\pi d} = \frac{d}{4}$, Where, P = Wetted perimeter of pipe

Now, $S = h_f/L$ or, $h_f = SL = \frac{16 n^2 Q^2}{\pi^2 d^4 R^{4.87}} L = \frac{4^{0.87} \times 16 n^2 Q^2}{\pi^2 d^4 \times d^{1.71}} L$

$$\Rightarrow h_f = \frac{10.294 n^2 L Q^2}{d^{1.63}}$$

c. Hazen-William's formula:

This is widely used for design of pipes in water supply systems. According to this formula the mean velocity of flow 'V' is given by:

$$V = 0.849 CR^{0.63} S^{0.54} \text{ or, } S = \left[\frac{V}{0.849 CR^{0.63}} \right]^{1/0.54} = \left[\frac{V}{0.849 CR^{0.63}} \right]^{1.852}$$

Where, C = Roughness coefficient depends upon pipe material and condition of pipe. (Value of C for; New CI = 130, GI = 70, HDPE = 140, Old CI = 100, Refer books) Now, head lost 'h_f' in m can be determined by:

$$h_f = SL = \left[\frac{V}{0.849 CR^{0.63}} \right]^{1.852} L = L \left[\frac{1.354}{0.849 C (d/4)^{0.63}} \right]^{1.852} = \frac{6.825 L}{d^{1.107}} \left[\frac{V}{C} \right]^{1.852}$$

$$\Rightarrow h_f = \frac{6.825 L}{d^{1.107}} \left[\frac{V}{C} \right]^{1.852}$$

$$\Rightarrow h_f = \frac{10.68 L}{d^{4.87}} \left[\frac{Q}{C} \right]^{1.852}$$

Hazen-William's formula is very complex hence it is may be solved by the help of Hazen-William's nomogram which has four variables. If any two of the variables are known a straight line may be plotted and other two can be determined. If nomogram is for C = 100 is available, the head loss is multiplied by a factor X/100 other C = X. It will be discussed in the example problem later.

B. Minor Loss (h_m):

Loss of energy occurs if velocity of flow in the pipe either in the magnitude or the direction changes. If the length of pipe is large the loss of energy due to friction is high than these losses hence it is called minor losses and can be neglected without serious error. Some of the minor losses may be calculated as

1. Loss of energy or head due to sudden enlargement

$$h_m = (V_1 - V_2)^2 / 2g$$

2g

where, V₁ and V₂ are velocities in the smaller and the larger sections and g = 9.81 m/sec²

2. Loss of energy or head due to sudden contraction

$$h_f = 0.5 \frac{V^2}{2g}, \text{ Where } V \text{ is mean velocity in the smaller section of pipe.}$$

3. Loss of energy or head at the entrance

$$h_f = 0.5 \frac{V^2}{2g}, \text{ where } V \text{ is mean velocity of flow in the pipe}$$

4. Loss of energy or head at the exit from a pipe

$$h_f = \frac{V^2}{2g}, \text{ Where } V \text{ is mean velocity of flow at the exit section of the pipe}$$

5. Loss of energy or head due to gradual enlargement or contraction in a pipe

$$h_f = k \frac{(V_1 - V_2)^2}{2g} \text{ where, } V_1 \text{ and } V_2 \text{ are velocities in the smaller and the}$$

larger sections and k is a coefficient depends on the angle of convergence and divergence and the ratio of areas of smaller and larger diameter of pipes.

6. Loss of energy or head at the bend

$$h_f = k \frac{V^2}{2g}, \text{ Where } v \text{ is mean velocity of flow in the bend and } k \text{ is the}$$

coefficient depends on the total angle of bend and relative radius of curvature (R/d) where R is radius of curvature of pipe axis and d is the dia. of pipe.

7. Loss of energy in various pipe fittings such as valves, couplings etc.

$$h_f = k \frac{V^2}{2g} \text{ where } v \text{ is mean velocity of flow in the fitting and } k \text{ is the}$$

coefficient depends upon type of fittings. (Refer any book for value of k)

7.9 DESIGN OF PIPE NETWORKS

Two systems of pipe network arise in the design:

- A. Branched system B. Looped system

A. Branched System:

✓ A branch system is the tree or dead end system as shown in fig 7.6.

✓ This system is conventionally designed as follows.

1. Determine the population served by the each pipe.

2. Knowing the demand and peak factor and population find discharge to be conveyed through each pipe.

3. Assume pipe diameter of each pipe section considering design criteria.

4. Calculate the head loss in each pipe section using the head loss formula. (Generally Hazen-William's formula is used in w/s pipe design)

5. Check residual pressure and velocity as per design criteria. Adopt the diameter if pressure and velocity is within allowable limits otherwise recalculate choosing the diameter of pipe

B. Looped system:

- ✓ Looped system consists of pipe loops which are in complex system. The loop may contain various pipes in series and parallel.
- ✓ There are various methods for analysis and design of such looped network but the following are the commonly used methods:

a. **Equivalent pipe method:**

- This method is based on the principle that any complex pipe system can be replaced by a single hydraulically equivalent pipe with equal head loss for a given flow.

- Let us consider a loop of pipe network as shown in fig 7.12. Portion ABD consists of AB & BD in series and portion ACD consists of AC & CD in series whereas ABD & ACD portion are in parallel. Q, d and L with suffix represents the discharge, diameter and length of respective pipes.
- The analysis of this network can be done considering the following two hydraulic axioms.

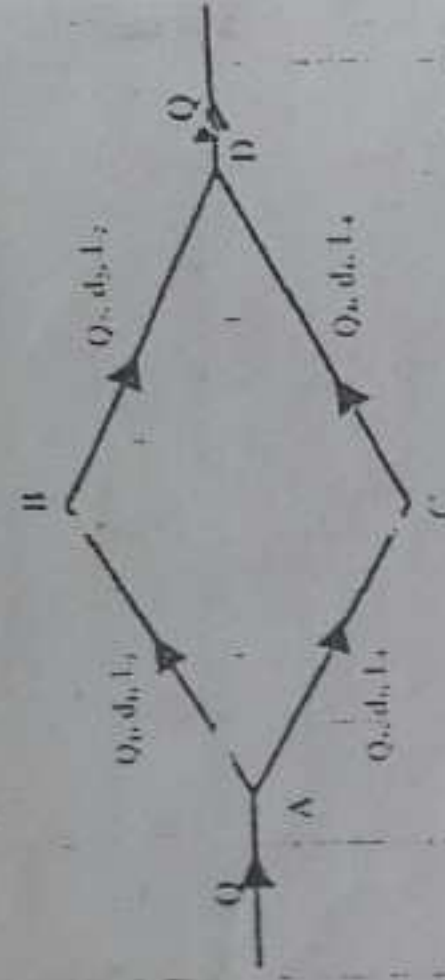

Fig 7.12 Concept of equivalent pipe method

- i. Head loss through pipes in series are additive;
- ii. Head loss through parallel pipes must be distributed in such a way that the head losses are identical.

Pipes in series:

Consider ABD portion with AB & BD pipes in series and let the equivalent pipe of length L_e and diameter d_e for these pipes in series. Then head loss is additive and given by

$$(h_f)_{ABD} = (h_f)_{AB} + (h_f)_{BD} \text{ but } h_f = \frac{10.681}{d^{4.87}} \left[\frac{Q}{C} \right]^{1.852} \text{ as per Hazen-William's}$$

formula. Then,

$$\text{So, } \frac{10.70 L_e}{d_e^{4.87}} \left[\frac{Q_1}{C} \right]^{1.852} = \frac{10.70 L_1}{d_1^{4.87}} \left[\frac{Q_1}{C} \right]^{1.852} + \frac{10.70 L_2}{d_2^{4.87}} \left[\frac{Q_1}{C} \right]^{1.852}$$

$$\text{Or, } \frac{L_e}{d_e^{4.87}} = \frac{L_1}{d_1^{4.87}} + \frac{L_2}{d_2^{4.87}} \text{ or, } L_e = d_e^{4.87} \left[\frac{L_1}{d_1^{4.87}} + \frac{L_2}{d_2^{4.87}} \right]$$

Generalizing,

$$L_e = d_e^{4.87} \left[\frac{L_1}{d_1^{4.87}} + \frac{L_2}{d_2^{4.87}} + \dots \right] \text{ for pipes in series}$$

Pipes in parallel:

Consider ABD & ACD portion pipes in parallel and let the equivalent pipe of length L_e and diameter d_e for these pipes in parallel. Then the head loss is identical and given by,

$(h_f)_{AD} = (h_f)_{AB} + (h_f)_{BD} = (h_f)_{AC} + (h_f)_{CD}$, then using Hazen William's formula,

$$\frac{10.70L_1}{d_1^{4.87}} \left[\frac{Q_1}{C} \right]^{1.852} + \frac{10.70L_2}{d_2^{4.87}} \left[\frac{Q_1}{C} \right]^{1.852} = \frac{10.70L_e}{d_e^{4.87}} \left[\frac{Q_1}{C} \right]^{1.852} + \frac{10.70L_4}{d_4^{4.87}} \left[\frac{Q_1}{C} \right]^{1.852}$$

$$\text{or, } \left[\frac{Q_1}{C} \right]^{1.852} \left[\frac{L_1}{d_1^{4.87}} + \frac{L_2}{d_2^{4.87}} \right] = \left[\frac{Q_1}{C} \right]^{1.852} \left[\frac{L_e}{d_e^{4.87}} + \frac{L_4}{d_4^{4.87}} \right]$$

$$\text{or, } \left[\frac{Q_1}{Q_2} \right]^{1.852} = \left[\frac{L_1}{d_1^{4.87}} + \frac{L_4}{d_4^{4.87}} \right] \bigg/ \left[\frac{L_e}{d_e^{4.87}} + \frac{L_2}{d_2^{4.87}} \right] = X \text{ (say)} \therefore Q_1 = Q_2 X$$

Again, $Q = Q_1 + Q_2 = Q_2(X+1)$

If the length and diameter of equivalent pipe causing same head loss between A and D are L_e and d_e then,

$(h_f)_{AD} = (h_f)_{AC} + (h_f)_{CD}$, then using Hazen William's formula we get,

$$\frac{10.70L_e}{d_e^{4.87}} \left[\frac{Q}{C} \right]^{1.852} = \frac{10.70L_3}{d_3^{4.87}} \left[\frac{Q_2}{C} \right]^{1.852} + \frac{10.70L_4}{d_4^{4.87}} \left[\frac{Q_2}{C} \right]^{1.852} \text{ or,}$$

$$\text{or, } \frac{L_e}{d_e^{4.87}} (X+1)^{1.852} = \left[\frac{L_3}{d_3^{4.87}} + \frac{L_4}{d_4^{4.87}} \right]$$

$$\text{or, } L_e = \frac{d_e^{4.87}}{(Q_1/Q_2 + 1)^{1.852}} \left[\frac{L_3}{d_3^{4.87}} + \frac{L_4}{d_4^{4.87}} \right]$$

b. Hardy cross method:

It is an trial and error method based on the following three laws:

- i. In each separate pipe there is a relation between head loss and discharge. (i.e. $h_f = r Q^n$)
- ii. At each junction the algebraic sum of the discharge entering and leaving is zero. (i.e. $\sum Q = 0$)
- iii. In any closed circuit of pipes the algebraic sum of head loss (clockwise & anticlockwise) in the individual pipe is zero. (i.e. $\sum h_f = 0$)

The analysis of pipe network by Hardy Cross method is carried out by any one of the following two methods:

- (a) Balancing heads (by correcting assumed flows)
- (b) Balancing flows (by correcting assumed heads)

Water Supply Engineering

(a) Balancing heads (by correcting assumed flows):

It is the original commonly used Hardy Cross method and useful when the quantity of water entering and leaving in the network is known. In this method, loss of heads in the loop is made balance by the correction of assumed flows.

Let, Q is correct flow and Q_0 is the assumed flow in the pipe under consideration. Then, $Q = Q_0 + \Delta Q$, where, ΔQ is the flow correction.

If h_f is head loss in pipe under reference then, $h_f = r Q^n$, where k is a constant.

$$\text{Then, } h_f = r(Q_0 + \Delta Q)^n = r(Q_0^n + nQ_0^{n-1}\Delta + \dots + \Delta Q^n)$$

Since ΔQ is small compared to Q_0 , then neglecting the higher order terms after

$$\text{second one we get, } h_f = r(Q_0^n + nQ_0^{n-1}\Delta Q)$$

$$\text{Also, for a closed network of pipe } \sum h_f = 0$$

$$\Rightarrow \sum r(Q_0^n + nQ_0^{n-1}\Delta Q) = 0 \text{ or, } \Delta Q \sum r n Q_0^{n-1} = - \sum r Q_0^n$$

$$\text{or, } \Delta Q = - \frac{\sum r Q_0^n}{\sum r n Q_0^{n-1}} = - \frac{\sum h_f}{n \sum (h_f / Q_0)}$$

For Darcy Weisbach formula $n = 2$ and for Hazen-William's formula $n = 1.852$

Steps can be summarized as:

1. Assume suitable Q_0 in each pipe so that $\sum Q_0 = 0$ (inflow +ve & outflow -ve) in a junction.
2. Compute h_f in each pipe considering $h_f = r Q^n$ (h_f +ve for clockwise Q_0 and -ve for anticlockwise Q_0 in the loop)
3. If $\sum h_f = 0$, assumed flows ' Q_0 ' are ok. If not find *flow correction* by,
$$\Delta Q = - \frac{\sum h_f}{\sum r n Q_0^{n-1}} = - \frac{\sum h_f}{n \sum (h_f / Q_0)}$$

4. For common pipes in the two loops correction from both loops is required.

5. Other trials with corrected flow are required till ΔQ is negligible.

(b) Balancing flows (by correcting assumed heads): (Not in our course)

It is the modification of original Hardy Cross method and relatively less common but useful when the quantity of water in the network is unknown and there are several inlets. In this method, flows at each junction are made balance for assumed heads at the junction and the corresponding head losses in the pipes.

Steps can be summarized as:

1. Assume head at all free junctions such that $\sum h_f$ in clockwise direction

Chapter 7. Reservoirs and distribution system

2. h_f is +ve for flows towards junction and -ve if flow is away from junction
3. Compute Q in each pipe from $h_f = r Q^n$ giving the same sign as for h_f
4. If $\sum Q \neq 0$, assumed heads are ok. If not find head correction by,

$$\Delta h_f = -n \frac{\sum h_f^{1-n}}{\sum h_f^{1-n}} = -n \frac{\sum Q}{n \sum (Q/h_f)}$$

For Darcy Weisbach formula $n = 2$ and
for Hazen-William's formula $n = 1.852$

5. For common pipes in the two loops correction from both loops is required.
6. Other trials with corrected h_f are required till $\sum Q$ at free junction ≈ 0 .

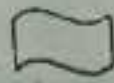

CHAPTER 8 CONVEYANCE OF WATER

8.1 INTRODUCTION

- After collection of water from intake it is conveyed to treatment plant or reservoir or distribution through conduits.
- Conveyance from intake to treatment plant and treatment plant to reservoir is called transmission and reservoir to consumers tap is called distribution.
- If the source is at the higher elevation, it can be conveyed through conduit under gravitational force otherwise pumping is required.
- **Conduit:** It is the device used to carry water. In the ancient times water is conveyed through open channels or wooden log channels. Slowly the use of masonry chamber of rectangular and circular are introduced and then these open channel was closed from top. Normally conduits can be classified into:
 - (a) Gravity conduit
 - (b) Pressure conduit

(a) Gravity conduit:

These are the conduits in which water flows under the action of gravity and there is a free water surface exposed to the atmosphere (open channel flow). Eg: Canals, aqueducts, tunnels etc.

(b) Pressure conduit:

These are the conduits where water can flow under pressure. Eg: pipes, pressure tunnels, pressure aqueducts etc. Pressure conduits can follow the natural ground surface and can be taken up and down hills with in the HGL hence lesser length of conduit is achieved. Pipes types of conduits are heavily used and these are described here.

8.2 PIPES, PIPE MATERIALS AND PIPE TYPE

- Pipes are the circular conduits in which water flows under pressure. Hence they should be designed to resist the internal water pressure and external pressure due to soil and other imposed loads.
- Pipes are made of cast iron, wrought iron, steel, cement concrete, asbestos cement, timber, plastic etc.
- The selection of pipe material depends upon its carrying capacity, durability and life, type of water to be conveyed, its possible corrosive effect, availability of fund, maintenance and repair cost etc.
- **Requirements of a good Pipe:**
 - a. It should be able to withstand external and internal stresses as well as temperature stresses.
 - b. It should be smooth for minimum friction and durable (long life and long lasting).
 - c. It should be light, non-corrosive and cheap

Chapter 8. Conveyance of Water

As per material types pipes are classified as:

- (a) Cast iron (CI) pipes
- (b) Wrought iron (WI) pipes
- (c) Steel pipes
- (d) Galvanized iron (GI) pipes
- (e) Concrete Pipes
- (f) Plastic Pipes
- (g) Asbestos cement (AC) pipes
- (h) Wooden pipes
- (i) Vitrified clay Pipes
- (j) Lead and copper pipes

مصحوب المادة، 06/2/22

1. Cast iron (CI) pipes:

- ✓ It is made of CI and high resistant to corrosion has 100 years life.
- * *Advantages:* Easy to join, can withstand high pressure, resistance to corrosion, long life (> 100 yrs), durable, strong and moderate in cost.
- * *Disadvantages:* Brittle and very heavy so difficult to transport and may be expensive.
- ✓ Suitable for distribution system.

2. Wrought iron (WI) pipes:

- ✓ WI pipes are manufactured by rolling the flat plates of metal to proper diameter and welding to the edges.
- ✓ It is made of WI and can be joined by couplings or screwed socket joint.
- * *Advantages:* Light in weight, easy in transport, handling, cutting, threading, working, joining, and gives neat appearance.
- * *Disadvantages:* Costly, corrosive and less durable than CI pipes.
- ✓ Suitable for inside plumbing in buildings but not used nowadays due to high cost.

3. Steel pipes:

- ✓ Constructor similar to the WI pipes (i.e. flat plates rolled and welded) and can be joined by riveting or welding. Life is 25 - 30 years.
- * *Advantages:* Strong, light weight, can withstand high pressure (400 m) and cheaper than CI pipes
- * *Disadvantages:* Can't withstand external load when there is no water inside, liable to corrosion and costly to maintain. It is costlier than CI pipes.
- ✓ Occasionally used for main lines where pressure is high and diameter is more and not used in distribution system.

4. Galvanized iron (GI) pipes:

- ✓ Made of WI or mild steel which are galvanized by providing a protective coating of zinc on inner and outer surface of pipe.
- ✓ It can be found in 12 - 25 mm diameter and 7 m in length. Also larger sizes can be manufactured in smaller length.
- * *Advantages:* It is cheap, light, easy in handling and transport, easy in joining with screwed socket joints and 20 years of life.

Water Supply Engineering

- * ✓ *Disadvantages:* It may get corroded by acidic and alkaline waters and liable to incrustation.

e. Concrete Pipes:

- ✓ Made of cement concrete (precast or cast in site) and can be joined with bell and spigot joints. PCC are up to 60 cm diameters and used where pressure is less than 15 m of water and for diameter greater than 60 cm, RCC should be used.
- ✓ Precast concrete pipes are manufactured in factory in controlled conditions where as cast in site type can be casted in site using local materials. It can withstand 150 m head of water.
- * ✓ It can resist corrosion and life is above 75 years, maintenance cost is low, least thermal expansion, can be laid under water and resist normal traffic load.
- * ✓ Precast type is heavy to handle and transport, concrete pipes can't resist high pressure and difficult to repair, it may be affected by acids and alkali and salty waters, difficult to join and liable to leak due to porosity.
- ✓ Normally cement, sand and aggregate in 1:2:2 is used for making concrete pipes.
- ✓ In market various sizes ranges from 80 - 1200 mm internal diameter is available.
- ✓ Generally used in such place where water does not flow under pressure (i.e. sewerage system).

f. Asbestos cement (AC) pipes:

- ✓ It is made of mixture of cement and asbestos fibers, manufactured in 5 to 130 cm diameter, resists internal pressure of 3.5 kg/cm^2 pressure.
- * ✓ *Advantages:* It is not affected by salt water and corrosive material. It remains smooth. It is light so easy in handling.
- * ✓ *Disadvantages:* It is affected by alkali and acid and also brittle so costlier in transport.
- ✓ Suitable for small size distribution pipes.

g. Plastic Pipes:

- ✓ It is very common nowadays and heavily used in Nepal because it is corrosion resistant, light in weight and economical.
- ✓ It is not used for transporting hot water.
- ✓ There are various types of plastic pipes:
 - Low density polyethylene (LDPE) pipes:*
 - These pipes are flexible, found up to 63 mm outer diameter.
 - This pipe requires support closer due to flexibility.
 - Used in long runs (eg: point to point conveyance) and not suitable for installation of internal water supply.

ii. *High density polyethylene (HDPE) pipes:*

- These pipes are Tough than LDPE, up to 1600 mm can be manufactured. Outer diameter of 25 to 90 mm is used in rural water supply in Nepal.
- Cheap in cost than other, durable (life 50 years), smooth, resists corrosion, light and easily jointed and bent. Different diameter to resist 4, 6 and 10 kg/cm² can be found.
- It is not suitable for hot water supply.
- Heavily used in rural water supply in Nepal.

iii. *Polyvinyl chloride (PVC) pipes:*

- These pipes can be jointed easily by using fittings and three times rigid than polyethylene, strong in resisting pressure.
- It can resist inorganic acids, alkalis, salts and organic chemicals.
- Used in external and internal cold water supply system, water mains, rainwater pipe, waste pipe etc.

h. *Wooden pipes:*

- ✓ It is made of wood by making channels or boring at center and used in ancient times.
- ✓ Not used in water supply nowadays.

i. *Vitrified clay Pipes:*

- ✓ It is made of vitrified clay so has smooth surface.
- ✓ Not used in water supply but used for convey sewage as open channel flow (flow not full).

j. *Lead and copper pipes:*

- ✓ Copper pipe is made of copper and can resist corrosion even if water contains some acids, it can be easily bent and do not sag in case of hot water supply. It is expensive so used only in making goose neck in house connection and for carrying hot water inside buildings.
- ✓ Leads are soluble in water so caused lead poisoning hence lead pipe is not used in water supply nowadays.

8.3 LAYING OF PIPES

The various operations involved in the laying of pipes are as indicated below:

✓ Preparation of detailed maps:
Detailed survey is conducted

and of detailed map showing the alignment of pipe line from source to treatment plant or to other distribution network is prepared. The map should consist of position of roads, underground sewer, existing pipe lines, gas pipes, telephone lines, electric lines etc

- Locating proposed alignment of pipeline on the ground:
Mark the alignment in the ground by driving central stakes 30 m apart on straight reaches and 7.5 to 15 m apart on curves. On roads just marking is done.
- Location of pipes with respect to ground surface during laying:
Pipes may be laid above ground from source to treatment plant and distribution mains and pipes are laid below the ground surface. Pipes if laid on ground surface, they must be laid on a well compacted surface to avoid future settlement and a small masonry or concrete support at 5 to 15 m is required. If underground laying is done trench is excavated as described below.
- Excavation of trench:
It is done manually in Nepal. The width depends upon the external diameter of pipe (i.e. Width of trench = (30 to 45) cm + external diameter of pipe). Depth of the crown of the pipe should be minimum 90 cm below the ground level to withstand traffic loads. More excavation (15 to 20 cm) width and depth is needed at the joints position. Excavated soil is deposited only at one side of trench and other side is left for pipes. Sign "Men at work" is put before working. Timbering of trench is required for soft soil to prevent caving. In case of rock cutting the bottom of trench is made smooth.
- Dewatering of trench:
When GWT is high dewatering of trench with pump or other means is needed.
- Lowering the Pipes:
The stacked pipes in one side of trench are cleaned to remove external material and gently lower the pipes into the trench so as not to damage protective coatings and ends of pipe.
- Joining pipes:
Using proper joints join pipes along lying. It should be noted that the valves are placed at the proper place or not.
- Testing of pipes:
After laying and joining, pipes are tested for non leakage along a section of 500 m length. For this one end is closed and from another end water is pumped with double of working pressure and it is kept for 24 hours. It is satisfactory if the leakage is not greater than permissible limits given by the following formula.

$$Q = \frac{ND \sqrt{P}}{3.3}$$

- Where:
- Q allowable leakage in cm^3/hr .
 - N No. of joints in the tested stretch.
 - D diameter of pipe in mm and
 - P average test pressure during test in kg/cm^2 .

➤ Back filling and disinfection before first use:

If the tested section is acceptable then back filling of the trench with the excavated earth is done up to 15 cm above the normal ground level. Similarly other sections are tested and backfilled. Before first use, the pipelines should be disinfected using 50 ppm of chlorine added to in pipe maintained with full water for 12 hrs.

4 PIPE JOINTS (475)

➤ For ease in handling and transportation and placing in position, pipes are manufactured in small length of 2 - 6 m. So the pipes should be joined together after placing in the position for continuation. A device required to join the pipe is called the pipe joint. Hence proper joint should be used as per condition, material of pipe, internal water pressure and condition of support.

➤ Following type of joints are commonly used in water supply pipe lines:

- (a) Spigot and socket joint
- (b) Flanged joint
- (c) Expansion joint
- (d) Collar joint
- (e) Screwed and socket joint
- (f) Mechanical joint
- (g) Flexible joint
- (h) AC pipe joint

a. Spigot and socket joint (bell or socket joint):

- ✓ This is used for CI pipes. (See fig 8.1)
- ✓ At joining, spigot of one end of a pipe is slipped in socket or bell end of other pipe and yarn or hemp is wrapped around spigot tightly up to 5 cm depth and a gasket or joint runner is clamped in place of round joint to fit tightly.
- ✓ Now the molten lead is poured into the V shape opening left on the top by clamped joint runner. Now the space between the top of yarn and clamp runner is filled with molten lead.
- ✓ Now the runner is removed after hardening of lead and again tightened by chalking tool and hammer.
- ✓ About 3.5 kg to 4 kg lead is required up to 150 mm diameter pipes and 40 to 45 kg for 120 cm diameter pipe per joint.
- ✓ The cost is high but makes perfect joint.

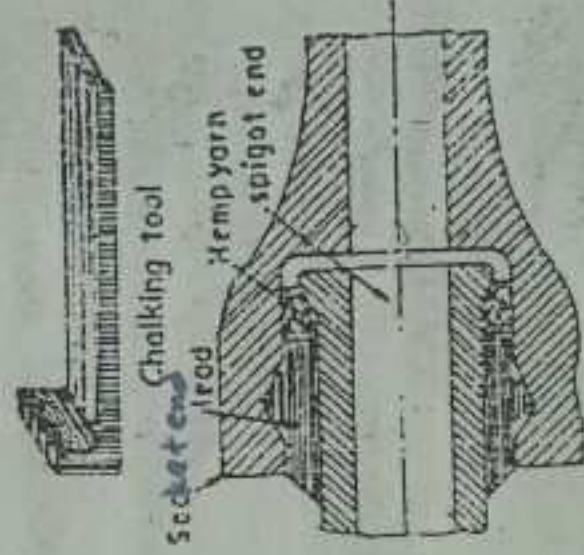

Fig 8.1 Spigot & socket

➤ Fig 8.1 Spigot & socket

b. Flanged Joint:

- ✓ It is used for temporary pipe lines of CI, GI, W1 and steel pipes because it is easy to dismantle and reassemble. (See fig 8.2)
- ✓ In this case, both pipes have flange at both ends or flanges can be screwed or welded.

Water Supply Engineering

- ✓ The flanges are brought together and one hard rubber washer is placed between flanges then bolted for water tightened.
- ✓ These joints are not used at vibration and deflection places. It is suitable for pumping station filter plant, laboratories and boiler house.

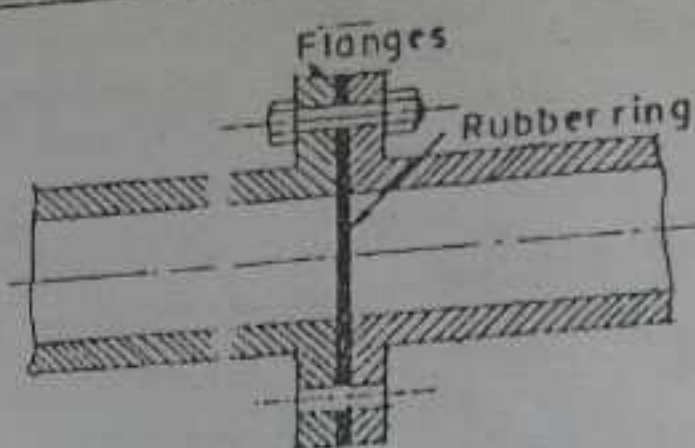

Fig 8.2 Flanged joint

c. Expansion joint:

- ✓ It checks the settling due to thermal stress and so used in the place where pipes expands or contracts due to change in temperature. (See fig 8.3)
- ✓ In this joint, socket end of flanged with CI follower ring which can be freely slide on the spigot end and an elastic rubber gasket is tightly passed between annular space of socket and spigot by means of bolt.
- ✓ When pipe expands socket end moves forward in the space provided and moves backward if contracts.
- ✓ Elastic rubber gasket keeps joint water tight.

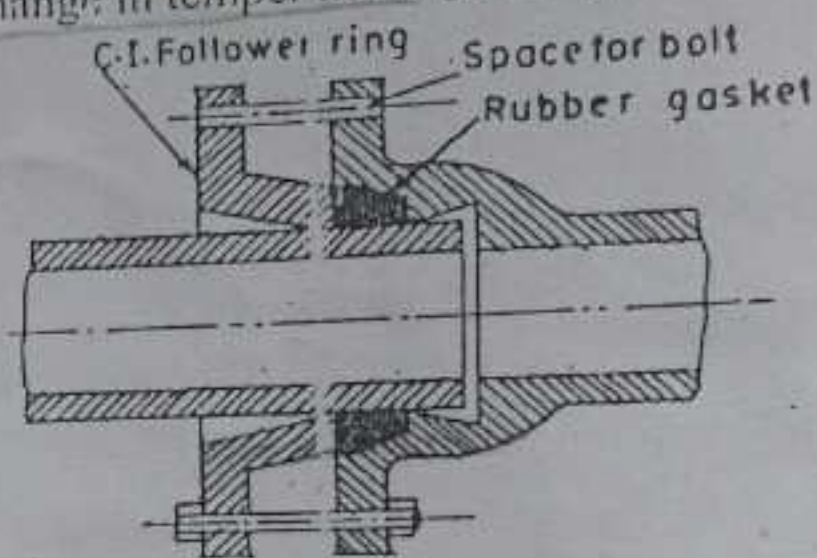

Fig 8.3 Expansion joint

d. Collar joint:

- ✓ Most commonly used for joining concrete and asbestos cement pipes. (See fig 8.4)
- ✓ For joining the pipe with this joint, two ends of pipe is brought in one level and rubber gasket is placed between steel rings or jute rope soaked in cement is kept on groove and collar is placed so that some lap on both pipes is remained.
- ✓ Now 1:1 cement mortar is filled between the space of collar and pipe.

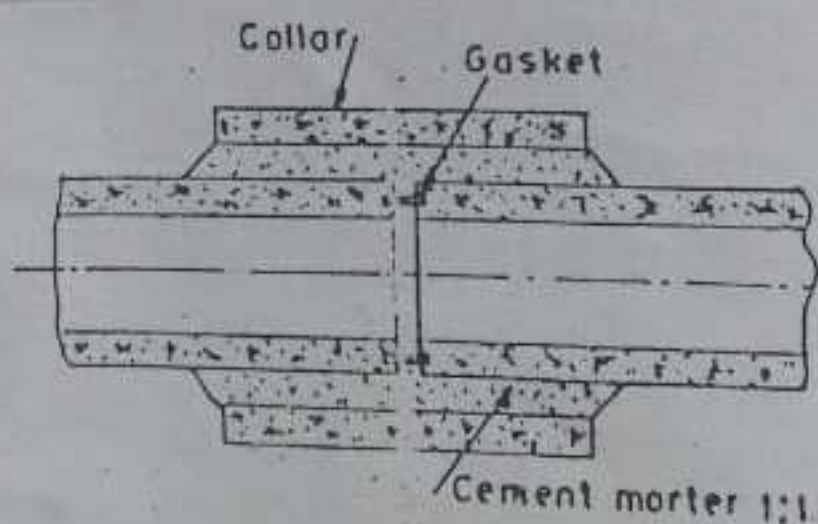

Fig 8.4 Collar joint

e. Screwed and socket joint:

- ✓ This joint is used for small diameter CI, WI and GI pipes for internal plumbing.

Both pipe end have threads and socket is screwed to connect them.

- ✓ Both pipe end have threads and socket is screwed to connect them. (See fig 8.5)

f. Mechanical joint:

- ✓ It is used in C.I. steel or W.I pipes when both end are plain or spigot. (See fig 8.6)
- ✓ Dresser coupling mechanical joint is used in water supply over bridges to bear vibrations.

g. Flexible joint or bell and socket or universal joint:

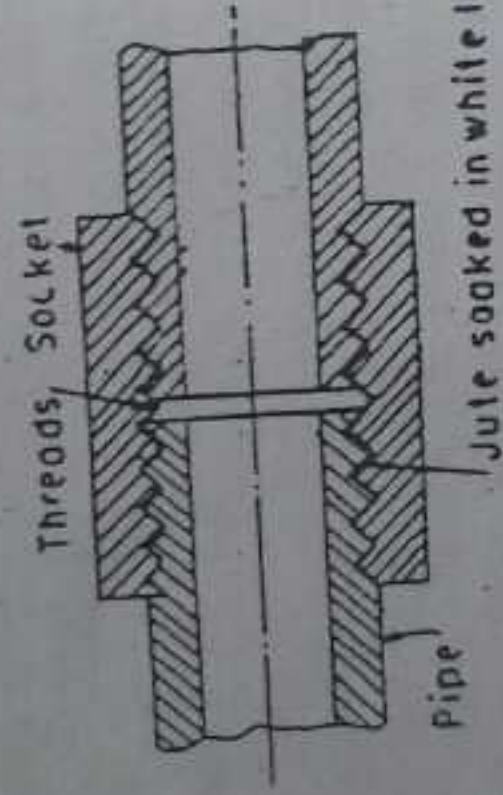

Jute soaked in white lead

Fig 8.5 Screwed & socket joint

- ✓ This joint is used where settlement is likely because it is flexible.

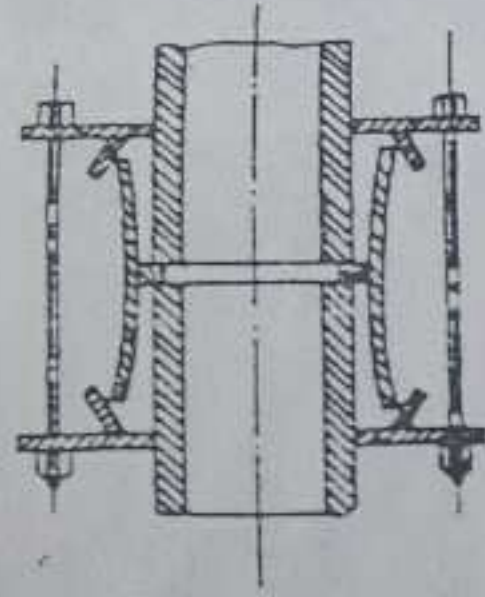

Fig 8.6 Mechanical joint

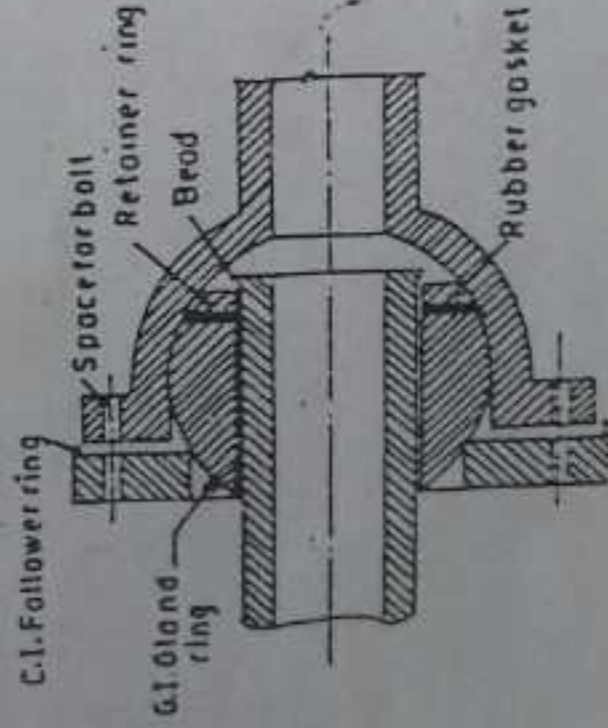

Fig 8.7 Flexible joint

(See fig 8.7)

h. AC pipe joint:

- ✓ It is used for small diameter AC pipes. (See fig 8.8)
- ✓ In this joint, butt ends are put against each other and two rubber rings will be slipped over the pipes and coupling is pushed.
- ✓ Rubber rings makes leak proof.



Fig 8.8 AC pipe joint



CHAPTER 9 VALVES AND FITTINGS

9.1 IMPURITIES IN WATER

- Various devices are used in water supply systems to control the flow of water, to regulate pressures, to release air, to prevent back flow and for other purposes. These devices are called valves.
- Similarly, various devices are used in water supply systems to connect pipes as well as in the outlet indoor or outdoor to get water. These devices are called fittings.

9.2 VALVES

Different valves are available for different purpose which are as follows:

- | | |
|--------------------------------------|---|
| (a) Sluice or gate or cutoff valve | (b) Reflex or check or non-return valve |
| (c) Safety or pressure relief valve | (d) Air valve or air relief valve |
| (e) Drain or scour or blow off valve | (f) Butterfly valve and globe valve |

a. Sluice or gate or cutoff valve: *shot off*

Sluice valves are the commonly used valve to regulate the flow in the pipe and provided at every junction and at the interval of 3 to 5 km. (See fig 9.1)

It is cheaper, offer less resistance to flow, less head loss than other valves of same purposes.

Sluice valve consists of a small chamber in which a circular wedge at the center is placed and this is further connected to the handle which can be rotated for upward and downward movement of wedge to regulate and control the flow.

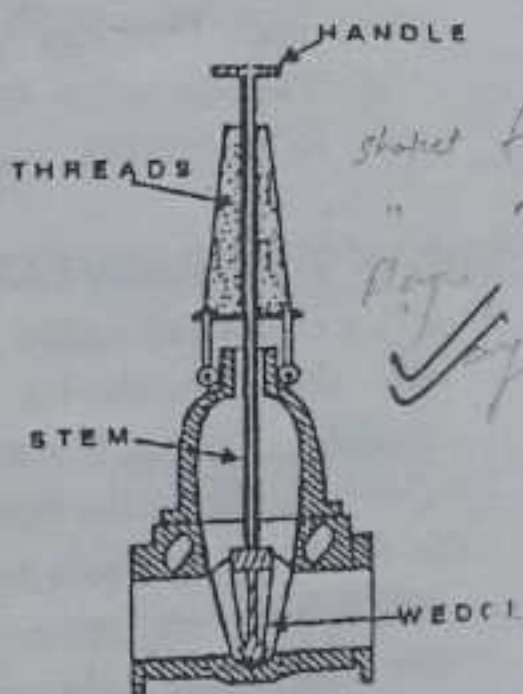

Fig. 9.1 Sluice Valve

b. Reflex or check or non-return valve:

When flow in one direction only in the pipe is required, a valve is used which is called reflux or check or non-return valve. Normally it is placed after pump component.

Reflux valve consists of a disc pivoted at the one end in such way that it opens when flow is forward and closes if water tend to flow in reverse direction. (See fig 9.2)

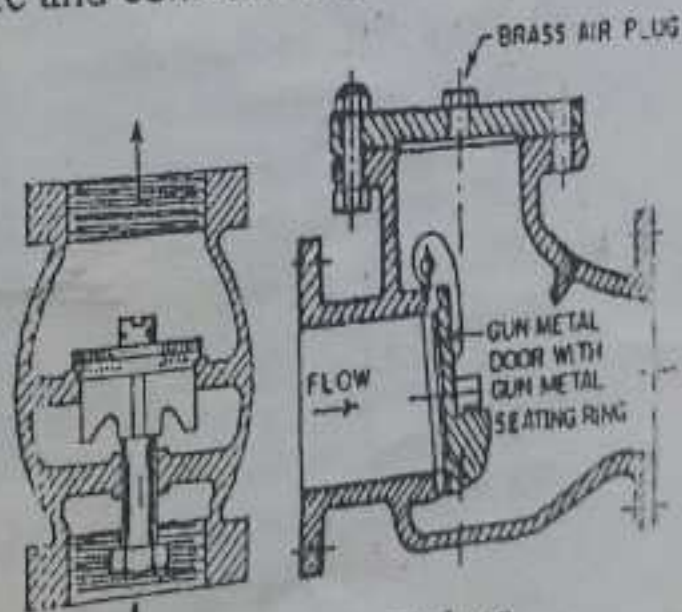

Fig. 9.2 Reflex Valves (Vertical and horizontal)

c. Safety or pressure relief valve or automatic cutoff valve:

✓ Where the pressure in the pipeline is maximum and pipes are liable to burst, a kind of valve is used to release the unwanted pressure is called safety valve or pressure relief valve.

(See fig 9.3)

✓ Pressure relief valve consists of a disc controlled by a spring which can be adjusted for any desired pressure. When pressure exceeds from that desirable limit the disc is forced from seat and pressure is relieved through cross pipe and comes down and closes automatically when pressure is lowered. So it is also called automatic cutoff valve.

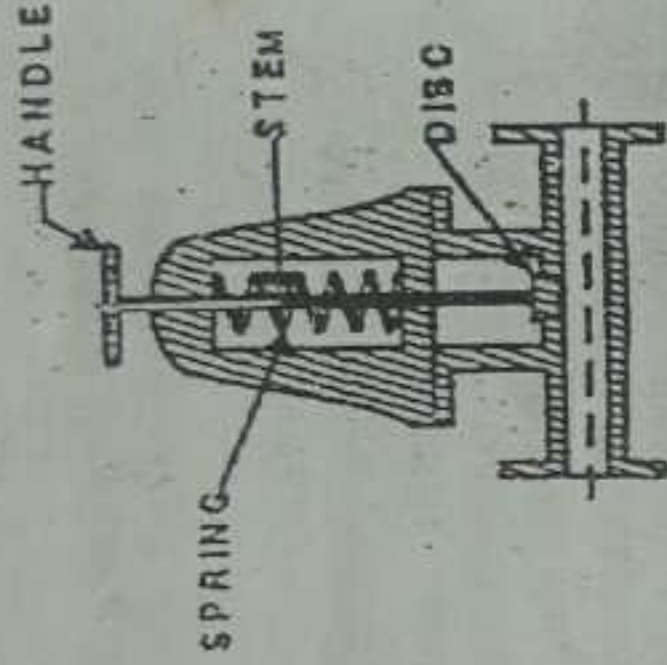

Fig. 9.3 Safety Valve

d. Air valve or air relief valve:

✓ Air enters in the water supply pipes with water and accumulated at the highest (summit) point which may block the flow of water hence at the highest (summit) point a type of valve called air valve or air relief valve is placed to release this accumulated air. (See fig 9.4)

✓ Air relief valve consists of a cast iron chamber bolted on the pipe over the opening in the crown. A float valve and a lever in it are so adjusted that when the chamber is filled with water under pressure from the pipe below, the float remains raised up and opening is closed.

✓ If there is no water but accumulated air in the chamber, the float sinks then this opening is opened and all air is released. Again if water level rises, the opening is closed automatically.

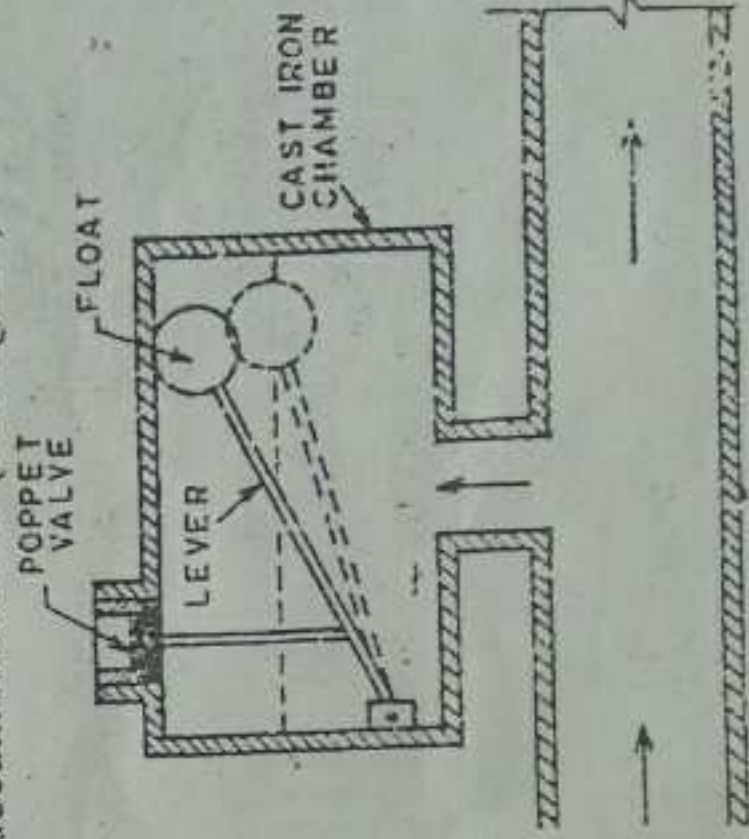

Fig. 9.4 Air Valve

e. Drain or scour or blow off valve:

- ✓ Water may carry sand and silt which may be deposited in the pipe line (normally in intermittent system)
- ✓ To emptying or draining the pipe for removing sand and or silt deposited in the pipe and for inspection, repair etc, an ordinary sluice valve is placed at the dead ends and at depressions (low point) is called the drain or blow off valve.

f. Butterfly valve and globe valve:

- ✓ Both Butterfly and globe valve are used for regulating the flow through pipes as in sluice valve but the head loss is higher than in sluice valve. (See fig 9.5)
- ✓ Butterfly valve is placed in the larger diameter pipes because of low cost.

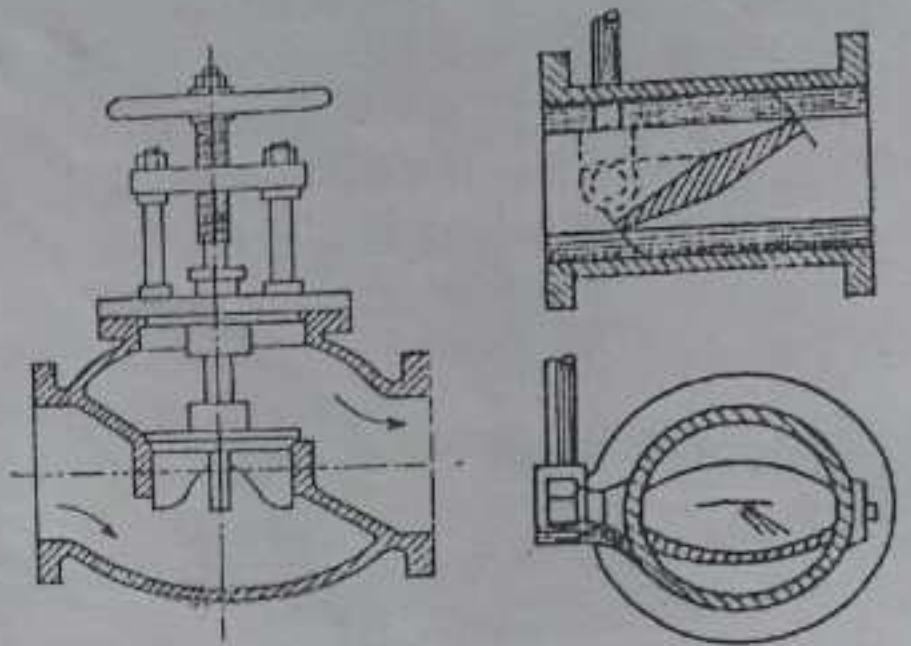

Fig. 9.5 (a) Globe Valve (b) Butterfly Valve

9.3 FITTINGS

➤ Different fittings are available for different purpose which are as follows:

a. Fittings for pipe:

- ✓ Unions, caps, plugs, flanges, nipples, crosses, tees, elbows, bend etc. (See fig 9.6)

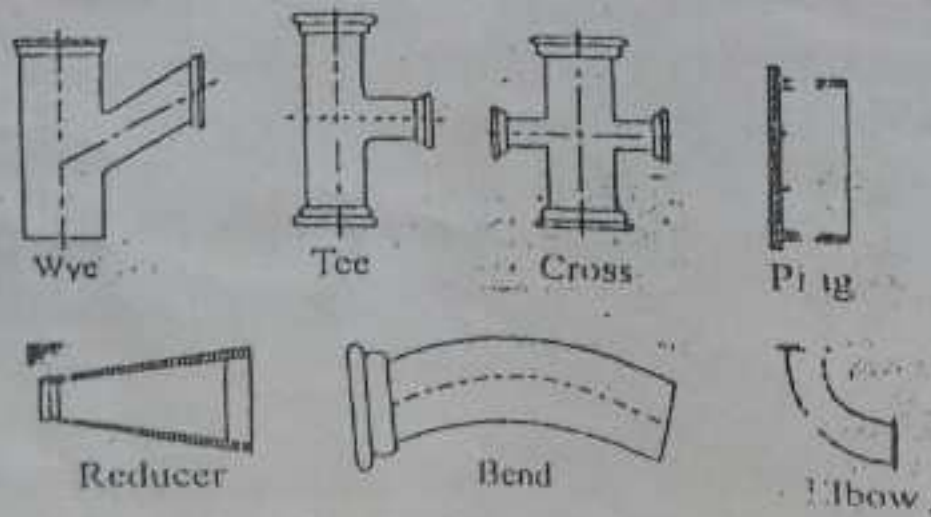

Fig. 9.6 Fittings for pipes

b. Stop cocks and water taps:

- ✓ Stop cocks and water taps are generally constructed inside the buildings and streets to use water in controlled flow. (See fig 9.7)

- ✓ Normally stop cock is provided to regulate flow before and then water tap as outlet for taking water. Both can be easily closed and opened by rotating the handle.
- ✓ Various varieties of stop cocks and water taps are available in the market.

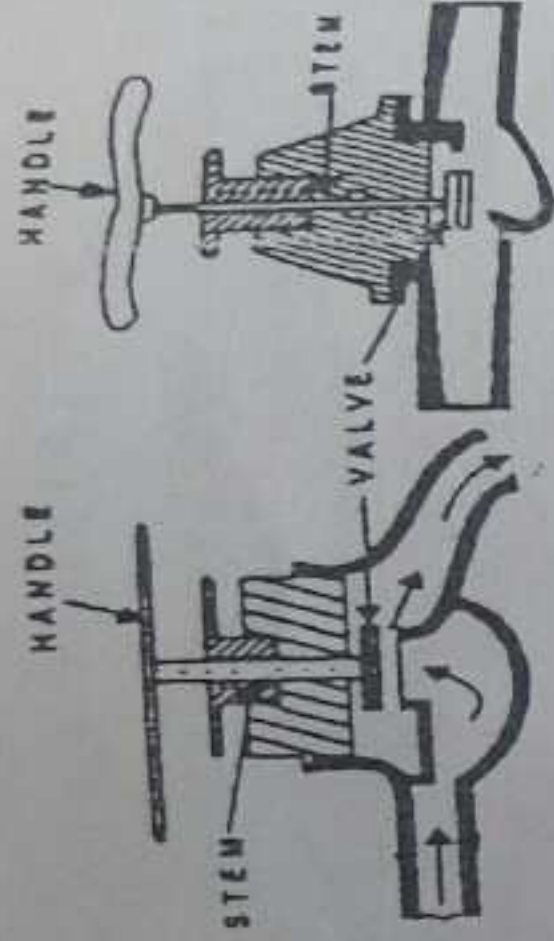

Fig. 9.7 (a) Water Tap (b) Stop cock

c. Water meters:

- ✓ It is a device used to determine the quantity of water flowing through the pipes. (See fig. 9.8)
- ✓ Various types are available in the market.

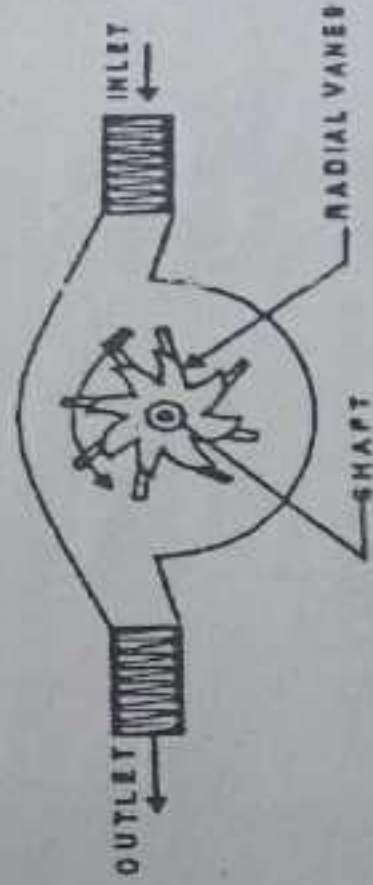
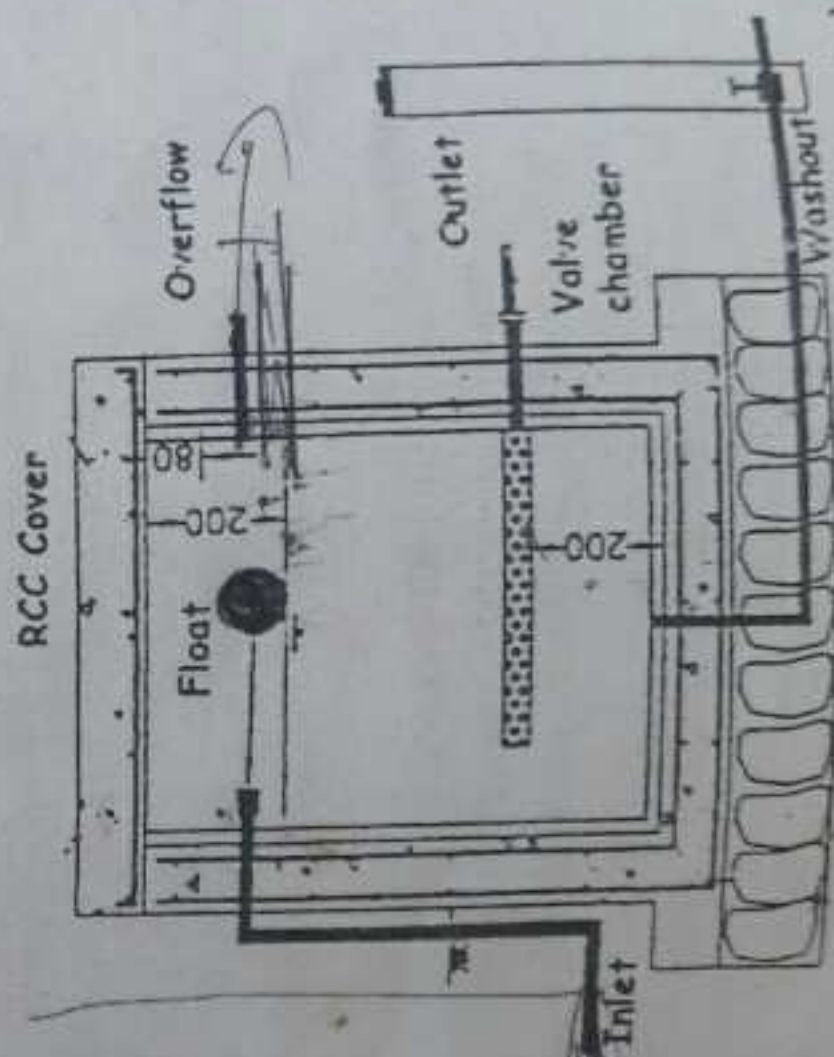

Fig 9.8 Rotary Water Meter

4 BREAK PRESSURE TANKS

- It is a tank constructed in the distribution line to break the static pressure if pipe line exceeds its maximum pressure rating to save the pipe from bursting. (See fig. 9.9 a & b)
- This tank allows the flow to discharge in the open atmosphere so reduces the hydrostatic pressure to zero and establish the new static level.
- It may be rectangular, circular or square in plan and made of masonry or RCC or Ferro cement.
- BPT has provision of a closed chamber with inlet, outlet, overflow and a float valve to stop the wastage of water and allow reserving at u/s tanks.
- A reservoir may also act as a BPT.



Vertical Section (Circular/Rectangular/square in plan)

Fig 9.9(a) Simple Break pressure Tank

9.5 PUBLIC STAND POST

- Public stand post is the last component of the w/s schemes and is the point from where people collect water at designed rate to meet their household demands normally in rural area. A type of public stand post is shown in the fig. 9.10
- Public stand post must be properly designed and aesthetically pleasant, clean and inviting place. Waste water should be properly disposed off.
- Tap stand location in Nepalese practice must be chosen by the villagers themselves and located at the place of non dispute.
- One tap stand should be constructed for every 8 - 10 households. It should be located in such a way that the fetching distance should not be greater than 200 m horizontal and should not greater than 50 m vertical.
- All tap stands must be constructed as per government agency guidelines using local materials.

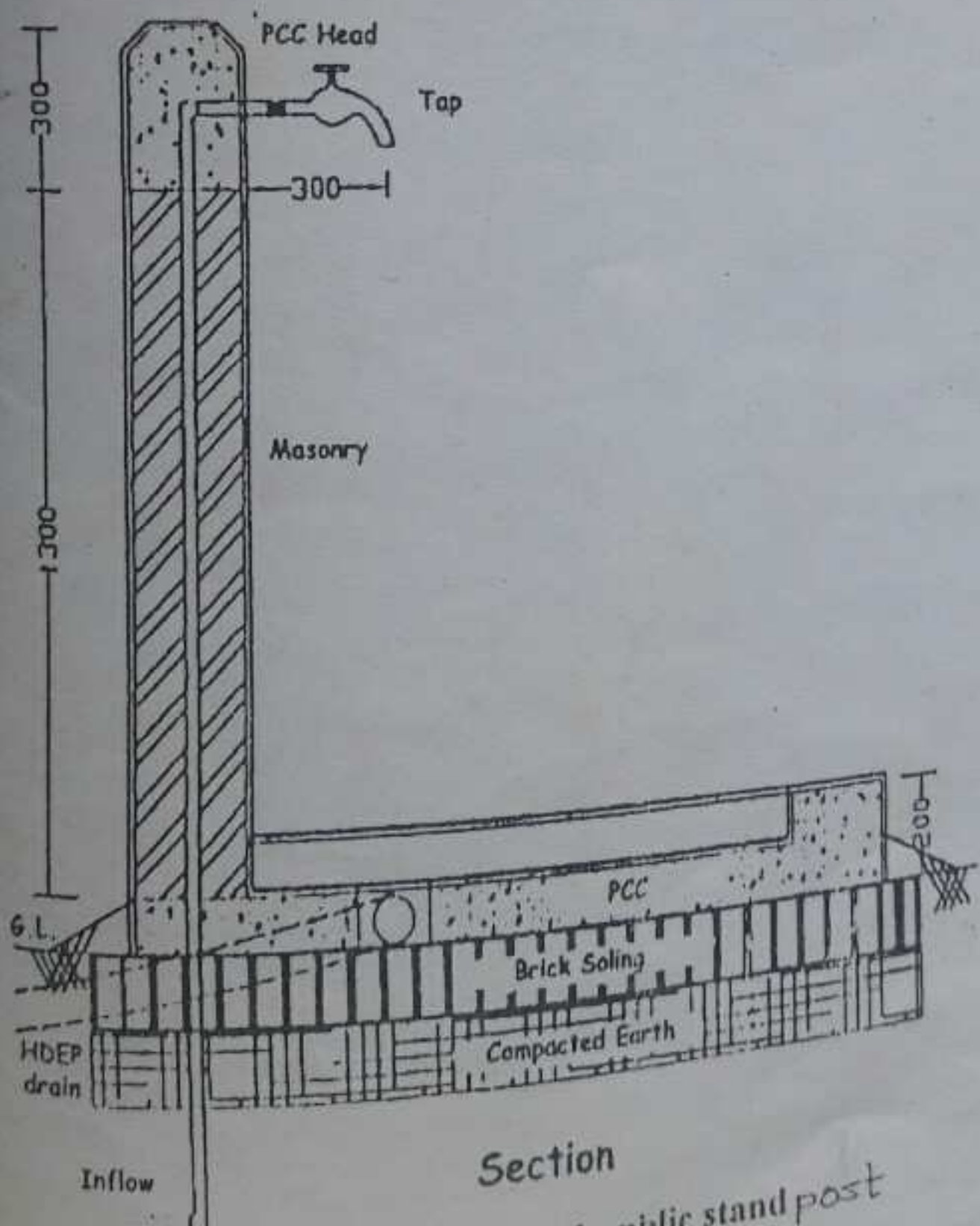

Fig 9.10 A typical public stand post

6 PROTECTION AND MAINTENANCE OF WATER SUPPLY SYSTEM

- Maintenance may be defined as the repairing of the damaged things whereas protection is the proper use and supervision of thing. Proper protection reduces maintenance.
- Proper protection as well as timely maintenance of to cracked, corroded, clogged pipes & fittings and damaged components makes water supply project sustainable.
- As per repair work, maintenance can be classified as follows:
 - a. **Preventive maintenance:**

In rainy season, source may be damaged by filling sediments; pipes may be exposed and broken. In such cases, construction of protective walls, plantation, construction of catch drains, plantation is done for protection from further damage which is called preventative maintenance.
 - b. **Emergency maintenance:**

During floods, landslide or natural disasters, the source, tanks, pipes, valves, other components of water supply etc may get damaged. In such cases immediate maintenance is needed for re-supply which is called emergency maintenance. It may be costlier.
 - c. **Regular maintenance:**

Pipe and valve leakage, clog, tap break, pipe exposure, infrastructure damage etc may occur during regular supply of water. This problem should be solved immediately by cleaning or replacing which is called regular maintenance. If damage is major it may be costlier.

Protection works:

It means the protection of new water supply project. It includes the protection of:

1. **Source:** Plantation, fencing, keeping cleanness around source, making catch drains etc.
2. **Tanks and valves:** It includes the protection of storage tank, distribution tank, sedimentation tank, valves etc by fencing, plantation, regular cleaning, proper outflow management etc.
3. **Pipeline:** Regular checks, filling of exposed pipes immediately, plantation to protect from probable landslide etc.
4. **Tap:** Includes protection of water tap, tap stand and platform from children, waste water management, fencing etc.
5. **Tools, equipments and plants:** Proper use, storage and cleaning of tools equipments used in regular supply and maintenance.

TUTORIAL I

1. The following data are the monthly inflows during the critical low water period at the site of the proposed dam and estimated monthly demand for water supply. Find the required useful storage capacity of the impounded reservoir. [Ans: 75.4 ha-m]

Month	Jan	Feb	Mar	Apr	May	Jun	Jul	Aug	Sep	Oct	Nov	Dec
Inflow (ha-m)	8.6	2.2	1.8	0.0	0.0	13.5	280.6	510.2	136.0	52.5	20.6	12.3
Demand (ha-m)	14.5	15.8	16.2	16.8	17.5	18.0	18.0	17.0	16.5	16.0	15.8	15.0

2. The following monthly inflow data in a stream are observed and monthly demand for water supply scheme are estimated below:

Month	Jan	Feb	Mar	Apr	May	Jun	Jul	Aug	Sep	Oct	Nov	Dec
Inflow (ha-m)	1.2	0.0	0.0	0.0	0.0	0.0	240.0	480.0	1.0	0.6	0.5	0.2
Demand (ha-m)	15.8	14.3	9.6	4.8	3.5	3.4	5.0	5.0	10.0	15.6	16.8	16.8

What is the required capacity of the impounded reservoir?

[Ans: 107.1 ha-m]

3. The following table gives the monthly inflows during the critical low water period at the site of the proposed dam and the estimated monthly demand for water supply. Find the capacity of the impounded reservoir to be designed. [Ans: 66.8 ha-m]

Month	Jan	Feb	Mar	Apr	May	Jun	Jul	Aug	Sep	Oct	Nov	Dec
Inflow (ha-m)	0.0	0.0	2.7	6.0	6.7	138.3	210.2	80.8	34.2	8.8	3.0	0.0
Demand (ha-m)	5.5	5.5	10.5	13.0	15.5	15.5	8.0	8.0	9.5	13.0	12.5	15.5

4. Compute the storage needed for an impounding reservoir, for a constant draft of 300 million liters per month, with the following recorded mean monthly values. [Ans: 1800×10^6 ltr]

Order of the Month	1	2	3	4	5	6	7	8	9	10	11	12	13	14
Observed Monthly Mean runoff (Million liters)	1200	1500	600	100	80	30	10	0	20	60	800	1000	1200	700

5. The following data gives the monthly inflows during the critical low water period at the site of the proposed dam. Determine analytically the storage capacity required for the impounded reservoir to maintain a constant draft of 3000 million liters of water per month. Discuss the feasibility of project. [Ans: 14320.4×10^6 liter, feasible]

Month	Jul	Aug	Sep	Oct	Nov	Dec	Jan	Feb	Mar	Apr	May	Jun
Inflow (m^3/s)	1.87	2.99	3.31	0.75	0.00	0.00	0.00	0.40	0.56	0.85	1.25	1.84

Note: Feb is of 28 days; Sep, Nov, Apr, Jun are of 30 days and all others are of 31 days

6. A runoff on a runoff river for 12 month period is observed as shown in the table below. Calculate analytically the storage capacity of a impounded reservoir to meet a constant draft of 12.5 cumecs of water per month. [Ans: To see project feasibility?]

Month	Apr	May	Jun	Jul	Aug	Sep	Oct	Nov	Dec	Jan	Feb	Mar
Inflow (m^3/s)	4.7	3.25	1.95	1.42	0.53	0.33	0.28	0.36	0.38	0.27	9.35	12.5



DETERMINATION OF ALKALINITY

(Required for solving question 8, 9 & 10 of tutorial 3)

It is determined by titration with N/50 or N/40 solution of H_2SO_4 and two indicators are used

a. *Phenolphthalein*: It gives pink at $pH > 8.2$, colorless at $pH < 8.2$. It gives Phenolphthalein alkalinity.

b. *Methyl orange*: It gives red at $pH < 4.5$, yellow-orange at 4.5. It gives Total alkalinity.

Alkalinity is also expressed in as $CaCO_3$ equivalent and given by the following:

- If N/50 solution is used, 1ml is equivalent to 1 mg of $CaCO_3$. Then,

$$\text{Alkalinity as } CaCO_3 = \frac{\text{ml of titrant used to reach end point}}{\text{ml of water sample taken}} \times 1000 \text{ (mg/l) and}$$

- If N/40 solution is used, Then, this should be multiplied by $\left[\frac{N/40}{N/50} = 1.25 \right]$. Then,

$$\text{Alkalinity as } CaCO_3 = \frac{\text{ml of titrant used to reach end point}}{\text{ml of water sample taken}} \times 1250 \text{ (mg/l)}$$

Procedure of titration:

1. Take 100 ml of sample (V_1). Add 3 to 4 drops of Phenolphthalein indicator and titrate using N/50 H_2SO_4 till the pink changes to colorless. Record the volume of acid used (V_p). It gives Phenolphthalein alkalinity (P).
2. Again in the same add methyl orange and continue titration using N/50 H_2SO_4 till the red colour changes to yellow orange. Record the total volume of acid used for both (V_m). It gives total alkalinity as $CaCO_3$ (T).

$$P = \frac{V_p}{V_1} \times 1000 \text{ mg/l} \quad \& \quad T = \frac{V_m}{V_1} \times 1000 \text{ mg/l, if N/50 } H_2SO_4 \text{ is used and}$$

$$P = \frac{V_p}{V_1} \times 1250 \text{ mg/l} \quad \& \quad T = \frac{V_m}{V_1} \times 1250 \text{ mg/l, if N/40 } H_2SO_4 \text{ is used and}$$

3. Now comparing P & T: the hydroxide, carbonate and bicarbonate alkalinity can be computed with the help of the following table

Result	Alkalinity as $CaCO_3$		
	Hydroxide (OH^-)	Carbonate (CO_3^{2-})	Bi carbonate (HCO_3^-)
$P = 0$	0	0	T
$P < 0.5 T$	0	2P	$T - 2P$
$P = 0.5 T$	0	2P	0
$P > 0.5 T$	$2P - T$	$2(T - P)$	0
$P = T$	T	0	0

Remember:

Range of pH range	No alkalinity	Bicarbonate alkalinity	Carbonate alkalinity	Total alkalinity	Caustic or hydroxide alkalinity
	0 - 4.5	4.5 - 8.2	8.2 - 10	4.5 - 14	> 8.2

- a. For simplicity, Assume HCO_3^- & OH^- can't come together.
- b. Assume alkalis other than HCO_3^- , OH^- & CO_3^{2-} are absent.
- c. OH^- alone gives initial pH about 10.
- d. CO_3^{2-} will present at $pH \geq 8.2$.
- e. HCO_3^- alone gives initial pH
- f. OH^- & CO_3^{2-} together give initial pH about 10.
- g. HCO_3^- & CO_3^{2-} can exist together.
- h. Neutralization of OH^- is complete at pH 8.2.
- i. Neutralization of CO_3^{2-} is half complete at pH 8.2 & full at pH 4.

1. Find the settling velocity of a discrete particle in water under conditions when Reynold's number is less than 0.5. The diameter and specific gravity of the particle is 5×10^{-3} cm and 2.65 respectively. Water temperature is 20°C . (Kinematic viscosity ' ν ' of water at $20^\circ\text{C} = 1.01 \times 10^{-2}$ cm²/sec).
[Ans: 2.23 m/s]
2. Find the settling velocity of spherical silica particle of specific gravity 2.67, in water at 25°C , if the diameter of the particle is; (a) 0.004 cm, (b) 0.04 cm and (c) 0.4 cm.
[Ans: (a) 1.62 mm/s (b) 74.21 mm/s (c) 467.14 mm/s]
3. Find the diameter of particles with specific gravity of $\frac{1.2}{2.65}$ removed in a tank having a surface area of 250 m^2 and treating 8 million liters of water per day. Assume temperature of 26°C . [Ans: 0.019 mm]
4. A settling tank is designed for an overflow rate of 4000 liters per m^2 per hour. What percentage of particles of diameter (a) 0.05 mm and (b) 0.02 mm, will be removed in this tank at 10°C ? Assume specific gravity as 2.65.
[Ans: (a) 100% (b) 24.86%]
5. In a continuous flow settling tank of 3 m deep and 60 m long, what flow velocity of water would you recommend for effective removal of 0.025 mm particles at 25°C . The specific gravity of particle is 2.00 and kinematic viscosity ' ν ' for water may be taken as $0.01 \text{ cm}^2/\text{sec}$.
[Ans: 11.24 mm/s]
6. Compute the dimensions of a continuous flow rectangular settling tank for a population of 20000 persons with a daily per capita water allowance of 120 liters. Assume the detention period as 6 hours.
7. Design a plain sedimentation tank to treat 5 million liters per day of water. Assume effective depth of tank as 3 meters and detention period as 6 hrs.
8. Determine the surface area of a settling tank for $0.5 \text{ m}^3/\text{sec}$ design flow, using the design overflow rate as $32.5 \text{ m}^3/\text{d}/\text{m}^2$. Find the depth of the clarifier for the overflow rate and detention time of 95 minutes. Assume length to width ratio for settling tank between 2:1 and 5:1, and length not to exceed 100 m. Recommend the dimension of tank.
9. A circular sedimentation tank fitted with standard sludge removal equipment is to handle 3.6 million liters per day of water. If the detention period of the tank is 5 hours and the depth of the tank is 3 m, what should be the diameter of the tank?
10. Find the dimension of (a) Rectangular and (b) Circular sedimentation tank from the following data; Volume of water to be treated = 3 million liters per day, detention period = 4 hrs and velocity of flow = 10 cm/min.
11. Two primary settling basins are 25 m in diameter with 2.5 m side water depth. Single effluent weirs are located on the peripheries of the tanks. For water flow of $30000 \text{ m}^3/\text{day}$, calculate (a) surface area and volume (b) overflow rate in $\text{m}^3/\text{m}^2 \cdot \text{day}$ (c) detention time in hours and (d) weir loading in $\text{m}^3/\text{m}/\text{day}$.
[Ans: (a) 490.87, 1398.4 (b) 30.558 (c) 2.2375 (d) 190.985]
12. 3.875 million liters of water per day passes through a sedimentation basin which is 6 m wide, 15 m long and 3 m deep. (a) Find the detention time for this basin. (b) What is average velocity of flow through this basin? (c) If the suspended solids content of the water averages 40 ppm, what weight of dry solids will be deposited every 24 hours, assuming 75% removed in the basin? (d) Compute the surface overflow rate?
[Ans: (a) 1.71 hrs (b) 0.144 m/min (c) 113.55 kg/day (d) $42.06 \text{ m}^3/\text{m}^2/\text{day}$]
13. A rectangular sedimentation basin is to handle 10 million liters/day of raw water. A detention basin of width to length ratio 1:3 is proposed to trap all particles larger than 0.04 mm in size. Assuming a relative density of 2.65 for the particles and 20°C as the average temperature, compute the basin dimensions. If the depth of the tank is 3.5 m, calculate the detention time.
[Ans: $15.54 \text{ m} \times 5.18 \text{ m} \times 3.5 \text{ m}$, 40.65 min]

Example 7.5
A dead end type of a distribution pipe network has been adopted for supplying water to a zone of city having different blocks and their population as shown in the figure.

Water Supply Engineering

14. Design a slow sand filter beds from the following data:
(a) Population to be served = 60,000 persons
(b) Average rate of demand = 160 lpcd
(c) Rate of filtration = 150 liters/hr/m²
(d) Length of each bed = Twice the breadth
(e) Assume maximum demand as 1.8 times the average daily demand.
(f) Assume that one unit will be kept standby.
[Ans: 6 nos of 44 m × 22 m (1 standby)]
15. Determine the dimension of slow sand filter for 1.0 MLD flow. Take filtration rate as 20 liters/hr/m².
16. Design a slow sand filter for a town of 20000 with an average rate of demand as 150 lpcd. Assume other necessary data suitably.
17. Determine the dimension of a set of rapid sand filters (gravity type) for treating water required for a population of 100000 with an average rate of demand 200 lpcd.
18. A city has population of 100,000 with an average rate of demand of 160 lpcd. Design a rapid sand filter.
19. Determine the diameter of rapid sand filter for 4.5 MID flow. Assume necessary data suitably.
20. Calculate the quantity of bleaching powder required per day for disinfecting 4 ML per day. The dose of chlorine has to be 0.5 ppm and the bleaching powder contains 30% of available chlorine.
[Ans: 6.67 kg/day]
21. Calculate the quantity of bleaching powder required per year for disinfecting 5 million liters per day. The dose of chlorine has to be 0.3 ppm and the bleaching powder contains 30% of available chlorine.
[Ans: 1.825 tonnes /yr]
22. Chlorine uses in the treatment of 200000 cubic meters of water per day is 8 kg/day. The residual chlorine after 10 minutes contact is 0.2 mg/l. Calculate the dosage of chlorine in mg/l and chlorine demand of water.
[Ans: 0.2 mg/l]
23. Design a water softening plant for the clear water works from the following data:
(a) Quantity of water to be treated = 25000 liter/hr
(b) Hardness in water as CaCO₃ = 400 ppm
(c) Hardness to be obtained in the supplies as CaCO₃ = 50 ppm
(d) Ion exchange capacity of Zeolite = 10 kg of hardness per m³ of zeolite
(e) Salt required for regeneration of exhausted zeolite = 50 kg per m³ of zeolite.
Also assume that the industry works for 2 shifts of 8 hrs each, per day. Make suitable assumptions where needed, if not given.
24. Design a water softening plant for a water works from the following data:
(a) Hardness in water = 450 mg/liter as CaCO₃
(b) Quantity of water to be treated = 25000 liter/hr
(c) Allowable hardness after treatment in the work = 50 mg/liter as CaCO₃
(d) Ion exchange capacity of resin to be used in the plant = 10 kg of hardness per m³
(e) Salt required for regeneration of resin = 45 kg per m³ of resin
The water softening plant works for 2 shifts of 8 hrs per day. Assume any suitable data where necessary.



Example 7.5

A dead end type of a distribution pipe network has been adopted for supplying water to a certain zone of city having different blocks and their population as shown in the figure below. The average rate of supply is being 200 liters per head per day. Design the sizes of the pipes with the following assumptions:

a. The populations in different blocks may be assumed as P in figure below:

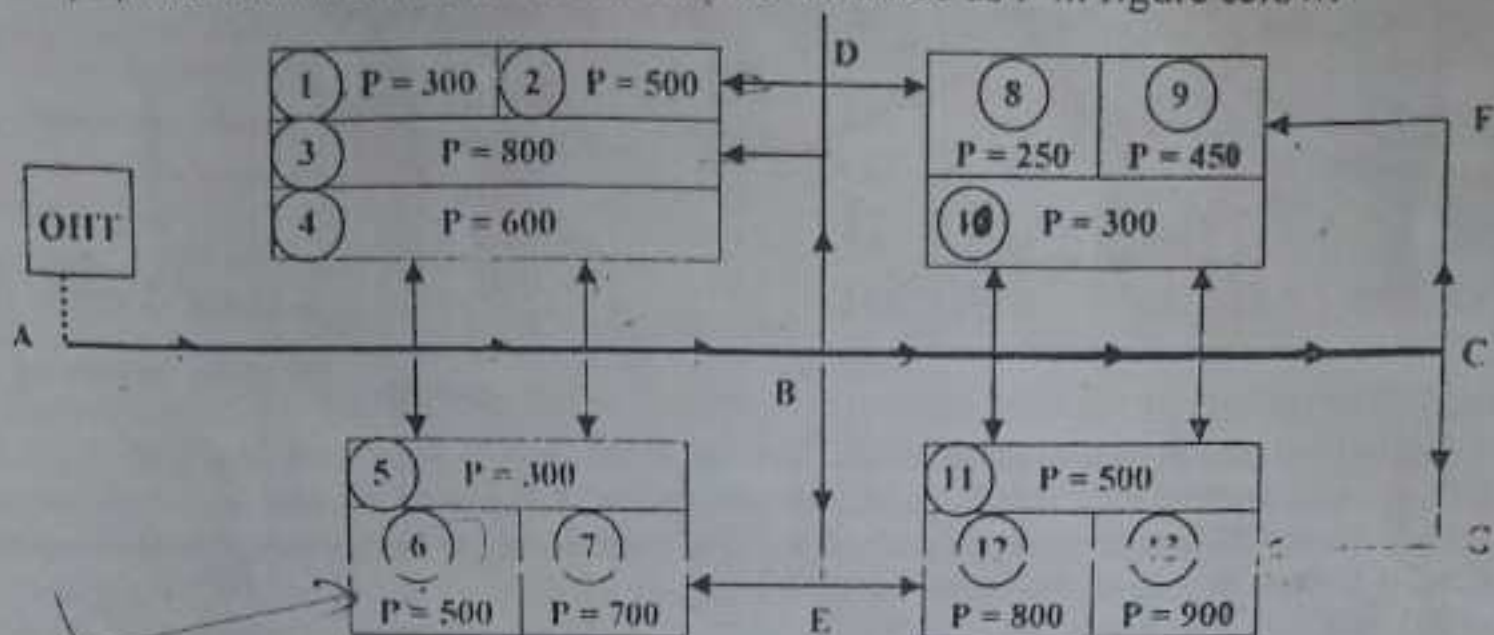

- b. The RL of the bottom of the storage tank may be taken as 225.00 m.
 c. The RL of the points along the main road are: A = 210 m, B = 200 m, C = 195 m.
 d. The length of AB, BC may be taken as 500 m and 400 m respectively.
 e. The distribution system may be designed for a maximum demand equals to 2.7 times the average demand.
 f. The minimum pressure head to be maintained at any point in the distribution system may be assumed as 12 m.

Solution:

The figure may be simplified as follows:

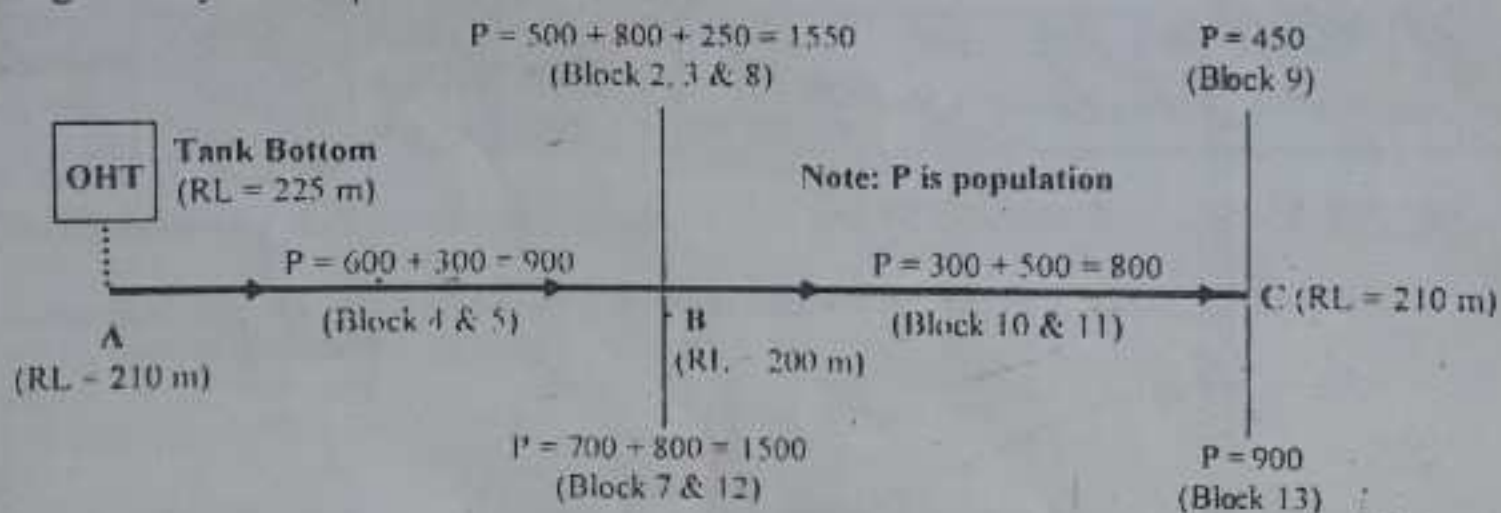

Given, rate of supply (q) = 200 lpcd, peak factor (P_f) = 2.7,

Min pressure head required (H_{min}) = 12 m, Assume $C = 100$

Distance (L): AB = 500 m, BC = 400 m

Population served by pipe BC (P_{bc}) = previous + local = 450 + 900 + 800 = 2150 nos

Population served by AB (P_{ab}) = previous + local = 2150 + 1550 + 1500 + 900 = 6100 nos

$$\text{Design discharge for AB } (Q_{ab}) = q \cdot P_f \cdot P_{ab} = \frac{200 \times 2.7 \times 6100}{24 \times 60 \times 60} = 38.1 \text{ lit/s} = 38.1 \times 10^{-3} \text{ m}^3/\text{s}$$

$$\text{Design discharge for BC } (Q_{bc}) = q \cdot P_f \cdot P_{bc} = \frac{200 \times 2.7 \times 2150}{24 \times 60 \times 60} = 13.4 \text{ lit/s} = 13.4 \times 10^{-3} \text{ m}^3/\text{s}$$

A. Using Hazan-William's Nomogram:

Pipe	Length 'L' (m)	'Q' (lps)	Assumed 'd' (mm)	Head loss for Q & d from Hazen-William's Nomogram 'h _f ' (m)		Hydraulic level HL (m) ↑	Ground level GL (m)	Net head 'HL - GL' (m)	'V' (m/s)	Remarks
				Per 1000 m	Actual 'h _f '					
First Trial										
BC	400	13.4	120	25	10	C = 202.5	C = 195.0	C = 7.5	1.24	Net head < 12 m (So change dia)
AB	500	38.1	180	25	12.5	B = 212.5 A = 225.0*	B = 200.0 A = 210.0	B = 12.5 A = 15.0	1.60	Net head > 12 m ok
Second Trial										
BC	400	13.4	140	12	4.8	C = 207.7	C = 195.0	C = 12.7	0.93	Net head > 12 m ok
AB	500	38.1	180	25	12.5	B = 212.5 A = 225.0*	B = 200.0 A = 210.0	B = 12.5 A = 15.0	1.60	

*RI of the bottom of the tank

Note:

1. Calculation should be done from backwards.
2. 'd' is assumed in such a way that approximate velocity 0.9, 1.2, 1.5, 1.8 for 10, 15, 25 & 40 cm pipes respectively.
3. Head per 1000 m is read out from Nomogram for 'Q' and assumed 'd'. Similarly V is read from nomogram.
4. Here any size is assumed but commercially available pipes are of 10, 20, 25, 30, 40, 50, 60, 75, 90, 100, 125, 150, 175, 200, 225, 250, 300, 350, 400, 450, 500, (+100), ..., 1800, 2000, (+200), ..., 30000 mm and should be considered in the design.
5. Hydraulic level is calculated from A towards C.

B. Using Hazan-William's Formula:

Velocity (V) = Q/A = Q/(πd²/4) = (4Q)/(πd²) = 1.273Q/d² m/s,
Where, Q in m³/s and d in m.

$$\text{Head loss } (h_f) = \frac{10.68 L}{d^{4.87}} \left[\frac{Q}{C} \right]^{1.852}$$

Pipe	Length 'L' (m)	'Q' (m ³ /s)	Assumed 'd' (m)	Head loss 'h _f ' (m)	Hydraulic level HL (m) ↑	Ground level GL (m)	Net head 'HL - GL' (m)	'V' = 1.273Q/d ² (m/s)	Remarks
First Trial									
BC	400	13.4 × 10 ⁻³	0.15	2.95	C = 215.75	C = 195.0	C = 20.75	0.758	Net head > 12 m ok
AB	500	38.1 × 10 ⁻³	0.20	6.30	B = 218.7 A = 225.0*	B = 200.0 A = 210.0	B = 18.7 A = 15.0	1.212	

*RI of the bottom of the tank

So, pipes of dia. 200 mm & 150 mm may be used in portion AB & CD respectively

10. Calculate the discharge and velocity in each pipe in the network given below. The two lines are required to carry combined discharge of 33.5 lps. Assume Hazen-Williams C is 70 for GI and 140 for HDPE pipe.

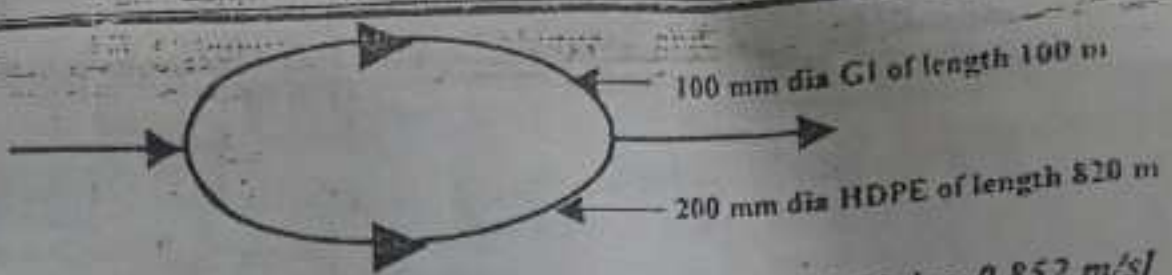

[Ans: 6.74 lps, 0.858 m/s, 26.76 lps, 0.852 m/s]

11. Calculate discharge, velocity and head loss in section BC, CD, DE and ED. Take C = 100 for all CI pipes.

[Ans: 46.72 lps, 53.28 lps, 0.371 m/s, 0.660 m/s, 0.424 m/s, 0.754 m/s, 0.628 m, 3.828 m, 1.202 m, 3.255 m]



12. Design the main lines AE and BC for the population to be served from the following network. The average demand is 175 lpcd and the length of AB, BC is 700 m & 500 m respectively. RL of the bottom of the tank is 182.5 m and RL of A, B and C along the road are 166 m, 154 m & 146 m respectively. The peak factor is 3 and the minimum pressure requirement is 1.5 kg/cm².

[Ans: 200 mm, 150 mm (C=100)]

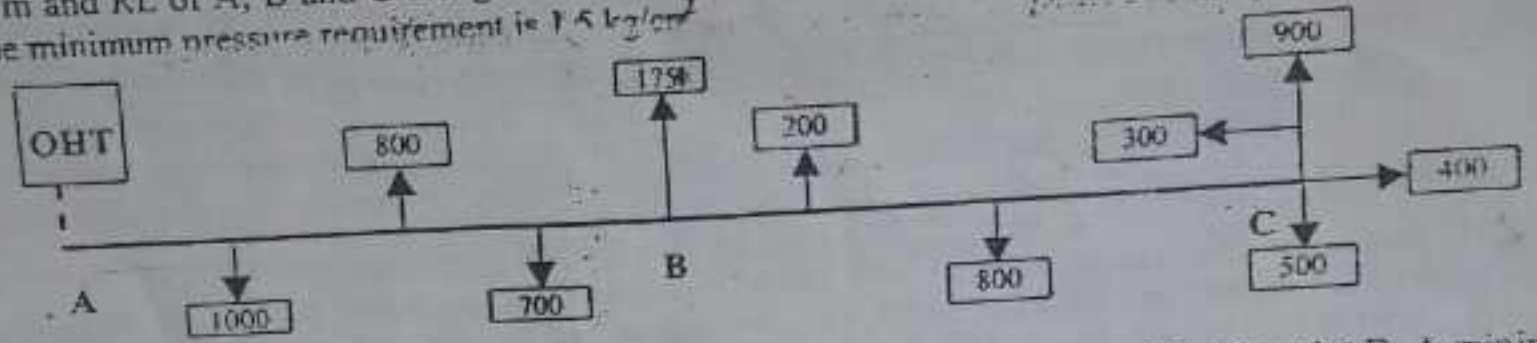

13. A scheme layout of a rural w/s system is shown in the figure. Design pipelines AB, BC and AD. A minimum pressure of 5 m of water is required at taps. Assume C = 100. [Ans: 15 mm for all]

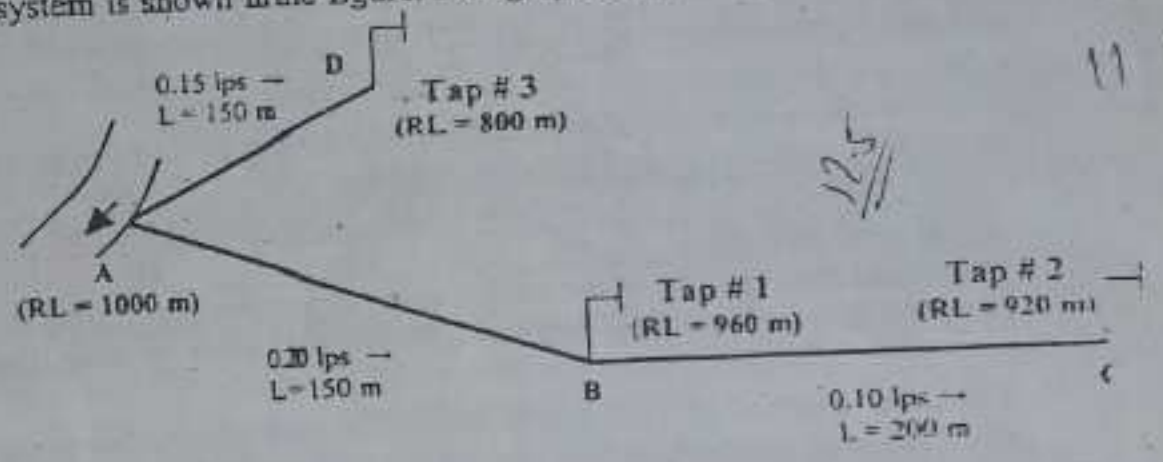

14. Design pipelines AB, BC, BD and BE. For the water distribution network shown below. Assume demand 170 lpcd, PF = 3. Min. pressure requirement = 15 m and Hazen William's coefficient = 100.

[Ans: 200 mm, 150 mm, 100 mm, 80 m]

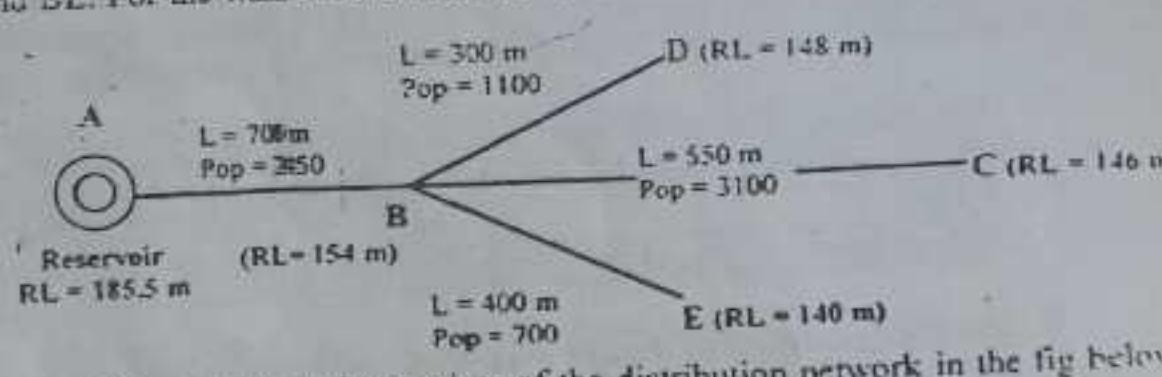

15. Calculate the head loss and corrected flows in the various points of the distribution network in the fig below after one correction. Assume C = 100.

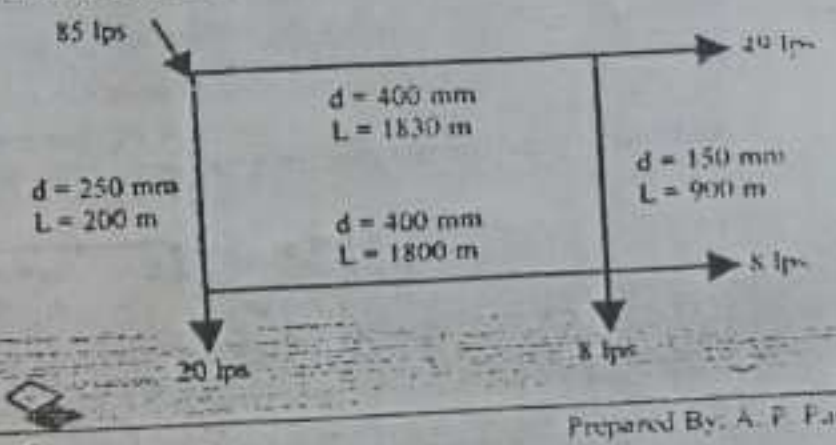

TUTORIAL 5

1. A village in Mid-western development region of Nepal has a design year water demand of 15000 liters/day. The demand is to meet by continuous system of supply from spring source with safe yield of 0.2 lps. The consumption pattern in % of a day is as follows. [Ans: 4290 liters]

Time (hours)	05 - 07	07 - 12	12 - 17	17 - 19	19 - 05
Water consumption (%)	25	35	20	20	0

Is balancing reservoir necessary? Calculate its capacity by analytical if necessary? Justify your answer.

2. For the water supply of a small rural town with the daily requirement of 2,25,000 liters, it is proposed to construct a distribution reservoir. The pattern of draw off is as under. [Ans: 155500 liters]

Time (hours)	7AM-8AM	8AM-5PM	5PM-6:30PM	6:30PM - 7PM
Water consumption (% of a daily)	25	35	20	20

The pumping is to be done at a constant rate of 8 hours per day (8 AM to 4 PM). Determine the storage capacity of reservoir from mass curve method.

- * 3. Water is to be supplied to a village having daily water demand of 66370 lit from a stream source with a safe yield of 0.78 l/sec through 22 public stand posts. Assume the flow from each public stand posts as 0.1 l/sec. Take hourly consumption pattern as follows determine the capacity of service reservoir for balancing reserve.

Distribution hours	5 AM - 7 AM	7 AM - 12 PM	12 PM - 5PM	5PM - 7 PM	7 PM - 5AM
Water consumption	25%	35%	20%	20%	0%

0.78×22 0.78

[Ans: 27058 liters]

- * 4. Determine the storage capacity of a service reservoir from analytical method for Itahari town having one million populations with per capita water demand of 150 liters/day. Assume uniform pumping is done from 6:00 to 18:00 hours. Neglect the fire demand. The variations of demand are as follows. [Ans: 52.5 ML]

Time (hours)	05 - 09	09 - 12	12 - 15	15 - 18	18 - 24
Water demand (%)	40	15	10	15	20

5. A town with a forecasted population of 0.1 million (1 lakh) is to be supplied with water daily at 200 liters per head. The variation in demand is as follows. [Ans: 8 ML]

Time (hours)	6AM-9AM	9AM-12PM	12PM-3PM	3PM-6PM	6PM-9AM	9AM-6AM
% of total demand	40	10	10	15	25	0

Determine the capacity of the service reservoir assuming pumping to be at uniform rate and the period of pumping is 6 AM to 6 PM. neglecting fire demand solve by analytical as well as mass curve method.

6. The water demand of a town is $960 \text{ m}^3/\text{d}$. The water demand is to meet through pumping from a tube well. The recommended pumping period is 4:00 to 10:00 hours in the morning and 16:00 to 22:00 hours in the evening. The water is supplied to the consumers from the reservoir by intermittent system supplying water from 5:00 to 7:00 hours in the morning and 16:00 to 18:00 hours in the evening. Calculate the capacity of the balancing reservoir by analytical method. Assume necessary data suitably. [Ans: 400 m^3]

7. Calculate the storage capacity required to supply the demand shown in the following table if the inflow of water to the reservoir is maintained at a uniform rate throughout 24 hours. [Ans: 0.68 ML]

Time	00 - 04	04 - 08	08 - 12	12 - 16	16 - 20	20 - 24
Demand in million liters	0.48	0.87	1.33	1.00	0.82	0.54

8. The water demand of a town is $3000 \text{ m}^3/\text{d}$. the water demand is to be made from the river through flowing under gravity to the reservoirs. The water is supplied to the consumers by intermittent system supplying water from 5 - 7 hours in the morning and 16 - 18 hrs in the evening. Calculate the capacity of reservoir by analytical method. Assume that consumption in the morning and evening shifts are equal. [Ans: 135 m^3]

9. Find the length of an equivalent pipe of diameter 400 mm for the network shown below. If the length of the equivalent pipe is restricted to 1500 m find it's diameter. Use Hazen-William's formula. [Ans: 3072.2m, 345.2 mm]

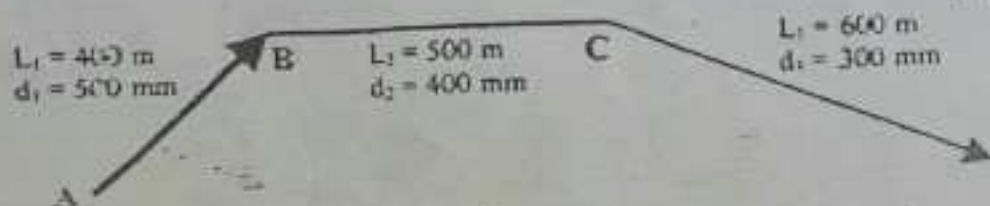

PROBABLE QUESTIONS (From detailed Lesson Plan)

Chapter 1: Introduction

- What is the necessity of water supply schemes in the present day community?
 Draw flow diagrams of urban and rural water supply schemes. Describe briefly the activities involved in planning and design of a water supply project.
 Define (a) Potable water (b) Contaminated water (c) Wholesome water.

Chapter 2: Sources of Water

- What are the various sources of water used in the water supply schemes? Discuss their merits and demerits from quality and quantity point of views.
 Describe the possible water sources for public water supply system in (a) hilly areas (b) Terai areas of Nepal.
 Under what circumstances springs are formed? With the neat sketches, describe the various types of springs.
 Differentiate between shallow and deep wells. Which of them would you prefer for use in public supply scheme and why?
 With the help of neat sketches, describe the various types of wells.
 Write short notes on: (a) Infiltration wells (b) Artesian well (c) Tube well (d) Infiltration galleries in planning and designing of a water supply project.

Chapter 3: Quantity of Water

10. Define per capita demand of water. What are the various factors affecting per capita demand of water? Discuss the various reasons of hourly fluctuations in water demand.
 11. Describe the various types of water demands that should be considered in the urban water supply scheme.
 12. Explain in brief different methods used for prediction of future population of a city with reference to the design of a water supply system.

Chapter 4: Quality of Water

13. Describe the different types of living organisms found in water. Explain their effects on purity of water.
 14. Write common impurities mostly found in natural water and briefly explain their effects on water quality.
 15. Describe the various water borne diseases that are transmitted through polluted water. Explain their effects on water quality.
 16. Describe in brief various tests conducted for physical examination of water.
 17. What do you understand by indicator organism? Describe the multiple tube fermentation technique for the determination of coliforms.
 18. Describe in detail in the membrane filter technique for the determination of coliforms.

Chapter 5: ~~Quality of Water~~ Intake Works

19. What are intakes? What are the important considerations, which govern the site selection of an intake?
 20. What are the various types of intake works? Describe a river intake with a help of neat sketches.
 21. With the neat sketches, describe the construction of a spring intake generally used in the hilly areas of Nepal.
 22. When reservoir intake is constructed? Describe a typical reservoir intake for urban areas.

Chapter 6: Water Treatment

23. What do you understand by water treatment? Why is it necessary? Give an outline of various processes adopted for treatment of water.
24. Working from fundamentals, derive Stoke's law for settlement of discrete particles in water. How do you modify the law taking into account the temperature effect?
25. Prove theoretically that the surface loading and not depth is a measure of effective removal of particles in an ideal sedimentation tank.
26. What do you understand by coagulation and flocculation? Why are they necessary? Describe various types of coagulants commonly used in water treatment.
27. Describe the various devices that are used to mix coagulants in water.
28. Explain the theory of filtration as used in purification of water.
29. Describe the operation of slow sand filter with the help of the diagram give typical values for effective size, uniform coefficient and thickness of sand bed.
30. Describe with the help of neat sketches, the component parts of the rapid sand filter. Explain its working including the method of washing.
31. Discuss the factors affecting disinfection.
32. Differentiate between permanent and temporary hardness. Explain the lime soda method of removing hardness of the water. What are its advantages and disadvantages?
33. What do you understand by aeration of water? Why is it required? Discuss the various methods commonly used for aeration of water.
34. Explain the methods of iron and manganese removal from water. Why is their removal necessary?

Chapter 7: Reservoirs and Distribution System

35. Compare the continuous and intermittent systems of water supply.
36. Why a balancing reservoir is provided in water supply scheme? How will you determine its capacity by mass curve method for 24-hour continuous pumping?
37. Discuss with the help of neat diagrams, various layouts of distribution system.

Chapter 8: Conveyance of Water

38. Describe the various types of pipe materials used for conveying water in water supply scheme. Discuss merits and demerits of any two of them.
39. Describe in detail the process of pipe laying in water supply schemes.
40. Describe with the help of neat sketches various types of joints used in CI pipes.

Chapter 9: Valves and Fittings

41. Why is it necessary to remove the accumulated air from the water pipes? How is it removed? Describe any suitable device to remove air from water pipes.
42. Why a break pressure tank is necessary in a water supply scheme? With a neat sketch, describe its construction.
43. Write short notes on:

(a) Sluice valve	(b) Reflux valve	(c) Safety valve	(d) Public standpost
------------------	------------------	------------------	----------------------

