

NEW AGE

DESIGN OF R.C.C. STRUCTURAL ELEMENTS

(R.C.C. Volume-I)

S.S. BHAVIKATTI



NEW AGE INTERNATIONAL PUBLISHERS

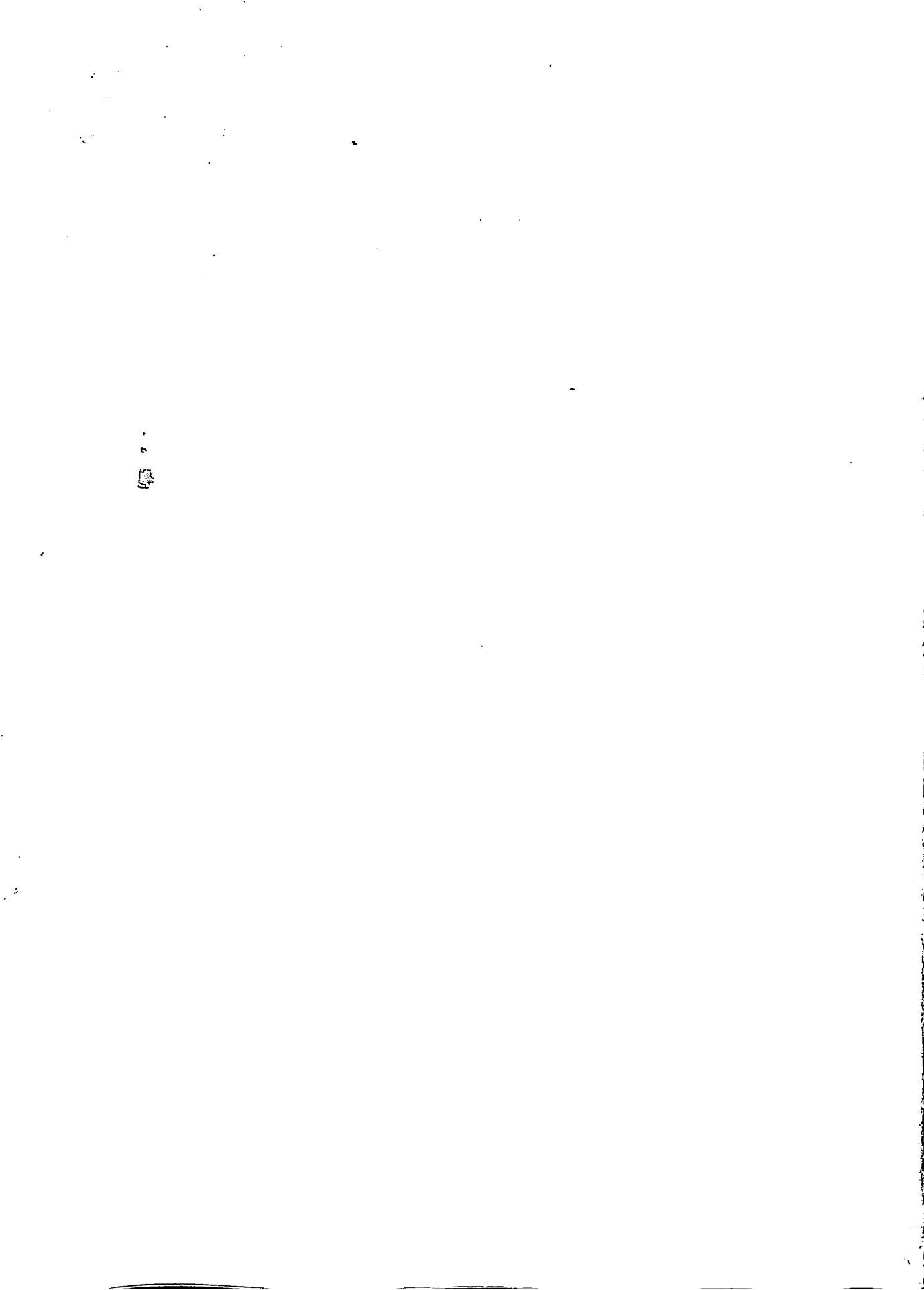

23836

23836



DESIGN OF R.C.C. STRUCTURAL ELEMENTS

(R.C.C. Volume-I)

Bharati Vidyapeeth Deemed University
COLLEGE OF ENGINEERING
Library, Pune - 411 043.

To be returned on or before the last date stamped below.
(Late fee fine Rs. 1 per day)

--	--	--



DESIGN OF R.C.C.
STRUCTURAL ELEMENTS

(Part I - Volume I)

23836



DESIGN OF R.C.C. STRUCTURAL ELEMENTS

(R.C.C. Volume-I)

S.S. Bhavikatti

Professor of Civil Engineering and
Vice Principal
Sri. Dharmasthala Manjunatheswar College of
Engineering and Technology, Dharwad
formerly
Professor and Dean
N.I.T.K., Surathkal



NEW AGE INTERNATIONAL (P) LIMITED, PUBLISHERS

New Delhi • Bangalore • Chennai • Cochin • Guwahati • Hyderabad
Jalandhar • Kolkata • Lucknow • Mumbai • Ranchi

PUBLISHING FOR ONE WORLD

Visit us at www.newagepublishers.com

Copyright © 2005, New Age International (P) Ltd., Publishers
Published by New Age International (P) Ltd., Publishers
First Edition: 2005
Reprint: 2009

All rights reserved.

No part of this book may be reproduced in any form, by photostat, microfilm, xerography, or any other means, or incorporated into any information retrieval system, electronic or mechanical, without the written permission of the copyright owner.

Branches:

- 36, Malikarjuna Temple Street, Opp. ICWA, Basavanagudi, Bangalore. ☎ (080) 26677815
 - 26, Damodaran Street, T. Nagar, Chennai. ☎ (044) 24353401
 - Hensen Complex, Mohd. Shah Road, Paltan Bazar, Near Starline Hotel, Guwahati. ☎ (0361) 2543669
 - No. 105, 1st Floor, Madhiray Kaveri Tower, 3-2-19, Azam Jahi Road, Nimboliadda, Hyderabad. ☎ (040) 24652456
 - RDB Chambers (Formerly Lotus Cinema) 106A, 1st Floor, S.N. Banerjee Road, Kolkata. ☎ (033) 22275247
 - 18, Madan Mohan Malviya Marg, Lucknow. ☎ (0522) 2209578
 - 142C, Victor House, Ground Floor, N.M. Joshi Marg, Lower Parel, Mumbai. ☎ (022) 24927869
 - 22, Golden House, Daryaganj, New Delhi. ☎ (011) 23262370, 23262368
-

ISBN (10) : 81-224-1693-4

ISBN (13) : 978-81-224-1693-0

Rs. 145.00

C-08-12-3252

Printed in India at Mehra Offset, Delhi.
Typeset at Shubham Composer, Delhi.

PUBLISHING FOR ONE WORLD

NEW AGE INTERNATIONAL (P) LIMITED, PUBLISHERS

4835/24, Ansari Road, Daryaganj, New Delhi-110002

Visit us at www.newagepublishers.com

Preface

23836

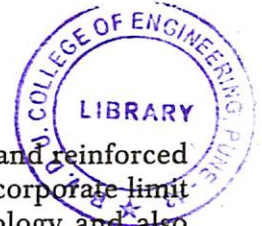

Bureau of Indian Standard is publishing code of practice for designing the plain and reinforced concrete as IS-456. The third revision of this code was brought out in 1978 to incorporate limit state method approach. To incorporate rapid developments in concrete technology and also the experiences gained, IS-456 was revised in the year 2000. The major changes are to incorporate durability requirement of concrete. Minimum grade of mix has been specified as M20 as against earlier specification of M15. The formula for estimating modulus of elasticity of concrete has been changed. Apart from these, there are many minor changes.

The author felt there is need to write a book to facilitate students and faculty of civil engineering in learning/teaching the fundamental course in civil engineering and the design of reinforced concrete strictly according to the revised code IS-456 : 2000. The scope of this book is limited to the design of R.C.C. Structural elements, which is a basic course for undergraduate students. The author intends to write advance R.C.C. book to include advance topics in R.C.C. design and also design of many R.C.C. structures.

The attempt has been made to make the book students friendly by solving many problems step-by-step in details and by giving details of reinforcement. The author invites suggestions from the users to further-improve the book and acknowledges the neat work done by the publisher.

Author

Contents

Preface	(v)
1. Introduction	1
1.1 General	1
1.2 Important Properties of Concrete	1
1.3 Important Properties of Steel	3
1.4 Code Requirement of Reinforcements	5
1.5 Loads	5
1.6 Load Combinations	11
1.7 Structural Analysis	11
1.8 Methods of R.C.C. Design	12
2. Principles of Limit State Design	14
2.1 Philosophy of Limit State Design	14
2.2 Limit States	15
2.3 Characteristic Load	16
2.4 Characteristic Strength	17
2.5 Partial Safety Factors	17
2.6 Idealised Stress Strain Curves	20
2.7 Summary of Design by Limit State Method	22
3. Flexural Strength of R.C. Sections	23
3.1 Introduction	23
3.2 Assumptions	23
3.3 Balanced, Under Reinforced and Over Reinforced Sections	24
3.4 Stress Block Parameters	26
3.5 Depth of Neutral Axis	27
3.6 Strength of Rectangular Sections in Flexure	29
3.7 Flanged Section in Flexure	36
3.8 Strength of Flanged Sections in Flexure	37
3.9 Strength of Doubly Reinforced Sections in Flexure	45
4. Strength of R.C. Section in Shear, Torsion and Bond	55
4.1 Introduction	55
4.2 Strength of Concrete Sections in Shear	55
4.3 Shear Strength of Reinforced Concrete Sections	58
4.4 Torsional Strength of R.C. Section	63
4.5 Bond Strength in R.C. Members	65
5. Limit States of Serviceability	73
5.1 Introduction	73
5.2 Deflection Limits as per IS 456-2000	73
5.3 Theoretical Method of Calculating Deflections	73
5.4 Alternate Method of Ensuring Limit State Requirements of Deflection	87

5.5 Cracking in Structural Members	91	
5.6 Crack Width Calculation	93	
6. Design of Beams		98
6.1 Introduction	98	
6.2 Types of Beams	98	
6.3 Effective Span	99	
6.4 Size of Beam	100	
6.5 Covers to Reinforcement	101	
6.6 Requirement of Reinforcements	102	
6.7 General Design Procedure	103	
6.8 Design of Singly Reinforced Rectangular Sections	103	
6.9 Design of Doubly Reinforced Rectangular Sections	107	
6.10 Design of Flanged Beams	111	
6.11 Design of Cantilever Beams	119	
6.12 Design of Continuous Beams	123	
6.13 Design of Beams Subjected to Torsion	126	
6.14 Curtailment of Tension Reinforcement in Flexural Members	131	
7. Design of Slabs		133
7.1 Introduction	133	
7.2 Design of One Way Simply Supported Slabs	134	
7.3 Design of Continuous Slab	138	
7.4 Design of Cantilever Slab	141	
7.5 Design of Two Way Slabs	144	
8. Design of Columns		156
8.1 Introduction	156	
8.2 Length of Columns	156	
8.3. Effective Length	158	
8.4. Loads on Columns	159	
8.5. Slenderness Limits for Columns	159	
8.6 Minimum Eccentricity	160	
8.7 Assumptions	160	
8.8 Design of Axially Loaded Short Column	160	
8.9 Design of Column Subjected to Combined Axial Load and Uniaxial Moment (Using SP-16)	168	
8.10 Design of Columns Subjected to Combined Axial Load and Biaxial Moments	171	
8.11 Design of Slender Columns	174	
9. Design of Isolated Column Footings		180
9.1 Introduction	180	
9.2 Types of R.C.C. Footings	180	
9.3 Load for Foundation	182	
9.4 Depth of Footing	183	
9.5 Cover	183	
9.6 Minimum Thickness	183	

9.7	Minimum Reinforcement	183	
9.8	Design of Isolated Column Footings Subjected to Axial Loads	183	
9.9	Design of Footing for Columns Carrying Axial Load and Moment	212	
9.10.	Design of Pedestal	217	
10.	Design of Stairs		221
10.1	Introduction	221	
10.2	Design of Stairs	221	
10.3	Design of Tread-Riser Type Stairs	238	
	Appendices	243	

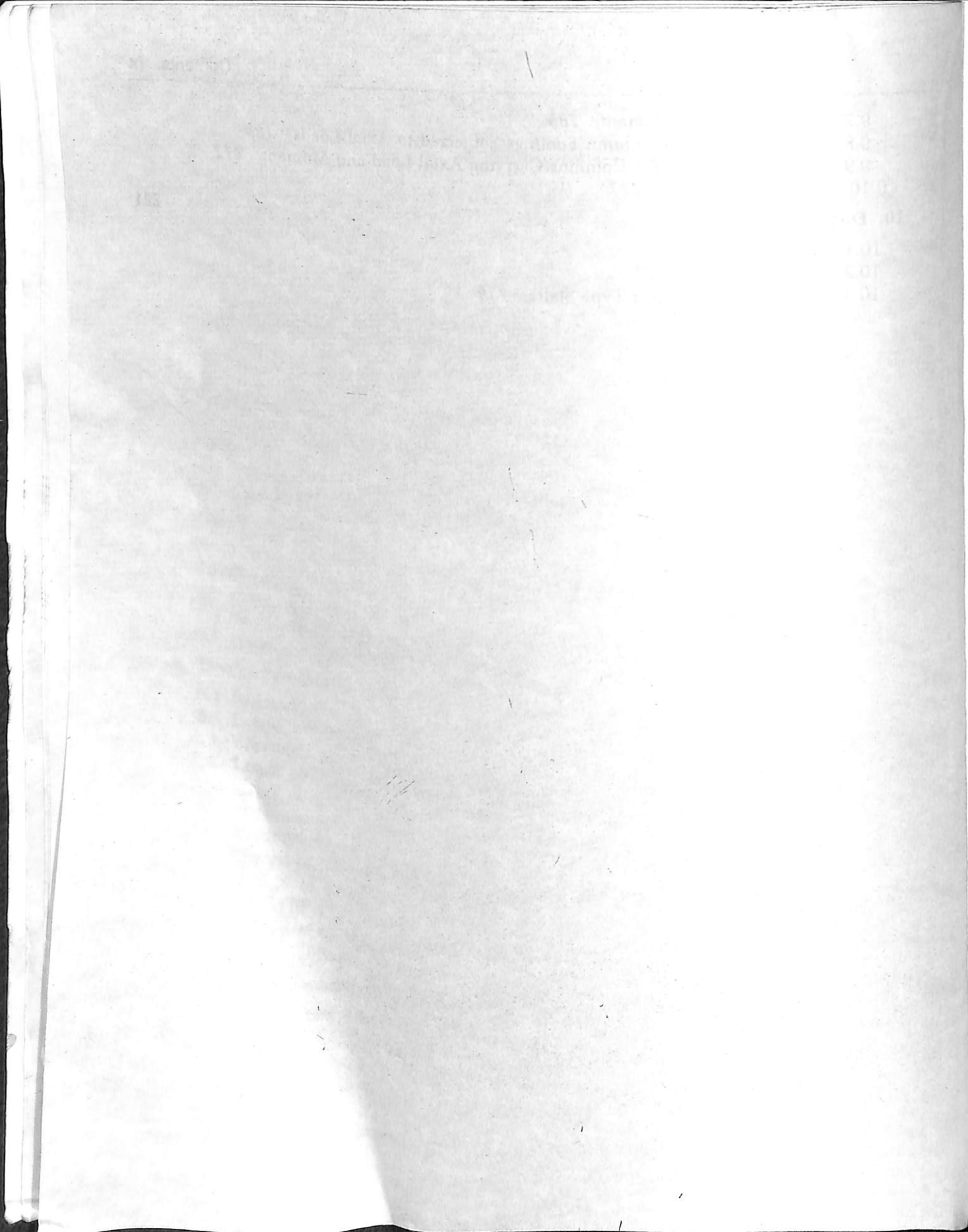

Introduction

1.1 GENERAL

Residential, educational, office and commercial buildings are the common examples of civil engineering structures. These structure consists of various elements like slabs, beams, columns, footings and staircases. Apart from the above buildings the civil engineers are associated with the design and constructions of retaining walls, water tanks, bridges, dams, towers, cooling towers.

For the construction of all the above structures very commonly used material is reinforced cement concrete (R.C.C.), which is a composite material consisting of concrete and steel.

When water is added to an intimate mixture of cement, sand (Fine Aggregate) and jelly (Coarse Aggregate), it forms a plastic mass, popularly known as concrete. This mass can be easily moulded to desired shape and size using formworks. The concrete gradually hardens and achieves the shape and size permanently. Apart from the main ingredients cement, sand, jelly and water, small quantities of admixtures like air entraining agents, water proofing agents, workability agents may also be added to impart special properties to the concrete.

Concrete is good in resisting compressive stress but is very weak in resisting tensile stress. Hence it is to be reinforced with suitable material wherever tension develops. The best reinforcement is the steel, because the tensile strength of steel is quite high and the bond between steel and concrete is very good. Reinforcements are usually in the form of mild steel or high strength deformed steel bars of diameters 6 to 32 mm. A cage of reinforcement is prepared as per the design requirement, kept in the formwork and concrete in the plastic form is poured. After concrete hardens the form work is removed. The composite material of steel and concrete (R.C.C.) is now capable of resisting compressive as well as tensile stresses.

The science of proportioning the structural elements to resist the applied loads and determining the numbers and sizes of reinforcing bars is called design of R.C.C. structures.

In this chapter important properties of concrete and steel are presented and a brief introduction is given to the various loads to be considered for the analysis. Various methods of analysis and design are very briefly discussed.

1.2 IMPORTANT PROPERTIES OF CONCRETE

The following important properties of concrete are to be noted by designer:

2 Design of R.C.C. Structural Elements

- (i) Though it consists of different materials like cement, sand and jelly the intimate mixture is so good that for all practical purposes it may be assumed as homogeneous.
- (ii) For concrete, characteristic strength is defined as compressive strength of 150mm cube at 28 days in N/mm^2 , below which not more than 5 percent cubes give the result. Based on the characteristic strength (f_{ck}), concrete is graded as given below:

Table 1.1 Grades of Concrete

Group	Grade Designation	Characteristic strength N/mm^2
Ordinary Concrete	M10	10
	M15	15
	M20	20
Standard Concrete	M25	25
	M30	30
	M35	35
	M40	40
	M45	45
	M50	50
High Strength Concrete	M55	55
	M60	60
	M65	65
	M70	70
	M75	75
	M80	80

Note: Now a days ultra high strength of grade M500 are also produced in the laboratories and M250 concrete has been used for the construction of some bridges.

IS 456 - 2000 recommends minimum grade of concrete to be used for various weather conditions as shown in table 1.2.

Table 1.2 Minimum Grade of Concrete for Different Exposure with Normal Weight Aggregates of 20mm Nominal Maximum Size. (Table 5 IS 456-2000)

Table 1.2

Exposure	Minimum Grade of Concrete
Mild	M20
Moderate	M25
Severe	M30
Very Severe	M35
Extreme	M40

The meaning of the different exposure conditions are as given in Appendix A.

- (iii) **Stress Strain Relationship:** Stress strain curve depend on strength of concrete as well as on the rate of loading. The short term stress strain curve is to be obtained for a constant rate of straining of 0.01 percent per minute or for a constant rate of stress increase of 14 N/mm^2 per minute. Figure 1.1 shows a typical stress-strain curve for different mixes for constant stress and constant strain conditions.

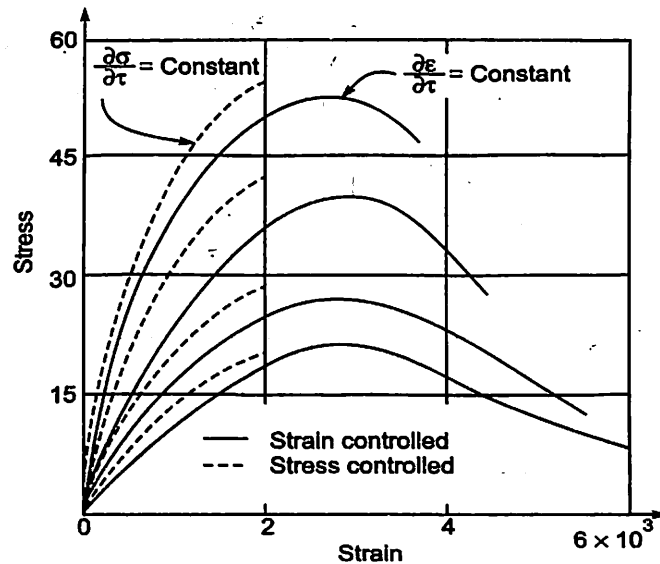

Fig 1.1. Stress Strain curve for Different Mixes of Concrete.

- (iv) **Tensile Strength** : A designer may use the following expression for flexural tensile strength of concrete:

$$F_{cr} = 0.7 \sqrt{f_{ck}} \text{ N/mm}^2.$$

Where f_{ck} is the characteristic compressive strength of concrete.

- (v) **Modulus of Elasticity**: The short term static modulus of elasticity for concrete may be taken as

$$E_c = 5000 \sqrt{f_{ck}} \text{ as per IS 456 - 2000.}$$

- (vi) **Poisson's Ratio** : It may be taken as 0.1 for high strength concrete and 0.2 for weak concrete. Usually it is taken as 0.15 for strength and 0.2 for serviceability calculations.
- (vii) **Shrinkage** : Total amount of shrinkage in concrete depends on the various factors including the amount of water present at the time of casting. In the absence of data the approximate value of the total shrinkage strain may be taken as 0.0003.
- (viii) **Creep**: It depends on various factors including the age of loading, duration of loading and stress level. The creep coefficient which is defined as ratio of ultimate creep strain to elastic strain at the age of loading may be taken as shown in table 1.3. (Clause 6.5.5.1 in IS 456 - 2000)

Table 1.3 Creep Coefficient

Age at loading	Creep Coefficient
7 days	2.2
28 days	1.6
1 Year	1.1

The ultimate creep strain shown above does not including elastic strain.

1.3 IMPORTANT PROPERTIES OF STEEL

The following important properties of steel are to be noted by a designer

4 Design of R.C.C. Structural Elements

- (i) It is treated as homogeneous material and it is really so to a very large extent.
- (ii) The characteristic strength of steel (f_y) is its tensile strength determined on standard specimen below which not more than 5 percent specimen give the results. However code permits use of minimum yield stress or 0.2 percent proof stress as characteristic strength of steel. Types of steel reinforcements available in the market are shown in table 1.4.

Table 1.4 Grades of Steel

Type	Conforming to I.S. Code	Yield Stress / 0.2% Proof Stress
Mild Steel (Plain Bars)	IS: 432 – 1966	26 kg / mm ² = 255 N/mm ²
High Yield Strength Deformed Bars (HYSD)	IS: 1786 – 1979	(i) 415 N/mm ² (ii) 500 N/mm ²
Hard Drawn Steel Wire Fabric	IS: 1566 – 1967	49 kg / mm ² = 480 N/mm ²

Taking the above values into consideration, Bureau of Indian Standards has brought up design aid to IS 456 (SP-16) for three grades of steel having characteristic strength f_y equal to 250 N/mm², 415 N/mm² and 500 N/mm². Hence the designer usually grades the available steels as Fe-250, Fe-415 and Fe-500.

- (iii) *Stress Strain Curve.* The typical stress strain curve for the above grades of steel is shown in Fig 1.2. It may

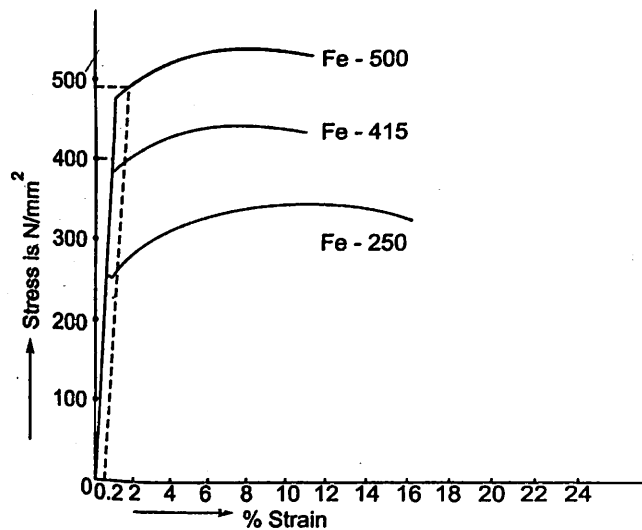

Fig 1.2. Stress strain curve for Fe – 250, Fe -415 and Fe – 500 steel

be noted that for mild steel (Fe-250) the yield point is clearly visible whereas there is no yield point for Fe-415 and Fe-500 steel. For these two steels, 0.2 percent proof stress is taken as characteristic strength f_y .

- (iv) The characteristic strength f_y in tension and in compression is taken as the same.

(v) the young's modulus (E) for all grades of steel is taken as $200\text{kN/mm}^2 = 2 \times 10^5 \text{ N/mm}^2$.

The reinforcing bars are generally available in the market in the following sizes:

Diameter of bars in mm.

Mild steel 6, 10, 12, 16, 20, 25, and 32.

Deformed steel bars 8, 10, 12, 16, 20, 22, 25, 28 and 32

1.4 CODE REQUIREMENT OF REINFORCEMENTS

- (i) Mild steel conforming to IS 432, high strength deformed bars conforming to IS 1786 and hard-drawn steel fabrics conforming to IS 1566 may be used as reinforcements. Structural steel conforming to grade A of IS 2002 are also permitted.
- (ii) All bars should be free from loose mill scales, loose rust, mud, coats of paint or any other material which destroy or reduce the bond.
- (iii) If required, in exceptional cases and for rehabilitation of structures, special chemical coatings may be provided to reinforcements.
- (iv) For main bars steel of same grade should be used as main reinforcement. Simultaneous use of two different grades of steel for main and secondary reinforcement is permitted.
- (v) Bars may be arranged singly or in pairs. Use of 3 or 4 bundled bars is also permitted. Bundled bars are to be tied together to ensure that they remain together. Bars larger than 32 mm diameter are not to be bundled.

Other detailing requirements for reinforcements are given in latter chapters when the design of structural elements is taken up

1.5 LOADS

The various loads expected on a structure may be classified into the following groups:

- (i) Dead loads
- (ii) Imposed loads
- (iii) Wind loads
- (iv) Snow loads
- (v) Earthquake forces
- (vi) Shrinkage, creep and temperature effects, and
- (vii) Other forces and effects.

Dead Loads (DL)

Dead loads in a building includes the weight of all permanent constructions, like roofs, floors, walls, partition walls, beams, columns, balcony's, footing. These loads shall be assessed by estimating the quantity of each material and then multiplying it with the unit weight. The unit weights of various materials used in building constructions are given in the code IS 875 (part - 1) - 1987. It includes exhaustive list. For example, under the heading 'brick masonry', it has four types like common burnt clay bricks, engineering bricks, glazed bricks and pressed bricks. Under the heading plain concrete there are 10 groups. The commonly used values by the designers are listed in table 1.5.

Table 1.5 Unit weight of Important Building Materials Used by Designers

Sl. No.	Material	Unit Weight
1.	Plain concrete	24 kN/m ³
2.	Reinforced concrete	25 kN/m ³
3.	Brick masonry, cement plaster	20 kN/m ³
4.	Granite stone masonry	24 kN/m ³
5.	Asbestos cement sheets	0.130 kN/m ²

Imposed Loads (IL)

The loads which keep on changing from time to time are called as imposed loads. Common examples of such loads in a building are the weight of the persons, weights of movable partition, dust loads and weight of furnitures. These loads were formerly known as live loads. These loads are to be suitably assumed by the designer. It is one of the major load in the design. The minimum values to be assumed are given in IS 875 (part 2)—1987. It depends upon the intended use of the building. These values are presented for square metre of floor area. The code gives the values of loads for the following occupancy classification:

- (i) Residential buildings—dwelling houses, hotels, hostels, boiler rooms and plant rooms, garages.
- (ii) Educational buildings
- (iii) Institutional buildings
- (iv) Assembly buildings
- (v) Business and office buildings
- (vi) Mercantile buildings
- (vii) Industrial buildings, and
- (viii) Storage rooms.

The code gives uniformly distributed load as well as concentrated loads. The floors are to be investigated for both uniformly distributed and worst position of concentrated loads. The one which gives worst effect is to be considered for the design but both should not be considered to act simultaneously.

In a particular building, imposed load may change from room to room. For example in a hotel or a hostel building the loads specified are,

	<i>udl</i>	Concentrated load
(a) Living rooms and bed rooms	2 kN/m ²	1.8 kN
(b) Kitchen	3 kN/m ²	4.5 kN
(c) Dining rooms	4 kN/m ²	2.7 kN
(d) Office rooms	2.5 kN/m ²	2.7 kN
(e) Store rooms	5 kN/m ²	4.5 kN
(f) Rooms for indoor games	3 kN/m ²	1.8 kN
(g) Bath rooms and toilets	2 kN/m ²	—
(h) Corridors, passages, stair cases etc.	3 kN/m ²	4.5 kN

and (i) Balconies 4 kN/m² 1.5 kN concentrated at outer edge.

Some of the important values are presented in table 1.6, which are the minimum values and wherever necessary more than these values are to be assumed.

Table 1.6 Minimum Imposed Load to be Considered

Sl. No.	Occupancy	UDL Load	Concentrated
1.	Both rooms and toilets in all types of building	2 kN/m ²	1.8 kN
2.	Living and bed rooms	2 kN/m ²	1.8 kN
3.	Office rooms in		
	(i) Hostels, hotels, hospitals and business building with separate store	2.5 kN/m ²	2.7 kN
	(ii) In assembly buildings	3 kN/m ²	4.5 kN
4.	Kitchens in (i) Dwelling houses	2 kN/m ²	1.8 kN
	(ii) Hostels, hotels and hospitals	3 kN/m ²	4.5 kN
5.	Banking halls, class rooms, x-ray rooms, operation rooms	3 kN/m ²	4.5 kN
6.	Dining rooms in (i) educational buildings, institutional and mercantile buildings	3 kN/m ²	2.7 kN
	(ii) hostels and hotels	4 kN/m ²	2.7 kN
7.	Corridors, passages, stair cases in		
	(i) Dwelling houses, hostels and hotels	3 kN/m ²	4.5 kN
	(ii) Educational institutional and assembly buildings	4 kN/m ²	4.5 kN
	(iii) Mercantile buildings	5 kN/m ²	4.5 kN
8.	Reading rooms in libraries		
	(i) With separate storage	3 kN/m ²	4.5 kN
	(ii) Without separate storage	4 kN/m ²	4.5 kN
9.	Assembly areas in assembly buildings		
	(i) With fixed seats	5 kN/m ²	..
	(ii) Without fixed seats	5 kN/m ²	3.6 kN
10.	Store rooms in educational buildings	5 kN/m ²	4.5 kN
11.	Store room in libraries	6 kN/m ² for a height of 2.24 + 2 kN/m ² for every 1m additional height	4.5 kN
12.	Boiler rooms and plant rooms in		
	(i) hostels, hotels, hospitals, mercantile and industrial buildings	5 kN/m ²	4.5 kN
	(ii) Assembly & storage buildings	7.5 kN/m ²	4.5 kN

Imposed loads to be considered on various roofs are presented in table 1.7

Table 1.7 Imposed Loads on various Types of Roofs
(Table 2 of National Building code - 1983)

<i>Sl.No.</i>	<i>Type of Roof</i>	<i>Imposed Load Measured on Plan Area</i>	<i>Minimum Imposed Load Measured on Plan</i>
(i)	Flat, sloping or curved roof with slopes up to and including 10 degrees (a) Access provided	1.5 kN/m ²	3.75 kN uniformly distributed over any span of one metre width of the roof slab and 9 kN uniformly distributed over the span of any beam or truss or wall. 1.9 kN uniformly distributed over any span of one metre width of the roof slab and 4.5 kN uniformly distributed over the span of any beam of truss or wall. Subject to a minimum of 0.4 kN/m ²
	(b) Access not provided except for maintenance	0.75 kN/m ²	
(ii)	Sloping roof with slope greater than 10 degrees	For roof membrane sheets or purlins - 0.75 kN/m ² less 0.02 kN/m ² for every degree increase in slope over 10 degrees	Subject to a minimum of 0.4 kN/m ²
(iii)	Curved roof with slope of line obtained by joining springing point to the crown with the horizontal, greater than 10 degrees	(0.75 - 0.52 α ²) kN/m ² where α = h/l h = height of the highest point of the structure measured from its springing; and l = chord width of the roof if singly curved and shorter of the two sides if doubly curved. Alternatively, where structural analysis can be carried out for curved roofs of all slopes in a simple manner applying the laws of statistics, the curved roofs shall be divided into minimum 6 equal segments and for each segment imposed load shall be calculated appropriate of each segment as given in (i) and (ii)	Subject to a minimum of 0.4 kN/m ²

Note : 1 - The loads given above do not include loads due to snow, rain, dust collection, etc. The roof shall be designed for imposed loads given above or snow / rain load, whichever is greater.

Note : 2 - For special types of roofs with highly permeable and absorbent material, the contingency of roof material increasing in weight due to absorption of moisture shall be provided for.

However in a multi-storeyed buildings chances of full imposed loads acting simultaneously on all floors is very rare. Hence the code makes provision for reduction of loads in designing columns, load bearing walls, their supports and foundations as shown in table 1.8.

Table 1.8 Reductions in Imposed Loads on Floors in Design of Supporting Structural Elements

<i>Number of Floors (including the roof) to be carried by Member Under Consideration</i>	<i>Reduction in Total Distributed Imposed Load in Percent</i>
1	0
2	10
3	20
4	30
5 to 10	40
Over 10	50

Wind Loads

The force exerted by the horizontal component of wind is to be considered in the design of buildings. It depends upon the velocity of wind and shape and size of the building. Complete details of calculating wind load on structures are given in IS-875 (Part 3) - 1987. Brief idea of these provisions are given below:

(i) Using colour code, basic wind pressure ' V_b ' is shown in a map of India. Designer can pickup the value of V_b depending upon the locality of the building.

(ii) To get the design wind velocity V_z the following expression shall be used:

$$V_z = k_1 k_2 k_3 V_b$$

Where k_1 = Risk coefficient

k_2 = Coefficient based on terrain, height and structure size.

k_3 = Topography factor

(iii) The design wind pressure is given by

$$p_z = 0.6 V_z^2$$

where p_z is in N/m^2 at height Z and V_z is in m/sec . Up to a height of 30m, the wind pressure is considered to act uniformly. Above 30m height, the wind pressure increases.

Snow Loads

IS 875 (part 4) - 1987 deals with snow loads on roofs of the building. For the building to be located in the regions wherever snow is likely to fall, this load is to be considered. The snow load acts vertically and may be expressed in kN/m^2 or N/m^2 . The minimum snow load on a roof area or any other area above ground which is subjected to snow accumulation is obtained by the expression

$$S = \mu S_0$$

Where S = Design snow load on plan area of roof.

μ = Shape coefficient, and

S_0 = Ground snow load.

Ground snow load at any place depends on the critical combination of the maximum depth of undisturbed aggregate cumulative snow fall and its average density. These values for different regions may be obtained from Snow and Avalanches Study Establishment Manali (HP) or Indian Meteorological Department Pune. The shape coefficient depends on the shape of roofs and for some of the common shapes the code gives these coefficients. When the slope of roof is more than 60° this load is not considered.

It may be noted that roofs should be designed for the actual load due to snow or for the imposed load, whichever is more sever.

Earthquake Forces

Earthquake shocks cause movement of foundation of structures. Due to inertia additional forces develop on super structure. The total vibration caused by earthquake may be resolved into three mutually perpendicular directions, usually taken as vertical and two horizontal directions. The movement in vertical direction do not cause forces in superstructure to any significant extent. But movement in horizontal directions cause considerable forces.

The intensity of vibration of ground expected at any location depends upon the magnitude of earthquake, the depth of focus, the distance from the epicenter and the strata on which the structure stands.

The response of the structure to the ground vibration is a function of the nature of foundation soil, size and mode of construction and the duration and intensity of ground motion. IS:1983 – 1984 gives the details of such calculations for structures standing on soils which will not considerably settle or slide appreciably due to earthquake. The seismic accelerations for acceleration due to earthquake and acceleration due to gravity. For the purpose of determining the seismic forces, India is divided into five zones. Depending on the problem, one of the following two methods may be used for computing the seismic forces:

(a) Seismic coefficient method

(b) Response spectrum method

The details of these methods are presented in IS 1983 code and also in National Building Code of India. After the Gujarat earthquake (2000) Government of India has realized the importance of structural designs based on considering seismic forces and has initiated training of the teachers of technical institution on a large scale (NPTEE). In this book designs are based on normal situations and hence earthquake forces are not considered.

There are large number of cases of less importance and relatively small structures for which no analysis be made for earthquake forces provided certain simple precautions are taken in the construction. For example

(i) Providing bracings in the vertical panels of steel and R.C.C. frames.

(ii) Avoiding mud and rubble masonry and going for light materials and well braced timber framed structures.

Other Forces and Effects

As per the clause 19.6 of IS 456 – 2000, in addition to above load discussed, account shall be taken of the following forces and effects if they are liable to affect materially the safety and serviceability of the structure:

- (a) Foundation movement (See IS 1904)
- (b) Elastic axial shortening
- (c) Soil and fluid pressure (See IS 875, Part 5)
- (d) Vibration
- (e) Fatigue
- (f) Impact (See IS 875, Part 5)
- (g) Erection loads (See IS 875, Part 2) and
- (h) Stress concentration effect due to point load and the like.

1.6 LOAD COMBINATIONS

A judicious combination of the loads is necessary to ensure the required safety and economy in the design keeping in view the probability of

- (a) their acting together
- (b) their disposition in relation to other loads and severity of stresses or deformations caused by the combination of various loads.

The recommended load combinations by national building are codes

1.	DL	7.	DL + IL + EL
2.	DL + IL	8.	DL + IL + TL
3.	DL + WL	9.	DL + WL + TL
4.	DL + El	10.	DL + EL + TL
5.	DL + TL	11.	DL + IL + WL + TL
6.	DL + IL + WL	12.	DL + IL + EL + TL

where DL = dead load IL = imposed load
 WL = wind load EL = earthquake load
 and TL = temperature load.

Note: When snow load is present on roofs, replace imposed load by snow load for the purpose of above load combinations.

1.7 STRUCTURAL ANALYSIS

Structural analysis is necessary to determine the stress resultants like bending moment, shear force, torsional moment, axial forces acting at various cross section of structural elements. IS 456 permits the analysis of all structures by linear elastic theory. For structural analysis one can use classical methods. Code also permit use of approximate methods like substitute frame method, use of coefficients for the continuous beams and slabs.

Numerical methods also may be used for the analysis. Finite element method is becoming a popular method of analysis, since standard commercial packages are available. This method being versatile any complex structure may be analyzed with acceptable accuracy. Some of the popular packages are STAADPRO, GTSTRU DL, NISA - CIVIL, NASTRAN and ANSYS.

1.8 METHODS OF RCC DESIGN

The aim of design is to decide the size of the member and provide appropriate reinforcement so that the structures being designed will perform satisfactorily during their intended life. With an appropriate degree of safety the structure should

- (i) sustain all loads
- (ii) sustain the deformations during and after construction
- (iii) should have adequate durability and
- (iv) should have adequate resistance to misuse and fire.

Various methods of R.C.C. designs can be grouped into experimental and analytical methods.

In civil engineering **experimental methods** of designs have superseded the **analytical methods**. Whenever new materials have been developed, they have been tested and used on experimental basis. Once they have been found suitable theoretical methods have been developed to economize. If the structures are too complex model studies are carried out and then prototypes are built. However this method of design is time consuming and cannot be accepted for the design of each and every structure.

Analytical methods are based on identifying failure criteria based on material properties. Expected loads quantified, analysis carried out and then based on failure criteria safe designs are found. Since there are limitations in estimating design loads, material behaviour and analytical methods, working condition is kept at a fraction of failure conditions. The design philosophies used in R.C.C. are listed below in the order of their evolutions and then they are briefly explained:

- (i) Working stress method (WSM)
- (ii) Load factor method (LFM) or Ultimate load method (ULM), and
- (iii) Limit state method (LSM)

Working Stress Method (WSM)

This method of design was evolved around the year 1900. This method was accepted by many national codes. India's code IS 456-1953 was based on this method. It was revised in 1957 and 1964. This method is based on **elastic theory** of R.C.C. sections. The following assumptions are made in this method:

- (i) At any cross section, plane section before bending remains plane even after bending.
- (ii) All tensile stresses are taken by reinforcements and none by concrete.
- (iii) The stress strain relation, under working loads, is linear both for steel and concrete.
- (iv) The modular ratio between steel and concrete remains constant and is given by

$$m = \frac{E_s}{E_m} = \frac{280}{3\sigma_{cbc}}$$

Where σ_{cbc} is permissible compressive stress in bending.

Permissible stress in concrete is defined as ultimate stress divided by a factor of safety. In concrete a factor of safety upto 3 is used. In case of steel, the permissible stress is defined as yield stress or 0.2 per cent proof stress divided by factor of safety. Since steel is more reliable material, factor of safety used is 1.75 to 1.85 only. Based on **elastic theory** and assuming that the bond between steel and concrete is perfect stresses are estimated in reinforced cement concrete. The designer will aim at keeping these stresses as close to permissible stresses as possible but without exceeding them.

The Limitation of this Method are

- (i) It assumes stress strain relation for concrete is constant, which is not true.
- (ii) It gives the impression that factor of safety times the working load is the failure load, which is not true. This is particularly so in case of indeterminate structures. In these structures there will be redistribution of forces as plastic hinges are formed at critical sections.
- (iii) This method gives uneconomical sections.

The advantages of this method are

- (i) It is simple
- (ii) Reasonably reliable and
- (iii) As the working stresses are low, the serviceability requirements are automatically satisfied and there is no need to check them.

However this method has been deleted in IS 456 – 2000, but the concept of this method is retained for checking serviceability states of deflections and cracking. Hence knowledge of this method is essential and IS 456 – 2000 gives it in appendix. In this book, this method is briefly explained in Appendix B and few problems have been solved.

Load Factor Method (LFM) or Ultimate Load Method (ULM)

In this method ultimate load is used as design load and the collapse criteria used for the design. Ultimate load is defined as load factor times the working load. Hence it gives better concept of load carrying capacity of the structure. Its salient features are:

1. Uses actual stress strain curve and ultimate strain as failure criteria.
2. Redistribution of forces is accounted since it works in the plastic region.
3. It allows varied selection of load factors, a lower value for loads known with more certainty like dead load and higher value for a less certain loads like live load and wind loads.

This method gives very economical sections. However it leads to excessive deformation and cracking. This phenomenon is more predominant when high strength deformed bars are used. Thus this method failed to satisfy the serviceability and durability criteria. To overcome these problems codes started adopting load factor method (LFM) in which load factors were modified. A load factor of 2 was used for design. Additional factor of safety of 1.5 was used for designed concrete mixes for calculating the permissible stresses to control serviceability requirement.

As more and more research continued to investigate the problems related with ultimate load method it was felt instead of repairing this method there is need for comprehensive method to take care of design requirements from strength and serviceability criteria. This gave rise to limit state method and all codes replaced this method by limit state method. Hence there is no need to make a separate study of this method.

Limit State Method (LSM)

This is a comprehensive method which takes care of the structure not only for its safety but its fitness throughout the period of service of the structure. This method is thoroughly explained in chapters II and III and many structural elements are designed in the other chapters.

Principles of Limit State Design

2.1 PHILOSOPHY OF LIMIT STATE DESIGN

Aim of a design is to see that the structure built is safe and it serves the purpose for which it is built. A structure may become **unfit** for use not only when it collapses but when it violates the serviceability requirements of deflections, cracking etc. In this method various limiting conditions are fixed to consider a structure as fit. At any stage of its designed life (120 years for permanent structure), the structure should not exceed these limiting conditions. The design is always based on probable load and probable strength of materials. These are to be estimated by **probabilistic approach**. The safety factor for each limiting condition may vary depending upon the risk involved. It is not necessary to design every structure to withstand exceptional events like wars and earthquake. In this design risk based evaluation criteria is included. Thus the philosophy of limit state design method is to see that the structure remains fit for use throughout its designed life by remaining within the acceptable limits of safety and serviceability requirements based on the risks involved. The R.C. structure should be safe and durable.

A durable concrete is one that performs satisfactorily in the working environment during its anticipated exposure conditions during service. The factors influencing durability include (clause 8. IS-456-2000):

- (a) The environment
- (b) The cover to embedded steel
- (c) The type and the quality of constituent materials
- (d) The cement content and water cement ratio of the concrete
- (e) Workmanship, to obtain full compaction and efficient curing ; and
- (f) The shape and size of the member

One of the main characteristics influencing the durability of concrete is its permeability to the ingress of water, oxygen, carbon dioxide, chloride, sulphate and other deleterious substances. With normal - weight aggregates a suitably low permeability is achieved by having an adequate cement content, sufficiently low free water / cement ratio, by ensuring complete compaction and adequate curing of concrete. IS 456-2000 gives lot of emphasis on durability aspect and exhaustively deals it under clause 8.

2.2 LIMIT STATES

The various limit states to be considered in design may be grouped into the following three major categories:

- (i) Limit state of collapse
- (ii) Limit state of serviceability, and
- (iii) Other limit states.

(i) Limit State of Collapse

A structure is said to have collapsed if

- (a) Material at one or more sections ruptures
- (b) The buckling takes place, or
- (c) Overturning takes place.

The following ultimate states are to be considered in the design:

- (a) Tension
- (b) Compression
- (c) Flexure
- (d) Shear and
- (e) Torsion

The design should be such that, the resistance at every section to above stress resultants shall not be less than the appropriate value at that section produced by the probable most unfavourable combination of loads on the structure using appropriate partial safety factors.

(ii) Limit States of Serviceability

The deflection and crack width are the two major criteria of serviceability.

(a) Limit State of Deflections:

The deflection of the structure under service load conditions should be within the acceptable limits. The adverse effects of excessive deflections are :

1. It creates feeling of lack of safety.
 2. Aesthetic view is spoiled.
 3. Leads to deformation of door and window frames and cracking of floor finishing materials.
 4. Creates ponding of water on roof slabs.
 5. In machines, it results into misalignments affecting the functioning of the machine.
- IS-456-2000 specifies limit states for deflection for various conditions. The limit state condition of deflection may be satisfied by any one of the following two methods.

1. **Empirical Method:** Since most important factor that controls the deflection is span / depth ratio, deflection can be controlled by the span / depth ratio as specified by the codes.
2. **Theoretical Method:** Deflections can be calculated by theoretical methods and controlled by suitable dimensioning of the structure.

(b) Limit State of Cracking:

The cracks in concrete results into the following adverse effects:

- (i) Mars the appearance.
- (ii) Creates the feeling of lack of safety.
- (iii) Creates leakage problems.
- (iv) Leads to corrosion problems affecting the durability.
- (v) Reduces stiffness resulting into excessive deflections.
- (vi) Creates maintenance problems.

However cracks in concrete are unavoidable. As the tensile strength of concrete is very low the cracks in the tensile zone appear even at low loads. The accepted limits of cracks widths under service load conditions have been specified by the code keeping in mind that cracking should not affect the appearance or durability of the structure. The accepted limits of cracks vary with the type of the structure and environmental conditions. The crack widths may be kept within the acceptable limit by any one of the following methods:

- (a) **Empirical Method:** By strictly following the bar detailing rules as specified in the codes.
- (b) **Theoretical Method:** The probable crack width is calculated and checked.
- (iii) **Other Limit States:** Structures may be required to withstand unusual and special loads. For such special structures additional relevant limit states shall be considered. Some of such limit states are listed below:
 - (a) Vibration
 - (b) Fire resistance
 - (c) Chemical and environmental actions
 - (d) Accidental or catastrophic collapse

2.3 CHARACTERISTIC LOAD

Structures have to carry dead load and live loads. The **maximum working load** that the structure has to withstand and for which it is to be designed is called characteristic loads. The characteristic loads are to be based on statistical analysis. As per the code the characteristic loads means the value of the load above which not more than 5 per cent results are expected to fall. For the sake of simplicity, it may be assumed that the variation of these loads and strength follow normal distribution laws. Normal distribution means distribution symmetric about mean value (Ref. Fig. 2.1).

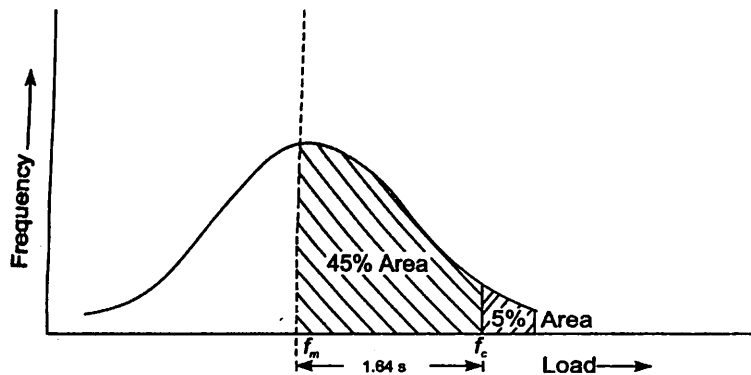

Fig. 2.1 Characteristic Load.

As the load should be more than the average load obtained from statistic,

$$\text{Characteristic Design Load} = \text{Mean Load} + k S$$

where S is the standard deviation, and the value of k is taken as corresponding to 5 per cent probability and for normal distribution it is equal to 1.64. Since data are not available to express loads in statistical terms, IS 456-2000 permits use of the values given in IS-875 as characteristic loads.

2.4 CHARACTERISTIC STRENGTH

The strength that one can safely assume for the material (steel and concrete) are termed as characteristic strength. This is to be based on the statistical analysis of test results below which not more than 5 per cent of test results are expected. In this case also normal distribution is assumed (Ref. Fig. 2.2). As the design strength should be less than mean strength,

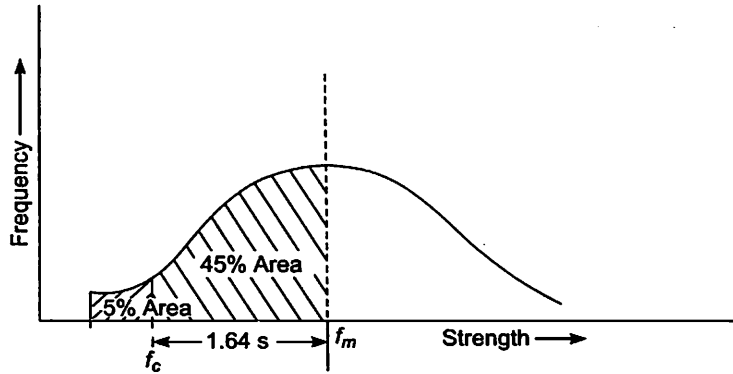

Fig. 2.2 Characteristic strength

$$\text{Characteristic strength} = \text{Mean strength} - k S$$

$$(f_k) \qquad \qquad \qquad (f_m)$$

In this case also $k = 1.64$ and 'S' in standard deviation.

For concrete characteristic strength is compressive strength of 150 mm cube of 28 days in N/mm^2 , below which not more than 5 percent cubes give the results. Concrete grades are specified based on this strength.

Characteristic strength for steel is also to be based on statistical analysis of tests results.

However as quality controls in steel manufacturing units is good, IS 456 permits use of minimum guaranteed yield strength or 0.2 per cent proof strength as characteristic strength of steel.

Example 2.1 If standard deviation is 4 N/mm^2 , what should be the mean strength of concrete, if desired characteristic strength is 20 N/mm^2 ?

Solution.

$$f_k = f_m - 1.64 S$$

$$\therefore f_m = f_k + 1.64 S$$

$$= 20 + 1.64 \times 4$$

$$= 26.4 \text{ N/mm}^2.$$

2.5 PARTIAL SAFETY FACTORS

Noting the importance of safety in civil engineering structures and uncertainties involved in analysis, design, construction practices and material qualities appropriate factor of safety in the design is required. Hence the design loads and design strength of materials are not same as characteristic loads and strength. IS code specifies separate partial safety factors for the loads and strength of materials.

2.5.1 Partial Safety Factors for Loads.

Partial safety factor for load is defined as,

$$\gamma_f = \frac{F_d}{F}$$

Where F_d – design load
and F – characteristic load.

Thus design load $F_d = F_{\gamma_f}$

The design load is called as factored load also. Partial safety factor is different for different loading and different limiting cases considered. The values specified by IS 456 - 2000 are as presented in table 2.1.

Table 2.1 Values of Partial Safety Factors γ_f for Loads (Table 18 of IS 456)

Sl. No.	Load combination (1)	Limit State of collapse			Limit State of Serviceability		
		DL	IL	WL	DL	IL	WL
1	DL + IL	1.5	1.5	—	1.0	1.0	—
2	DL + WL	0.9	—	1.5	1.0	—	1.0
	Case (i) DL Contributing to Stability (ii) DL assisting over turning						
3	DL + IL + WL	1.2	1.2	1.2	1.0	0.8	0.8

Notes: 1. If earthquake effect is to be considered, substitute EL for WL.

2. The γ_f values given above for the limit state of serviceability are applicable only for short term effects while assessing long terms effects due to creep, consider only the dead load and part of IL likely to be permanent.

Example 2.2. A one way slab has effective span 3.6m and is 150mm thick. The live load expected on it is 3 kN/m². Determine

- (i) Design moment
- (ii) Design shear, and
- (iii) Loads for checking serviceability.

Solution.

Characteristic Loads

Unit weight of reinforced concrete = 25 kN/m³

$$\therefore DL = 0.150 \times 1 \times 1 \times 25 = 3.75 \text{ kN/m}^2$$

$$IL = 3 \text{ kN/m}^2$$

Design Load = $w_u = 1.5 (DL + IL)$

(Factored load) = $1.5 (3.75 + 3) = 10.125 \text{ kN/m}^2$

Design (factored) moment per metre width of slab

$$M_u = \frac{w_u L^2}{8} = 10.125 \times \frac{3.6^2}{8} = 16.40 \text{ kN-m}$$

Design (factored) shear per metre width of slab

$$V_u = \frac{w_u L}{2} = \frac{10.125 \times 3.6}{2} = 18.225 \text{ kN}$$

Ans.

Load for serviceability condition:

$$W_s = 1.0 (DL + IL) = 1.0 (3.75 + 3) = 6.75 \text{ kN}$$

Ans.

Example 2.3. A column of 3.6m high is subjected to the following loads:

Total DL = 30 kN

Total IL = 80 kN

Wind load = 4kN/m height.

Determine the design loads for the limit state of

- (a) Strength
- (b) Serviceability.

Solution.

Total wind load = $4 \times 3.6 = 14.4 \text{ kN}$, with its centered at $\frac{3.6}{2} = 1.8 \text{ m}$ from the ends. This is horizontal load.

(a) Design load from strength consideration for various load combinations:

(i) Dead and live load case

$$P = 1.5 (DL+IL) = 1.5 (30+80) = 165 \text{ kN. (vertical)}$$

(ii) Dead load and wind load:

In this case dead load assists overturning

$$\therefore \text{Vertical load } P = 0.9 DL = 0.9 \times 30 = 27 \text{ kN}$$

$$\text{Horizontal load } H = 1.5 WL = 1.5 \times 14.4 = 21.6 \text{ kN}$$

(iii) Dead load + Imposed load + wind load

$$\text{Vertical load } P = 1.2 (DL + IL) = 1.2 (30 + 80) = 132 \text{ kN.}$$

$$\text{Horizontal load } 1.2 WL = 1.2 \times 14.4 = 17.28 \text{ kN}$$

(b) Design load for serviceability considerations:

(i) Dead load and Imposed load:

$$\text{Vertical } P = 1.0 (DL + IL) = 1.0 (30+80) = 110 \text{ kN.}$$

(ii) Dead load and wind load:

$$\text{Vertical load, } P = 1.0 WL = 30 \text{ kN}$$

$$\text{Horizontal load, } H = 1.0WL = 14.4 \text{ kN.}$$

(iii) Dead load + Imposed load + Wind load:

$$\text{Vertical load } P = 1.0 DL + 0.8 IL = 1 \times 30 + 0.8 \times 80 = 94 \text{ kN.}$$

$$\text{Horizontal load } H = 0.8 WL = 0.8 \times 14.4 = 11.52 \text{ kN}$$

2.5.2 PARTIAL SAFETY FACTORS FOR MATERIALS

Partial safety factor for the material is defined as

$$\gamma_m = \frac{f}{f_d} \quad \text{i.e.} \quad f_d = \frac{f}{\gamma_m}$$

Where f – characteristic strength of the material
and f_d – design strength of material.

The partial safety factor is different for different materials and limit states. The values recommended by IS code are shown in Table 2.2.

**Table 2.2 Partial Safety Factors For Material Strength
(Clause 36.4. 2 in IS 456-2000)**

Material	Limit State of	
	Collapse	Deflection
Concrete	1.5	1.0
Steel	1.15	1.0

2.6 IDEALISED STRESS STRAIN CURVES

In chapter I (Figs. 1.1 and 1.2) we have seen actual stress strain relation for concrete and steel. To simplify the analysis, stress strain curves have been idealized as discussed below:

(a) For Concrete

Throughout the world, irrespective of grade of concrete, only one stress strain curve is accepted. This is as shown in Fig. 2.3. The idealized curve is a parabola for the initial ascending part and is followed by a horizontal straight line terminating at a prescribed ultimate strain of 0.0035, however codes differ with respect to the values of ϵ_{co} at which the strength becomes constant. In IS code it is taken as 0.002. Hence according to IS code.

if

$$x = 0.0035$$

$$x_1 = \frac{0.002}{0.0035} = 0.57x, \text{ and}$$

$$x_2 = 0.43 x.$$

where x_1 – Length of parabolic curve and
 x_2 – Length of rectangular portion

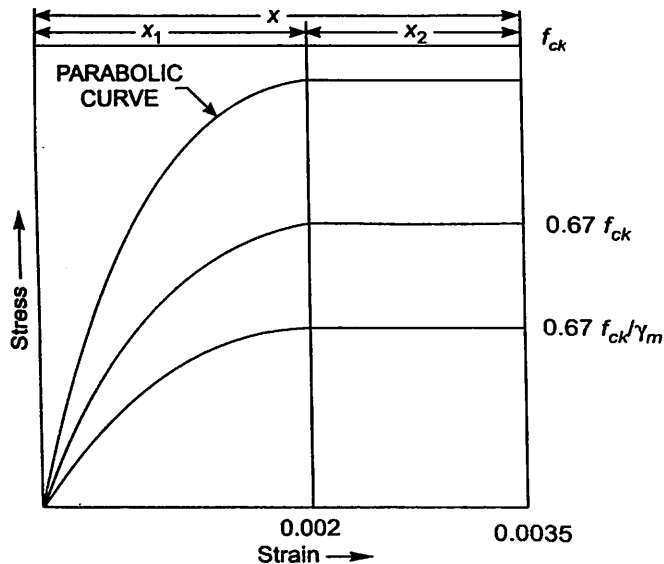

Fig 2.3 Idealized stress strain curve concrete

The characteristic strength is based on the tests on cubes cast at laboratories. In actual structures it will be difficult to achieve the same. IS code recommends that the strength achieved in the structures may be taken as only $0.67 \left(\frac{2}{3} rd \right)$ times the strength of the cube.

Hence the theoretical stress strain curve of the concrete in the design of structure is correspondingly reduced by the factor 0.67 as shown in Fig. 2.3.

In addition to the above, code recommends use of partial material safety factor of 1.5 for the concrete. Hence the stress strain curve for concrete used by designer is as shown in Fig 2.3 (Fig. 21 in IS 456)

(b) Idealised Stress Strain Curve for Steel

The stress strain curve for steel is assumed to be same in tension as well as in compression. For both mild steel bars as well as cold worked deformed bars, young's modulus $E_s = 2 \times 10^5 \text{ N/mm}^2 = 200 \text{ kN/mm}^2 = 200 \text{ GPa}$. Representative stress strain curves for mild steel and cold worked deformed bars are as shown in Fig. 2.4 (Fig. 23 in IS 456). The partial safety factor prescribed is 1.15.

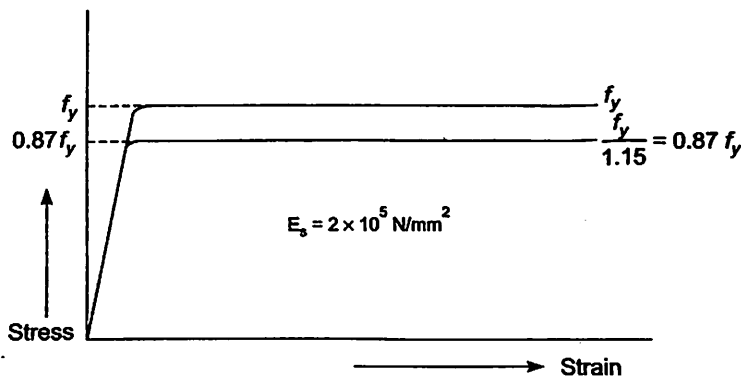
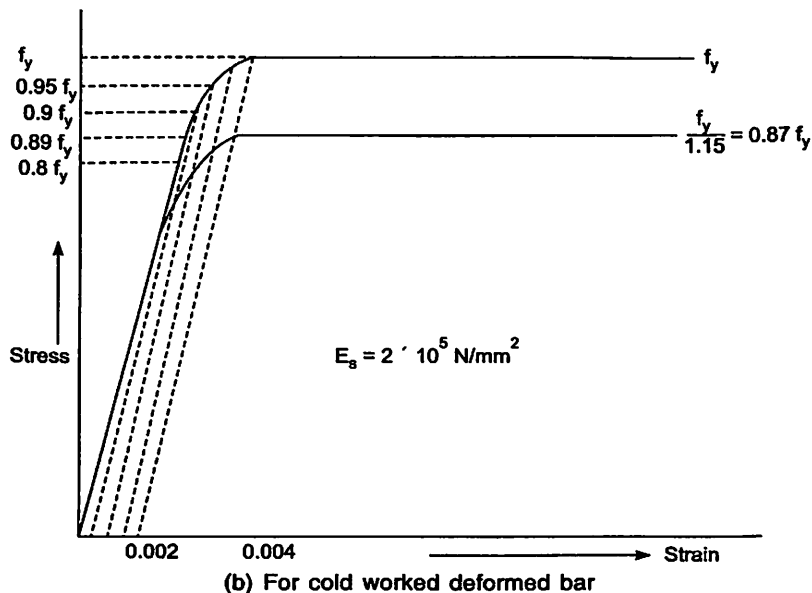

Fig. 2.4 (a) For mild steel bars (Bars with definite yield point)



(b) For cold worked deformed bar

Fig. 2.4 Idealized stress-strain curve for steel

2.7. SUMMARY OF DESIGN BY LIMIT STATE METHOD

- (i) **Characteristic loads and characteristic strength** are recommended based on statistical analysis.
- (ii) Separate **partial safety factors** for loads and strength are to be used to get design loads and design strength.
- (iii) Based on probabilistic approach load combinations are to be used to find design stress resultants.
- (iv) The design is to be based on limit states of safety and serviceability. These limit states to be checked should be those occurring at any stage of the life of the structure. Thus not only strength but durability is also major consideration in the limit state of design.
- (v) However to simplify mathematical computations stress strain curves for concrete and steel are idealized to some extent.

QUESTIONS

1. Explain the principles of
 - (a) Working stress method
 - (b) Ultimate load method and
 - (c) Limit state method of design.
2. How limit state method differs from working stress method?
3. How limit state method differs from ultimate load method?
4. Explain the terms
 - (a) Characteristic strength and characteristic loads
 - (b) Partial safety factors
5. Distinguish between
 - (a) Factor of safety and partial safety factor
 - (b) Characteristic load and design load. (Factored load).
6. Write short notes on actual and idealized stress strain curve for
 - (a) Concrete
 - (b) Steel

Flexural Strength of R.C. Sections

3.1 INTRODUCTION

Amount of longitudinal steel (main bars) to be provided in a beam depends upon the consideration of bending moment. If this steel is provided only on tensile side in the beam section, it is called **singly reinforced section**. If the steel is provided in both tensile and compression side, it is called **doubly reinforced section**. In this chapter various assumptions made in the design are presented and then the terms '**balanced, under reinforced and over reinforced**' are explained. The state of stress across a section at the limit state of collapse in flexure is discussed and the method of finding **flexural strength** (moment carrying capacity in limiting state) is explained. Then it is extended to **flanged beams** like T and L beams and also for the doubly reinforced sections. For all this IS 456 codal provisions are used. The procedure is illustrated with examples.

3.2 ASSUMPTIONS

IS 456-2000 permits the following assumptions:

1. Plane section normal to the axis remains plane even after bending. It means the strain diagram across the depth of the cross section is linear as shown in Fig.3.1.

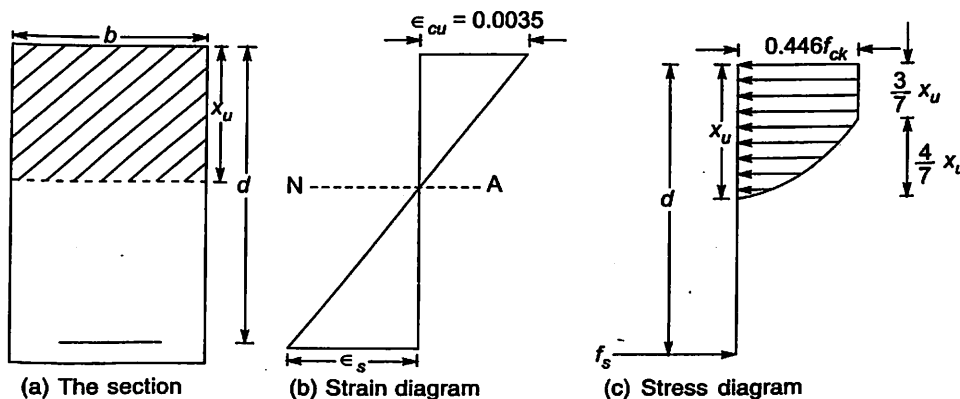

Fig. 3.1

2. At limiting state, the maximum strain in concrete, which occurs at outermost compression fibre is 0.0035.
3. The stress strain curve for concrete is having parabolic shape upto 0.002 strain and then constant upto limit state of 0.0035. However IS code do not prevent using other shapes like rectangle, trapezoidal which result in prediction of strength in substantial agreement with the result of the tests.

For design purpose, the compressive strength in the structure (size effect) may be assumed to be 0.67 times the characteristic strength. In addition to this the partial safety factor γ_m may be taken as 1.5. It means the maximum compressive strength in

the extreme fibre of the section will be $\frac{0.67}{1.5} f_{ck} = 0.446 f_{ck}$ or it may be taken as $0.45 f_{ck}$

also. The stress diagram assumed in the beam is as shown in Fig. 3.1 (c).

4. The tensile strength of concrete is ignored.
5. The stress in the steel shall correspond to the strain ϵ_s (ref. Fig. 3.1 and Fig. 2.4) in steel. For design purpose a partial safety factor of 1.15 is used; hence the maximum

stress in steel is limited to $\frac{f_y}{1.15} = 0.87 f_y$.

6. The maximum strain in the tensile reinforcement at failure shall not be less than

$$\frac{f_y}{1.15 E_s} + 0.002, \text{ i.e. } 0.87 \frac{f_y}{E_s} + 0.002,$$

where

f_y = Characteristic strength of steel

and

E_s = modulus of elasticity of steel

Actually this value correspond to beginning of flat portion in idealized stress strain curve for steel as shown in Fig. 3.2

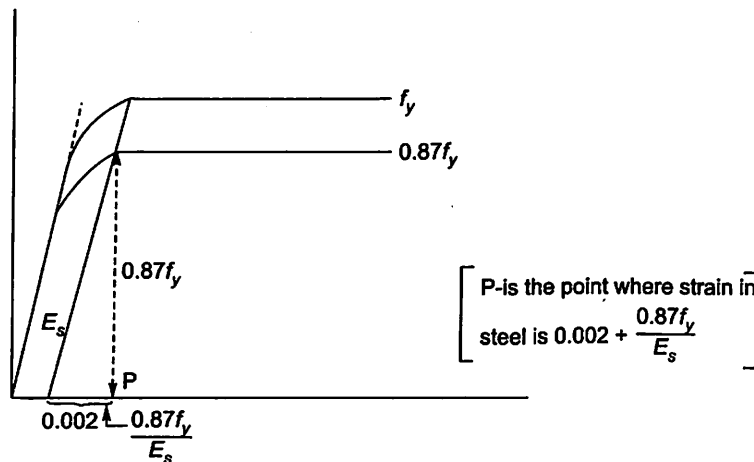
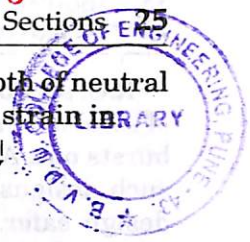

Fig. 3.2

3.3 BALANCED, UNDER REINFORCED AND OVER REINFORCED SECTIONS

In bending, strain varies linearly across the depth of the cross section of the member. One edge of the beam is in maximum compression and the other edge is in maximum tension. Hence somewhere across the depth, there is an axis where strain is zero. This axis is called



neutral axis. Depth of this axis from the maximum compression fibre is called depth of neutral axis and is denoted by x_u (Ref. Fig. 3.3). In limiting case maximum compressive strain in

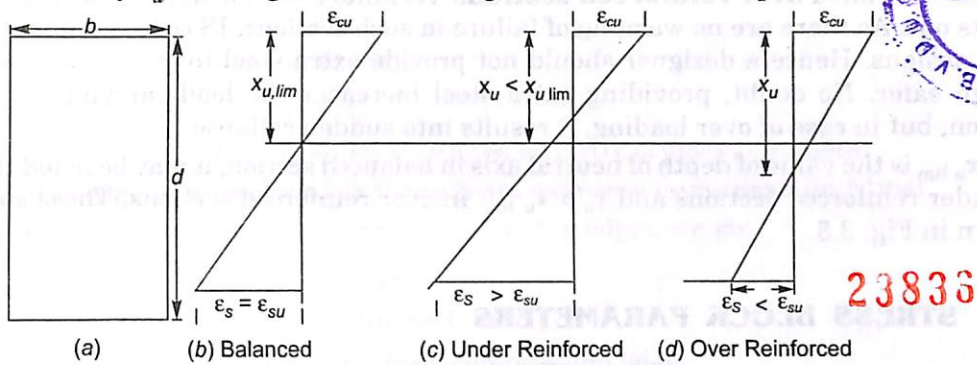

Fig. 3.3

concrete is 0.0035 corresponding strain in steel is

$$\epsilon_s = \frac{d - x_u}{x_u} 0.0035 \quad 3.1$$

From stress strain curve (Fig. 3.3) we find that when this value exceeds $\frac{0.87f_y}{E_s} + 0.002$ the stress in steel is yield stress f_y .

A section is called **balanced section** if for the same applied moment the strain in concrete and the strain in steel reach their limiting values simultaneously. In other words, in balanced sections maximum compressive strain ϵ_c in concrete reaches 0.0035 when the tensile strain in steel reaches its limiting value of

$$\epsilon_{su} = \frac{0.87f_y}{E_s} + 0.002 \quad 3.2$$

Sections in which tensile strain reaches yield strain of $0.002 + \frac{0.87f_y}{E_s}$ earlier to compressive strain in concrete reaching the limiting value of 0.0035, are called **under reinforced section**. In these cases as moment increases, first steel reaches yield strain. The stress in steel remains same (f_y) but strain goes on increasing. When the moment corresponding to 0.0035 strain in concrete is reached, concrete is crushed and failure takes place. The excess strain in steel beyond $\frac{0.87f_y}{E_s} + 0.002$ amounts to considerable cracks in concrete. The deflection will increase. They serve as a warning to the user and one can take precautions to avoid disaster. Hence IS Code specifies that the maximum strain in tension reinforced shall not be less than $\frac{0.87f_y}{E_s} + 0.002$. In other words, IS code prefers design of under reinforced sections and at the most it can be a balanced section. This type of failure in under reinforced section is called **primary tensile failure**.

R.C. sections in which the limiting strain in concrete is reached earlier than the yield strain of steel are called **over reinforced sections**. At failure steel is not yet yielded and concrete bursts out. As there are no warning of failure in such sections, IS code recommends avoiding such designs. Hence a designer should not provide extra steel to get the feeling of making design safer. No doubt, providing extra steel increases the load carrying capacity of the section, but in case of over loading, it results into sudden collapse.

If $x_{u \text{ lim}}$ is the value of depth of neutral axis in balanced section, it may be noted that $x_u < x_{u \text{ lim}}$ in under reinforced sections and $x_u > x_{u \text{ lim}}$ in over reinforced sections. These situations are shown in Fig. 3.3.

3.4 STRESS BLOCK PARAMETERS

The diagram showing the distribution of compressive stress in concrete across the depth x_u of the section is termed as '**stress block**'. Since the strain diagram is linear over this depth x_u , the shape of the stress block is the same as the idealized stress-strain curve of concrete. It has zero stress at neutral axis. It varies parabolically upto a height of $\frac{4}{7} x_u$ i.e., $\left[\frac{0.002}{0.0035} x_u \right]$ and has constant value equal to the design stress of $0.446 f_{ck}$ i.e., $\left(0.67 \times \frac{1}{1.5} f_{ck} \right)$ for the $\frac{3}{7} x_u$ i.e., $\left[\frac{0.0035 - 0.002}{0.0035} x_u \right]$. The shape of stress block is as shown in Fig. 3.4.

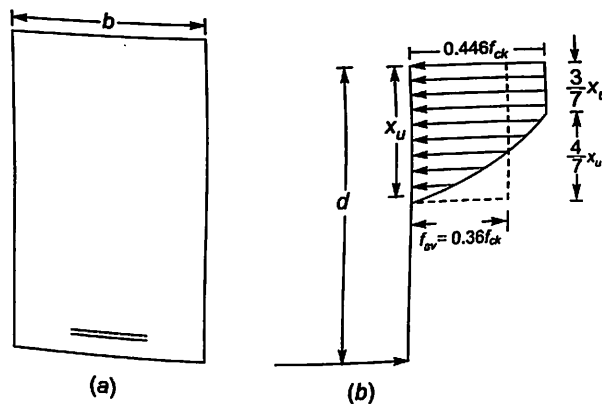

Fig. 3.4 Stress Block

Area of stress block: It may be found as explained below:

Area A of stress block = Area of rectangular portion + Area of parabolic portion

$$= 0.446 f_{ck} \times \frac{3}{7} x_u + \frac{2}{3} \times 0.446 f_{ck} \times \frac{4}{7} x_u$$

$$= 0.361 f_{ck} x_u$$

$$\approx 0.36 f_{ck} x_u \quad (\text{as recommended by IS code})$$

Now we look at $0.36 f_{ck}$ as the average stress over the depth x_u (ref. Fig. 3.4)

Area of stress block $= f_{av} x_u$

Then compressive force on the section,

$$\begin{aligned} C &= b x_u f_{av} \\ &= b x_u 0.36 f_{ck} \\ &= k_1 f_{ck} b x_u \end{aligned} \quad 3.4$$

where $k_1 = 0.36$ and is defined as a stress block parameter

Distance of centre of compressive force from extreme compression fibre:

Taking moment about extreme compression edge (top edge), we get

$$C \bar{x} = C_1 x_1 + C_2 x_2 \quad 3.5$$

where C = total compressive force on the section

\bar{x} = Distance of centre of gravity from compression edge

C_1 = Compressive force corresponding to rectangular portion of stress block

x_1 = Distance of centroid of c_1 from top fibre

C_2 = Compressive force corresponding to parabolic portion of stress block

x_2 = Distance of centroid of c_2

Now,
$$C = 0.36 f_{ck} b x_u$$

$$A_1 = 0.446 f_{ck} b \frac{3}{7} x_u$$

$$x_1 = \frac{1}{2} \times \frac{3}{7} x_u = \frac{3}{14} x_u$$

$$A_2 = \frac{2}{3} \times 0.446 f_{ck} b \times \frac{4}{7} x_u,$$

and

$$x_2 = \frac{3}{7} x_u + \frac{3}{8} \left(\frac{4}{7} x_u \right),$$

since distance of parabola of depth 'a' from wider end is $\frac{3}{8} a$

$$= \frac{3}{7} (1 + 0.5) x_u = \frac{4.5}{7} x_u$$

Hence we get,

$$0.36 f_{ck} b x_u \bar{x} = 0.446 f_{ck} b \frac{3}{7} x_u \times \frac{3}{14} x_u + \frac{2}{3} \times 0.446 f_{ck} \times b \frac{4}{7} x_u \times \frac{4.5}{7} x_u$$

$$\therefore \bar{x} = 0.417 x_u \approx 0.42 x_u \quad (\text{As per IS 456})$$

$$= k_2 x_u$$

3.6

where $k_2 = 0.42$ is another important parameter of the stress block.

3.5 DEPTH OF NEUTRAL AXIS

Beams are assumed to fail in bending when the strain in concrete reaches limiting compression strain of $\epsilon_{cu} = 0.0035$. But in all cases of design tensile strain in steel need not be equal to

limiting strain $\epsilon_{su} = 0.002 + \frac{0.87 f_y}{E_s}$. It can be less or more than it. However designs with $\epsilon_s < \epsilon_{su}$

(over reinforced sections) are to be avoided. Hence for all cases

$$\text{total compression} \quad C = 0.36 f_{ck} b x_u$$

$$\text{and total tension} \quad T = f_s A_{st}$$

where f_s is the stress in steel corresponding to strain of 0.0035 in concrete [note maximum design value of $f_s = 0.87 f_y$]

Equilibrium requirement in horizontal direction gives (Fig. 3.5) $C = T$

$$0.36 f_{ck} b x_u = f_s A_{st}$$

$$\text{or} \quad \frac{x_u}{d} = \frac{f_s A_{st}}{0.36 f_{ck} b d} \quad 3.7$$

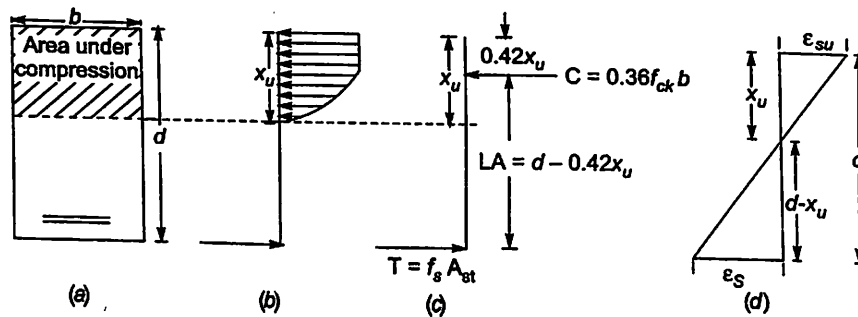

Fig. 3.5

Limiting Depth of NA : (NA for balanced section)

From strain diagram [Fig. 3.5 (d)]

$$\frac{\epsilon_s}{d - x_u} = \frac{0.0035}{x_u} \quad 3.8$$

$$\text{or} \quad \frac{x_u}{d - x_u} = \frac{0.0035}{\epsilon_s}$$

$$\text{or} \quad \frac{x_u}{d} = \frac{0.0035}{\epsilon_s + 0.0035}$$

To avoid compression failure, IS 456 recommends minimum strain corresponding 0.0035 strain in steel as

$$\epsilon_{s \min} = 0.87 \frac{f_y}{E} + 0.002$$

\therefore Limiting value of x_u is given by the expression

$$\frac{x_u; \text{lim}}{d} = \frac{0.0035}{0.87 \frac{f_y}{E_s} + 0.002 + 0.0035} = \frac{0.0035}{0.87 \frac{f_y}{E_s} + 0.0055} \quad 3.9$$

Since $E = 2 \times 10^5 \text{ N/mm}^2$ for all types of steels,

$\frac{x_{u \text{ lim}}}{d}$ values for various types of steel are as shown in table 3.1

Table 3.1 Limiting values of Depth of Neutral Axis

Type of steel	F_y in N/mm^2	$\frac{x_{u \text{ lim}}}{d}$
Mild steel (Fe 250)	250	0.53
Fe 415	415	0.48
Fe 500	500	0.46

Depth of Neutral Axis for Under Reinforced Sections

For under reinforced sections, strain in steel is greater than its limiting value ($\epsilon_s > \epsilon_{s \text{ lim}}$). Hence from idealized stress strain curve (Fig. 2.4), we get $f_s = 0.87 f_y$. Substituting it in equation 3.7, we get,

$$\therefore \frac{x_u}{d} = \frac{0.87 f_y A_{st}}{0.36 f_{ck} b d} \quad 3.10$$

DEPTH OF NEUTRAL AXIS FOR OVER REINFORCED SECTIONS

For over reinforced sections, $\epsilon_s < \epsilon_{s \text{ lim}}$. Hence the actual strain in steel at failure ϵ_s is to be found from the equation 3.8. Then using stress strain diagram for steel, corresponding stress is to be found. Since ϵ_s and x_u are interdependent, it is not possible to get one value from the other. Trial and error method is to be used. This is illustrated in Ex 3.4. However a designer has to note that such sections are not to be designed. If already such sections exist, we need this procedure to find depth of neutral axis.

3.6 STRENGTH OF RECTANGULAR SECTIONS IN FLEXURE

The flexural strength of R.C. Section is also known as moment carrying capacity of the section. The compressive force C in concrete and tensile force T in steel are equal and opposite and are separated by distance $d - 0.42x_u$ (ref. Fig. 3.5), which is called as lever arm LA. Hence they form a couple. The couple moment is the moment of resistance and it is called moment carrying capacity when $\epsilon_c = 0.0035$. Thus moment carrying capacity is given by

$$\begin{aligned} M_u &= C \times \text{Lever Arm} \\ &= 0.36 f_{ck} b x_u (d - 0.42x_u) \\ &= 0.36 f_{ck} \frac{x_u}{d} \left(1 - 0.42 \frac{x_u}{d} \right) b d^2 \end{aligned} \quad 3.11$$

M_u may be called as strength of section in flexure. For the limiting case of balanced section,

$$M_{u \text{ lim}} = 0.36 f_{ck} \frac{x_{u \text{ lim}}}{d} \left(1 - 0.42 \frac{x_{u \text{ lim}}}{d}\right) b d^2 \quad 3.12$$

$$= k f_{ck} b d^2$$

where $k = 0.36 \frac{x_{u \text{ lim}}}{d} \left(1 - 0.42 \frac{x_{u \text{ lim}}}{d}\right)$. Substituting the values of $\frac{x_{u \text{ lim}}}{d}$ for different grades of steel (Table 3.1), we get the values of k for finding $M_{u \text{ lim}}$ for different grade of steel as shown in Table 3.2

Table 3.2 Limiting Moment Carrying Capacity for Different Grade of Steels

Type of steel	$\frac{x_{u \text{ lim}}}{d}$	$M_{u \text{ lim}}$
Fe 250 (Mild steel)	0.53	$0.148 f_{ck} b d^2$
Fe 415	0.48	$0.138 f_{ck} b d^2$
Fe 500	0.46	$0.133 f_{ck} b d^2$

Approximate expression for moment of resistance :

In case of under reinforced or balanced sections, where $x_u \leq x_{u \text{ lim}}$, the stress in steel reaches the limiting value of $0.87 f_y$, earlier. Hence the equilibrium equation for horizontal forces gives,

$$C = T$$

$$0.36 f_{ck} b x_u = 0.87 f_y A_{st}$$

or

$$x_u = \frac{0.87 f_y A_{st}}{0.36 f_{ck} b}$$

Moment equilibrium equation gives,

$$M_u = T \times LA = 0.87 f_y A_{st} (d - 0.42 x_u)$$

$$= 0.87 f_y A_{st} \left[d - 0.42 \times \frac{0.87 f_y A_{st}}{0.36 f_{ck} b} \right]$$

$$= 0.87 f_y A_{st} d \left[1 - 1.015 \frac{A_{st} f_y}{bd f_{ck}} \right]$$

IS 456 - 2000, permits the approximation of the above expression as

$$M_u = 0.87 f_y A_{st} d \left[1 - \frac{A_{st} f_y}{bd f_{ck}} \right]$$

In case of over reinforced sections ($x_u > x_{u \text{ lim}}$), the actual moment of resistance of the section may be obtained by usual formula $C \times LA$ or $T \times LA$. However to avoid compression failure, the strength of such sections is to be considered as that of balanced sections only i.e.,

$$M_u = M_{u \text{ lim}} = 0.36 f_{ck} b x_{u \text{ lim}} (d - 0.42 x_{u \text{ lim}})$$

Example 3.1. A singly reinforced beam 250 mm × 500 mm in section is reinforced with 4 bars of 16 mm diameter with an effective cover of 50 mm. Effective span of the beam is 6 m. Assuming M20 concrete and Fe 250 steel, determine the central concentrated load P that can be carried by the beam in addition to its self weight.

Solution.

This beam is shown in Fig. 3.6. In this case,

$$D = 500 \text{ mm}$$

$$\text{Effective cover} = 50 \text{ mm}$$

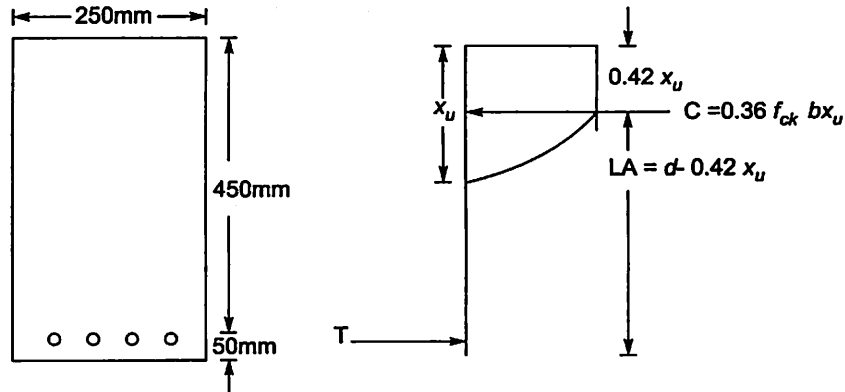

Fig. 3.6

$$\therefore \text{Effective depth } d = 500 - 50 = 450 \text{ mm}$$

$$\text{width of beam} = 250 \text{ mm}$$

$$f_{ck} = 200 \text{ N/mm}^2 \text{ and } f_y = 250 \text{ N/mm}^2$$

$$\text{Area of tensile steel } Ast = 4 \times \frac{\pi}{4} \times 16^2 = 804 \text{ mm}^2$$

(This may be taken from table 95 of sp-16 also).

Assuming that the section is under reinforced/balanced section, equating compression force to tensile force we get,

$$0.36 f_{ck} b x_u = 0.87 f_y Ast$$

$$0.36 \times 20 \times 250 x_u = 0.87 \times 250 \times 804$$

$$\therefore x_u = 97.15 \text{ mm}$$

$$\text{or } \frac{x_u}{d} = \frac{97.15}{450} = 0.216$$

But $\frac{x_{u \text{ lim}}}{d}$ for mild steel is 0.53

$$\therefore x_u < x_{u \text{ lim}}$$

Hence it is under reinforced section and

$$x_u = 97.15 \text{ mm is correct value}$$

$$\therefore M_u = C \times LA$$

$$= 0.36 f_{ck} b x_u (d - 0.42 x_u)$$

$$= 0.36 \times 20 \times 250 \times 97.15 (450 - 0.42 \times 97.15)$$

$$= 71.81 \times 10^6 \text{ Nmm}$$

$$= 71.81 \text{ kN m.}$$

The loads acting on the beam are as shown in Fig. 3.7

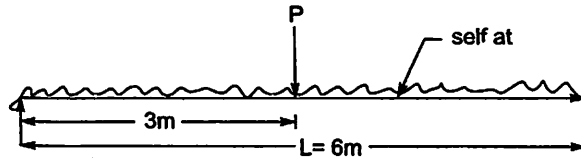

Fig. 3.7

Let P be concentrated load in kN at centre and w be the self weight in kN per metre length

$$\therefore w = 0.25 \times 500 \times 25 = 3.125 \text{ kN/m}$$

$$\therefore \text{Design self weight } w_u = 1.5w = 1.5 \times 3.125 = 4.6875 \text{ kN/m}$$

$$\text{Design concentrated load } P_u = 1.5 P$$

$$\therefore \text{Design moment } M_u = w_u \frac{L^2}{8} + \frac{P_u L}{4}$$

$$M_u = 4.6875 \times \frac{6^2}{8} + 1.5 P \frac{6}{4}$$

$$= 21.093 + 2.25 P$$

Equating it to moment of resistance of the section, we get

$$21.093 + 2.25P = 71.81$$

$$\therefore P = 22.540 \text{ kN/m}$$

Ans.

Example 3.2. A R.C.C. beam of section $300 \text{ mm} \times 500 \text{ mm}$ is reinforced with 4 bars of 16 mm diameter with an effective cover of 50 mm . The beam is simply supported over a span of 5 m . Find the maximum permissible udl on the beam. Use M20 grade of concrete and Fe 500 steel.

Solution.

$$b = 300 \text{ mm, } d = 500 \text{ mm} \quad \text{Cover} = 50 \text{ mm}$$

$$d = 500 - 50 = 450 \text{ mm}$$

$$A_{st} = 4 \times \frac{\pi}{4} \times 16^2 = 804 \text{ mm}^2$$

$$f_{ck} = 20 \text{ N/mm}^2$$

$$f_y = 500 \text{ N/mm}^2$$

Assuming the section to be under reinforced/balanced and then equating compressive force to tensile force, we get

$$0.36 f_{ck} b x_u = 0.87 f_y A_{st}$$

$$0.36 \times 20 \times 300 x_u = 0.87 \times 500 \times 804$$

\therefore

$$x_u = 161.92 \text{ mm}$$

$$x_{u \text{ lim}} = 0.46d = 0.46 \times 450 = 207 \text{ mm}$$

$\therefore x_u < x_{u \text{ lim}}$. Hence the assumption that it is under reinforced section is correct and $x_u = 161.92$ can be used.

$$M_u = C \times LA$$

$$= 0.36 \times 20 \times 300 \times 161.92 (450 - 0.42 \times 161.92)$$

$$= 133.60 \times 10^6 \text{ Nm}$$

$$= 133.60 \text{ kN/m}$$

Let the total designed udl be w_u kN/m length.

Then M_u required

$$= \frac{w_u L^2}{8} = w_u \frac{5^2}{8} = \frac{25}{8} w_u$$

Equating it to M_u of the section, we get

$$\frac{25}{8} w_u = 133.60$$

$$\therefore w_u = 42.752 \text{ kN/m}$$

$$\therefore \text{Total } w = \frac{w_u}{1.5} = \frac{42.752}{1.5} = 28.501 \text{ kN/m}$$

$$\text{self } wt = 0.3 \times 0.5 \times 25 = 3.75 \text{ kN/m}$$

\therefore Superimposed load the beam can carry

$$= 28.501 - 3.75 = 24.751 \text{ kN/m}$$

Ans.

Example 3.3. A rectangular section of effective size 300 mm \times 500mm is used as a simply supported beam for effective span 7m. What maximum udl can be allowed on the beam, if the maximum percentage of steel is provided, only on tension side? Use M20 concrete and Fe 415 steel. Determine the amount of steel to be provided.

Solution.

$$b = 300 \text{ mm,}$$

$$f_{ck} = 20 \text{ N/mm}^2$$

$$d = 500 \text{ mm}$$

$$f_y = 415 \text{ N/mm}^2$$

The maximum amount of steel permitted is provided means it is designed as a balanced section.

$$\therefore \frac{x_u}{d} = \frac{x_{u \text{ lim}}}{d} = 0.48$$

$$\therefore x_{u \text{ lim}} = 0.48 \times d$$

$$\therefore M_u = M_{u \text{ lim}} = 0.36 f_{ck} b x_{u \text{ lim}} (d - 0.42 x_{u \text{ lim}})$$

$$= 0.36 \times 20 \times 300 \times 0.48 \times 500 (500 - 0.42 \times 500)$$

$$= 207 \times 10^6 \text{ N mm}$$

$$(\text{or } M_{u \text{ lim}} = 0.138 f_{ck} b d^2 = 207 \times 10^6 \text{ N-mm})$$

Thus

$$M_u = 207 \text{ kN-m}$$

Let w_u be the designed load in kN per meter length. Then Maximum moment

$$= \frac{w_u L^2}{8} = w_u \times \frac{7^2}{8} = \frac{49}{8} w_u \text{ kN/m}$$

Equating it to the moment carrying capacity of the balance section $M_{u \text{ lim}}$, we get,

$$\frac{49}{8} w_u = 206.945$$

$$w_u = 33.787 \text{ kN/m}$$

\therefore Total load carrying capacity in working condition is

$$w = \frac{w_u}{1.5} = 22.525 \text{ kN/m}$$

34 Design of R.C.C. Structural Elements

Self $= 0.3 \times 0.55 \times 25 = 4.125 \text{ kN/m}$
 (assuming 50mm cover)

\therefore Superimposed maximum udl on the beam
 $= 22.525 - 4.125$
 $= 18.40 \text{ kN/m}$

Ans.

Amount of steel for balanced section can be obtained by equating compressive force to tensile force as $0.36 f_{ck} b x_{u \text{ lim}} = 0.87 f_y A_{st}$

i.e., $0.36 \times 20 \times 300 \times 0.48 \times 500 = 0.87 \times 415 \times A_{st}$

$A_{st} = 1435.81 \text{ mm}^2$

Ans.

Example 3.4. A rectangular beam 250 mm wide and effective depth 500 mm has 4 bars of 22mm diameter. Find the position of the neutral axis, the lever arm, the forces of compression and tension and the actual moment of resistance, if concrete is M20 mix and steel is Fe 415 grade. As per IS 456-2000, to what value it is to be limited?

Solution.

$b = 250 \text{ mm}$ $d = 500 \text{ mm}$

$A_{st} = 4 \times \frac{\pi}{4} \times 22^2 = 1520.53 \text{ mm}^2$

$f_{ck} = 20 \text{ N/mm}^2$ $f_y = 415 \text{ N/mm}^2$ $L = 6 \text{ m}$

Assuming that it is under reinforced or balanced section,

$C = T$ gives

$0.36 f_{ck} b x_u = 0.87 f_y A_{st}$

$0.36 \times 20 \times 250 \times x_u = 0.87 \times 415 \times 1520.53$

$x_u = 304.99 \text{ mm}$

But

$x_{u \text{ lim}} = 0.48d = 0.48 \times 500 = 240 \text{ mm}$

\therefore

$x_u > x_{u \text{ lim}}$

i.e., it is a over reinforced section and hence the assumption of under reinforced or balance section ($\epsilon_s \leq \epsilon_{su}$) is wrong. ' ϵ_s ' the strain in steel when strain in concrete ϵ_{su} is reached is less than $\epsilon_{s \text{ lim}}$. x_u must be between 240 mm and 304.99. It is to be found by trial and error method, From strain diagram (Fig. 3.8),

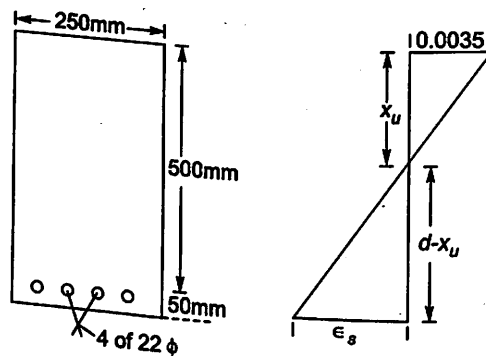

Fig. 3.8

$$\frac{\varepsilon_s}{d - x_u} = \frac{0.0035}{x_u}$$

$$\therefore \varepsilon_s = (d - x_u) \frac{0.0035}{x_u}$$

Assuming $x_u = 275$ mm, we get

$$\begin{aligned} \therefore \varepsilon_s &= (500 - 275) \frac{0.0035}{275} \\ &= 2.8636 \times 10^{-3} \end{aligned}$$

From stress strain diagram, corresponding stress in steel $f_s = 0.82 f_y$

Equating total compression to tensile force, we get

$$0.36 f_{ck} b x_u = f_s A_{st}$$

$$0.36 \times 20 \times 250 \times x_u = 0.82 \times 415 \times 1520.53$$

$$x_u = 287.46$$

But assumed x_u was 275 mm

\therefore Actual x_u should be between 275 mm and 287.46 mm

Now taking trial value of $x_u = 282.2$ mm

$$\begin{aligned} \text{Then } \varepsilon_s &= (d - x_u) \frac{0.0035}{x_u} \\ &= (500 - 282.2) \frac{0.0035}{282.2} = 2.698 \times 10^{-3} \end{aligned}$$

Corresponding stress in steel $\left(\text{from the graph corresponding } \frac{f_y}{1.115} \right)$

We get $f_s = 0.808$ $f_y = 335.32$ N/mm². Equating compressive force to tensile force we get,

$$0.36 \times 20 \times 250 x_u = 335.32 \times 1520.53$$

$$x_u = 283.2 \text{ mm}$$

$$\text{Let us take } M_u = \frac{282.2 + 283.2}{2} = 282.7 \text{ mm}$$

$$\text{Then lever arm } LA = d - 0.42x_u$$

$$= 500 - 0.42 \times 282.7$$

$$= 381.27$$

$$T = C = 0.36 f_{ck} b x_u = 0.36 \times 20 \times 250 \times 282.7 = 508860 \text{ N}$$

$$M = C \times LA$$

$$= 508860 \times 381.27$$

$$= 194.011 \times 10^6 \text{ Nmm}$$

$$= 194.011 \text{ kNm}$$

However since compression failures are to be avoided, its value is to be limited to $M_{u \text{ lim}}$

$$M_u = M_{u \text{ lim}} = 0.36 f_{ck} b x_{u \text{ lim}} (d - 0.42 x_{u \text{ lim}})$$

$$= 0.36 \times 20 \times 250 \times 0.48 \times 500 (500 - 0.42 \times 0.48 \times 500)$$

$$= 172.454 \times 10^6 \text{ Nmm}$$

$$= 172.454 \text{ kNm}$$

Ans.

3.7 FLANGED SECTION IN FLEXURE

T beams and L beams are the common examples of flanged beams. Typical T and L beams are shown in Fig. 3.9.

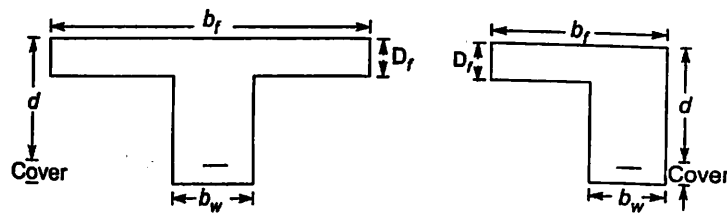

Fig. 3.9 Typical T and L Beams.

- b_w – width of web
- b_f – width of flange
- d – effective depth of beam
- D_f – depth of flange

Actually T and L beams are rarely cast specially to have those shapes; but when slab and beam are cast monolithically, at portion where slab is on compression side, beam behaves as flanged beam. Fig. 3.10 shows a typical floor plan which is cast monolithically with the beams.

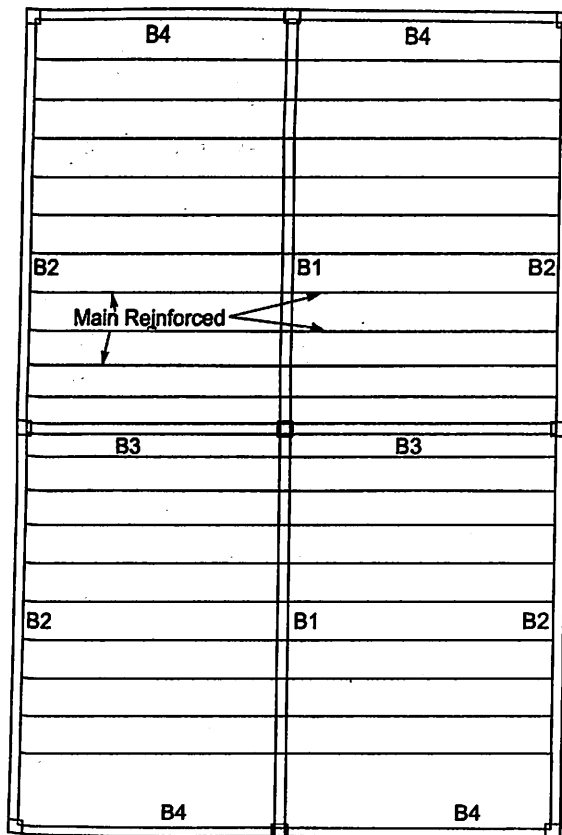

Fig. 3.10 A typical floor plan in which Beam and Slabs are cast monolithically

When beam B1 bends due to dead and imposed loads, in the middle portion bending moment is sagging moment. Hence slab is on compression side. Some portion of slab contributes to the compression resistance of the beam. Hence section at mid span of beam B1 may be taken as T beam. Similarly at mid span of section of B2 may be treated as L beam. For these beams reinforcement in the slab is transverse to beam cross section.

In case of mid span sections of B3 and B4 the reinforcements in the slab are parallel to the beam. These sections can be treated as flanged sections, only when the following requirements are met:

- (a) The slab shall be cast integrally with the web or the web shall be effectively bonded together in any other manner, and
- (b) The transverse reinforcement shall be provided. Such reinforcement shall not be less than 60% of the main reinforcement at mid span of the slab.

Effective width of Flange (As per IS 456, Clause 23.1.2)

In the absence of more accurate determinations, the effective width of flange may be taken as the following but in no case greater than the breadth of web plus half the sum of the clear distances to the adjacent beams on either side

- (a) For T beams

$$b_f = \frac{l_0}{6} + b_w + 6D_f \quad 3.14$$

- (b) For L beams

$$b_f = \frac{l_0}{12} + b_w + 3D_f \quad 3.15$$

- (c) For isolated beams, the effective flange width shall be obtained as given below but in no case greater than the actual width

T-beam,

$$b_f = \frac{l_0}{\frac{l_0}{b} + 4} + b_w \quad 3.16$$

L-beam,

$$b_f = \frac{0.5l_0}{\frac{l_0}{b} + 4} + b_w \quad 3.17$$

where

l_0 = distance between points of zero moments in the beam

Note: For continuous beams and frames l_0 may be assumed as 0.7 times the effective span

3.8 STRENGTH OF FLANGED SECTIONS IN FLEXURE

Moment resisting capacity of the flanged sections depends upon the depth of neutral axis. Based on the value of depth of neutral axis x_u , the following three cases arise.

- (a) If $x_u \leq D_f$, compressive force is in the flange only.
- (b) If $\frac{3}{7}x_u > D_f$, compressive stress in the flange is uniform, and
- (c) If $x_u > D_f$ and $\frac{3}{7}x_u < D_f$, compressive stress in flange is non uniform

These situations are shown in Fig 3.11

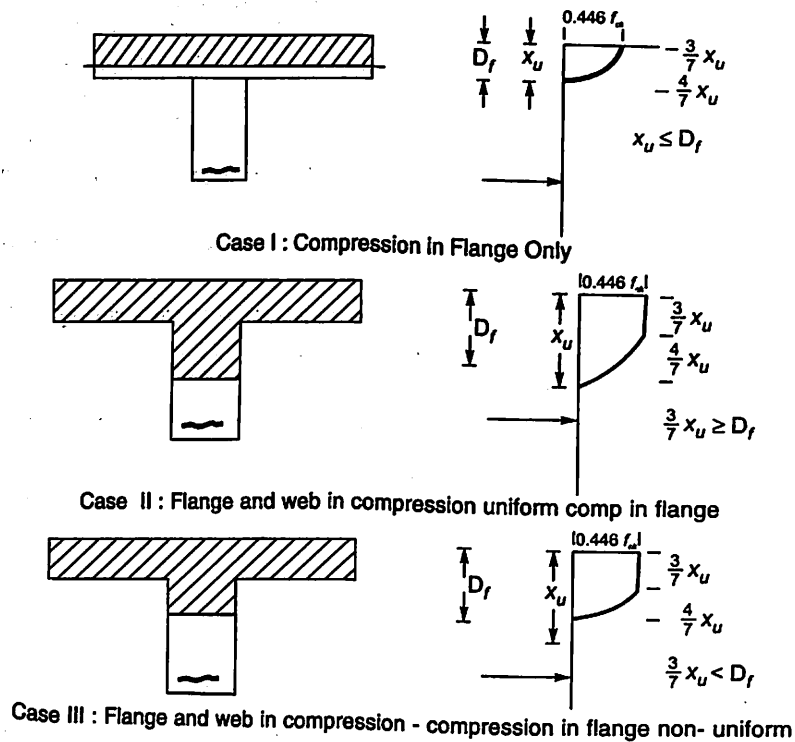

Fig. 3.11

Moment of Resistance in Case I: $x_u < D_f$

In this case neutral axis lies within the flange

$$C = 0.36 f_{ck} b_f x_u$$

$$T = 0.87 f_y A_{st}$$

$$C = T \text{ gives}$$

$$x_u = \frac{0.87 f_y A_{st}}{0.36 f_{ck} b_f}$$

∴

$$M_u = C \times LA$$

$$= 0.36 f_{ck} b_f x_u (d - 0.42x_u)$$

3.18

Thus the expressions are same as for rectangular section, but of width b_f .

Moment of resistance in Case II: $\frac{3}{7} x_u > D_f$

However x_u should not exceed $x_{u \text{ lim}}$. Thus this case is applicable for

$$\frac{3}{7} x_{u \text{ lim}} \geq D_f$$

or

$$D_f \leq \frac{3}{7} x_{u \text{ lim}}$$

$$\frac{D_f}{d} \leq \frac{3}{7} \frac{x_{u \text{ lim}}}{d}$$

For various steel this case is upto the value indicated below in table 3.3

Table 3.3 Limiting value of $\frac{D_f}{d}$ upto which Case II is applicable

Type of steel	$\frac{x_{u \text{ lim}}}{d}$	$\frac{D_f}{d}$
Fe 250	0.53	0.2271
Fe 415	0.48	0.2057
Fe 500	0.46	0.1971

IS 456 code generalizes these cases and says, if $\frac{D_f}{d} \leq 0.2$ treat it as Case II.

For finding moment of resistance of the section in these cases, the compressive portion of the concrete is divided into two parts (Ref. Fig. 3.12)

- The web of width b_w and depth x_u
- Projected flange of width $b_f - b_w$ and depth D_f

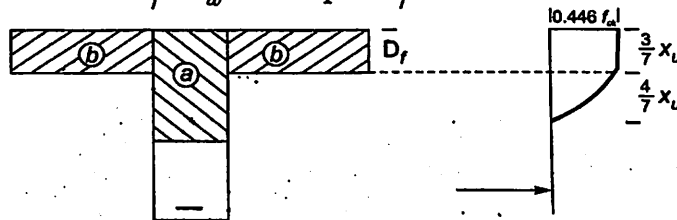

Fig 3.12

Compressive force in web

$$C_w = 0.36 f_{ck} b_w x_u$$

Compressive force in flange

$$C_f = (b_f - b_w) 0.446 f_{ck} D_f$$

As only under reinforced/balanced sections are accepted, steel has reached its limiting stress

$$T = 0.87 f_y A_{st}$$

Equating compressive force to tensile force,

We get

$$0.36 f_{ck} b_w x_u + (b_f - b_w) 0.446 f_{ck} D_f = 0.87 f_y A_{st} \quad 3.19$$

From the above equation depth of neutral axis x_u can be obtained.

$$\begin{aligned} \therefore M_u &= M_{uw} + M_{uf} \\ &= 0.36 f_{ck} b_w x_u (d - 0.42 x_u) + 0.446 f_{ck} (b_f - b_w) D_f \left(d - \frac{D_f}{2} \right) \quad 3.20 \end{aligned}$$

Area of steel A_{st} required can be found by equating total compression to total tension

$$C = T$$

$$i.e., \quad C_w + C_f = T$$

Case III $\frac{3}{7} x_u < D_f$ (or $\frac{D_f}{d} < 0.2$) and $x_u > D_f$

Compressive force in web portion

$$C_w = 0.36 f_{ck} b x_u$$

and acts at $0.42x_u$ from maximum compressive fibre

Compressive force in the projection of flange:

For a depth of $\frac{3}{7} x_u$ compression is uniform and its value is $0.446 f_{ck}$. The distribution of

compressive stress over the remaining depth of flange $D_f - \frac{3}{7} x_u$ is parabolic. Finding the force over this portion involves lengthy calculations. In order to simplify the calculations IS 456-2000 recommends the concept of modified thickness of flange equal to y_f . The average compressive stress over this depth y_f is assumed to be uniform of intensity $0.446 f_{ck} \approx 0.45 f_{ck}$, where

$$y_f = 0.15x_u + 0.65 D_f \tag{3.22}$$

The modified depth of flange, y_f should not be more than the actual depth of flange D_f . If y_f comes out to be more than D_f , obviously case II will be applicable.

∴

$$C_f = \text{Average stress} \times \text{Area of flange projection}$$

$$= 0.45 f_{ck} y_f (b_f - b_w)$$

Since only under reinforced or balanced sections are to be used, stress in steel has reached its limiting value. Hence

$$T = 0.87 f_y A_{st}$$

The condition

$$C = T, \text{ gives}$$

$$0.36 f_{ck} b_w x_u + 0.45 f_{ck} y_f (b_f - b_w) = 0.87 f_y A_{st} \tag{3.23}$$

From this x_u may be determined. Then

$$M_u = C_w (d - 0.42x_u) + C_f (d - 0.5y_f) \\ = 0.36 f_{ck} b_w x_u (d - 0.42x_u) + 0.45 f_{ck} y_f (b_f - b_w) (d - 0.5y_f) \tag{3.24}$$

Limiting value of moment of resistance of flanged section is when $X_u = x_{u \text{ lim}}$

$$\therefore M_{u \text{ lim}} = 0.36 f_{ck} b_w x_{u \text{ lim}} (1 - 0.42x_{u \text{ lim}}) + 0.45 f_{ck} y_f (b_f - b_w) (d - 0.5y_f) \tag{3.25}$$

where

$$y_f = 0.15 x_{u \text{ lim}} + 0.65 D_f \text{ but not more than } D_f$$

Example 3.5. A T beam R.C. floor system consists of 120 mm thick slab supported by beams at 3m centre to centre. The effective width and depth of web is 300 mm × 580 mm as shown in Fig. 3.13. Main reinforcement consists of 8 bars of 20 mm diameter. The grade of concrete and steel used are M20 and Fe 415 respectively. Determine the moment of resistance of the T beam, if it is used as simply supported beam of span 3.6 m.

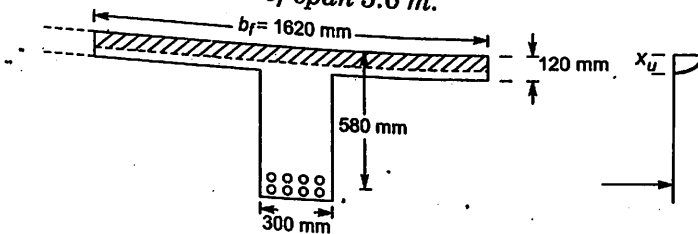

Fig. 3.13

Solution

In this problem,

$$D_f = 120 \text{ mm}, b_w = 300 \text{ mm}, d = 580 \text{ mm}$$

$$A_{st} = 8 \times \frac{\pi}{4} \times 20^2 = 2513 \text{ mm}^2$$

Span $L = 3.6 \text{ m}$. Since it is used as simply supported beam, the distance between the points of zero moments $l_0 = 3.6 \text{ m}$

\therefore Effective width of flange

$$b_f = \frac{l_0}{6} + b_w + 6D_f = \frac{3600}{6} + 300 + 6 \times 120 = 1620 \text{ mm}$$

In this problem, clear span of the slab to the left and right of the beam are

$$L_1 = L_2 = 3000 - 300 = 2700 \text{ mm}$$

$$\therefore b_f > 0.5(L_1 + L_2) + b_w \\ > 0.5(2700 + 2700) + 300$$

$$\text{i.e.} \quad > 3000 \text{ mm}$$

Hence $b_f = 1620 \text{ mm}$ is OK

Assuming x_u is within the flange,

$$C = T \text{ gives}$$

$$0.36 f_{ck} b_f x_u = 0.87 f_y A_{st}$$

$$0.36 \times 20 \times 1620 x_u = 0.87 \times 415 \times 2513$$

$$x_u = 77.79 \text{ mm} < D_f$$

Assumption is correct

$$x_{u \text{ lim}} = 0.48 d = 0.48 \times 580 = 278.4 \text{ mm}$$

Thus $x_u < x_{u \text{ lim}}$

Therefore it is under reinforced section.

$$\text{Lever arm} \quad LA = d - 0.42 x_u \\ = 580 - 0.42 \times 77.79 \\ = 547.33 \text{ mm}$$

$$\therefore M_u = 0.36 f_{ck} b_f x_u LA \\ = 0.36 \times 20 \times 1620 \times 77.79 \times 547.33 \\ = 496.61 \times 10^6 \text{ Nmm}$$

Thus $M_u = 496.61 \text{ kN m}$

Ans.

Example 3.6. An isolated T beam has flange of 2400 mm wide and 120 mm deep. The effective width and depth of web are 300 mm and 580 mm respectively. The tension reinforcement consists of eight bars of 20 mm diameter. The effective span of the simply supported T-beam is 3.6 m. Determine the moment of resistance of the beam. The grade of concrete and steel are M20 and Fe 415 respectively.

Solution.

The cross section details of the T beam are shown in Fig 3.14. In this case,

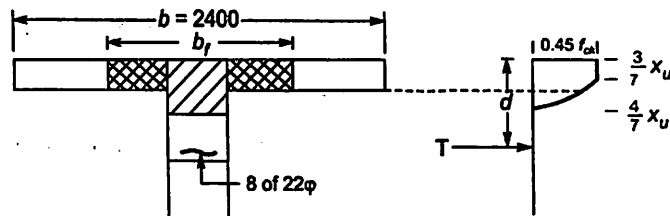

Fig. 3.14

Actual width of isolated T beam = 2400 mm

$$D_f = 120 \text{ mm}, b_w = 300 \text{ mm} \text{ and } d = 580 \text{ mm}$$

$$A_{st} = 8 \times \frac{\pi}{4} \times 22^2 = 3041 \text{ mm}^2$$

$$f_{ck} = 20 \text{ N/mm}^2 \quad f_y = 415 \text{ N/mm}^2$$

Since it is simply supported beam

$$l_0 = L = 3.6 \text{ m} = 3600 \text{ mm}$$

∴ Effective width of flange

$$= \frac{l_0}{\frac{l_0}{b} + 4} + b_w$$

$$= \frac{3600}{\frac{3600}{2400} + 4} + 300 = 954.55 \text{ mm} < b, \text{ actual}$$

∴

$$b_f = 954.55 \text{ mm}$$

Depth of NA (x_u)

Assuming neutral axis is within the flange,

$$C = T, \text{ gives}$$

$$0.36 f_{ck} b_f x_u = 0.87 f_y A_{st}$$

$$0.36 \times 20 \times 954.55 x_u = 0.87 \times 415 \times 3041$$

∴

$$x_u = 159.76 > D_f$$

Hence assumption is wrong. NA lies in web. Since the above value is slightly more than D_f ,

it is likely that $\frac{3}{7} x_u < D_f$ (case III). Hence this case may be tried now.

$$C = T \text{ gives,}$$

$$C_w + C_f = T$$

$$\text{i.e., } 0.36 f_{ck} b_w x_u + [0.45 f_{ck} y_f (b_f - b_w)] = 0.87 f_y A_{st}$$

$$0.36 \times 20 \times 300 x_u + 0.45 \times 20 \times y_f (954.55 - 300) = 0.87 \times 415 \times 3041$$

$$\text{i.e., } 2160 x_u + 5890.95 y_f = 1097953$$

$$\begin{aligned} \text{but } y_f &= 0.15 x_u + 0.65 D_f \\ &= 0.15 x_u + 0.65 \times 120 \\ &= 0.15 x_u + 78 \end{aligned}$$

∴ we get,

$$2160 x_u + 5890.95(0.15 x_u + 78) = 1097953$$

$$\text{i.e., } x_u (2160 + 883.64) = 1097953 - 5890.95 \times 78$$

$$\therefore x_u = 209.77 \text{ mm}$$

$$\therefore \frac{3}{7} x_u = 89.90 < 120 \text{ mm (i.e. } D_f)$$

∴ The assumption is OK. x_u can be taken as 209.77 mm

$$\text{Now } x_{u \text{ lim}} = 0.48d = 0.48 \times 580 = 278.4 \text{ mm}$$

Hence the section is under reinforced.

∴ Moment of resistance of the section

$$\begin{aligned} M_u &= C_w (d - 0.42 x_u) + C_f (d - \frac{y_f}{2}) \\ &= 0.36 f_{ck} b_w x_u (d - 0.42 x_u) + 0.45 f_{ck} y_f (b_f - b_w) (d - 0.5 y_f) \\ &= 0.36 \times 20 \times 300 \times 209.77 (580 - 0.42 \times 209.77) \\ &\quad + 0.45 \times 20 \times 109.47 (954.55 - 300) (580 - 0.5 \times 109.47) \\ &= 561.614 \times 10^6 \text{ Nmm} \end{aligned}$$

$$M_u = 561.614 \text{ kN m}$$

Ans.

Example 3.7. What will be the moment of resistance of the section if the tensile steel in the example 3.6 is replaced by 10 numbers of 25 mm diameter bars?

Solution.

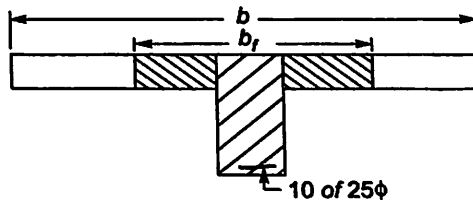
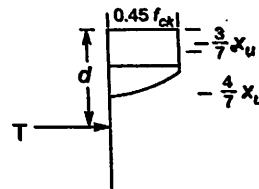

Fig. 3.15



In this problem, also

$$b_f = 954.55 \text{ mm} \quad D_f = 120 \text{ mm} \quad d = 580 \text{ mm} \quad b_w = 300 \text{ mm}$$

$$\text{But, } A_{st} = 10 \times \frac{\pi}{4} \times 25^2 = 4908 \text{ mm}^2$$

Assuming x_u is within flange ($x_u < d_f$)

$$C = T, \text{ gives}$$

$$0.36 f_{ck} b_f x_u = 0.87 f_y A_{st}$$

$$0.36 \times 20 \times 954.55 x_u = 0.87 \times 415 \times 4908$$

$$\therefore x_u = 257.83 \text{ mm} > D_f$$

∴ Assumption is wrong since x_u calculated is much more than D_f . Let us try the case in which $\frac{3}{7}x_u > D_f$ (case II)

Equilibrium equation $C = T$, gives

$$C_w + C_f = T$$

$$0.36 f_{ck} b_w x_u + 0.446 f_{ck} (b_f - b_w) D_f = 0.87 f_y A_{st}$$

$$0.36 \times 20 \times 300 x_u + 0.446 \times 20 (954.55 - 300) \times 120 = 0.87 \times 415 \times 4908$$

i.e., $2160 x_u + 700630 = 1772033$

∴ $x_u = 496.02 \text{ mm}$

∴ $\frac{3}{7} x_u = 212.58 > D_f$

∴ Assumption is correct. Hence

$$x_u = 496.02 \text{ mm}$$

Now

$$x_{u \text{ lim}} = 0.48 \times 580 = 278.4 \text{ mm}$$

Thus

$$x_u > x_{u \text{ lim}}$$

Hence over reinforced section

i.e.,

$$f_s < f_y$$

where stress in steel is f_s and is to be found from stress strain curve. Linear relation of strain in concrete and steel gives

$$\frac{\epsilon_s}{d - x_u} = \frac{0.0035}{x_u}$$

or

$$\epsilon_s = 0.0035 \frac{d - x_u}{x_u}$$

x_u is to be determined by trial and error method. It should be between 278.4 mm (i.e., $x_{u \text{ lim}}$) and 496.14 mm (found from wrong assumption). Let the trial value be 390 mm (Approximately average value)

$$\epsilon_s = 0.0035 \frac{(580 - 390)}{390} = 1.705 \times 10^{-3}$$

From stress strain curve for steel $f_s = 311 \text{ N/mm}^2$. Then equating compressive and tensile forces we get,

$$C = T$$

i.e.,

$$C_f + C_w = T$$

i.e., $0.36 f_{ck} b x_u + 0.446 f_{ck} (b_f - b_w) D_f = f_s A_{st}$

$$0.36 \times 20 \times 300 x_u + 0.446 \times 20 (954.55 - 300) \times 120 = 311 \times 4908$$

∴

$$x_u = 382.3 < \text{Assumed value of } 390 \text{ mm.}$$

Since the values are quite close, let us take actual x_u as approximately the average of the two.

Thus

$$x_u = 386 \text{ mm is take as the actual value. Then,}$$

$$\begin{aligned}
 M_u &= 0.36 f_{ck} b_w x_u (d - 0.42 x_u) + 0.446 f_{ck} \\
 &\quad (b_f - b_w) D_f (d - 0.5 D_f) \\
 &= 0.36 \times 20 \times 300 \times 386 (580 - 0.42 \times 386) \\
 &\quad + 0.446 \times 20 (954.55 - 300) \times 120 (580 - 0.5 \times 120) \\
 &= 712.739 \times 10^6 \text{ N mm} \\
 M_u &= 712.739 \text{ kN m}
 \end{aligned}$$

Ans.

3.9 STRENGTH OF DOUBLY REINFORCED SECTIONS IN FLEXURE

R.C. beams provided with steel reinforcements on both tensile and compression side are called doubly reinforced beams. The situations in which the doubly reinforced sections to be used are listed below:

- From architectural or any other construction problems, the depth of R.C. beam is to be restricted.
- In some cases bending moment at the section changes the sign due to variation in loading
Some of the examples of such situations are,
 - Due to moving loads in continuous beams
 - In precast members during handling
 - In bracing members of frames due to changes in the direction of wind loads.
- To improve the ductility of beams in earthquake regions
- To reduce long term deflections.

Fig. 3.16 shows a typical R.C. beam of doubly reinforced section along with strain and stress variation along the depth.

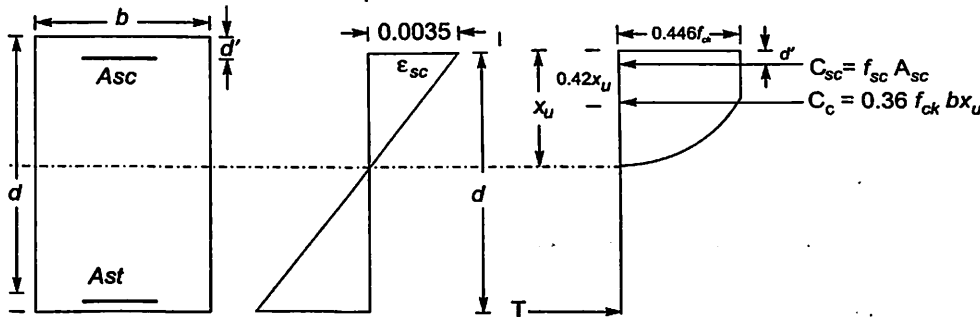

Fig. 3.16

The compressive steel of area A_{sc} is provided at an effective cover d' from extreme compression fibre. Let the stress in this steel be f_{sc} . Then total compressive force is given by

$$C = C_c + C_s \quad 3.26$$

Where C_c is compressive force in concrete and C_s is the compressive force in compressive steel.

$$C_c = 0.36 f_{ck} b x_u - f_{cc} A_{sc}$$

Where f_{cc} is the compressive stress in concrete at the level of compressive steel and the term $f_{cc} A_{sc}$ represents the reduction of compressive force due to removal of concrete for

placing compressive steel. Compared to other terms in assembling the compressive forces, this term is negligibly small. Hence this term is neglected. Thus

$$C_c = 0.36 f_{ck} b x_u$$

Now,

$$C_c = f_{sc} Asc$$

And

$$T = 0.87 f_y Ast,$$

since in the design tensile steels yielded condition only is considered. In case steel has not yielded (over reinforced section), it can be found as shown in the analysis of over reinforced section. By equating compressive and tensile forces to get equilibrium, we have

$$C = T$$

$$0.36 f_{ck} b x_u + f_{sc} Asc = 0.87 f_y Ast$$

3.27

From the above equation x_u can be found. To find the stress in compression steel the following procedure may be followed.

From the strain diagram at failure, the strain at the level of compression steel

$$\epsilon_{sc} = 0.0035 \frac{x_u - d'}{x_u} = 0.0035 \left(1 - \frac{d'}{x_u} \right)$$

3.28

The corresponding stress in compression steel may be obtained from stress strain curve of steel. SP-16 gives the following table for Fe 415 and Fe 500 steel as extract of their stress strain curves.

Table 3.4 Salient Points on the Design Stress Strain Curve for Cold Worked Bars [Table A-SP-16]

Stress Level	$f_y = 415 \text{ N/mm}^2$		$f_y = 500 \text{ N/mm}^2$	
	Strain	Stress in N/mm^2	Strain	Stress in N/mm^2
$0.80 f_y$	0.00144	288.7	0.00174	347.8
$0.85 f_y$	0.00163	306.7	0.00194	369.6
$0.90 f_y$	0.00192	324.8	0.00226	391.3
$0.95 f_y$	0.00241	342.8	0.00277	413.0
$0.975 f_y$	0.00276	351.8	0.00312	423.9
$1.0 f_y$	0.00380	360.9	0.00417	434.8

Note: Linear interpolation may be done for intermediate values. Since values x_u and f_{sc} are interdependent, x_u is to be found by trial and error method.

However in case of mild steel direct relation can be established since the idealized stress strain curve is linear upto f_y , and then it is constant f_y . Hence for mild steel

$$f_{sc} = \epsilon_{sc} E_s$$

$$= 0.0035 \left(1 - \frac{d'}{x_u} \right) 2 \times 10^5$$

$$= 700 \left(1 - \frac{d'}{x_u} \right), \text{ subject to maximum of } 0.87 f_y$$

3.24

x_u can be found using equations 3.27 and 3.29. Once x_u is found moment of resistance of the section can be found by multiplying compressive force C_c and C_s by respective lever arms (distances of these forces from tensile force).

$$\begin{aligned} M_u &= C_c (d - 0.42x_u) + C_s (d - d') \\ &= 0.36 f_{ck} b x_u (d - 0.42x_u) + f_{ck} A_{sc} (d - d') \end{aligned} \quad 3.30$$

Example 3.8. Calculate the moment of resistance of a R.C. beam of rectangular section 250 mm wide and 500 mm deep, if it is reinforced with 6 number of 20 mm bars on tension side and 2 number of 20 mm bars on compression side. Assume steel of grade Fe 250 and concrete of grade M20. Effective cover provided is 40 mm on both sides.

Solution.

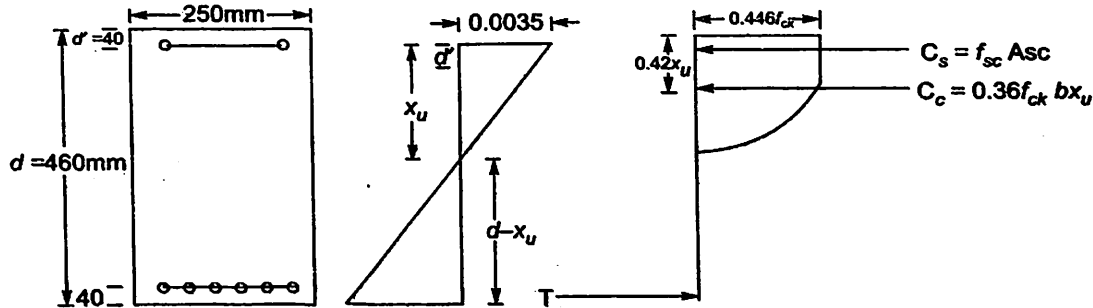

Fig. 3.17

$$\begin{aligned} b &= 250 \text{ mm} & D &= 500 \text{ mm} & \text{Effective Cover} &= 40 \text{ mm on both sides} \\ \therefore d' &= 40 \text{ mm} & d &= 500 - 40 = 460 \text{ mm} \\ f_{ck} &= 20 \text{ N/mm}^2 & f_y &= 250 \text{ N/mm}^2 \end{aligned}$$

$$A_{st} = 6 \times \frac{\pi}{4} \times 20^2 = 1885 \text{ mm}^2$$

$$A_{sc} = 2 \times \frac{\pi}{4} \times 20^2 = 628 \text{ mm}^2$$

Assuming compression as well as tensile steel yielded,

$$C = T \text{ gives}$$

$$0.36 f_{ck} b x_u + 0.87 f_y A_{sc} = 0.87 f_y A_{st}$$

$$\text{i.e., } 0.36 \times 20 \times 250 x_u + 0.87 \times 250 \times 628 = 0.87 \times 250 \times 1885$$

$$\therefore x_u = 151.89 \text{ mm}$$

$$x_{u \text{ lim}} = 0.53, d = 0.53 \times 460 = 243.8$$

$$x_u < x_{u \text{ lim}} \quad \therefore \text{ Tension steel has yielded}$$

Strain in compression steel

$$\begin{aligned} \epsilon_{sc} &= \frac{x_u - d'}{x_u} \epsilon_c = \frac{151.89 - 40}{151.89} \times 0.0035 \\ &= 2.57828 \times 10^{-3} \end{aligned}$$

Minimum strain at which yielding starts in compression steel

$$\epsilon_{s \text{ min}} = 0.87 \frac{f_y}{E_s} = \frac{0.87 \times 250}{2 \times 10^5} = 1.0875 \times 10^{-3}$$

Thus $\epsilon_{sc} > \epsilon_{sy \text{ min}}$. Hence assumption that stress in compression steel is $0.87 f_y$ is correct.

$$\therefore x_u = 151.89 \text{ mm is correct}$$

$$\begin{aligned} \therefore M_u &= 0.36 f_{ck} b x_u (d - 0.42 x_u) + f_{sc} A_{sc} (d - d') \\ &= 0.36 \times 20 \times 250 \times 151.89 (460 - 0.42 \times 151.89) \\ &\quad + 0.87 \times 250 \times 628 (460 - 40) \\ &= 165.69 \times 10^6 \text{ N mm} \end{aligned}$$

$$M_u = 165.69 \text{ kN m}$$

Ans.

Example 3.9. If in the example 3.8 compression steel is replaced by 5 numbers of 20 mm diameter bars, what is the moment of resistance of the section?

Solution.

$$\text{Now } A_{sc} = 5 \times \frac{\pi}{4} \times 20^2 = 1570 \text{ mm}^2$$

Assuming that compression as well as tensile steel have yielded, the equilibrium equation gives,

$$\begin{aligned} 0.36 f_{ck} b x_u + 0.87 f_y A_{sc} &= 0.87 f_y A_{st} \\ \text{i.e., } 0.36 \times 20 \times 250 x_u &= 0.87 \times 250 (A_{st} - A_{sc}) \\ &= 0.87 \times 250 (1885 - 1570) \end{aligned}$$

$$x_u = 38.06 \text{ mm}$$

$$x_{u \text{ lim}} = 0.53, \quad d = 0.53 \times 460 = 243.8 \text{ mm}$$

Assumption that tensile steel has yielded is correct.

Strain in compression steel

$$\begin{aligned} \epsilon_{sc} &= \frac{x_u - d'}{x_u} \times 0.0035 = \frac{38.06 - 40}{38.06} \times 0.0035 \\ &= -1.784 \times 10^{-4} \end{aligned}$$

Minimum design strain at which compression steel yields

$$\epsilon_{sy}, \text{ mm} = \frac{0.87 \times 250}{2 \times 10^6} = 1.0875 \times 10^{-3}$$

$$\epsilon_{sc} < \epsilon_{sy \text{ min}}$$

[Infact in this case ϵ_{sc} has become tensile strain]. Hence the assumption that comp. steel has also yielded is wrong,

\therefore

$$f_{ck} < 0.87 f_y$$

In such case

$$\epsilon_{sc} = \frac{x_u - d'}{x_u} \epsilon_c = \left(1 - \frac{d'}{x_u}\right) 0.0035$$

$$\begin{aligned} f_{sc} &= E_s = \left(1 - \frac{d'}{x_u}\right) 0.0035 \\ &= 700 \left(1 - \frac{d'}{x_u}\right) \end{aligned}$$

since $E_s = 2 \times 10^5 \text{ N/mm}^2$

∴ Equating compressive and tensile forces, we get

$$0.36 f_{ck} b x_u + f_{sc} A_{sc} = 0.87 f_y A_{st}, \text{ we get}$$

$$0.36 \times 20 \times 250 x_u + 700 \times 1570 \left(1 - \frac{40}{x_u}\right) = 0.87 \times 250 \times 1885$$

$$x_u + 610.56 \left(1 - \frac{40}{x_u}\right) = 227.77$$

$$\text{or } x_u^2 + 610.56(x_u - 40) = 227.77 x_u$$

$$\text{or } x_u^2 + 382.79 x_u - 24422.40 = 0$$

$$\therefore x_u = \frac{-382.79 + \sqrt{(382.79)^2 + 4 \times 2442240}}{2}$$

$$= 57.70 \text{ mm} < x_u \text{ lim}$$

$$\therefore M_u = 0.36 f_{ck} b x_u (d - 0.42 x_u) + f_{sc} A_{sc} (d - d')$$

$$= 0.36 \times 20 \times 250 \times 57.7 (460 - 0.42 \times 57.7)$$

$$+ 197.3 \times 1570 (460 - 40)$$

$$= 173.358 \times 10^6 \text{ N mm}$$

i.e.,

$$M_u = 173.358 \text{ kN-m}$$

Example 3.10. Determine the ultimate moment capacity of a doubly reinforced beam with $b = 300 \text{ mm}$, $D = 600 \text{ mm}$, reinforced with 6 bars of 16 mm on compression side and 6 bars of 20 mm on tension side. Effective cover is 50 mm on both sides. Concrete used is M25 and steel is Fe415.

Solution.

The details of cross sections is shown in Fig. 3.18

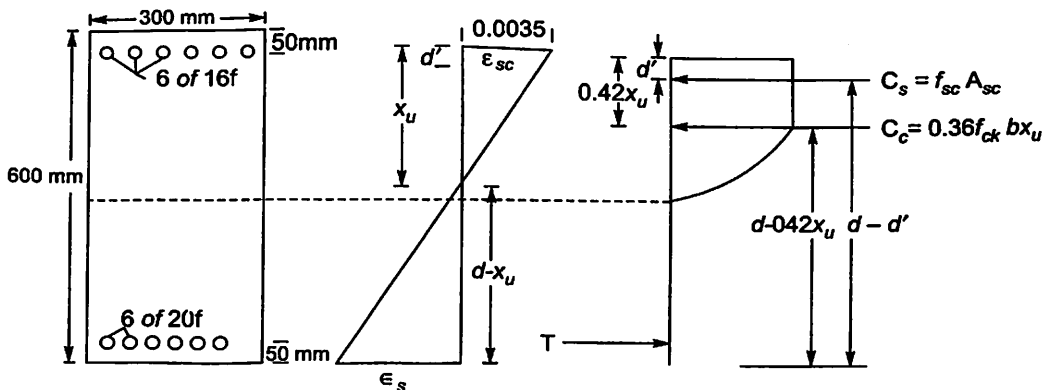

Fig. 3.18

In this, $b = 300 \text{ mm}$, $D = 600 \text{ mm}$ Cover = 50 mm

∴ $d = 550 \text{ mm}$ $d' = 50 \text{ mm}$

$$A_{sc} = 6 \times \frac{\pi}{4} \times 16^2 = 1206 \text{ mm}^2$$

and

$$A_{st} = 6 \times \frac{\pi}{4} \times 20^2 = 1885 \text{ mm}^2$$

$$f_{ck} = 25 \text{ N/mm}^2 \text{ and } f_y = 415 \text{ N/mm}^2$$

∴

$$x_{u \text{ lim}} = 0.48 d = 0.48 \times 550 = 264 \text{ mm}$$

Let us assume that compressive steel has also yielded. Then the equilibrium equation

$$C = T, \text{ gives}$$

$$0.36 f_{ck} b x_u + 0.87 f_y A_{sc} = 0.87 f_y A_{st}$$

$$0.36 \times 25 \times 300 x_u + 0.87 \times 415 \times 1206 = 0.87 \times 415 \times 1885$$

∴

$$x_u = 90.797 \text{ mm}$$

$$\epsilon_{sc} = \frac{x_u - d'}{x_u} \times 0.0035 = \frac{90.797 - 50}{90.797} \times 0.0035$$

$$= 1.573 \times 10^{-3}$$

But minimum design yield strain in Fe 415 steel is

$$\epsilon_{ey \text{ min}} = 0.002 + \frac{0.87 \times 415}{2 \times 10^5}$$

$$= 3.805 \times 10^{-3}$$

Hence compression steel has not yielded. x_u is to be found by trial and error method.

Now

$$x_{u \text{ lim}} = 264 \text{ mm}$$

Let us try

$$x_u = 250 \text{ mm}$$

$$\epsilon_{sc} = 0.0035 \left(\frac{250 - 50}{250} \right) = 2.8 \times 10^{-3}$$

∴ From table 3.4 [i.e., table A of SP-16]

$$f_{sc} = 352 \text{ N/mm}^2$$

∴ The equilibrium equation is,

$$0.36 f_{ck} b x_u + f_y A_{sc} = 0.87 f_y A_{st}$$

$$0.36 \times 25 \times 300 x_u = 0.87 \times 415 \times 1885 - 352 \times 1206$$

∴

$$x_u = 252.066 - \frac{352 \times 1206}{2700}$$

$$x_u = 94.84 \text{ mm}$$

Assumed value and calculated value of x_u differ considerably. ∴ Additional trial is required.

Let

$$x_u = 170 \text{ mm}$$

Then

$$\epsilon_{sc} = 0.0035 \left(\frac{170 - 50}{170} \right) = 2.47 \times 10^{-3}$$

From the table,

$$f_{sc} = 343 \text{ N/mm}^2$$

∴

$$x_u = 252.066 - \frac{343 \times 1206}{2700}$$

$$= 98.86$$

Not satisfactory, since the difference between assumed value and calculated value of x_u is quite large. Try another cycle

Let $x_u = 100 \text{ mm}$

$$\epsilon_{sc} = 0.0035 \left(\frac{110 - 50}{110} \right) = 1.909 \times 10^{-3}$$

From table,

$$f_{sc} = 324.5 \text{ N/mm}^2$$

Then

$$x_u = 252.066 - \frac{324.5 \times 1206}{2700} = 107.12 \text{ mm, close to assumed value of 110 mm}$$

Say

$$x_u = 109 \text{ mm}$$

$$\epsilon_{sc} = 0.0035 \frac{109 - 50}{109} = 1.894 \times 10^{-3}$$

$$f_{sc} = 323 \text{ N/mm}^2$$

\therefore

$$\begin{aligned} M_u &= 0.36 f_{ck} b x_u (d - 0.42 x_u) + f_{sc} A_{sc} (d - d') \\ &= 0.36 \times 25 \times 300 \times 109 (550 - 0.42 \times 109) \\ &\quad + 323 \times 1206 (550 - 50) \\ &= 343.16 \times 10^6 \text{ N-mm} \end{aligned}$$

Thus

$$M_u = 343.16 \text{ kN-m}$$

Ans.

Example 3.11. A rectangular beam is 200mm wide and 500mm deep. It is reinforced with 4 bars of 25mm diameter in compression with an effective cover of 50mm. Determine the area of tension reinforcement needed to make the beam section fully effective. What then would be the moment of resistance? Use M20 concrete and Fe 250 steel.

Solution.

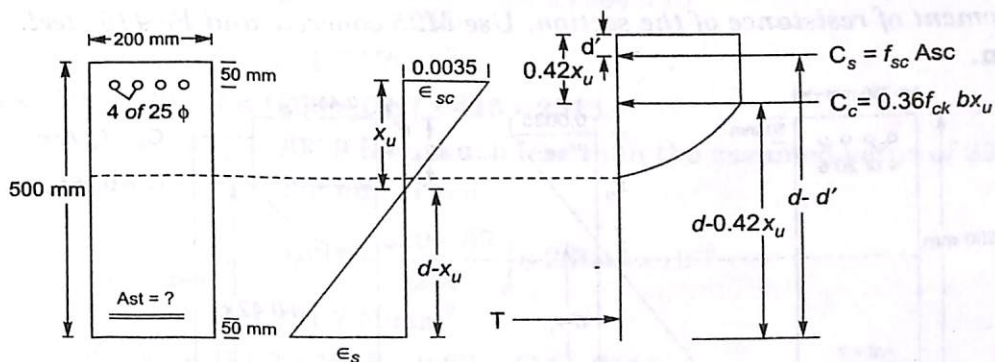

Fig. 3.19

$$b = 200 \text{ mm} \quad D = 500 \text{ mm} \quad d' = 50 \text{ mm}$$

Assuming 50 mm cover for tension reinforcement,

$$D = 450 \text{ mm} \quad f_{ck} = 20 \text{ N/mm}^2 \quad f_y = 250 \text{ N/mm}^2$$

$$A_{sc} = 4 \times \frac{\pi}{4} 25^2 = 1963 \text{ mm}^2$$

52 Design of R.C.C. Structural Elements

To make the section fully effective balanced section should be used.

$$x_u = x_{u \text{ lim}} = 0.53 d = 0.53 \times 450 = 238.5 \text{ mm}$$

$$\epsilon_{sc} = 0.0035 \left(\frac{x_u - d'}{x_u} \right) = 0.0035 \left(\frac{238.5 - 50}{238.5} \right) = 2.7662 \times 10^{-3}$$

Design strain at which steel starts yielding is

$$\epsilon_{sy \text{ lim}} = \frac{0.87 f_y}{E_s} = \frac{0.87 \times 250}{2 \times 10^5} = 1.0875 \times 10^{-3}$$

$\therefore \epsilon_{sc} > \epsilon_{sy \text{ lim}}$, Hence $f_{sc} = 0.87 f_y$
Equating compressive force to tensile force, we get,

$$0.36 f_{ck} b x_u + f_{sc} Asc = Ast 0.87 f_y$$

$$0.36 \times 20 \times 200 \times 238.5 + 0.87 \times 250 \times 1963 = Ast \times 0.87 \times 250$$

$$Ast = 3542.0 \text{ mm}^2$$

$$M_u = M_{u1} + M_{u2}$$

$$= 0.36 f_{ck} b x_u (d - 0.42 x_u) + 0.87 f_{sc} Asc (d - d')$$

$$= 0.36 \times 20 \times 200 \times 238.5 (450 - 0.42 \times 238.5)$$

$$+ 0.87 \times 250 \times 1963 (450 - 50)$$

$$= 290.927 \times 10^6 \text{ Nmm}$$

$$= 290.927 \text{ kNm}$$

Example 3.12. A rectangular R.C.C. beam is of 250 mm × 500 mm overall size, with an effective cover of 50mm on both the tension and compression sides. It is reinforced with 4 bars of 20mm bars on compression sides. Calculate the steel on tension side with 20mm bars and find the total moment of resistance of the section. Use M25 concrete and Fe 415 steel.

Ans.

Solution.

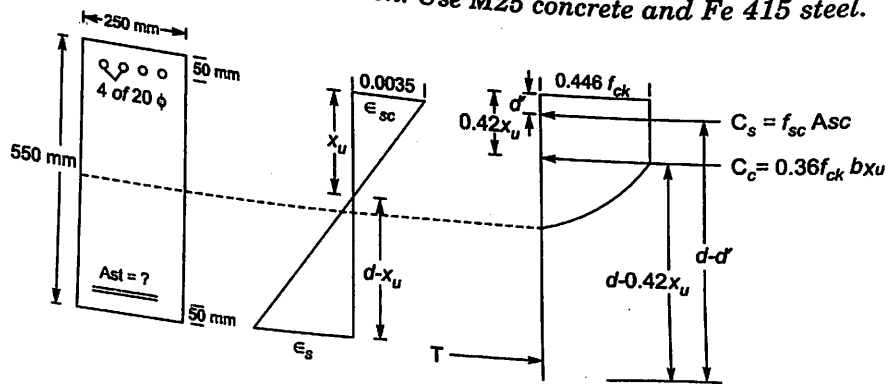

Fig 3.20

$$b = 250 \text{ mm}$$

$$\therefore d = 550 - 50 = 500 \text{ mm}$$

$$f_{ck} = 25 \text{ N/mm}^2$$

$$D = 550 \text{ mm effective cover} = 50 \text{ mm}$$

$$d' = 50 \text{ mm}$$

$$f_y = 415 \text{ N/mm}^2$$

$$A_{sc} = \frac{\pi}{4} \times 4 \times 20^2 = 1256 \text{ mm}^2$$

To make the beam section fully effective, it should be balanced section. For such section,

$$x_u = x_{u \text{ lim}} = 0.48 \quad d = 0.48 \times 500 = 240 \text{ mm}$$

∴ Strain in compression steel

$$\begin{aligned} \epsilon_{sc} &= \frac{x_u - d'}{x_u} \times 0.0035 = \left(\frac{240 - 50}{240} \right) \times 0.0035 \\ &= 2.7708 \times 10^{-3} \end{aligned}$$

From the table 3.4 (or from stress strain curve)

$$f_{sc} = 351.9 \text{ N/mm}^2$$

Equating compressive force to tensile force, we get,

$$0.36 f_{ck} b x_u + f_{sc} A_{sc} = 0.87 f_y A_{st}$$

$$0.36 \times 25 \times 250 \times 240 + 351.9 \times 1256 = 0.87 \times 415 \times A_{st}$$

$$\therefore A_{st} = 2720 \text{ mm}^2$$

No. of 20 mm dia bars required

$$\begin{aligned} &= \frac{2720}{\frac{\pi}{4} \times 20^2} = 8.65 \end{aligned}$$

To keep the section under reinforced, select only 8 bars. Then,

$$A_{st} = \frac{\pi}{4} \times 8 \times 20^2 = 2513 \text{ mm}^2$$

Exact x_u is to be found by trial and error method. Let $x_u = 236 \text{ mm}$ (which is slightly less than $x_{u \text{ lim}}$)

$$\epsilon_{sc} = 0.0035 \left(\frac{236 - 50}{236} \right) = 2.7584 \times 10^{-3}$$

$$\text{Then } \therefore f_{sc} = 351.7 \text{ N/mm}^2$$

$$\therefore 0.36 \times 25 \times 250 x_u + 351.7 \times 1256 = 0.87 \times 415 \times 2513$$

$$\therefore x_u = 206.9 \text{ mm, much less than the assumed value of 236 mm}$$

$$\text{Try } x_u = 220 \text{ mm. Then}$$

$$\epsilon_{sc} = 0.0035 \left(\frac{220 - 50}{220} \right) = 2.7045 \times 10^{-3}$$

$$\therefore f_{sc} = 351.7 \text{ N/mm}^2$$

$$\therefore 0.36 \times 25 \times 250 \times x_u + 351.7 \times 1256 = 0.87 \times 415 \times 2513$$

$$x_u = 207.15 \text{ mm}$$

$$x_u \text{ assumed} = 220 \text{ mm}$$

∴ One more trial is required

Let x_u be assumed as 210 mm.

$$\epsilon_{sc} = \frac{210 - 50}{210} \times 0.0035 = 2.667 \times 10^{-3}$$

$$f_{sc} = 349.23 \text{ N/mm}^2$$

∴ The equilibrium equation $C = T$ gives,

$$0.36 \times 25 \times 250x_u + 349.23 \times 1256 = 0.87 \times 415 \times 2513$$

$$x_u = 208.30$$

Let us take

$$x_u = 209 \text{ mm. Then, } f_{sc} = 349.23 \text{ N/mm}^2$$

$$M_u = 0.36 \times 25 \times 250 \times (500 - 0.42 \times 209) + 349.23 \times 1256 (500 - 50)$$

$$= 391.23 \times 10^6 \text{ Nmm} = 391.23 \text{ kN - m}$$

QUESTIONS

1. A singly reinforced concrete beam has a width 300 mm and overall depth 550 mm with a clear cover of 40 mm is reinforced with 4 bars of 20 mm diameter. Find the flexural strength and hence the safe *udl* on the simply supported beam of span 5m. Use M20 concrete and mild steel.
2. In the problem no.1, if Fe 415 steel is used in place of mild steel, determine the load carrying capacity.
3. If the beam in problem no.1 is cast with M25 concrete and Fe 415 steel, what will be the load carrying capacity?
4. A T-beam has flange dimensions of 1500 × 120mm. The width of rib is 250 mm and rib depth is 350mm. If the beam is reinforced with 1900mm² of steel in tension zone with an effective cover of 40mm, determine the maximum allowable *udl* inclusive of self weight over a simply supported span of 6m. M20 grade concrete and Fe 415 steel is used.
5. A doubly reinforced beam is 300mm wide and 500mm deep overall. It is reinforced with 4 bars of 20mm diameter on the tension side and 2 bars of 20mm diameter on compression side with an effective cover to steel as 35mm. Determine all inclusive *udl* the beam can carry over a simply supported effective span of 3.5m. Adopt M20 concrete and Fe 415 steel.

Strength of R.C. Section in Shear, Torsion and Bond

4.1 INTRODUCTION

Bending is usually associated with shear. Hence R.C. section should be strong enough to resist the limit state of collapse in shear also. Some of the beams are subjected to torsion also. Hence the designer must know how to assess the strength of R.C. section in the limit state of torsion. Design of all R.C. sections is based on the assumption that there is perfect bond between steel reinforcement and concrete. This is possible only if the bond stress is within the limit. Hence designer must be able to assess this bond strength. In this chapter the IS 456 – 2000 code provisions to assess the strength of R.C. sections in shear torsion and bond is presented and illustrated with examples.

4.2 STRENGTH OF CONCRETE SECTIONS IN SHEAR

In structural analysis, the method of finding bending moments and shear forces at various sections have been studied by the readers. If a simply supported beam subjected to uniformly distributed load is considered, shear force and bending moment diagrams are as shown in Fig. 4.1.

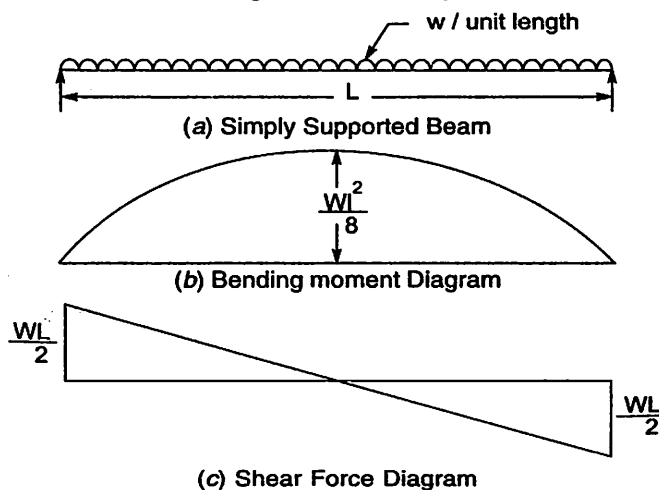

Fig. 4.1. Simply Supported Beam Subject to udl.

In this case bending moment is maximum at mid span where as shear force is maximum at the support. The state of stresses and likely crack patterns at four critical section are shown in Fig. 4.2. The failure

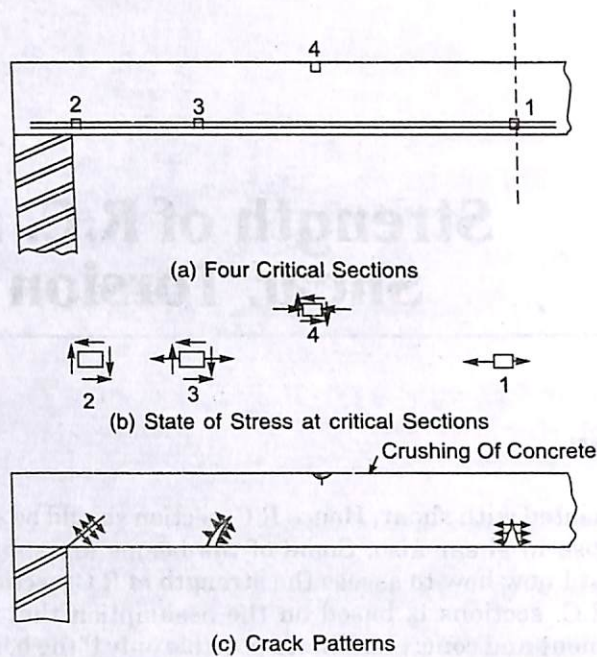

Fig. 4.2. Crack Patterns at Critical Sections.

Criteria to be considered at the four critical points are:

Point 1 : Flexure Failure

Point 2 : Shear Failure

Point 3 : Shear Plus Tensile failure

Point 4 : Shear Plus Compression Failure.

A case of complete shear failure is shown in Fig. 4.3. Hence there is need to avoid shear

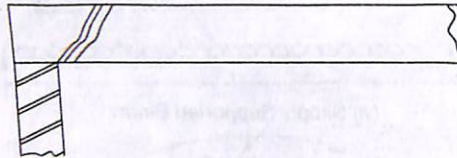

Fig. 4.3. Case of Complete Shear Failure.

failure. Actual design is to be based on principal stresses developed. However a practical design procedure is presented by IS 456 - 2000 based on average shear stresses across the section. Average shear stress τ_v is given by the expression.

$$\tau_v = \frac{V_u}{bd}$$

4.1

Where V_u = design (Factored) shear force
 B = breadth (b_w for T or L beams)

and d = effective depth

In case of varying depth the equation 4.1 is modified as

$$\tau_u = \frac{V_u \pm \frac{M_u}{d} \tan \beta}{bd} \quad 4.2$$

Where M_u = bending moment in the section

β = angle between the top and bottom edges as shown in Fig. 4.4.

The negative sign in the formula applies when the bending moment M_u increases numerically in the same direction as the effective depth d increases, and the positive sign when the moment decreases numerically in this direction.

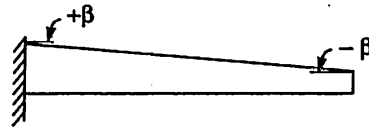

Fig. 4.4. Sign of β in Beam with Varying Depth.

Concrete is capable of resisting shear force to some extent. This value depends to a great extent on the confinement of concrete by the longitudinal tensile steel provided for resisting bending moment. However in finding this percentage of steel $\left(p_t = \frac{A_{st}}{bd} \times 100 \right)$ at any section under consideration, it should be noted carefully that the steel continues at least one effective depth beyond the section.

These values for various concrete mixes as recommended by IS code are shown in Table 4.1. However the values for M15 are not listed, since M15 is not to be used in R.C. design.

Table 4.1 Design shear strength of Concrete τ_c , N/mm²

(Table 19 in IS 456 - 2000).

$100 \frac{A_{st}}{bd}$	M15	M20	M25	M30	M35	M40 and above
≤ 0.15	0.28	0.28	0.29	0.29	0.29	0.30
0.25	0.35	0.36	0.36	0.37	0.37	0.38
0.50	0.46	0.48	0.49	0.50	0.50	0.51
0.75	0.54	0.56	0.57	0.59	0.59	0.60
1.00	0.60	0.62	0.64	0.66	0.67	0.68
1.25	0.64	0.67	0.70	0.71	0.73	0.74
1.50	0.68	0.72	0.74	0.76	0.78	0.79
1.75	0.71	0.75	0.78	0.80	0.82	0.84
2.00	0.71	0.79	0.82	0.84	0.86	0.88
2.25	0.71	0.81	0.85	0.88	0.90	0.92
2.50	0.71	0.82	0.88	0.91	0.93	0.95
2.75	0.71	0.82	0.90	0.94	0.96	0.98
3.00 and above	0.71	0.82	0.92	0.96	0.99	1.01

Note: The term A is the area of longitudinal tension reinforcement which continues at least one effective depth beyond the section being considered except at support where the full area of tension reinforcement may be used provided the detailing conforms to clauses 26.2.2 and 26.2.3 of IS456-2000.

4.3 SHEAR STRENGTH OF REINFORCED CONCRETE SECTIONS

The shear strength V_u of the R.C. section can be enhanced by providing shear reinforcements in any of the following forms as shown in Fig. 4.5 to 4.7

- (a) Vertical stirrups
- (b) Bent up bars along with stirrups and
- (c) Inclined stirrups.

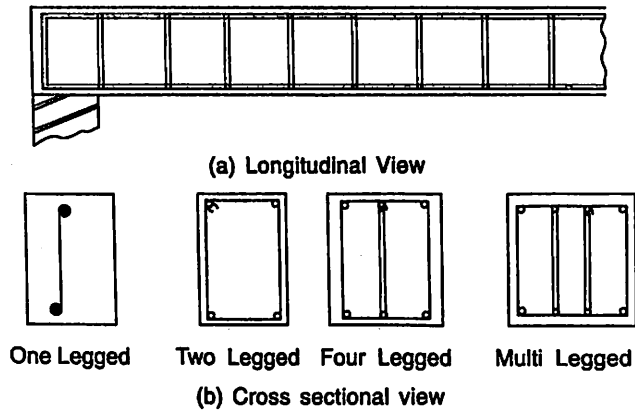

Fig. 4.5. Vertical Stirrups.

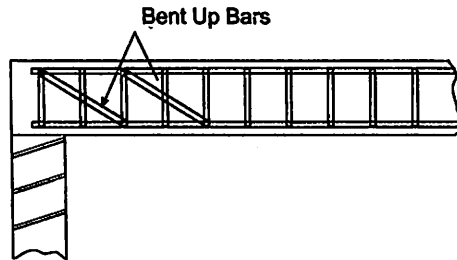

Fig. 4.6. Bent up Bars and Vertical Stirrups.

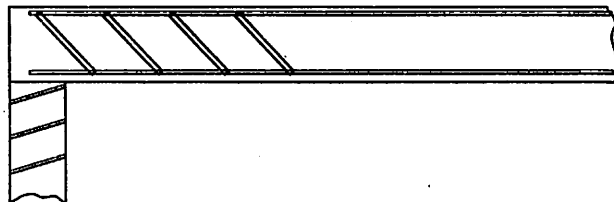

Fig. 4.7. Inclined Stirrups.

To determine the enhanced strength of R.C. section due to provision of reinforcements, consider a beam with inclined reinforcements as shown in Fig. 4.8

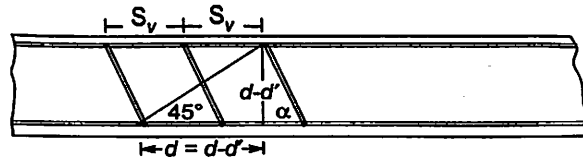

Fig. 4.8.

Let,

S_v = spacing of stirrups

A_{sv} = total cross-sectional area of stirrup legs or bent-up bars within a distance S_v .

α = angle between the inclined stirrup or bent-up bar and the axis of the member, not less than 45° .

Since the R.C. members are to be designed for ductile failure and not for sudden failure of concrete in compression, the shear reinforcement is also designed for yielding. Hence at limiting state of shear, vertical component of shear resisted by stirrup legs is given by

$$= A_{sv} 0.87 f_y \sin \alpha \quad 4.3$$

Now consider the equilibrium of vertical forces across a potential diagonal crack which is assumed to extend at angle of 45° with the axis of the beam, as shown in Fig. 4.8.

Let 'n' be number of shear reinforcements crossing the crack. Hence total vertical shear force resisted in one crack width, V_{us} is given by

$$V_{us} = n A_{sv} 0.87 f_y \sin \alpha \quad 4.4$$

From Fig. 4.8,

$$\begin{aligned} n S_v &= (d - d') \cot 45 + (d - d') \cos \alpha \\ &= (d - d') (\cot 45 + \cos \alpha) \\ &= (d - d') (1 + \cos \alpha) \\ &\approx d (1 + \cos \alpha) \end{aligned}$$

$$\therefore V_{us} = \frac{d(1 + \cos \alpha)}{S_v} A_{sv} 0.87 f_y \sin \alpha \quad 4.4 (a)$$

For vertical stirrups, $\alpha = 90^\circ$

$$\therefore V_{us} = \frac{0.87 f_y A_{sv}}{S_v} d \quad 4.4 (b)$$

For inclined stirrups

$$V_{us} = \frac{0.87 f_y A_{sv}}{S_v} d (\sin \alpha + \cos \alpha) \quad 4.4 (c)$$

where A_{sv} is cross section area of bent up bars at the cross sections.

However code specifies **where bent up bars are provided, their contribution towards shear resistance shall not be more than half that of the total shear reinforcement**

Code also specify that to avoid compression failure of the section in shear, under no circumstances, even with shear reinforcement, the nominal shear stress τ_v exceeds $\tau_{c, \max}$ values given in the table 4.2 (Table 20 in IS 456 - 2000)

Table 4.2 Maximum shear $\tau_{c \max}$, N/mm²

Concrete Grade	M20	M25	M30	M35	M40 on words
$\tau_{c \max}$	2.8	3.1	3.5	3.7	4.0

Thus, the shear strength of R.C. section at limit state of collapse in shear is given by

$$V_u = V_{uc} + V_{us}, \text{ subject to a maximum of } \tau_{c \max} bd \quad 4.5$$

Where

$$V_{uc} = \text{shear strength of concrete}$$

$$= \tau_c bd$$

and

$$V_{us} = \text{shear strength of steel}$$

Example 4.1. A R.C.C. beam 250 mm wide and 450 mm deep, is reinforced with 3 Nos. of 20 mm diameter bars of grade Fe 415, on the tension side with an effective cover of 50 mm. If the shear reinforcement of 2 legged 8 mm stirrups at a spacing of 160 mm c/c is provided at a section, determine the design (ultimate) strength of the section. Assume M20 concrete has been used.

Solution.

The beam cross section is as shown in Fig. 4.9.

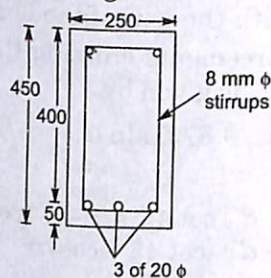

Fig. 4.9.

In this case,

$$b = 250 \text{ mm } D = 450 \text{ mm}$$

$$\text{Effective cover} = 50 \text{ mm}$$

$$d = 450 - 50 = 400 \text{ mm}$$

$$f_{ck} = 20 \text{ N/mm}^2, f_y = 415 \text{ N/mm}^2$$

$$A_{st} = 3 \text{ of } 20 \text{ mm}$$

$$= 3 \times \frac{\pi}{4} \times 20^2 = 942 \text{ mm}^2$$

$$p_t = \frac{A_{st}}{bd} \times 100 = \frac{942}{250 \times 400} \times 100 = 0.942$$

∴ From table 4.1 (i.e. table 19 of IS 456)

$$\tau_c = 0.61 \text{ N/mm}^2$$

$$V_{uc} = 0.61 \times 250 \times 400 = 61,000 \text{ N} = 61 \text{ kN}$$

∴ Strength due to shear reinforcement

$$V_{us} = \frac{0.87 f_y A_{sv} d}{S_v}$$

Now

$$A_{sv} = 2 \times \frac{\pi}{4} \times 8^2 = 100.53$$

$$S_v = 160 \text{ mm}$$

$$\therefore V_{us} = \frac{0.87 \times 415 \times 100.53 \times 400}{160} = 90.742 \text{ N} = 90.742 \text{ kN}$$

$$\therefore V_u = V_{uc} + V_{us} = 61 + 90.742 = 151.742 \text{ kN.}$$

From table 4.2 (table 20 of IS 456)

$$\tau_{c, \max} = 2.8 \text{ N/mm}^2$$

\(\therefore\) Upper limit for the strength of section,

$$\begin{aligned} V_{\max} &= \tau_{c, \max} b d \\ &= 2.8 \times 250 \times 400 = 280000 \text{ N} \\ &= 280 \text{ kN.} > 151.742 \text{ kN} \end{aligned}$$

\(\therefore\) The design strength of the section for shear is, 151.742 kN

Ans.

Example 4.2. In the above example, if one of the tensile bar is bent up at the section at 45° , what is the design strength of the section in shear?

Solution.

$$\alpha = 45^\circ. A_{sb} = \frac{\pi}{4} \times 20^2 = 314 \text{ mm}^2$$

Strength due to bent up bar

$$\begin{aligned} V_{ub} &= 0.87 f_y A_{sb} \sin \alpha \\ &= 0.87 \times 415 \times 314 \sin 45^\circ \\ &= 80164 \text{ N} = 80.164 \text{ kN.} \end{aligned}$$

This is more than $\frac{1}{2} V_{us}$ i.e., $\frac{1}{2} \times 90.745$

$$\therefore V_{us} = \frac{1}{2} V_{us} = \frac{90.745}{2} = 45.371 \text{ kN}$$

$$\begin{aligned} V_u &= V_{uc} + V_{us} + V_{ub} \\ &= 61.0 + 90.742 + 45.371 \\ &= 197.113 \text{ kN.} \end{aligned}$$

Ans.

Example 4.3. A 250 mm wide and 600 mm deep R.C. beam is reinforced with 2 legged 10 mm inclined stirrups at 250 mm c/c with $\alpha = 60^\circ$. Longitudinal steel consists of 4 bars of 20 mm with a cover of 40 mm. If concrete grade is M25 and grade of steel is Fe 415, determine the strength of the section in shear.

Solution.

Fig. 4.10 shown the cross section of the beam.

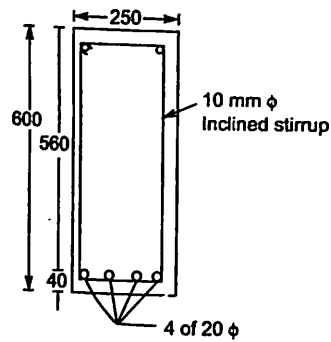

Fig. 4.10.

In this case,

$$b = 250 \text{ mm}, \quad D = 600 \text{ mm}$$

$$\text{Cover} = 40 \text{ mm}$$

\therefore

$$d = 600 - 40 = 560 \text{ mm.}$$

$$f_{ck} = 25 \text{ N/mm}^2$$

$$f_y = 415 \text{ N/mm}^2$$

$$A_{st} = 4 \times \frac{\pi}{4} \times 20^2 = 1256$$

\therefore Percentage steel

$$p_t = \frac{1256}{250 \times 560} \times 100 = 0.897$$

\therefore From the table 4.1 (table 19 of IS 456)

$$\tau_c = 0.61 \text{ N/mm}^2.$$

\therefore Strength of concrete in shear

$$V_{uc} = \tau_c b d$$

$$= 0.61 \times 250 \times 560 = 85400 \text{ N}$$

$$= 85.400 \text{ kN.}$$

Strength of section due to inclined stirrups.

$$V_{us} = \frac{0.87 f_y A_{sy} d}{S_v} (\sin 60 + \cos 60)$$

$$= \frac{0.87 \times 415 \times 2 \times \frac{\pi}{4} \times 10^2 \times 560}{250} (\sin 60 + \cos 60)$$

$$= 173538 \text{ N} = 173.538 \text{ kN}$$

\therefore

$$V_u = V_{uc} + V_{us}$$

$$= 85.4 + 173.538$$

$$= 258.938 \text{ kN.}$$

$$\begin{aligned} \therefore V_{u' max} &= \tau_{c max} bd \\ &= 3.1 \times 250 \times 560 \\ &= 434000 \text{ N} > V_u \end{aligned}$$

\therefore Design strength of the section in shear.

$$V_u = 258.938 \text{ kN}$$

Ans.

4.4 TORSIONAL STRENGTH OF R.C. SECTION

The moment causing twisting of the cross section is called torsional moment. Actually, if rigorous three dimensional analysis of building frames is carried out, it will be observed that all beams are subjected to some torsional moment also. However in many cases these values are small and designers have been carrying out only plane frame analysis. But there are many cases in which torsional moment cannot be ignored. Some of these examples are

- (i) a beam with cantilever slab (Fig. 4.11. a)
- (ii) balcony girders (Fig. 4.11. b)
- (iii) ring beams of water tanks resting on columns (Fig. 4.11. c)

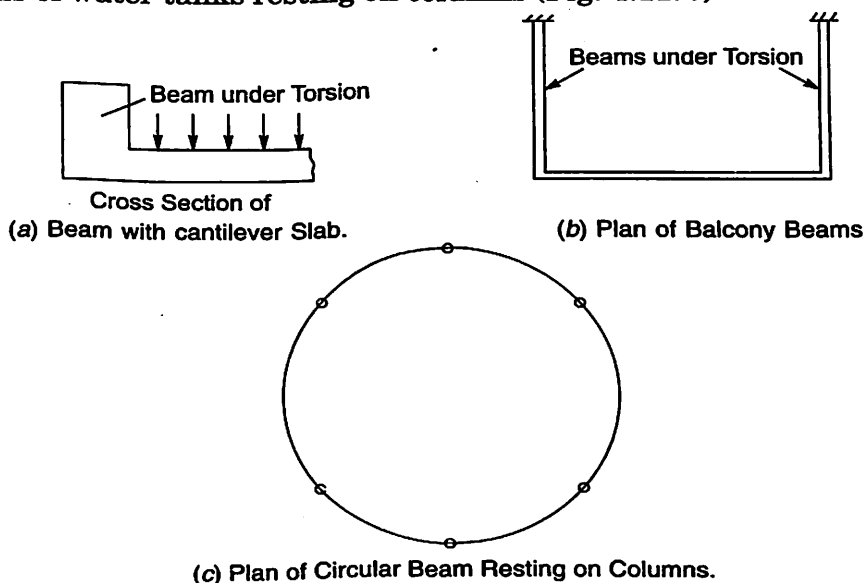

Fig. 4.11. Beams Under Torsion.

Readers are familiar with the following torsional equation for circular bars :

$$\frac{T}{J} = \frac{q}{r} = \frac{G\theta}{L}$$

4.5

where T – torsional moment
 J – polar moment of inertia
 q – shear stress due to torsion
 r – radial distance of the point
 G – modulus of rigidity
 θ – angle of twist and
 L – length of the bar

It should be carefully noted that the above formula is applicable only for the bars of circular sections, in which warping of the section do not take place. For the members with rectangular section or the built up sections with rectangular components the above equation is used with different meaning for the terms 'J'. J is called torsion factor. More accurate expression for torsion factor for a rectangular section is

$$J = \frac{1}{3} b^3 d \left[1 - \frac{192}{\pi^5} \frac{b}{d} \sum_{n=1,3,\dots}^{\infty} \left(\frac{1}{n^5} \right) \tanh \frac{n\pi d}{2b} \right] \quad 4.6$$

where b is smaller dimension and d is larger dimension. The following two simplified equations are also used

$$J = \frac{b^3 d^3}{3.58 (b^2 + d^2)} \quad 4.7(a)$$

and

$$J = \frac{b^3 d}{3} \left(1 - 0.63 \frac{b}{a} \right) \quad 4.7(b)$$

Equation 4.7 (a) gives better results for $\frac{d}{b}$ 1 to 1.6 and equation 4.7 (b) gives better results for $\frac{d}{b} > 1.6$.

In R.C. structural members, torsion is usually associated with bending moment and shear force. It is also observed that torsion is secondary to flexure. Hence there is no need to study strength of R.C. members under pure torsion. Based on several research works, all national codes have accepted simple formulae to take care of torsional effect on R.C. beams. IS code 456 - 2000 (Clause 41.4.2 and 41.3.1) recommends the effect of torsional moment may be split into

a bending moment of $M_t = T_u \frac{1 + D/b}{1.7}$ and a shear force of $1.6 \frac{T_u}{b}$

where T_u = design (ultimate) torsional moment

b = breadth of beam or breadth of web in case of flanged sections

D = overall depth of beam.

If M_u is design bending moment and V_u is design shear due to flexure and T_u is design torsional moment, it may be assumed that the beam is subjected to an equivalent moment and shear forces M_e and T_e

where,

$$M_e = M_u + T_u \frac{1 + D/b}{1.7} \quad 4.8(a)$$

and

$$V_e = V_u + 1.6 \frac{T_u}{b} \quad 4.8(b)$$

Then the beam section is designed for the bending moment M_e and shear force V_e .

Example 4.5 A R.C. beam has cross section 300 mm × 600 mm and is subjected to the following design forces:

Bending Moment = 115 kN-m,

Shear Force = 95 kN-m,

and Torsional Moment = 45 kN-m.

Determine the equivalent bending moment and shear force for which section is to be designed.

Solution:

Now, $M_u = 115 \text{ kN-m}$, $V_u = 95 \text{ kN}$ and $T_u = 45 \text{ kN}$.

$\therefore b = 300 \text{ mm}$ and $D = 600 \text{ mm}$.

$$M_e = M_u + T_u \left(\frac{1 + D/b}{1.7} \right)$$

$$= 115 + 45 \left(\frac{1 + 600/300}{1.7} \right)$$

$\therefore M_e = 194.41 \text{ kN-m}$

Ans.

$$V_e = V_u + 1.6 \frac{T_u}{b}$$

$$= 95 + 1.6 \frac{45}{0.3}$$

$\therefore V_e = 335 \text{ kN}$

Ans.

4.5 BOND STRENGTH IN R.C. MEMBERS

The theory of reinforced concrete is developed with the assumption that there is perfect bond between steel and concrete, in other words, there is no slip. The plane section before bending remains plane after bending also, if and only if, there is no slip. The stress developed between the contact surfaces of steel and concrete to keep them together is called bond stress. There is a limit upto which such stress can develop and beyond that there will be slip. The design has to take care of the following two cases of bond failures:

- (a) Flexural Bond and
- (b) Anchorage Bond.

Flexural Bond

Consider the two adjacent sections at distances x and $x + \Delta x$ from a reference point (Ref. Fig. 4.12)

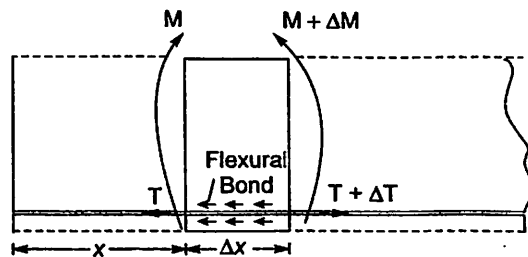

Fig. 4.12. Flexural Bond.

Let M be the moment at section x and $M + \Delta M$ at section $x + \Delta x$. If lever arm $LA = jd$, then the tensile forces T and ΔT developed at sections x and $x + \Delta x$ are given by

$$T \times jd = M$$

$$(T + \Delta T) jd = M + \Delta M$$

$$\therefore \Delta T jd = \Delta M$$

4.9(a)

If τ_{bf} is the bond stress developed along the periphery of steel, which is in contact with steel, then from the equilibrium condition,

$$T + \tau_{bf} \Delta x \sum 0 = T + \Delta T$$

or

$$\Delta T = \tau_{bf} \Delta x \sum 0$$

4.9(b)

From equations 4.9 (a) and (b), we get,

$$\tau_{bf} \Delta x \sum 0 jd = \Delta M$$

$$\tau_{bf} = \frac{1}{jd \sum 0} \frac{\Delta M}{\Delta x}$$

4.10.

$$\tau_{bf} = \frac{V}{dj \sum 0}$$

Since

$$\frac{\Delta M}{\Delta x} = \text{rate of change of moment.}$$

= Shear.

However it is to be noted that the above expression is valid only for mild steel and not for ribbed bars. The reason is in ribbed bars there is considerable increase in resistance to flexural bond due to projections on it. In case of ribbed bars there is no need to check for this flexural bond.

Flexural bond is also known as local bond, since it varies from section to section, and the expression 4.10 gives this type of stress.

Anchorage Bond.

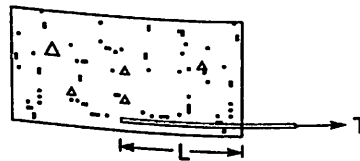

Fig. 4.13. Anchorage Bond.

From Fig 4.13 it is obvious that the bar needs sufficient anchorage length to resist the force T applied. If the length is short it will slip. The minimum anchorage length required to resist design force in the bar is called **anchorage length**. For the simplicity of calculation this anchorage length is determined based on the **average bond stress** developed. Average bond stress can be determined easily by pull out tests. Table 4.3 shown the design bond stress in limit state method for plain bars in tension as given by IS 456 - 2000 (Clause 26.2.1.1).

**Table 4.4. Design Bond Stress in Plain Bars
In Tension. (Clause 26.2.1.1 in IS 456-2000)**

Grade of Concrete	M20	M25	M30	M35	M40 and above
Design Bond Stress τ_{bd} , N/mm ²	1.2	1.4	1.5	1.7	1.9

Note: For deformed bars the values shall be 1.6 times the above values.

From the equilibrium condition for horizontal forces (Ref. Fig. 4.13),

$$T = \tau_{bd} \pi \phi L$$

Where ϕ is the diameter of the bar. Noting that $L = L_d$, the development length, when, T is tension permitted in the steel i.e. $T = 0.87 f_y \frac{\pi \phi^2}{4}$, we get.

$$0.87 f_y \frac{\pi \phi^2}{4} = \tau_{bd} \pi \phi L_d \quad \text{or} \quad L_d = \frac{0.87 f_y \phi}{4 \tau_{bd}} \quad 4.11.$$

Hence all bars should extend to a distance of L_d beyond the section where they are required to take full design force. Fig. 4.14 shows some of such situations.

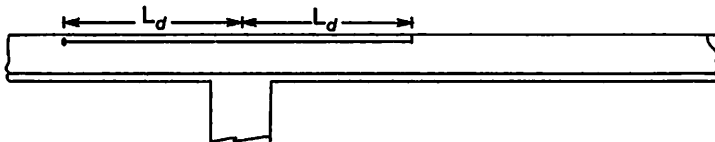

(a) For negative reinforcements near supports.

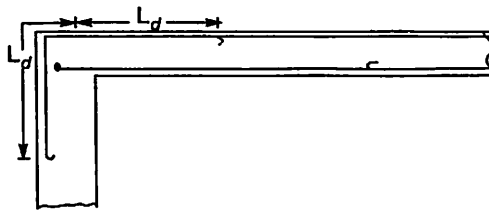

(b) Anchorage length in columns for -ve Reinforcements of beam.

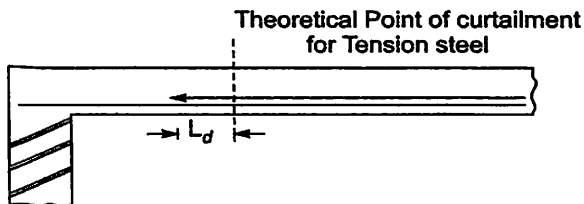

(c) Anchorage Length for curtailed Beam.

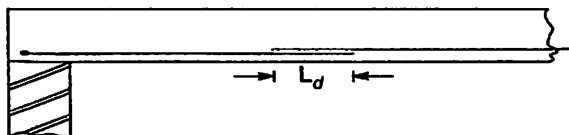

(d) Anchorage Length for Lap Splicing

Fig. 4.14. Anchorage Length Required.

Equivalent Development Length of Hooks and Bends

To improve the anchorage of the bars many times standard hooks are provided in plain bars and standard bends are provided in high yield bars as shown in Fig. 4.15. The improved anchorage is due to bearing stresses developed between concrete and steel. The equivalent development lengths for these standard hooks and bends may be taken as (IS 456 - 2000, clause No. 26.2.2) given below:

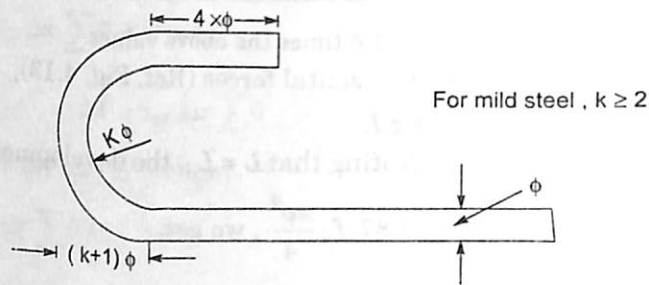

(a) Standard Hook.

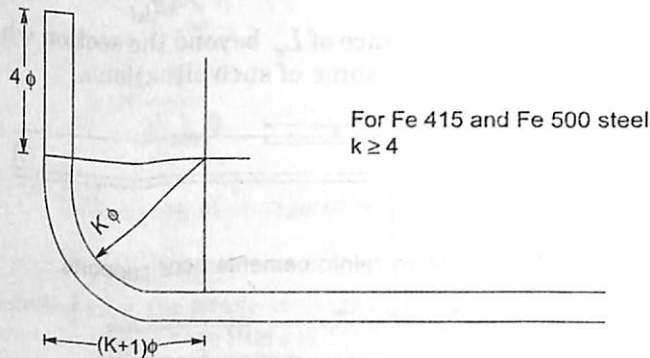

(b) Standard bend.

Fig. 4.15. Standard Hook and Bend.

- The anchorage value of a standard U - type hook shall be equal to 16 times the diameter of the bar
- The anchorage value of the standard bend shall be taken as 4 times the diameter of the bar for each 45° bend subject to a maximum of 16 times the diameter of the bar.

Development Length of Compression Bars

IS-456 makes the following provisions for finding development length of compression bars

- the value of bond stress permitted in compression is 25 per cent more than the values shown in table 4.4 (clause 26.2.1.1)
- Only the projected length of hooks, bends and straight lengths beyond bends, if provided, shall be considered as equivalent development lengths.

Example 4.6 An overhanging beam has 6m span from support to support and an overhang of 2 m. It carries a design load of 40kN/m throughout. The cross section of the beam selected is 250 mm × 450 mm. To carry the cantilever moment 4 bars of 20 mm plain bars are provided with 50 mm effective cover. What is the maximum bond stress developed? Determine anchorage length required for cantilever reinforcement

(a) If hooks are not provided.

(b) If standard hooks are provided.

Assume $f_{ck} = 25 \text{ N/mm}^2$ and $f_y = 250 \text{ N/mm}^2$ and the balanced section.

Solution.

Fig. 4.16 shows the overhanging beam.

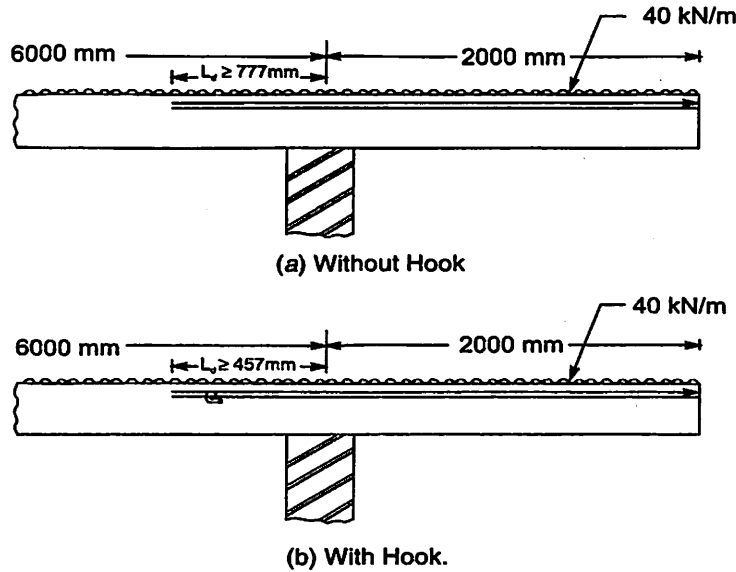

Fig. 4.16

In this case, the maximum shear force at the support of overhanging beam is,

$$V_u = 40 \times 2 = 80 \text{ kN}$$

Effective depth = $450 - 50 = 400 \text{ mm}$.

Total perimeter of the bars in contact with concrete = $\sum 0 = 4 \times \pi \phi = 4\pi 20$
 $= 251.3 \text{ mm}$.

Since it is balanced section,

$$x_u = x_{u \text{ lim}} = 0.53d$$

\therefore

$$\begin{aligned} \text{Lever Arm} &= jd = d - 0.42 x_u \\ &= (1 - 0.42 \times 0.53) d \\ &= 0.7774 d. \end{aligned}$$

\therefore Flexural bond stress τ_{bf} is given by

$$\begin{aligned} \tau_{bf} &= \frac{V}{jd \sum 0} = \frac{80 \times 1000}{0.7774 \times 400 \times 251.3} \\ &= 1.023 \text{ N/mm}^2 \end{aligned}$$

Anchorage Length L_d :

(a) If no hook is provided :

Design bond stress for M25 is (Table 4.4)

$$\tau_{bd} = 1.4 \text{ N/mm}^2$$

Equating bond resistance to design tensile force we get

$$L_d \tau_{bd} \pi \phi = 0.87 f_y \frac{\pi \phi^2}{4}$$

$$L_d = \frac{0.87 f_y \phi}{4 \tau_{bd}} = \frac{0.87 \times 250 \times 20}{4 \times 1.4}$$

$$L_d = 777 \text{ mm (as shown in Fig. 4.16. a)}$$

Ans.

(b) If standard hook is provided,

$$\text{Its equivalent length} = 16 \phi$$

$$= 16 \times 20 = 320 \text{ mm.}$$

\therefore Length of bar required beyond support

$$= 777 - 320$$

$$= 457 \text{ mm as shown in Fig. 4.16 (b),}$$

Ans.

Example 4.7. In the above problem, if the cantilever portion is supported by column of width 400 mm, determine the anchorage length and sketch the anchorage details.

Solution.

As in the previous problem,

$$L_d = 777 \text{ mm.}$$

Anchorage details are shown in Fig. 4.17

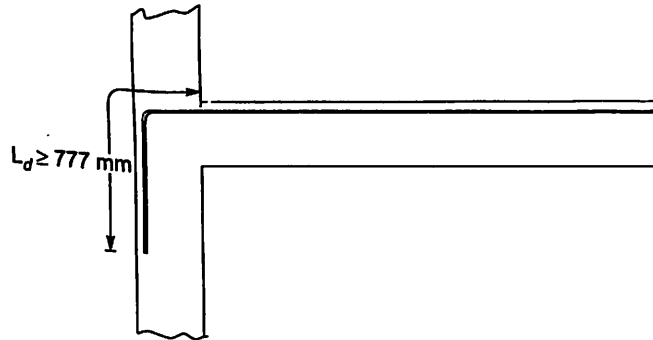

Fig. 4.17

Example 4.8. Column of a multistory building is reinforced with 25 mm diameter Fe 415 bars. Calculate the lap length required and sketch the details. M25 concrete mix is used.

Solution.

$$\text{Load carried by a bar} = 0.87 f_y \cdot A_{st}$$

$$= 0.87 f_y \frac{\pi \phi^2}{4}$$

$$\text{Anchorage resistance} = \tau_{bd} \pi \phi L_d$$

$$\therefore \tau_{bd} \pi \phi L_d = 0.87 f_y \frac{\pi \phi^2}{4}$$

or
$$L_d = \frac{0.87 f_y \phi}{4 \tau_{bd}}$$

τ_{bd} for M25 concrete in tension = 1.4×1.6

$\therefore \tau_{bd}$ for M25 concrete in compression = $1.4 \times 1.6 \times 1.25$

(25 % more than in tension)

$$f_y = 415 \text{ N/mm}^2$$

$$\therefore L_d = \frac{0.87 \times 415 \times 25}{4 \times 1.4 \times 1.6 \times 1.25} = 806 \text{ mm.}$$

\therefore Provide $L_d \geq 806 \text{ mm.}$

The details of lap are shown in Fig. 4.18

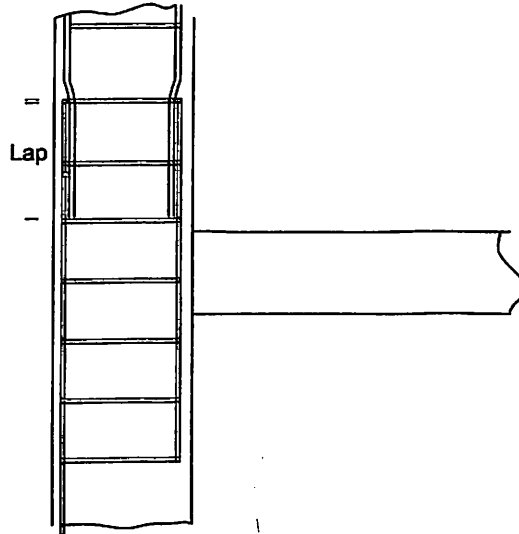

Fig. 4.18

QUESTIONS

1. Briefly explain the reasons for the development of diagonal tension cracks in R. C. beams.
2. Sketch the various types of shear reinforcement normally provided in practice.
3. Explain the various types of shear failures and shear design of R.C.C. beams.
4. Briefly explain how the torsional moment is taken care in the design of beams.
5. A R.C. beam $250 \times 550 \text{ mm}$ is reinforced with 4 bars of 25mm diameter bars of Fe 415 grade steel. Effective cover is 50mm and M20 concrete is used. It is provide with 2 legged 8mm stirrups at a spacing of 150mm. Determine ultimate strength of the section.
6. In the above example if two of the bars are bent up at 45° at a section, what is the strength of the section in shear?
7. A R.C. beam of size $300 \text{ mm} \times 500 \text{ mm}$ is subjected to the following factored loads:

$$M_u = 100 \text{ kN-m}$$

$$T_u = 40 \text{ kN-m}$$

and

$$V_u = 80 \text{ kN-m}$$

Determine the equivalent bending moment and shear force for which the section is to be designed.

8. A column of size 250×500 mm supports a cantilever beam of span 2.5 m. The cross section of the beam is 230×500 mm and is reinforced with 4 bars of 20 mm Fe 415 steel. Concrete used is of grade M20. Assuming effective cover is 50 mm. Calculate the anchorage length required and sketch how it is provided.

Limit States of Serviceability

5.1 INTRODUCTION

As explained in Chapter II, among the various limits states the limit states of deflection and cracking are important in R.C. Designs. In this chapter various limits for deflections (as prescribed by IS 456-2000) are presented and method of calculating the deflections are explained. Designers can safely assume limit state of deflection safe, if span to depth ratio of beams are within prescribed values by IS code. This aspect of ensuring safety against failure due to deflection is explained with examples. Cracking in structural concrete members is discussed and the method of calculating crack width is also presented.

5.2 DEFLECTION LIMITS AS PER IS 456-2000

Deflection in the R.C. members may be divided into the following two types:

- (a) Short term deflections
- (b) Long term deflections

Short term deflections are due to elastic deformations which occur immediately after the member is loaded. But the deflections in the members goes on increasing with the life due to creep and shrinkage under sustained loads. The deflections observed in aged members is termed as long term deflections.

IS code expresses the allowable deflections in terms of span divided by an integer constant as given below [Clause 23.2 in IS 456]

- (a) Final deflections from cast level

$$\neq \frac{\text{span}}{250}$$

- (b) Final deflection due to partitions and finishes

$$\neq \frac{\text{span}}{350} \text{ or } 20 \text{ mm whichever is less}$$

5.3 THEORETICAL METHOD OF CALCULATING DEFLECTIONS

The total deflection is the sum of short term deflection and long term deflection due to sustained loads. These values can be determined theoretically as explained below:

Short Term Deflections

Short term deflection is calculated treating R.C. members as elastic members. Readers must have studied various methods of finding deflections in beams in the subjects strength of materials and structural analysis. Maximum deflections in some of the standard cases is listed in Table 5.1

Table 5.1 Maximum Deflections in Standard Cases

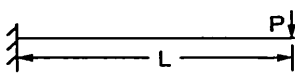
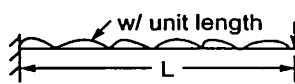
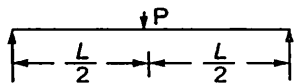
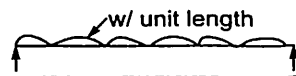
Sl. No.	Case Description	Sketch	Maximum Deflection
1.	Cantilever with load at free end		$\frac{PL^3}{3EI}$
2.	Cantilever subjected to <i>udl</i> throughout		$\frac{wL^4}{8EI}$
3.	S.S. beam with central concentrated load		$\frac{PL^3}{48EI}$
4.	S.S. beam with <i>udl</i> throughout		$\frac{5wL^4}{384EI}$

In the above cases P and w are the design (factored) loads as per the limit state of serviceability (table 2.1) and E and I are to be taken as specified below (Annex C in IS 456-2000)

$$E = E_c = \text{Short term modulus of elasticity of concrete} \\ = 5000\sqrt{f_{ck}}$$

$$I = I_{eff} = \frac{I_r}{12 - \frac{Mr}{M} \frac{z}{d} \left(1 - \frac{x}{d}\right) \frac{b_w}{b}}, \text{ but}$$

$$I_r \leq I_{eff} \leq I_{gr}$$

where,

I_{eff} = Effective moment of inertia

I_{gr} = Moment of inertia of gross section

$$= \frac{1}{12} bD^3, \text{ for rectangular section}$$

I_r = Moment of inertia of the cracked section.

Mr = Cracking moment, and

M = Maximum moment under design service loads

x = Depth of neutral axis

z = Lever arm

b_w = Breadth of the web

5.1

5.2

b = breadth of the compression flange

d = effective depth of beam

D = Overall depth of beam

Cracking moment is given by

$$M_r = \frac{f_{cr} I_{gr}}{y_t} \quad 5.3$$

Where f_{cr} = tensile strength of concrete

$$= 0.7\sqrt{f_{ck}} \quad 5.4$$

y_t = the distance of extreme tensile fibre from centroid of gross section

$$= \frac{D}{2} \quad 5.5$$

Maximum moment under design service load, are to be calculated. Readers can recollect the expressions shown in Table 5.2, which are learnt in strength of Materials/Structural Analysis Courses

Table 5.2 Maximum Moment in Standard Cases

Sl. No.	Case Description	Sketch	Maximum Deflection
1.	Cantilever with concentrated load at free end		PL
2.	Cantilever subjected to udl throughout		$\frac{wL^2}{2}$
3.	S.S. beam with central concentrated load		$\frac{PL}{4}$
4.	S.S. beam with udl throughout		$\frac{wL^2}{8}$

The moment of inertial of the cracked section I_r , is found by assuming linear stress strain diagram as explained below:

(a) **For Singly Reinforced Rectangular Section (Ref. Fig. 5.1)**

Equating moment of areas of transformed sections about the neutral axis, we get

$$\frac{bx^2}{2} = m Ast (d-x) \quad 5.6$$

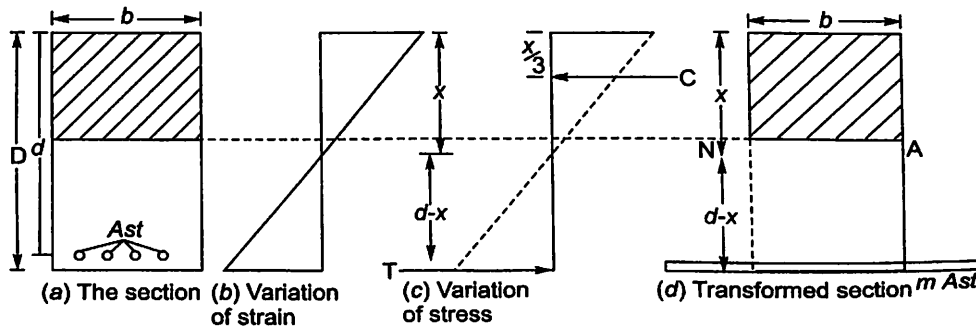

Fig. 5.1.

where x = distance of neutral axis from compression flange
 and m = short term modular ratio of steel to concrete

$$= \frac{E_s}{E_c}$$

5.7

Some of the authors have used the value of 'm' as it is used in elastic theory i.e. $m = \frac{280}{3\sqrt{\sigma_{cbc}}}$. However in Design Aid for IS 456 -1978 (SP-16), it is used as given in equation 5.8 with the meaning of E_c as given in equation 5.1. Hence the author has used the value of m as used in SP-16.

Then moment of inertia of cracked section is found by taking moment of area of transformed section about the neutral axis. Thus

$$I_r = \frac{bx^3}{3} + m Ast (d-x)^2$$

5.8

(b) For Doubly Reinforced Rectangular Section (Fig. 5.2)

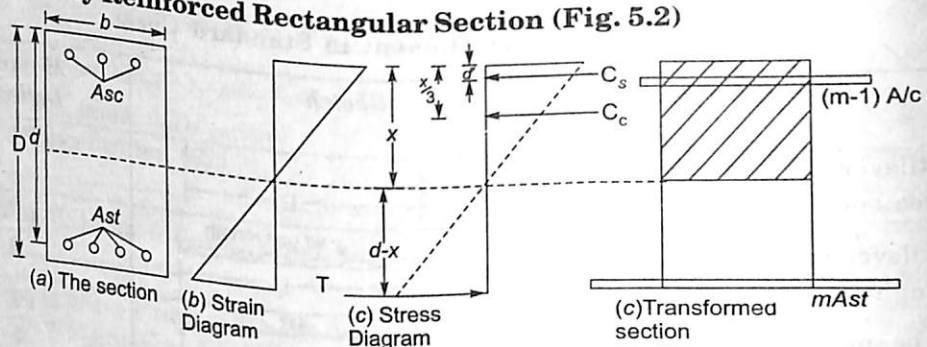

Fig. 5.2.

$m Asc$ area is split into area Asc and $(m-1) Asc$, so that the area of Asc can be taken as portion of rectangular equivalent section. Let x be depth of N-A. Then, taking moment of transformed areas about N-A, we get

$$\frac{bx^2}{2} + (m-1) Ast (x-d') = m Ast (d-x)$$

5.9

From this x can be found. Then

I_r = The moment of inertia of cracked section

$$= \frac{bx^3}{3} + (m-1) Ast (d-d')^2 + m Ast (d-x)^2$$

5.10

(c) For Singly - Reinforced Flanged Section (Ref. Fig. 5.3)

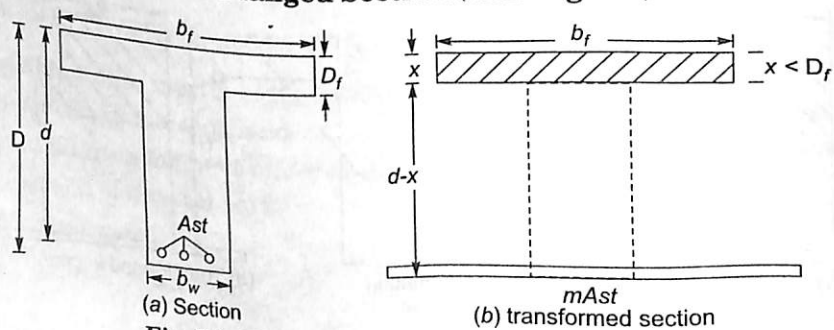

Fig. 5.3. Flanged section with N - A in flange.

(i) If N-A is in flange, the depth of N-A is obtained from,

$$b_f \frac{x^2}{2} = m Ast (d - x) \quad 5.11$$

Then

$$Ir = b_f \frac{x^3}{3} + m Ast (d - x)^2 \quad 5.12$$

(ii) If N-A is in Web (Ref. Fig. 5.4)

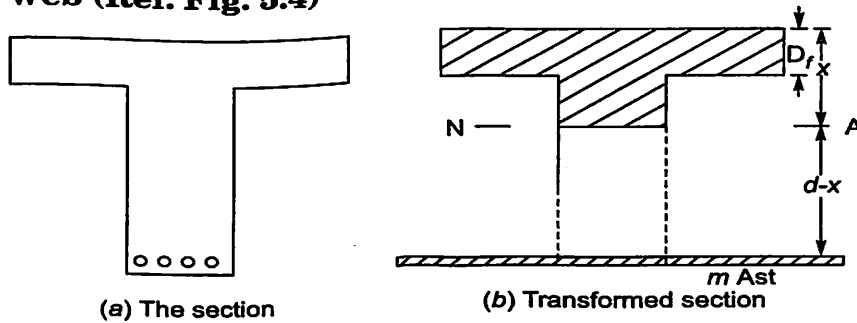

Fig. 5.4. Flanged section with N-A in webs.

Equating moment of compression area with moment of tensile area of transformed section about N-A we get,

$$b_f D_f \left(x - \frac{D_f}{2} \right) + b_w \frac{(x - D_f)^2}{2} = m Ast (d - x) \quad 5.13$$

Then,

$$Ir = \frac{1}{12} b_f D_f^3 + b_f D_f \left(x - \frac{D_f}{2} \right)^2 + b_w \frac{(x - D_f)^3}{3} \quad 5.14$$

$$= m Ast (d - x)^2 \quad 5.15$$

Example 5.1. A rectangular simply supported beam of span 5m is 300mm × 650mm in cross section and is reinforced with 3 bars of 20mm on tension side at an effective cover of 50mm. Determine the short term deflection due to an imposed working load of 20 kN/m, (excluding self wt). Assume grade of concrete M20 and grade of steel as Fe 415.

Solution.

$$\begin{aligned} b &= 300 \text{ mm} & D &= 650 \text{ mm} & \text{Cover} &= 50 \text{ mm} \\ f_{ck} &= 20 \text{ N/mm}^2 & f_y &= 415 \text{ N/mm}^2 \\ L &= 5 \text{ m,} & I \bar{L} &= 20 \text{ kN/m} \end{aligned}$$

$$Ast = 3 \times \frac{\pi}{4} \times 20^2 = 942.5 \text{ mm}^2$$

$$\text{Self weight} = 0.3 \times 0.65 \times 25 = 4.5 \text{ kN/m}$$

$$\text{Total service load} = 20 + 4.5 = 24.5 \text{ kN/m}$$

$$\begin{aligned} \therefore \text{Max bending moment at service load} &= \frac{wL^2}{8} \\ &= 24.5 \times \frac{5^2}{8} \end{aligned}$$

$$M = 76.5625 \text{ kN m}$$

$$I_{gr} = \frac{bD^3}{12} = \frac{300 \times 650^3}{12} = 6865.625 \times 10^6 \text{ mm}^4$$

$$f_{cr} = 0.7\sqrt{f_{ck}} = 0.7\sqrt{20} = 3.1305 \text{ N/mm}^2$$

$$y_t = \frac{D}{2} = \frac{650}{2} = 325 \text{ mm}$$

∴ Cracking moment

$$M_s = \frac{f_{cr} I_{gr}}{y_t} = \frac{3.1305 \times 6865.625 \times 10^6}{325}$$

$$= 66.132 \times 10^6 \text{ N mm}$$

$$E_c = 5000\sqrt{f_{ck}} = 5000\sqrt{20} = 22360.68 \text{ N/mm}^2$$

$$E_s = 2 \times 10^5 \text{ N/mm}^2$$

$$\therefore m = \frac{E_s}{E_c} = \frac{2 \times 10^5}{22360.68} = 8.944$$

Let x be depth of N-A from compression flange. Equating moment of compression area to moment of equivalent tensile area about N-A, we get

$$\frac{bx^2}{2} = m Ast (d - x)$$

$$\frac{300x^2}{2} = 8.944 \times 942.5 (600 - x)$$

$$\therefore x^2 = 56.197(600 - x)$$

$$\text{or } x^2 + 56.197x - 33718.1 = 0$$

$$\therefore x = \frac{-56.197 + \sqrt{56.197^2 + 4 \times 33718.1}}{2}$$

$$= 157.66 \text{ mm}$$

$$\therefore I_r = \frac{bx^3}{3} + m Ast (d - x)^2$$

$$= \frac{300 \times 157.66^3}{3} + 8.944 \times 942.5 (600 - 157.66)^2$$

$$= 2041.26 \times 10^6 \text{ mm}^4$$

$$I_{eff} = \frac{I_r}{1.2 - \frac{Mr}{M} \frac{z}{d} \left(1 - \frac{x}{d}\right) \frac{b_w}{b}}$$

Now,

$$\frac{b_w}{b} = 1$$

$$z = d - \frac{x}{3} = 600 - \frac{157.66}{3} = 547.47 \text{ mm}$$

$$I_{eff} = \frac{2041.26 \times 10^6}{1.2 - \frac{66.132 \times 10^6}{76.5625 \times 10^6} \times \frac{547.47}{600} \left(1 - \frac{157.66}{600}\right) \times 1}$$

$$= 3297.91 \times 10^6 \text{ mm}^4$$

But as per code,

$$I_r \leq I_{eff} \leq I_{gr}$$

$$\therefore I_{eff} = 3297.912 \times 10^6 \text{ mm}^4 \text{ is OK}$$

\therefore Maximum Deflection

$$\begin{aligned} &= \frac{5}{384} \frac{wL^4}{EI} \\ &= \frac{5}{384} \frac{24.5 \times 1000}{1000} \times (5000)^4 \\ &= 2.70 \text{ mm} \end{aligned}$$

Ans.

$$\left[\text{Note } w = 24.5 \text{ kN/m} = \frac{24.5 \times 1000}{1000} = 24.5 \text{ N/mm} \right]$$

Example 5.2. A T-beam section has the following data:

- (i) Effective width of flange = 120 mm
- (ii) Thickness of flange = 120 mm
- (iii) Width of rib = 300 mm
- (iv) Effective depth = 600 mm

Main reinforcement consist of 8 bars of 20 mm. The grade of concrete and steel used are M20 and Fe 415 respectively. Determine the short term maximum deflection if it is subjected to a total service load of 40 kN/m, when used as a simply supported beam of span 6 m.

Solution.

$$b_f = 1600 \text{ mm}$$

$$D_f = 120 \text{ mm}$$

$$b_w = 300 \text{ mm}$$

$$d = 600 \text{ mm}$$

$$A_{st} = 8 \times \frac{\pi}{4} \times 20^2 = 2513 \text{ mm}^2$$

$$f_{ck} = 20 \text{ N/mm}^2$$

$$f_y = 415 \text{ N/mm}^2$$

$$\text{Service load} = w = 40 \text{ kN/m} \quad L = 6 \text{ m}$$

\therefore Maximum bending moment at service load

$$M = \frac{wL^2}{8} = 40 \times \frac{6^2}{8} = 180 \text{ kN-m}$$

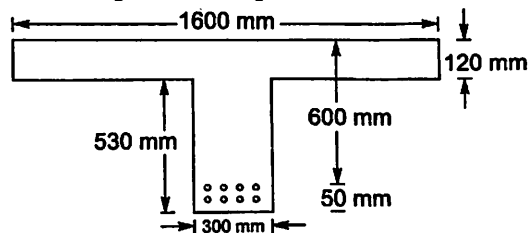

Fig. 5.5.

To find I_{gr}

Let overall depth $D = 650 \text{ mm}$, and y_c be the depth of centroid of the T-Section from compression fibre.

$$\begin{aligned} \therefore y_c &= \frac{\text{Moment of areas about topmost fibre}}{\text{Total area}} \\ &= \frac{1600 \times 120 \times 60 + (650 - 120) \times 300 \times \left(\frac{650 - 120}{2} + 120 \right)}{1600 \times 120 + (650 - 120) \times 300} \\ &= \frac{72735000}{351000} = 207.2 \text{ mm} \end{aligned}$$

$$\therefore y_t = D - y_c = 650 - 207.2 = 442.78$$

$$\begin{aligned} \therefore I_{gr} &= \frac{1}{12} \times 1600 \times 120^3 + 1600 \times 120 (207.2 - 60)^2 \\ &\quad + \frac{1}{12} \times 300 \times 530^3 + 300 \times 530 \left(\frac{530}{2} + 120 - 207.2 \right)^2 \\ &= 13138.99 \times 10^6 \text{ mm}^4 \end{aligned}$$

To find M_r

$$f_{cr} = 0.7 \sqrt{f_{ck}} = 0.7 \sqrt{20} = 3.1305 \text{ N/mm}^2$$

$$y_t = 442.78 \text{ mm}$$

\therefore Cracking moment

$$\begin{aligned} M_r &= \frac{f_{cr} I_{gr}}{y_t} = \frac{3.1305 \times 13138.99 \times 10^6}{442.78} \\ &= 92.894 \times 10^6 \text{ N-mm} = 92.894 \text{ kN-m} \end{aligned}$$

Modular Ratio:

$$E_c = 5000 \sqrt{f_{ck}} = 5000 \sqrt{20} = 22360.68 \text{ N/mm}^2$$

$$E_s = 2 \times 10^5 \text{ N/mm}^2$$

$$\therefore m = \frac{E_s}{E_c} = \frac{2 \times 10^5}{22360.68} = 8.944$$

Let x be the depth of Neutral axis of cracked section from compression flange. Assuming it is within the flange,

$$\frac{b_f x^2}{2} = m A_{st} (d - x)$$

$$1600 \frac{x^2}{2} = 8.944 \times 2513 (600 - x)$$

$$x^2 = 28.095 (600 - x)$$

$$\text{i.e., } x^2 + 28.095x - 16857.2 = 0$$

$$x = \frac{-28.095 + \sqrt{28.095^2 + 4 \times 16857.2}}{2}$$

$$= 116.55 \text{ mm} < 120 \text{ mm}$$

\therefore Assumption that x is within the flange is correct. Hence $x = 116.55 \text{ mm}$

$$\begin{aligned} \therefore I_r &= \frac{b_f x^3}{3} + m Ast(d-x)^2 \\ &= \frac{1600 \times 116.55^3}{3} + 8.944 \times 2513 (600 - 116.55)^2 \\ &= 6097.617 \times 10^6 \text{ mm}^4 \end{aligned}$$

$$\therefore I_{eff} = \frac{I_r}{1.2 - \frac{Mr}{M} \frac{z}{d} \left(1 - \frac{x}{d}\right) \frac{b_w}{b}}$$

Now, $\frac{b_w}{b} = \frac{b_w}{b_f} = \frac{300}{1600}$

$$z = d - \frac{x}{3} = 600 - \frac{116.55}{3} = 561.15 \text{ mm}$$

$$I_{eff} = \frac{6097.617 \times 10^6}{1.2 - \frac{92.894}{180} \times \frac{561.15}{600} \left(1 - \frac{116.55}{600}\right) \frac{300}{1600}} = 5410.1 \times 10^6 \text{ mm}^4$$

$$I_r \leq I_{eff} \leq I_{gr}$$

$$\therefore I_{eff} = I_r = 6097.617 \times 10^6 \text{ mm}^4$$

$$\therefore \text{Max Deflection} = \frac{5}{384} \frac{wL^4}{EI} = \frac{5}{384} \frac{wL^4}{E_c I_{eff}}$$

$$= \frac{5}{384} \times \frac{40 \times \frac{1000}{1000} \times (6000)^4}{22360.68 \times 6097.617 \times 10^6} = 4.95 \text{ mm}$$

Example 5.3 A cantilever beam of span 3 m has a cross section of 250 mm × 500 mm. It is reinforced with 4 bars of 20 mm diameter on tension side and 2 bars of 20 mm on compression side, with effective cover of 50 mm on both sides. Determine the deflection at free end, if it is subjected to a total service load (including self weight) of 30 kN/m. Grades of concrete and steel used are M 25 and Fe 415.

Solution.

A cantilever has tension on top side and compression on bottom side for vertically downward loads. However for the convenience of calculating deflection, it is shown with tensile reinforcements at bottom and compression reinforcements at top in Fig. 5.6

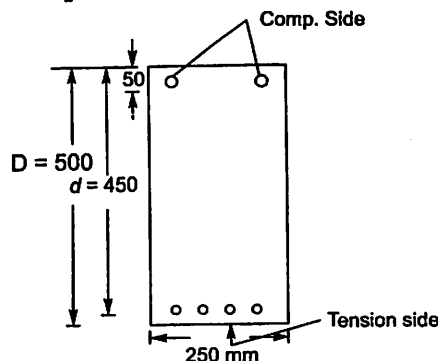

Fig. 5.6. Cross section of cantilever shown upside down for convenience of calculating.

$$b = b_w = 250 \text{ mm}$$

$$D = 500 \text{ mm}$$

$$A_{st} = 4 \times \frac{\pi}{4} \times 20^2 = 1256 \text{ mm}^2$$

$$f_{ck} = 25 \text{ N/mm}^2$$

$$\text{Total service load} = 20 \text{ kN/m.}$$

\therefore Maximum bending moment at service load

$$M = \frac{wL^2}{2} = \frac{20 \times 3^2}{2} = 90 \text{ kN-m}$$

$$I_{gr} = \frac{bD^3}{12} = \frac{250 \times 500^3}{12} = 2604.167 \times 10^6 \text{ mm}^4$$

To find M_r ,

$$f_{cr} = 0.7\sqrt{f_{ck}} = 0.7\sqrt{25} = 3.5 \text{ N/mm}^2$$

$$y_t = \frac{500}{2} = 250 \text{ mm}$$

$$M_r = \frac{f_{cr} I_{gr}}{y_t} = \frac{3.5 \times 2604.167 \times 10^6}{250}$$

$$= 36.458 \times 10^6 \text{ N-mm}$$

$$= 36.458 \text{ kN-m}$$

Modular Ratio:

$$E_c = 5000\sqrt{f_{ck}} = 5000\sqrt{25} = 25000 \text{ N/mm}^2$$

$$E_s = 2 \times 10^5 \text{ N/mm}^2$$

\therefore

$$m = \frac{2 \times 10^5}{25000} = 8$$

Let x be the depth of neutral axis of the cracked section from compression flange. Then taking moment of transformed section about N-A we get,

$$\frac{bx^2}{2} + (m-1)Asc(x-d') = m A_{st} \left(d - \frac{x}{3} \right)$$

$$\text{i.e., } \frac{250x^2}{2} + (8-1)628(x-50) = 8 \times 1256 \left(450 - \frac{x}{3} \right)$$

$$x^2 + 35.168(x-50) = 80.384 \left(450 - \frac{x}{3} \right)$$

$$x^2 + 61.963x - 37931.2 = 0$$

$$x = \frac{-61.963 + \sqrt{61.963^2 + 4 \times 37931.2}}{2}$$

$$= 166.23 \text{ mm}$$

$$\begin{aligned} \therefore I_r &= \frac{bx^3}{3} + (m-1)Asc(d-d')^2 + mAst(d-x)^2 \\ &= \frac{230 \times 166.23^3}{3} + (8-1)628(450-50)^2 \\ &\quad + 8 \times 1256(450-166.23)^2 \\ &= 1895.257 \times 10^6 \text{ mm}^4 \end{aligned}$$

$$I_{eff} = \frac{I_r}{1.2 - \frac{Mr}{M} \frac{z}{d} \left(1 - \frac{x}{d}\right) \frac{b_w}{b}}$$

Now,

$$\frac{b_w}{b_f} = 1 \quad z = d - \frac{x}{3} = 450 - \frac{166.23}{3} = 394.59 \text{ mm}$$

$$Mr = 36.458 \times 10^6 \text{ N-mm}$$

$$M = 90 \times 10^6 \text{ N-mm}$$

$$\begin{aligned} \therefore I_{eff} &= \frac{1895.257 \times 10^6}{1.2 - \frac{36.458}{90} \times \frac{394.59}{450} \left(1 - \frac{166.23}{450}\right) \times 1} \\ &= 1941.85 \times 10^6 \text{ mm}^4 \end{aligned}$$

But $I_r \leq I_{eff} \leq I_{gr}$

$$\therefore I_{eff} = 1941.85 \times 10^6$$

\therefore Deflection at free end of cantilever

$$\begin{aligned} &= \frac{wL^4}{8EI} = \frac{wL^4}{8E_c I_{eff}} \\ &= \frac{20 \times (3000)^4}{8 \times 25000 \times 1941.85 \times 10^6} \end{aligned}$$

$$\Delta_{max} = 4.17 \text{ mm}$$

Ans.

Short Term Deflections In Continuous Beams:

To find deflections in continuous beams, the values of I_r , I_{gr} and Mr are to be modified, since they are not same at supports and mid span. The suggested modification by IS 456 is as given below:

$$X_e = k_1 \left[\frac{x_1 + x_2}{2} \right] + (1 - k_1)x_0 \quad 5.15$$

where X_e = modified value of x

x_1, x_2 = values of x at the supports

x_0 = value of x at midspan

k_1 = coefficient given in table 5.3

x = value of I_r , I_{gr} or Mr as appropriate

Table 5.3 Values at Coefficient, k_1

k_2	0.5 or less	0.6	0.7	0.8	0.9	1.0	1.1	1.2	1.3	1.4
k_1	0	0.03	0.08	0.16	0.30	0.50	0.73	0.91	0.97	1.0

Where k_2 is given by

$$k_2 = \frac{M_1 + M_2}{M_{F1} + M_{F2}}$$

where M_1, M_2 = Support moments, and

M_{F1}, M_{F2} = Fixed end moments

Long-Term Deflections:

It mainly consists of deflection due to shrinkage and deflection due to creep. IS 456 procedure to assess these deflections is given below:

$$\alpha_{cs} = k_3 \Psi_{cs} l^2 \quad 5.16$$

where, k_3 is a constant depending upon the support conditions

= 0.5 for cantilevers

= 0.125 for simply supported beams

= 0.086 for members continuous at one end

= 0.063 for fully continuous members

Ψ_{cs} is shrinkage curvature to be calculated based on shrinkage strains ϵ_{cs} . In the absence of test data, IS code permits taking $\epsilon_{cs} = 0.0003$ [clause 6.2.4].

Shrinkage curvature is given by the expression,

$$\Psi_{cs} = k_4 \frac{\epsilon_{cs}}{D} \quad 5.17$$

where D is total depth of the section and

$$k_4 = 0.72 \frac{p_t - p_c}{\sqrt{p_t}} \leq 0.1 \text{ for } 0.25 \leq p_t - p_c < 1.0,$$

and

$$= 0.65 \frac{p_t - p_c}{\sqrt{p_t}} \leq 0.1 f_{ck} \text{ for } p_t - p_c \geq 1.0$$

where p_t - percentage of tensile reinforcement

and p_c - percentage of compression reinforcement

Deflection Due to Creep

The creep deflection depends only upon the permanent loads. It may be calculated from the following equations:

$$a_{cc}(\text{perm}) = a_{i, cc}(\text{perm}) - a_i(\text{perm}) \quad 5.18$$

where $a_{cc}(\text{perm})$ = creep deflection due to permanent loads

$a_{i, cc}(\text{perm})$ = Initial plus creep deflection due to permanent loads obtained using an elastic analysis with an effective modulus of elasticity E_{ce} .

$$E_{ce} = \frac{Ec}{1 + \theta}, \theta \text{ being the creep coefficient (Ref. Art. 1.2) and}$$

a_i (perm) = Short term deflection due to permanent load using E_c

Example 5.4. A rectangular simply supported beam of span 5m is 300mm × 650mm in cross section. It carries a total load of 30 kN/m over its entire span, out of which 10 kN/m is the live load. The beam is reinforced with 3 bars of 20mm on tension side at an effective cover of 50mm. Calculate the deflection at central span due to shrinkage and creep, if

(a) Ultimate shrinkage strain = 0.0003

(b) Creep coefficient = 1.6

Concrete mix of grade M20 and steel of Fe 415 are used.

Solution.

$$\text{Span } L = 5 \text{ m, } b = 300 \text{ mm}$$

$$\text{Effective cover} = 50 \text{ mm}$$

$$D = 650 \text{ mm}$$

$$d = 650 - 50 = 600 \text{ mm}$$

$$A_{st} = 3 \times \frac{\pi}{4} \times 20^2 = 942.5 \text{ mm}^2$$

$$p_t = \frac{942.5}{600 \times 300} \times 100 = 0.5236$$

Singly reinforced. Hence $A_{sc} = 0$ i.e. $p_c = 0$

Total load (includes live load, dead load, self weight, weight of partitions etc.) = 30 kN/m

$$\text{Live load} = 10 \text{ kN/m}$$

(a) **Deflection Due to Shrinkage**

It is given by

$$a_{cs} = k_3 \Psi_{cs} L^2$$

since it is simply supported beam, $k_3 = 0.125$

$$\epsilon_{cs} = 0.0003,$$

$$D = 650 \text{ mm}$$

$$p_t - p_c = 0.5236 \text{ which is between } 0.25 \text{ and } 1$$

Hence

$$k_4 = 0.72 \frac{p_t - p_c}{\sqrt{p_t}} = \frac{0.72 \times 0.5236}{\sqrt{0.5236}} = 0.5210$$

$$\therefore \Psi_{cs} = k_4 \frac{\epsilon_{cs}}{D} = 0.5210 \times \frac{0.0003}{650} = 2.4046 \times 10^{-7}$$

$$\therefore a_{cs} = 0.125 \times 2.4046 \times 10^{-7} \times (5000)^2 = 3.132 \text{ mm.}$$

(b) **Deflection Due to Creep**

$$\text{Permanent load} = \text{Total load} - \text{live load} = 30 - 10 = 20 \text{ kN/m}$$

Due to permanent loads, maximum bending moment at service loads,

$$m = \frac{wL^2}{8} = \frac{20 \times 5^2}{8} = 62.5 \text{ kN-m.}$$

$$I_{gr} = \frac{bD^3}{12} = \frac{300 \times 650^3}{12} = 6865.625 \times 10^6 \text{ mm}^4$$

$$f_{cr} = 0.7 \sqrt{f_{ck}} = 0.7 \sqrt{20} = 3.1305 \text{ N/mm}^2$$

$$y_t = \frac{D}{2} = \frac{650}{2} = 325 \text{ mm}$$

$$\therefore \text{Cracking moment } M_r = \frac{f_{cr} I_{gr}}{y_t}$$

$$= \frac{31309 \times 6865.625 \times 10^6}{325}$$

$$= 66.132 \times 10^6 \text{ N-mm}$$

$$E_c = 5000 \sqrt{f_{ck}} = 5000 \sqrt{20} = 22360.68 \text{ N/mm}^2$$

$$\therefore E_{ce} = \frac{E_c}{1 + \theta} = \frac{E_c}{1 + 1.6} = \frac{22360.68}{2.6} = 8600.26 \text{ N/mm}^2$$

$$\therefore E_s = 2 \times 10^5 \text{ N/mm}^2$$

$$\therefore m = \frac{E_s}{E_{ce}} = \frac{2 \times 10^5}{8600.26} = 23.255$$

\therefore Depth of neutral axis x is given by

$$\frac{bx^2}{2} = m Ast (d-x)$$

$$300 \frac{x^2}{2} = 23.255 \times 942.5 (600 - x)$$

$$\therefore x^2 = 146.12(600 - x)$$

$$x^2 + 146.12x - 87671.75 = 0$$

$$\therefore x = \frac{-146.12 + \sqrt{(146.12)^2 + 4 \times 87671.35}}{2}$$

$$= 231.91 \text{ mm}$$

$$\therefore I_r = \frac{bx^3}{3} + m Ast(d-x)^2$$

$$= \frac{300 \times 321.91^3}{3} + 23.255 \times 942.5 (600 - 231.91)^2$$

$$= 4216.917 \times 10^6 \text{ mm}^4$$

$$I_{eff} = \frac{I_r}{12 - \frac{Mr}{M} \frac{z}{d} \left(1 - \frac{x}{d}\right) \frac{b_w}{b}}$$

$$\frac{b_w}{b} = 1 \quad z = d - \frac{x}{3} = 600 - \frac{231.91}{3} = 522.697$$

$$\therefore I_{eff} = \frac{4216.917 \times 10^6}{12 - \frac{66.132 \times 10^6}{62.5 \times 10^6} \times \frac{522.697}{600} \left(1 - \frac{231.91}{600}\right) \times 1}$$

$$= 6646.05 \times 10^6 \text{ mm}^4$$

As per IS code,

$$I_r \leq I_{eff} \leq I_{gr}$$

$$\therefore I_{eff} = 6646.05 \times 10^6 \text{ is O.K.}$$

\(\therefore\) Initial plus creep deflection due to permanent loads

$$w = 20 \text{ kN/m} = \frac{20 \times 1000}{1000} = 20 \text{ N/mm}$$

$$\begin{aligned} a_{icc} &= (\text{Perm}) = \frac{5}{384} \times \frac{wL^4}{EI} = \frac{5}{384} \times \frac{20 \times (5000)^4}{8600.26 \times 6646.06 \times 10^6} \\ &= 2.85 \text{ mm} \end{aligned}$$

Short Term Deflection Due to Permanent Loads:

Noting that the beam is same as in exercise problem 5.1, we have

$$E_c = 22360.68$$

$$x = 157.66$$

$$z = 600 - \frac{117.66}{3} = 547.47 \text{ mm}$$

$$I_r = 2041.261 \times 10^6$$

$$\begin{aligned} I_{eff} &= \frac{2041.261 \times 10^6}{12 - \frac{66.132 \times 10^6}{62.5 \times 10^6} \times \frac{547.47}{600} \left(1 - \frac{157.66}{600}\right) \times 1} \\ &= 4181.03 \times 10^6 \end{aligned}$$

which is more than I_r and less than I_{gr} .

$$\text{Hence } I_{eff} = 4181.64 \times 10^6 \text{ mm}^4$$

\(\therefore\) Short term deflection due to permanent loads

$$\begin{aligned} &= \frac{5}{384} \times 20 \times \frac{(5000)^4}{22360.68 \times 4181.03 \times 10^6} \\ &= 1.741 \text{ mm} \end{aligned}$$

\(\therefore\) Deflection due to creep only

$$= 2.85 - 1.741$$

$$= 1.11 \text{ mm}$$

Ans.

5.4 ALTERNATE METHOD OF ENSURING LIMIT STATE REQUIREMENTS OF DEFLECTION

IS 456 gives simple guide lines to keep deflection of beams and slabs within the safe limits so that appearance and efficiency of the structure or finishes or partitions are not adversely affected. This alternate method of checking deflection limit is based on ensuring span to effective depth ratio within a specified limit as given below:

- (a) Basic values of span to effective ratio of different flexural members (beams, slabs etc) for spans upto 10m shall not exceed:

Cantilevers	7
Simply supported	20
Continuous	26

- (b) For spans above 10 m, the values in (a) may be multiplied by $\frac{10}{span}$ in metres, except for cantilevers in which case deflection calculations should be made.
- (c) Depending upon the area and the stress in tensile reinforcement, the values in (a) or (b) shall be modified by multiplying them with factor F_1 obtained as per Fig. 5.7 (Ref. Fig. 4 in IS 456).

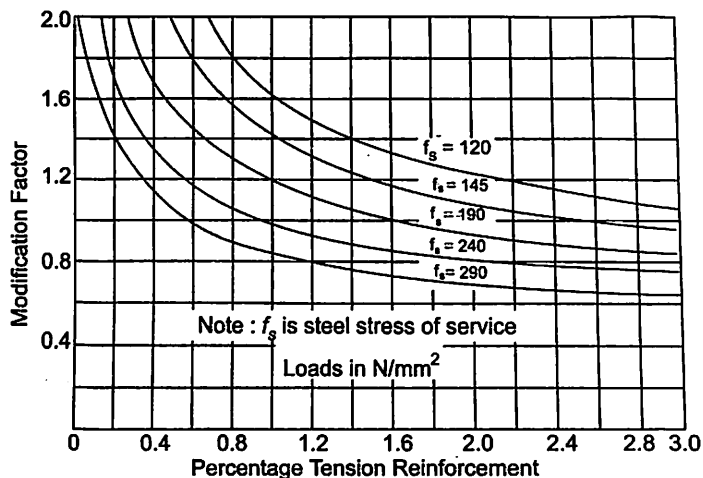

Fig. 5.7 Modification factor for tension reinforcement (Fig. 4 in IS 456 – 2000)

- (d) Depending upon the area of compression reinforcement, the value of span to depth ratio be further modified by multiplying with factor F_2 obtained as per Fig. 5.8 (Fig. 5 in IS 456).

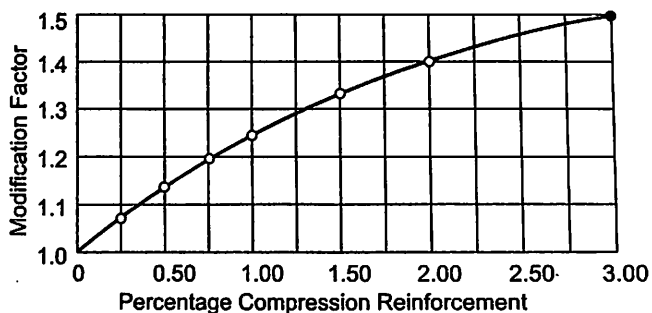

Fig 5.8. Modification factor for compression reinforcement (Fig. 5 in IS 546 – 2000)

- (e) For flanged beams, the values of (a) or (b) are to be modified as per Fig. 5.9 (Fig. 6 in IS 456) and the percentage reinforcement used in finding F_1 and F_2 should be based on area of section equal to $b_f d$.

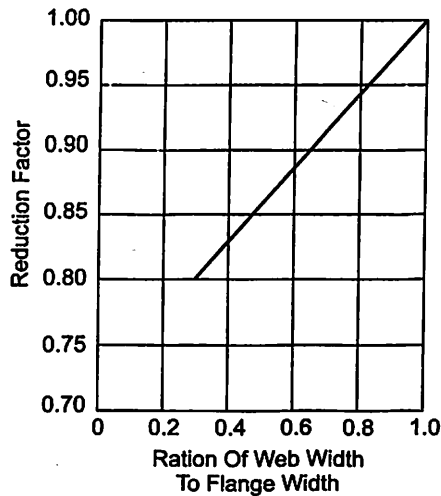

Fig. 5.9. Reduction Factors for ratios of span to effective depth for flanged beams. (Fig. 6 in IS 456) Ratio of web width to flange width.

Hence the final requirement of span to effective depth ratio is

$$\frac{\text{span}}{d} \leq F_1 F_2 F_3 \text{ (basic } \frac{\text{span}}{d} \text{ permitted)} \quad 5.18$$

Example 5.5. A rectangular beam of size 300 mm × 600 mm is reinforced with 6 bars of 20 mm diameters on tension side and 6 bars of 16 mm diameter on compression side with Fe 415 steel. The effective cover on both sides is 50 mm and the effective span of the simply supported beam is 7.5 m. Check whether depth provided is sufficient from the deflection consideration. Assume, exactly the required amount of steel is provided.

Solution.

The cross section of the beam is as shown in Fig. 5.10. In this beam,

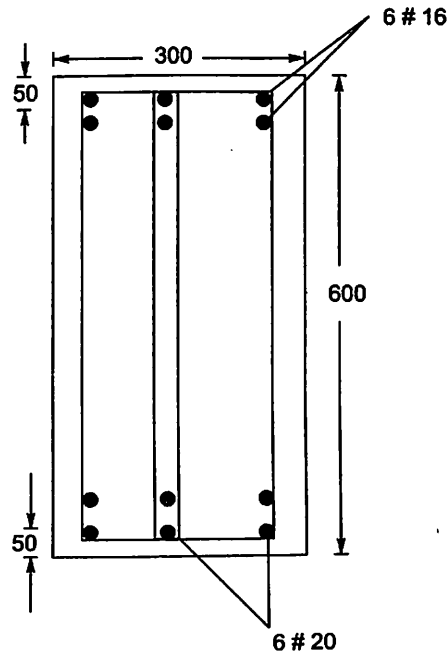

Fig. 5.10

$$D = 600 - 50 = 550 \text{ mm} \quad \text{and } h = 300 \text{ mm}$$

$$A_{st} = 1885 \text{ mm}^2 \quad A_{sc} = 1206 \text{ mm}^2$$

$$\text{Span} = 7.5 \text{ m}$$

The beam is simply supported. Hence basic span to deflection ratio permitted is = 20

The steel used is Fe415 and the amount of steel provided is exactly equal to the amount of steel required.

$$f_s = 0.58 \times 415 \times 1 \quad (\text{Ref. Fig 5.9})$$

$$= 240.1 \text{ N/mm}^2$$

$$\% \text{ Tension reinforcement} = \frac{1885 \times 100}{300 \times 550} = 1.142$$

∴ From Fig. 5.7 (IS Fig. 4), modification factor for tensile steel provided

$$F_1 = 0.98$$

% of compression steel provided

$$= \frac{1206}{300 \times 550} \times 100 = 0.731$$

∴ Modification factor for compression steel as per Fig. 5.8 (IS Fig. 5) is

$$F_2 = 1.2$$

Since it is rectangular beam, ratio of web width to flange width is 1 and hence $F_3 = 1$

$$\text{Limiting value of } \frac{\text{span}}{d} = F_1 F_2 F_3 \times \text{basic ratio}$$

$$= 0.98 \times 1.2 \times 1 \times 20$$

$$= 23.52$$

$$\frac{\text{span}}{d} \text{ provided} = \frac{7500}{550} = 13.636 M < 23.52$$

Hence the depth provided is sufficient from the consideration of deflection.

Example 5.6. Check whether the depth provided for T-beam in example 3.5 is sufficient from the consideration of deflection.

Solution.

The cross section of this beam is shown in Fig. 5.11

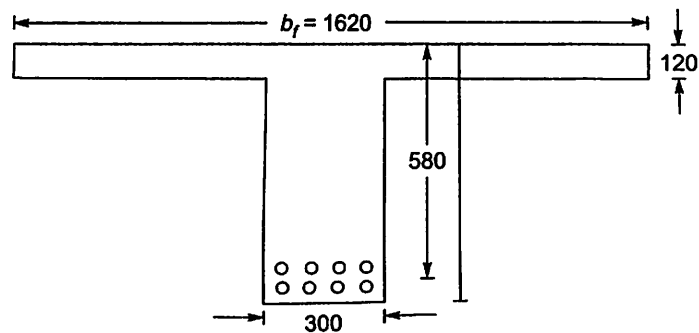

Fig. 5.11.

In this problem,

$D_f = 120 \text{ mm}$
 $b_w = 300 \text{ mm}$
 $A_{st} = 2513 \text{ mm}^2$
 Steel used is Fe 415

$b_f = 1620 \text{ mm}$
 $d = 580 \text{ mm}$
 $L = 3.6 \text{ m}$, simply supported

Since it is simply supported beam with span 3.6m basic value of $\frac{\text{span}}{d} = 20$

Assuming area of cross section of steel required is exactly equal to area of cross section of steel provided

$$f_s = 0.58 f_y \times 1 = 240.1 \text{ N/mm}^2$$

\therefore Percentage of tension reinforcement based on area of flange

$$= \frac{2513}{1620 \times 580} \times 100 = 0.267$$

Modification factor for tensile reinforcement

$$F_1 = 1.55$$

There is no compression steel *i.e.* $p_c = 0$

$$\therefore F_2 = 1.0$$

The ratio of web width to flange width

$$= \frac{300}{1620} = 0.185$$

$$\therefore \text{From Fig 5.9} \quad F_3 = 0.8$$

\therefore Permissible ratio of effective span to depth

$$\begin{aligned}
 &= F_1 F_2 F_3 \times \text{basic ratio} \\
 &= 1.55 \times 1 \times 0.8 \times 20 = 24.8
 \end{aligned}$$

Ratio of effective span to depth provided

$$= \frac{3600}{580} = 6.2 < 21.92. \quad \text{Hence O.K.}$$

5.5 CRACKING IN STRUCTURAL MEMBERS

In Art 2.2, while explaining the limit state of cracking, the adverse effects of cracking have been listed and it was pointed out that tensile cracks in reinforced concrete are unavoidable. The following acceptable limits of crack widths under service load conditions have been specified by IS 456-2000, keeping in mind that cracking should not affect the appearance or durability of the structure [clause 35.3.2, page 67]

- 0.3mm in members where cracking is not harmful on the durability of the structure
- 0.2mm in members continuously exposed to moisture or in contact with soil or water
- 0.1mm in members exposed to aggressive environment such as the 'severe' category given in Appendix A.

Cracks due to bending in a compression member subject to a design axial load greater than $0.2f_{ck} A_c$, where f_{ck} is the characteristic strength of concrete and A_c is the area of the gross section of the member need not be checked. According to IS 456 (clause 43), a compressive member subjected to lesser load than $0.2 f_{ck} A_c$ and the flexural members may be treated as

sufficient to central cracking, if the following spacing requirements of reinforcement are met [clause 26.3.2 of IS 456]:

- (a) The horizontal distance s_1 (Fig. 5.12), between two parallel main reinforcing bars shall not be less than the greatest of the following
- (i) the diameter of the bar, if the diameters are equal

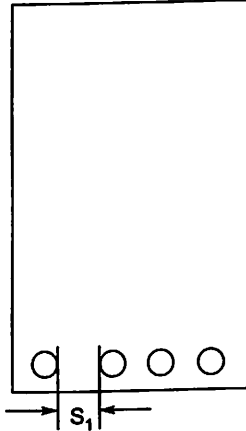

Fig. 5.12. Horizontal spacing Between two Bars.

- (ii) the diameter of the larger bar, if the diameters are unequal and
 - (iii) 5 mm more than the nominal maximum size of coarse aggregate.
- (b) If needle vibrators are used, the horizontal distance between bars of a group may be reduced to two-thirds the nominal maximum size of the coarse aggregates, provided that sufficient space is left between groups of bars to enable the vibrator to be immersed.
- (c) Where there are two or more rows of bars, the bars shall be vertically in line and the minimum vertical distance between the bars s_2 (Fig. 5.13) shall be 15 mm, two-thirds the nominal maximum size of aggregates or the maximum size of bars, whichever is greater. IS 456 specifies that if the above requirements of detailing cannot be met due to some unavoidable reasons, the crackle width should be calculated and checked.

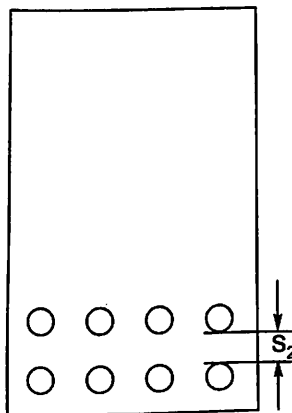

Fig. 5.13. Vertical spacing Between two Rows of Bars.

5.6 CRACK WIDTH CALCULATION

Many researchers have worked for several years to establish theoretical expressions for crack width calculation. Different formulae's have been accepted as satisfactory by different codes. IS 456 – 2000 has accepted the following formula for crack width calculations (Annex F in IS 456)

$$W_{cr} = \frac{3a_{cr}\epsilon_m}{1 + \frac{2(a_{cr} - c_{min})}{h - x}} \quad 5.20$$

where a_{cr} = distance of the point under consideration from the surface of nearest longitudinal bar.

c_{min} = minimum cover to the longitudinal bar.

ϵ_m = average strain in longitudinal steel

h = overall depth of the section

x = depth of neutral axis from the compression, calculated considering both steel and concrete as fully elastic.

For the above calculation modulus of elasticity in steel and concrete are to be taken as given below:

$$E_s = 2 \times 10^5 \text{ N/mm}^2 = 200 \text{ kN/mm}^2$$

and

$$E_c = 5000 \sqrt{f_{ck}}$$

These terms a_{cr} and c_{min} are illustrated in Fig. 5.14

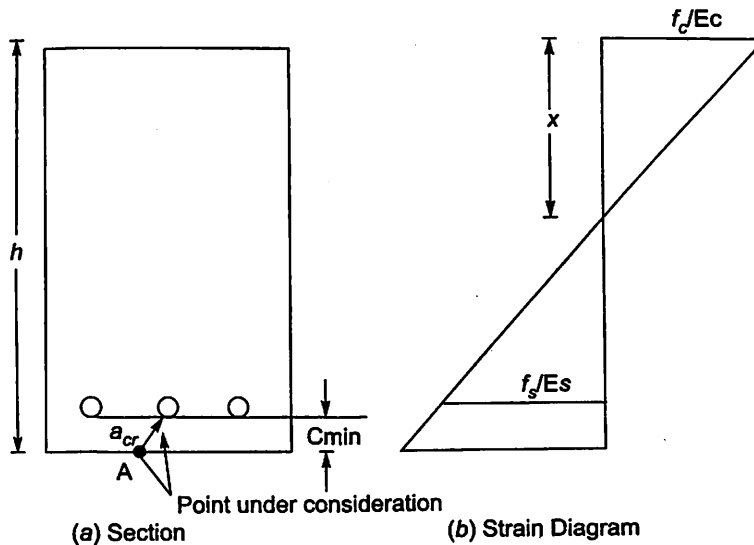

Fig. 5.14. Parameters for calculating crack width at A.

In the equation 5.20, the term ϵ_m may be calculated from the following formula

$$\epsilon_m = \epsilon_1 - \frac{b(h-x)(a-x)}{3E_s A_s (d-x)} \quad 5.21$$

where ϵ_1 = strain at the level considered which may be calculated using transformed section in the elastic state, and the second term is to consider the effect of stiffening of the concrete in tension zone.

In this expression.

b = width of the section at the centroid of the tensile steel

a = distance from the compression face to the point at which crack width is being calculated.

d = effective depth

A_s = area of tension reinforcement

To find long term crack width, the second term in equation 5.21 i.e. the reduction factor to account for stiffening due to concrete, may be taken as $0.55 \frac{b(h-x)(a-x)}{3E_s A_s (d-x)}$

Example 5.7 A reinforced concrete beam of size 250mm x 500mm is provided with 4 bars of 20 mm with an effective cover of 40mm as shown in Fig 5.15. The section has to resist a bending moment of 60kN-m. Determine the crack width at point A which is the mid point of tension edge and at point B, which is on tension edge just below bar (as shown in Figure). Take grade of concrete mix M20 and grade of steel as Fe 415.

Solution.

$$b = 250 \text{ mm} \quad D = h = 500 \text{ mm} \quad d = 500 - 40 = 460 \text{ mm}$$

$$A_{st} = 4 \times \frac{\pi}{4} \times 20^2 = 1256 \text{ mm}^2$$

$$E_s = 2 \times 10^5 \text{ N/mm}^2 \quad E_c = 5000\sqrt{20} = 22360.68 \text{ N/mm}^2$$

∴ During service condition (stress variation linear), depth of neutral axis is given by

$$\frac{bx^2}{2} = m A_{st} (d-x)$$

$$\frac{250x^2}{2} = 8.944 \times 1256 (460 - x)$$

$$x^2 = 89.872 (460 - x)$$

$$\text{i.e., } x^2 + 89.872x - 43141 = 0$$

$$x = \frac{-89.872 + \sqrt{89.872^2 + 4 \times 43141}}{2} = 163.30 \text{ mm}$$

∴ The moment of inertia of transformed section

$$I_r = \frac{bx^3}{3} + m A_{st} (d-x)^2$$

$$= \frac{250(163.3)^3}{3} + 8.944 \times 1256 (460 - 163.3)^2 = 1351.77 \times 10^6 \text{ mm}^4$$

∴ Stress at the level of A = $\frac{M}{I} \times y$

$$= \frac{60 \times 10^6}{1351.77 \times 10^6} \times (500 - 163.3) = 14.945 \text{ N/mm}^2$$

$$\therefore \text{Strain at A, } \epsilon_1 = \frac{f}{E_c} = \frac{14.945}{22360.68} = 6.6835 \times 10^{-4}$$

$$\therefore \epsilon_m = \epsilon_1 - \frac{b(h-x)(a-x)}{3E_s A_s (d-x)}$$

Now

$$\begin{aligned} h &= a = 500 \text{ mm} \\ x &= 163.3 \text{ mm} \\ A_s &= A_{st} = 1256 \text{ mm}^2 \\ E_s &= 2 \times 10^5 \text{ N/mm}^2 \\ b &= 250 \text{ mm} \\ d &= 460 \text{ mm} \end{aligned}$$

$$\therefore \epsilon_m = 6.6835 \times 10^{-4} - \frac{250(500 - 163.3)(500 - 163.3)}{3 \times 2 \times 10^5 \times 1256(460 - 163.3)} = 5.416 \times 10^{-4}$$

\therefore Crack width

$$w_{cr} = \frac{3a_{cr}\epsilon_m}{1 + \frac{2(a_{cr} - c_{\min})}{(h-x)}}$$

Now

$$c_{\min} = 40 - 10 = 30 \text{ mm}$$

For point A ,

$$a_{cr} = \sqrt{30^2 + \left(\frac{35}{2}\right)^2} = 34.73 \text{ mm}$$

$\therefore w_{cr}$ at

$$A = \frac{3 \times 34.73 \times 5.416 \times 10^{-4}}{1 + \frac{2(34.73 - 30)}{500 - 163.3}} = 0.055 \text{ mm} \quad \text{Ans.}$$

For point B,

$$a_{cr} = 30 \text{ mm}$$

$\therefore w_{cr}$ at

$$\begin{aligned} B &= \frac{3 \times 30 \times 5.416 \times 10^{-4}}{1 + \frac{2(30 - 30)}{500 - 163.3}} = 3 \times 30 \times 5.416 \times 10^{-4} \\ &= 0.049 \text{ mm} \quad \text{Ans.} \end{aligned}$$

Example 5.8 Flange of a T-beam R.C. section is $1200 \times 130\text{mm}$, width of rib 300 mm and effective depth is 550 mm . It is reinforced with 8 bars of 20 mm provided in two rows with effective cover of 50 mm . Determine crack width at A (Ref. Fig. 5.16) which is just below the bar, when the beam is subjected to a moment of 120 kN-m . Concrete mix used is M25 and steel grade is Fe 415.

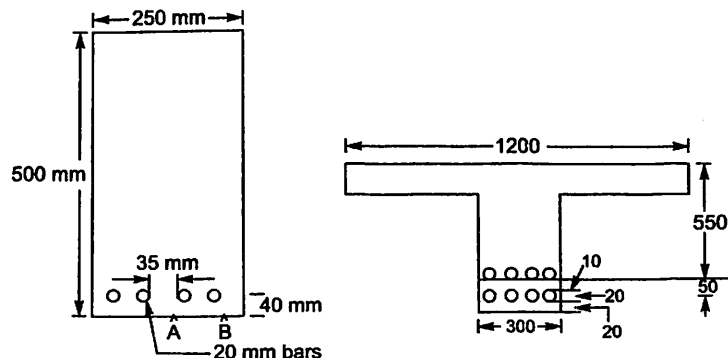

Fig. 5.15.

Solution.

$$b_f = 1200 \text{ mm}$$

$$d = 550 \text{ mm}$$

$$D_f = 130 \text{ mm}$$

$$h = D = 550 + 50 = 600 \text{ mm}$$

$$A_{st} = 8 \times \frac{\pi}{4} (20)^2 = 2513 \text{ mm}^2$$

$$E_s = 2 \times 10^5 \text{ N/mm}^2$$

$$E_c = 5000\sqrt{25} = 25000 \text{ N/mm}^2$$

$$m = \frac{E_s}{E_c} = \frac{2 \times 10^5}{25000} = 8$$

During service condition depth of neutral axis is calculated assuming linear variation of stress. Assuming neutral axis is within the flange,

$$\frac{bx^2}{2} = m A_{st} (d-x)$$

$$1200 \frac{x^2}{2} = 8 \times 2513 (550 - x)$$

$$x^2 = 33.506x (550 - x)$$

$$x^2 + 33.506x - 18428.7 = 0$$

$$x = \frac{-33.506 + \sqrt{33.506^2 + 4 \times 18428.7}}{2}$$

$$= 120.03 \text{ mm} < 130 \text{ mm}$$

Hence assumption that the neutral axis is within the flange is correct i.e. $x = 120.03 \text{ mm}$.

∴ Moment of inertia of transformed section

$$I_r = \frac{b_f x^3}{3} + m A_{st} (d-x)^2$$

$$= \frac{1200 \times 120.03^3}{3} + 8 \times 2513 (550 - 120.03)^2$$

$$= 4408.43 \times 10^6 \text{ mm}^4$$

∴ Stress at the level of point A

$$f_c = \frac{M}{I_r} y = \frac{120 \times 10^6}{4408.43 \times 10^6} \times (600 - 120.03) = 13.066 \text{ N/mm}^2$$

∴ Strain at A in cracked section

$$\epsilon_1 = \frac{f_c}{E_c} = \frac{13.066}{25000} = 5.226 \times 10^{-4}$$

Considering the restraint exercised by concrete in cracked section on tension side, average strain

$$\epsilon_m = \epsilon_1 - \frac{b(h-x)(a-x)}{3E_s A_s (d.x)}$$

In this case

$$h = a = 600 \text{ mm}$$

$$x = 120.03 \text{ mm}$$

$$\begin{aligned}
 A_s &= 2513 \text{ mm}^2 \\
 E_s &= 2 \times 10^5 \text{ N/mm}^2 \\
 b &= b_w = 300 \text{ mm} \\
 d &= 550 \text{ mm}
 \end{aligned}$$

$$\begin{aligned}
 \therefore \epsilon_m &= 5.226 \times 10^{-4} - \frac{300(600 - 120.03)(600 - 120.03)}{3 \times 2 \times 10^5 \times 2513(550 - 120.03)} \\
 &= 4.16 \times 10^{-4}
 \end{aligned}$$

$$\begin{aligned}
 \text{At A, } c_{\min} &= 20 \text{ mm} \\
 a_{cr} &= 20 \text{ mm}
 \end{aligned}$$

$$\begin{aligned}
 \therefore W_{cr} &= \frac{3a_{cr} \epsilon_m}{1 + \frac{2(a_{cr} - c_{\min})}{(h - x)}} = \frac{3 \times 20 \times 4.16 \times 10^{-4}}{1 + 0} \\
 &= 0.025 \text{ mm}
 \end{aligned}$$

Ans.

QUESTIONS

1. Discuss in brief 'short term' and 'long term' deflections of R.C. beams.
2. List the factors influencing deflections of R.C. beams.
3. A rectangular simply supported beam of clear span 4.5 m is 300×500 mm in cross section. It is reinforced with 4 bars of 20mm diameter. M20 concrete and Fe 415 steel are used. The effective cover is 40 mm. Taking super imposed live load as 25 kN/m and dead load as 15 kN/m, calculate the short term and long term deflections of the beam.
4. A simply supported T-beam has the following data:
 - (i) Effective width of flange = 1500 mm
 - (ii) Thickness of flange = 130 mm
 - (iii) Width of rib = 250 mm
 - (iv) Effective depth = 500 mm
 - (v) Effective span = 6 m
 It is reinforced with 4 bars of 25 mm. The grade of concrete is M20 and the grade of steel is Fe 415.
 Determine the short term deflection due to a total service load of 30 kN/m. Use IS code specifications may be used for taking shrinkage strain and creep coefficients.
5. A beam of cross section 250×450 mm is reinforced with 4 bars of 20 mm with an effective cover of 50 mm. The effective span of the simply supported beam is 6 m. Using empirical formula check whether depth provided is satisfactory from the criteria of deflection control. Take grade of concrete as M20 and grade of steel as Fe 415. Assume that exactly required amount of steel is used.
6. Check the criteria of deflection control in case of the T-beam given in problem 4. Use empirical formula.
7. Calculate the maximum crack width under one of the bars in the beam given in question 5, when a bending moment of 70 kN-m acts.

Design of Beams

6.1 INTRODUCTION

Design of reinforced concrete beams involves sizing and finding required quantity of steel based on the consideration of strength and serviceability requirements. It also involves detailing. The major consideration in the design of beams is bending moment. Hence first, beams are designed for bending moment and then the design for shear is taken up. Checks are applied for deflection and crack width. If the requirement for any limit state fails redesign is to be made. The detailing of reinforcement is to be made with neat sketches/drawings taking into account bond, cracking and durability considerations. Some of these design considerations have been discussed in earlier chapters. In this chapter all design requirements are presented first and then various problems are solved to illustrate complete design procedure.

6.2 TYPES OF BEAMS

Designer has to decide whether the section of the beam is going to act as rectangular or L or as T-beam. A single span beam supported on masonry wall can be considered as simply supported beam (Fig. 6.1).

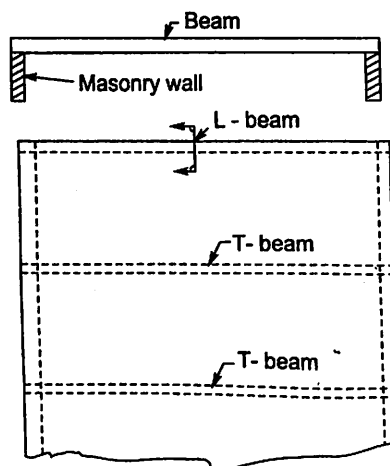

Fig. 6.1. Simply Supported Beam.

It has zero moments at ends and sagging (+ve) moment throughout. If slab is cast over it monolithically, the slab is on compression side. Hence when beam bends part of slab acts as flange of the beam in resisting bending moment. If the slab is on both sides, it becomes T-beam and if it is only on one side it is L-beam. This is illustrated in Fig. 6.1.

If the beam is part of a framed structure or is continuous over a number of supports, it will be having sagging (+ve) moment in mid span and hogging (-ve) moment near the supports. If as usual slab is on the top of the beam and is cast monolithically with beam, the mid span section of the beam becomes a flanged section. At interior supports, the flange is on tension side and hence will not assist in resisting moment. In such cases the beam is to be designed as a rectangular section for negative moment. This situation is shown in Fig. 6.2.

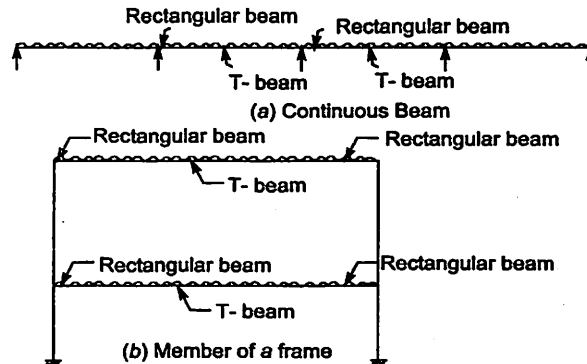

Fig. 6.2.

The designer has to decide whether the section is to be designed as singly reinforced or doubly reinforced. For this the depth of balanced section may be found. If this depth cannot be permitted from the consideration of head room requirement or from architectural consideration then the section is to be designed as doubly reinforced. Otherwise it may be designed as singly reinforced.

6.3 EFFECTIVE SPAN

For the calculation of bending moments and shear forces, effective span is to be considered. IS 456 clause No.22.2, specifies effective span, various cases as given below :

(i) **Simply supported beams or slabs**

$$\text{Effective span} = \text{clear span} + \text{effective depth}$$

Or

centre to centre distance between the supports,
whichever is less.

(ii) **Continuous beams or slabs (Fig. 6.3)**

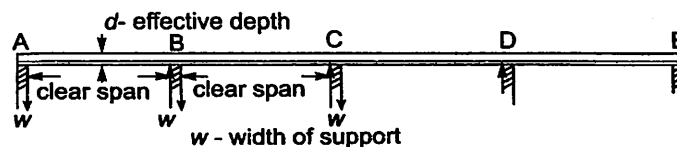

Fig. 6.3. Continuous Beam

- (a) If width of support, $w < \frac{1}{12}$ th of clear span, the effective span is same as for simply supported case.
 (b) For end span with one end simply supported and the other end continuous (span AB, DE in Fig. 6.3)

$$\text{Effective span} = \text{clear span} + \frac{1}{2}d$$

Or

clear span + $\frac{1}{2}$ the width of simple support
 whichever is less.

- (iii) **In case of roller supports (Fig. 6.4)**

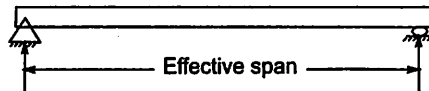

Fig. 6.4. Roller Supported Beam.

Effective span = distance between the supports.

- (iv) **Cantilevers (Fig. 6.5)**

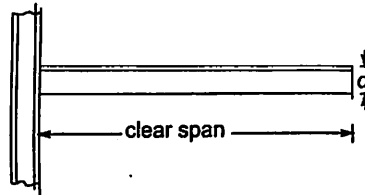

Fig. 6.5. Cantilever Beam.

$$\text{Effective span} = \text{clear span} + \frac{d}{2}$$

- (v) **Overhanging portion of continuous beams (Fig. 6.6)**

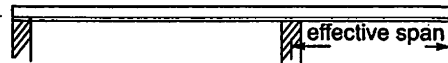

Fig. 6.6.

Effective span = Centre of support to free end.

- (vi) **Frames**

Effective span = centre to centre distance.

6.4 SIZE OF BEAM

- (i) **Depth of beam.** To get sufficient warning before the collapse of the beam under unexpected worst load case, it is desirable to keep the depth such that the percentage of steel required is around 75 per cent of that required for the balanced section. The another consideration in selecting the depth of the beam is to ensure that limit state of deflection

is not reached. If we select depth of beam as $\frac{1}{12}$ th to $\frac{1}{15}$ th of span, for simply supported beams and $\frac{1}{15}$ th to $\frac{1}{20}$ th of span for continuous beams, normally the above requirements are satisfied. Form the consideration of standardizing form works, overall depth is kept in multiples of 50 mm. Commonly used depths are 250 mm to 700 mm in multiples of 50 mm.

(ii) **Width of beam.** The width of beam should accommodate the required number of bars with sufficient spacing between them and ensuring minimum side cover requirement. However the bars may be accommodated in more than one layer also. The width is normally taken as 200 mm, 250 mm, 300 mm and 350 mm. Use of 230 mm is also common, since walls of width 230 mm (9" brick walls) are commonly constructed. The beam of width 230 mm will be flush with wall. The larger widths are preferred if the section is subjected to torsional moment. Clause 23.3 in IS 456 specifies the following slenderness ratio limits to ensure lateral stability:

- (a) A simply supported or continuous beam shall be so proportioned that the clear distance between the lateral restraints does not exceed $600b$ or $250 \frac{b^2}{d}$, whichever is less, where b is the width of beam and d is effective depth.
- (b) For a cantilever, the clear distance from the free end of the cantilever to the lateral restraint shall not exceed $25b$ or $100 \frac{b^2}{d}$, whichever is less.

From the above clauses, it may be observed that for about 12 m simply supported beams and 5m span cantilevers, beams can be 200 mm wide only. Since in practice minimum 200 mm width is used and simply supported beam of more than 12 m span and cantilevers of more than 5m are hardly built, the designer rarely face the problem of lateral stability of beams.

6.5 COVERS TO REINFORCEMENT

From the consideration of durability, minimum value of nominal cover to all normal weight aggregates is as shown in table 6.1 (Table 16 in IS 456):

Table 6.1 Nominal Cover to Meet Durability Requirements
(Clause 26.4.2, Table 16 in IS 456)

<i>Exposure Condition</i>	<i>Minimum Cover in mm</i>
Mild	20
Moderate	30
Sever	45
Very Sever	50
Extreme	75

Minimum nominal cover to meet specified fire resistance are also listed in IS-456 (table 16.1)

6.6 REQUIREMENT OF REINFORCEMENTS

(i) Main Reinforcement

The following guide lines are given for selecting main reinforcement:

- (a) Reinforcing steel of same type and grade shall be used as main reinforcement.
- (b) At least two bars should be used as tension steel and not more than six bars should be used in one layer in a beam.
- (c) The diameter of bars should not be less than 10mm. The usual diameter of bars chosen are 12, 16, 20, 22, 25 and 32 mm since they are easily available in the market. The bars of diameter 14, 18 and 28 mm may be obtained by placing special orders to steel mills. Due to delay in procuring them, the site engineers do not prefer to use them.
- (d) **Minimum Reinforcement** [Clause 26.5.1.a, IS 456] :
The minimum area of tension reinforcement shall be not less than that given by the following:

$$p_{t, \min} = \frac{A_{st}}{bd} = \frac{0.85}{f_y}$$

Thus for Fe 250, $p_{t, \min} = 0.34$

Fe 415, $p_{t, \min} = 0.205$

And for Fe 500, $p_{t, \min} = 0.17$

(e) Maximum Reinforcement:

The maximum area of tension reinforcement shall not exceed 0.04 bD [4 per cent of gross sectional area].

- (f) Bars may be arranged singly, or in pairs in contact or in groups. Bundled bars shall be enclosed within stirrups or ties. Bundled bars shall be tied together to ensure the bars remaining together. Bars larger than 32mm diameter shall not be bundled.

(ii) Shear Reinforcement:

- (a) This type of reinforcement shall be taken around the outermost tension and compression bars.
- (b) If no compression steel is used, two suspender bars of minimum 10 mm diameter should be used to support shear reinforcement.
- (c) The maximum spacing of shear reinforcement measured along the axis of the member shall not exceed $0.75d$ for vertical stirrups and d for inclined stirrups at 45° . In no case, the spacing shall exceed 300mm.
- (d) Minimum shear reinforcement in the form of stirrups shall be provided such that $\frac{A_{sv}}{b_{sv}} \geq \frac{0.4}{0.87f_y}$ with the notations as specified in Chapter III. The above provision need not be complied with, if maximum shear stress calculated is less than half the permissible value and in members of minor structural importance such as lintels.
- (e) When $\tau_c < \tau_v < \tau_{c, \max}$, shear strength of section may be enhanced by providing any of the following shear reinforcement:
 - Vertical stirrups
 - Bent up bars along with stirrups
 - Inclined stirrups
- (f) Shear reinforcement of diameter 6,8,10 or 12mm may be used. It may be of mild steel or Fe 415 grade steel.

(g) Two legged shear reinforcements are very commonly used. If spacing comes out too close, leading to problems in concreting, shear reinforcements of 4 legged or 6 legged also may be used.

(iii) Side Face Reinforcement.

Where the depth of a beam exceeds 750 mm, side face reinforcement shall be provided along the two faces. The total area of such reinforcement shall be not less than 0.1 per cent of the web area and shall be distributed equally on two faces at a spacing not exceeding 300mm or web thickness whichever is less.

6.7 GENERAL DESIGN PROCEDURE

In general, design procedure consists of the following steps:

- (i) Identify the critical sections to be designed.
- (ii) If slab is monolithically cast with beam (which is usual procedure of construction), carefully decide whether the section is to be designed as rectangular section or as flanged section.
- (iii) Fix up dimension of the beam using thumb rule guidance, which are based on controlling the deflections. If the same beam acts as rectangular section in some portion and as flanged beam in some other section, overall dimension is to be based on consideration of rectangular section and same is maintained throughout.
- (iv) Determine effective span.
- (v) Determine design moment and design shear.
- (vi) Design the section for flexure and determine longitudinal bars.
- (vii) Design the section for shear.
- (viii) Check for deflection.
- (ix) Sketch the details.

6.8 DESIGN OF SINGLY REINFORCED RECTANGULAR SECTIONS

- (i) Take the depth as $\frac{1}{12}$ th to $\frac{1}{15}$ th span (higher value for heavier loads). Round it off to nearest multiple of 50 mm.
- (ii) Take breadth as $\frac{1}{3}$ rd to $\frac{1}{2}$ the depth, minimum being 200 mm Round it off to multiple of 50mm. However 230 mm is also permitted.
- (iii) Determine $M_{u \text{ lim}}$.
- (iv) If $M_{u \text{ lim}} > M_u$, go to step (v); otherwise increase the depth.
- (v) Equating moment of resistance to bending moment, determine the area of steel required. For this,

$$C = T, \text{ gives}$$

$$0.36 f_{ck} b x_u = 0.87 f_y A_{st}$$

$$x_u = \frac{0.87 f_y A_{st}}{0.36 f_{ck} b}$$

or

$$\text{Moment of resistance} = \text{Design moment, gives}$$

$$T \times LA = M_u$$

$$0.87 f_y Ast (d - 0.42x_u) = M_u$$

$$\begin{aligned} \text{or } M_u &= 0.87 f_y Ast \left(d - \frac{0.42 \times 0.87 f_y Ast}{0.36 f_{ck} b} \right) \\ &= 0.87 f_y Ast d \left(1 - 1.05 \frac{Ast f_y}{bd f_{ck}} \right) \end{aligned}$$

$$\text{i.e. } M_u \approx 0.87 f_y Ast d \left(1 - \frac{Ast f_y}{bd f_{ck}} \right)$$

The above approximating relation is recommended by IS 456 (Annex G, IS 456)

The above quadratic equation in Ast is solved to get area of steel required. Then select suitable diameter and number of bars.

(vi) Design for shear consists of the following:

- Determine nominal shear $\tau_v = \frac{V_u}{bd}$.
- Find design shear strength of concrete τ_c using table no. 4.1 (table 19 in IS 456).
- If $\tau_v < \tau_c$ provide nominal shear reinforcement consisting of 2 legged 8mm (or 6mm) bars at not more than $0.75 d$ or 300mm whichever is less.
- If $\tau_c < \tau_v < \tau_{c \max}$, design shear reinforcement
- If $\tau_v > \tau_{c \max}$, revise the section.

Example 6.1. A rectangular beam is to be simply supported on supports of 230mm width. The clear span of the beam is 6m. The beam is to have width of 300mm. The characteristic super imposed load is 12 kN/m. Using M20 concrete and Fe 415 steel design the beam.

Solution.

Overall Dimension of the beam:

Width of beam = 300 mm, as specified in the problem.

$$\begin{aligned} \text{Depth of beam} &= \frac{1}{12} \text{ th to } \frac{1}{15} \text{ th span} \\ &= \frac{1}{12} \times 6000 \text{ to } \frac{1}{15} \times 6000 \\ &= 500 \text{ mm to } 400 \text{ mm} \end{aligned}$$

Let

$$d = 400 \text{ mm}$$

and

$$D = 450 \text{ mm}$$

Effective Span :

$$\text{Centre to centre of supports} = 6 + 0.23 = 6.23 \text{ m}$$

$$\text{Clear span} + d = 6 + 0.4 = 6.4 \text{ m}$$

$$\therefore \text{Effective span} = 6.23 \text{ m}$$

Design Moment (M_u) and Shear (V_u):

$$\text{Imposed load} = 12 \text{ kN/m}$$

$$\text{Self wt} = 0.3 \times 0.45 \times 1 \times 25 = 3.375 \text{ kN/m}$$

∴ Design load for strength consideration

$$\begin{aligned}w_u &= 1.5 \times 12 + 1.5 \times 3.375 \\ &= 23.06 \text{ kN/m}\end{aligned}$$

$$\therefore M_u = \frac{23.06 \times 6.23^2}{8} = 111.88 \text{ kNm}$$

Maximum shear occurs at support and is equal to half the total load.

$$\begin{aligned}V_u &= \frac{1}{2} w_u L = \frac{1}{2} \times 23.06 \times 6.23 \\ &= 71.83 \text{ kN}\end{aligned}$$

Check whether it can be singly reinforced section:

$$\begin{aligned}x_{u \text{ lim}} &= 0.48 d = 0.48 \times 400 = 192 \text{ mm.} \\ M_{u \text{ lim}} &= 0.36 f_{ck} b x_{u \text{ lim}} (d - 0.42 x_{u \text{ lim}}) \\ &= 0.36 \times 20 \times 300 \times 192 (400 - 0.42 \times 192) \\ &= 132.45 \times 10^6 \text{ N-mm} \\ &= 132.45 \text{ kN-m}\end{aligned}$$

$$(\text{or } M_{u \text{ lim}} = 0.138 f_{ck} b d^2)$$

Thus $M_{u \text{ lim}} > M_u$

Hence the section can be designed as singly reinforced section.

$$M_u = 0.87 f_y A_{st} d \left(1 - \frac{A_{st} f_y}{b d f_{ck}} \right)$$

$$111.88 \times 10^6 = 0.87 \times 415 \times A_{st} \times 400 \left(1 - \frac{A_{st}}{300 \times 400} \times \frac{415}{20} \right)$$

$$774.68 = A_{st} \left(1 - \frac{A_{st}}{5783.13} \right)$$

$$\text{or } A_{st}^2 - 5783.13 A_{st} + 774.68 \times 5783.13 = 0$$

$$\begin{aligned}A_{st} &= \frac{5783.13 - \sqrt{5783.13^2 - 4 \times 771.68 \times 5783.13}}{2} \\ &= 922 \text{ mm}^2.\end{aligned}$$

Provide 3 bars of 20mm diameter

$$A_{st \text{ provided}} = 3 \times \frac{\pi}{4} \times 20^2 = 942 \text{ mm}^2$$

Design of Shear Reinforcement :

$$\tau_v = \frac{V_u}{b d} = \frac{71.83 \times 1000}{300 \times 400} = 0.598 \text{ N/mm}^2$$

$$p_t = \frac{942}{300 \times 400} \times 100 = 0.785$$

From Table (19 in IS 456)

$$\tau_c = 0.57 \text{ N/mm}^2$$

$\tau_{c \text{ max}}$ (From table 20 in IS 456)

$$= 2.8 \text{ N/mm}^2$$

Thus,

$$\tau_c < \tau_v < \tau_{c \text{ max}}$$

\therefore Shear reinforcements are to be designed.

Total shear force $V_u = 71.832 \text{ kN} = 71832 \text{ N}$

Shear resisted by concrete $V_c = \tau_c \times bd$
 $= 0.57 \times 300 \times 400$

\therefore Shear to be resisted by reinforcements

$$\begin{aligned} V_{us} &= V_u - V_c \\ &= 71832 - 0.57 \times 300 \times 400 \\ &= 3432 \text{ N} \end{aligned}$$

Using 6mm, 2 legged Fe 250 steel as stirrups,

$$\begin{aligned} V_{us} &= \frac{0.87 f_y A_{sv} d}{S_v} \\ 3432 &= \frac{0.87 \times 250 \times 2 \times \frac{\pi}{4} \times 6^2 \times 400}{S_v} \end{aligned}$$

$$\therefore S_v = 1433 \text{ mm}$$

But maximum spacing permitted is

(a) $0.75 d = 0.75 \times 400 = 300 \text{ mm}$

(b) 300 mm

Hence provide 2 legged 6mm stirrups at 300 mm c.c throughout

Check for Deflection :

Since it is simply supported beam,

basic $\frac{L}{d} = 20$

Modification Factor for Tensile Steel (F_1):

$$p_t = 0.785$$

$$\therefore f_s = 0.58 \times f_y \times \frac{\text{Area of Ast required}}{\text{Ast Provided}}$$

$$= 0.58 \times 415 \times \frac{942}{922}$$

$$= 246 \text{ N/mm}^2$$

\therefore From Fig 4, in IS 456

$$F_1 = 1.1$$

No. compressive steel, $F_2 = 1$

Not flanged section, $\therefore F_3 = 1$

\therefore Maximum permitted $\frac{L}{d}$ ratio = $F_1 F_2 F_3 \times 20$

$$= 1.1 \times 1 \times 1 \times 20 = 22$$

$$\frac{L}{d} \text{ provided} = \frac{6230}{400} = 15.575$$

Thus, $\frac{L}{d} \text{ provided} < \text{Max } \frac{L}{d} \text{ permitted}$.

Hence deflection control is satisfactory. Crack width control is taken care by satisfying detailing requirements.

Details are shown in Fig. 6.7

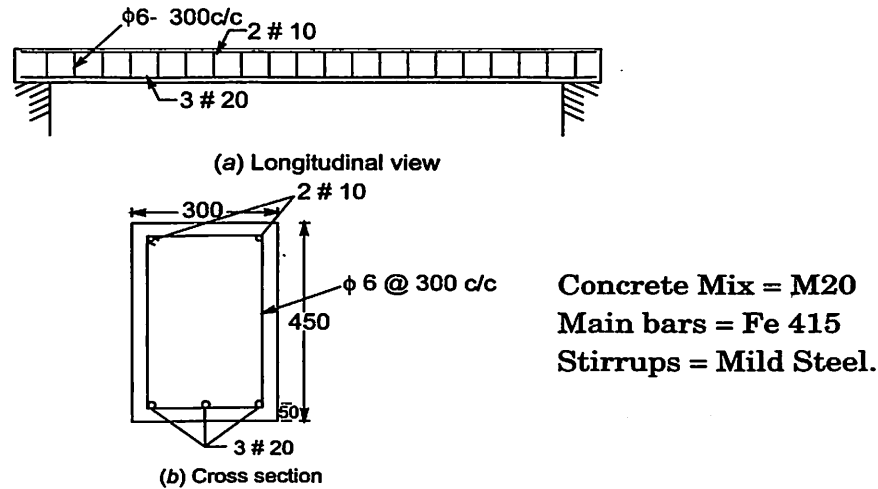

Fig. 6.7 Details of Reinforcements.

6.9 DESIGN OF DOUBLY REINFORCED RECTANGULAR SECTIONS

In case of doubly reinforced section design, the depth of beam is known from other considerations. The width can be selected suitably. For the section selected

(i) Find $M_{u \text{ lim}}$ using the formula

$$\begin{aligned} M_{u \text{ lim}} &= 0.36 fck b x_{u \text{ lim}} (d - 0.42 x_{u \text{ lim}}) \\ &= 0.36 fck x_{u \text{ lim}} (d - 0.42 x_{u \text{ lim}}) \\ &= 0.36 fck \frac{x_{u \text{ lim}}}{d} \left(1 - 0.42 \frac{x_{u \text{ lim}}}{d} \right) bd^2 \\ &= 0.148 fck bd^2 \text{ for Fe 250} \\ &= 0.138 fck bd^2 \text{ for Fe 415} \\ &= 0.133 fck bd^2 \text{ for Fe 500} \end{aligned}$$

(ii) When $M_u > M_{u \text{ lim}}$, doubly reinforced section is to be designed. In the design depth of neutral axis $x = x_{u \text{ lim}}$

(iii) Find Ast_1 required to resist $M_{u \text{ lim}}$, as singly reinforced section. For this horizontal force equilibrium gives

$$C = T$$

$$0.36 f_{ck} b x_{u \text{ lim}} = 0.87 f_y Ast_1.$$

(iv) Now find $M_{u2} = M_u - M_{u \text{ lim}}$

The moment M_{u2} is the moment of resistance to be provided by compressive steel and additional tensile steel Ast_2 .

$$\therefore M_{u2} = 0.87 f_y Ast_2 (d - d')$$

where d' is the cover to compression steel. The above expression gives additional tensile steel Ast_2 . Hence total tensile steel required is given by

$$Ast = Ast_1 + Ast_2$$

(v) From strain diagram (which is linear), we get

$$\epsilon_{sc} = 0.0035 \frac{x_{u \text{ lim}} - d'}{x_{u \text{ lim}}}$$

where ϵ_{sc} is the strain in compression steel. Then find the corresponding stress f_{sc} . For this use stress strain diagram for steel (Fig. 23 in IS 456) or table A in SP-16. Pick up the value

corresponding to the curve $\frac{f_y}{1.15}$.

Find area of compression steel, A_{sc} required from the relation

$$f_{sc} A_{sc} = 0.87 f_y Ast_2$$

Then select tensile and compression bars.

(vi) Design procedure for shear reinforcement is same as used in singly reinforced sections.

Example 6.2. Design a rectangular beam of section 230 mm × 600 mm of effective span 6 m. Effective cover for reinforcement should be kept as 50 mm. Imposed load on the beam is 40 kN/m. Use M20 concrete and Fe 415 steel.

Solution.

Given :

$$b = 230 \text{ mm}$$

$$d = 500 \text{ mm}$$

$$f_{ck} = 20 \text{ N/mm}^2$$

$$D = 600 \text{ mm}$$

$$d' = 50 \text{ mm}$$

$$f_y = 415 \text{ N/mm}^2$$

Self weight

$$= 0.230 \times 0.600 \times 1 \times 25 = 3.45 \text{ kN/m}$$

Imposed load

$$= 40 \text{ kN/m}$$

∴ Total load

$$= 40 + 3.45 = 43.45 \text{ kN/m}$$

∴ Factored load

$$w_u = 1.5 \times 43.45 \text{ kN/m}$$

Effective span

$$= 6 \text{ m}$$

∴ Design (Factored) moment

$$\begin{aligned} M_u &= w_u \frac{\ell^2}{8} = 1.5 \times 43.45 \times \frac{6^2}{8} \\ &= 293.29 \text{ kN-m} \end{aligned}$$

Design shear

$$\begin{aligned} &= \frac{1}{2} w_u \ell = \frac{1}{2} \times 1.5 \times 43.45 \times 6 \\ &= 195.525 \text{ kN} \end{aligned}$$

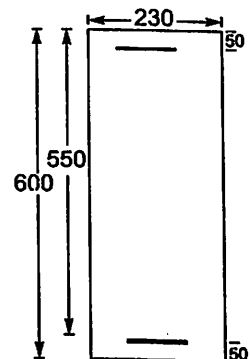

Fig 6.8

Limiting Moment:

$$x_{u \text{ lim}} = 0.48 d = 0.48 \times 550 = 246 \text{ mm}$$

$$\begin{aligned} M_{u \text{ lim}} &= 0.36 f_{ck} b x_{u \text{ lim}} (d - 0.42 \times x_{u \text{ lim}}) \\ &= 191.976 \times 10^6 \text{ N-mm} \\ &= 191.976 \text{ kN-m} \end{aligned}$$

Thus

$$M_u > M_{u \text{ lim}}$$

To find Ast_1 to resist $M_{u \text{ lim}}$:

$$C = T \text{ gives}$$

$$0.36 \times f_{ck} b x_{u \text{ lim}} = 0.87 f_y Ast_1$$

$$0.36 \times 20 \times 230 \times 264 = 0.87 \times 415 Ast_1$$

$$\therefore Ast_1 = 1210.9 \text{ mm}^2$$

To find Ast_2

$$\begin{aligned} \epsilon_{sc} &= 0.0035 \left(\frac{x_{u \text{ lim}} - d'}{x_{u \text{ lim}}} \right) \\ &= 0.035 \times \frac{264 - 50}{264} \\ &= 2.837 \times 10^{-3} \end{aligned}$$

From stress strain curve for Fe 415, corresponding $\frac{f_y}{1.15}$,

$$f_{sc} = 352 \text{ N/mm}^2$$

Equating horizontal compressive force to, horizontal tensile force corresponding to Ast_2 , we get,

$$f_{sc} A_{sc} = 0.87 f_y Ast_2$$

$$352 A_{sc} = 0.87 \times 415 \times 561.2$$

$$\therefore A_{sc} = 575.6 \text{ mm}^2$$

Reinforcements:

Provide 6 bars of 20mm in tension zone (Ast provided = 1885 mm²) and 2 bars of 20mm diameter (A_{sc} provided = 628 mm²) in compression zone.

Design for Shear:

$$V_u = 195.525 \text{ kN} = 195525 \text{ N}$$

$$\tau_v = \frac{V_u}{bd} = \frac{195525}{230 \times 550} = 1.546 \text{ N/mm}^2$$

$$p_t = \frac{Ast}{bd} \times 100 = \frac{1885 \times 100}{230 \times 550} = 1.49$$

From table 19 in IS 456,

$$\tau_c = 0.718 \text{ N/mm}^2$$

From table 20, in IS 456

$$\tau_{c \text{ max}} = 2.8 \text{ N/mm}^2$$

Thus,

$$\tau_c < \tau_v < \tau_{c \max}$$

∴ Shear reinforcement is to be designed.

Shear to be taken by steel reinforcement,

$$\begin{aligned} V_{us} &= V_u - \tau_c bd \\ &= 195525 - 0.718 \times 230 \times 550 \\ &= 104698 \text{ N} \end{aligned}$$

Using 2 legged, 8mm vertical stirrups, spacing S_v , may be found from the relation,

$$\begin{aligned} V_{us} &= \frac{0.87 f_y A_{sv} d}{S_v} \\ 104698 &= \frac{0.87 \times 415 \times \left(2 \times \frac{\pi}{4} \times 8^2\right) \times 550}{S_v} \end{aligned}$$

$$\therefore S_v = 190.67 \text{ mm}$$

Maximum spacing permitted = $0.75 d = 0.75 \times 550 = 412.5 \text{ mm}$ or 300 whichever is less.

Hence $S_v = 190 \text{ mm}$ is sufficient.

Provide spacing of 190mm near the support and gradually increase it to 300mm towards the centre of the span.

Check for Deflection: Since it is simply supported beam

$$\text{Basic } \frac{L}{d} = 20$$

$$p_t = 1.49$$

$$f_s = 0.58 f_y \frac{A_{st \text{ required}}}{A_{st \text{ provided}}}$$

$$= 0.58 \times 415 \times \frac{1772.1}{1885} = 226 \text{ N/mm}^2$$

∴ From Fig. 4 in IS 456, modification factor for providing tensile steel,

$$F_1 = 0.98$$

$$p_c = \frac{A_{sc}}{bd} \times 100 = \frac{628}{230 \times 550} \times 100 = 0.496$$

∴ From Fig. 5 in IS 456, modification factor for providing steel

$$F_2 = 1.15$$

Since this is not flanged section

$$F_3 = 1.0$$

∴ Maximum $\frac{L}{d}$ permitted

$$= F_1 F_2 F_3 \text{ basic } \frac{L}{d}$$

$$= 0.98 \times 1.15 \times 1 \times 20 = 22.54$$

$$\frac{L}{d} \text{ provided} = \frac{6000}{550} = 10.91 < 22.54$$

Hence deflection control is satisfactory

Detailing

Since it is not possible to accommodate 6 bars in a row within 230 mm width so as to get minimum side covers and minimum spacing between the bars, reinforcement is provided in two rows as shown in Fig. 6.9

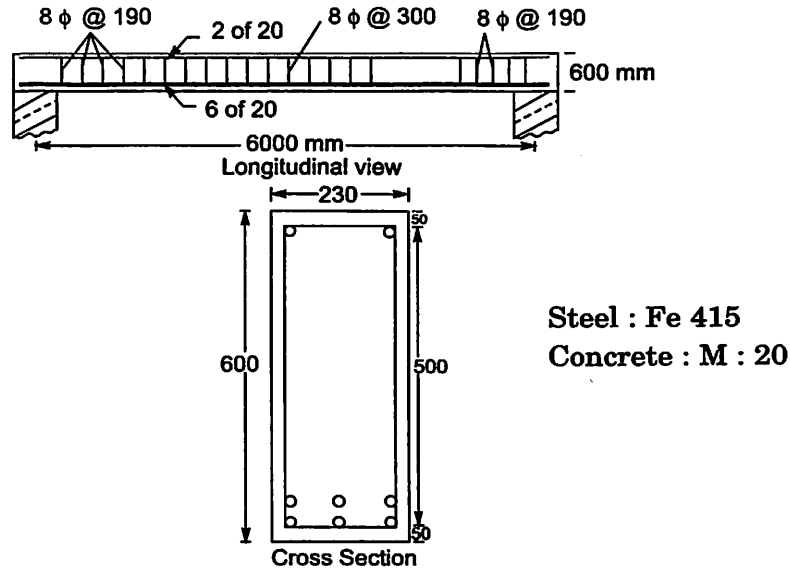

Fig. 6.9.

6.10 DESIGN OF FLANGED BEAMS

The following steps are involved in the design:

- (i) Fix up the overall dimensions as usual.
- (ii) To the given super imposed load add the self weight of rib, which is equal to

$$= \frac{b_w}{1000} \times \frac{(D - D_f)}{1000} \times 1 \times 25 \text{ kN, if } b_w, D \text{ and } D_f \text{ are in mm units.}$$

- (iii) Find design moment M_u and design shear V_u .
- (iv) Calculate effective width of flange.
- (v) In the design for longitudinal reinforcement many cases arise.
 - (a) Assuming uniform compression in the flange and neglecting contribution of rib in resisting moment. Calculate $M_{u \text{ lim}}$. Then

$$M_{u \text{ lim}} = 0.446 f_{ck} b_f D_f (d - 0.5 D_f)$$

If $M_u > M_{u \text{ lim}}$, doubly reinforced section is to be designed.

- (b) If $M_u < M_{u \text{ lim}}$, determine moment of resistance of flange M'_u , assuming $x_u = D_f$.

$$M'_u = 0.36 f_{ck} b_f D_f (d - 0.42 D_f)$$

If $M_u < M'_u$, the neutral axis $x_u < D_f$. Hence, compression area is rectangle of size $b_f x_u$. Find A_{st} from the relation,

$$M_u = 0.87 f_y A_{st} d \left[1 - \frac{A_{st} f_y}{bd f_{ck}} \right]$$

(c) If $M_u > M'_u$ but less than $M_{u\text{lim}}$, determine M''_u , the moment of resistance of the beam when $\frac{3}{7}x_u = D_f$ i.e., $x_u = \frac{7}{3}D_f$

$$M''_u = 0.36 f_{ck} b_w x_u (d - 0.42x_u) + 0.446 f_{ck} (b_f - b_w) D_f (d - 0.5D_f)$$

If $M_u < M''_u$, it is a case of non-uniform stress in flange. In such case x_u is to be found by trial and error method.

- Assume x_u
- M_u , cal = $0.36 f_{ck} b_w x_u (d - 0.42x_u) + 0.446 f_{ck} (b_f - b_w) y_f (d - 0.5y_f)$
- Compare it with M_u

When calculated M_u is close to actual M_u , assumed x_u is correct. Then equating tensile force to compressive force, A_{st} can be found

$$0.87 f_y A_{st} = 0.36 f_{ck} b_w x_u + 0.446 f_{ck} (b_f - b_w) y_f$$

(d) If

$$M_u < M_{u\text{lim}} \\ > M'_u$$

and $> M''_u$, then it is case of uniform compression in flange. Then find exact x_u using the expression,

$$M_u = 0.36 f_{ck} b x_u (d - 0.42x_u) + 0.446 f_{ck} (b_f - b_w) D_f (d - 0.5D_f)$$

Equating tensile force to compressive force, we get,

$$0.87 f_y A_{st} = 0.36 f_{ck} b_w x_u + 0.446 f_{ck} (b_f - b_w) D_f$$

A_{st} required can be found and required bars selected.

(vi) Shear reinforcement is designed taking it as a rectangular section of size $b_w \times d$. The design procedure is illustrated with the problems below:

Example 6.3 A T-Beam slab floor has 125mm thick slab forming part of T-beams which are of 8m clear span. The end bearing are 450mm thick. Spacing of T-beams is 3.5m. The live load on the floor is 3 kN/m². Design one of the intermediate beams. Use M20 concrete and Fe 415 steel.

Solution.

$$\begin{array}{ll} D_f = 125 \text{ mm} & \text{Spacing} = 3.5 \text{ m} \\ LL = 3 \text{ kN/m}^2 & f_{ck} = 20 \text{ N/mm}^2 \\ f_y = 415 \text{ N/mm}^2 & \text{Clear span} = 8 \text{ m} \end{array}$$

End bearing width = 450 mm

Dimensions of Beam:

$$\begin{aligned} \text{Depth} &= \frac{1}{12} \text{ th to } \frac{1}{15} \text{ th span} \\ &= \frac{1}{12} \times 8000 \text{ to } \frac{1}{15} \times 8000 \end{aligned}$$

$$= 667 \text{ mm to } 533.3 \text{ mm}$$

Let $d = 600 \text{ mm}$
and $D = 650 \text{ mm}$

$$b_w = \frac{1}{2} \text{ to } \frac{1}{3} d$$

Let $b = 250 \text{ mm}$

Effective Span:

$$\text{Clear Span} + d = 8 + 0.6 = 8.6 \text{ m}$$

$$\text{c/c of bearings} = 8 + 0.45 = 8.45 \text{ m}$$

$$\therefore \text{Effective span} = 8.45 \text{ m}$$

Flange Width:

$$(a) b_f = \frac{l_0}{6} + b_w + 6D_f$$

Since it is simply supported, $l_0 = L = 8.45 \text{ m} = 8450 \text{ mm}$

$$b_f = \frac{8450}{6} + 250 + 6 \times 125 = 2408 \text{ mm}$$

$$(b) b_f = 0.5 (L_1 + L_2) + b_w \text{ i.e c/c of adjacent slabs}$$

$$= 3.5 \text{ m} = 3500 \text{ mm}$$

$$\therefore b_f = 2408 \text{ mm}$$

The cross section of the beam to be designed is as shown in Fig. 6.10

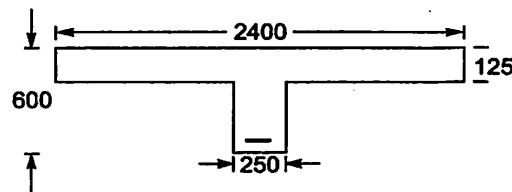

Fig. 6.10.

Design Moment (M_u) and shear force (V_u):

Load per meter run of beam is calculated as shown below:

Load from slab

$$\text{Self weight of slab} = 0.125 \times 1 \times 1 \times 25 = 3.125 \text{ kN/m}^2$$

$$\text{Weight of floor finish} = 0.6 \text{ kN/m}^2 \text{ (assumed)}$$

$$\text{Live load} = 3 \text{ kN/m}^2$$

$$\text{Total } 6.725 \text{ kN/m}^2$$

Since beam is taking case of 3.5 m width of slab.

$$\text{Load on beam from slab} = 6.725 \times 1 \times 3.5 = 23.577 \text{ kN/m}$$

Self weight of rib :

$$\text{Width of rib} = 250 \text{ mm} = 0.25 \text{ m}$$

$$\text{Depth of rib} = 650 - 125 = 525 \text{ mm} = 0.525 \text{ m}$$

$$\therefore \text{Self weight of rib} = 0.25 \times 0.525 \times 1 \times 25 = 3.28 \text{ kN/m}$$

$$\text{Weight of plaster to rib} = 0.5 \text{ kN/m (assumed)}$$

$$\therefore \text{Total load on beam} = 23.577 + 3.28 + 0.5 \\ = 27.3 \text{ kN/m}$$

$$\text{Factored load } w_u = 1.5 \times 27.3 = 40.95 \text{ kN/m}$$

$$\therefore M_u = \frac{w_u \ell^2}{8} = 40.95 \times \frac{8.45^2}{8} = 365.5 \text{ kN-m}$$

$$V_u = \frac{1}{2} \times w_u \ell = \frac{1}{2} \times 40.95 \times 8.45 = 173 \text{ kN}$$

Design of Longitudinal Bars:

$$x_{u \text{ lim}} = 0.48 d = 0.48 \times 600 = 288 \text{ mm}$$

Neglecting contribution of rib and assuming uniform compression in flange,

$$M_{u \text{ lim}} = 0.446 f_{ck} b_f D_f (d - 0.5 D_f) \\ = 0.446 \times 20 \times 2408 \times 125 (600 - 0.5 \times 125) \\ = 1443.145 \times 10^6 \text{ N-mm}$$

$\therefore M_u < M_{u \text{ lim}}$. It can be designed as singly reinforced section.

Assuming neutral axis coincides with flange

$$x_u = D_f = 125 \text{ mm}$$

$$M'_u = 0.36 f_{ck} b_f D_f (d - 0.42 D_f) \\ = 0.36 \times 20 \times 2408 \times 125 (600 - 0.42 \times 125) \\ = 1186.542 \times 10^6 \text{ N-mm}$$

Thus $M_u < M'_u$ i.e. N-A is within the flange. Let depth of N-A from extreme compression flange be x_u . Then equating moment to moment of resistance, we get,

$$365.5 \times 10^6 = 0.87 \times 415 \times A_{st} \times 600 \left[1 - \frac{A_{st}}{2408 \times 600} \times \frac{415}{20} \right]$$

$$1687.21 = A_{st} \left[1 - \frac{A_{st}}{69628.9} \right]$$

$$A_{st}^2 - 69628.9 A_{st} + 1687.21 \times 69628.9 = 0$$

$$A_{st} = \frac{69628.9 - \sqrt{69628.9^2 - 4 \times 1687.21 \times 69628.9}}{2}$$

$$= 1730 \text{ mm}^2$$

Provide 6 bars of 20mm diameter

$$A_{st \text{ provided}} = 6 \times \frac{\pi}{4} \times 20^2 = 1885 \text{ mm}^2$$

Design of Shear Reinforcement

$$p_t = \frac{1885}{250 \times 600} \times 100 = 1.257$$

From table 19 in IS 456,

$$\tau_c = 0.67 \text{ N/mm}^2$$

$$\tau_v = \frac{V_u}{bd} = \frac{173 \times 1000}{250 \times 600} = 1.153 \text{ N/mm}^2$$

From table 20 in IS 456

$$\tau_{c\max} = 2.8 \text{ N/mm}^2$$

$$\therefore \tau_c < \tau_v < \tau_{c\max}$$

Shear reinforcement is to be designed.

$$\begin{aligned} V_{us} &= V_u - \tau_c bd \\ &= 173000 - 0.67 \times 250 \times 600 \\ &= 72500 \text{ N} \end{aligned}$$

Using 2 legged 8mm diameter Fe 415 steel as vertical stirrups, spacing S_v can be found from the relations,

$$\begin{aligned} V_{us} &= \frac{0.87 f_y A_{sv} d}{S_v} \\ 72500 &= \frac{0.87 \times 415 \times 2 \times \frac{\pi}{4} \times 8^2 \times 600}{S_v} \end{aligned}$$

$$\therefore S_v = 300.39 \text{ mm}$$

Maximum spacing allowed is $0.75 \times 600 = 450\text{mm}$ or 300mm , whichever is less. Hence provide 2 legged 8mm dia Fe 415 stirrups throughout at 300mm c/c .

Check for Deflection Control:

As it is simply supported beam,

$$\text{basic } \frac{L}{d} = 20$$

$$p_t = 1.257$$

$$A_{st} \text{ required} = 1730 \text{ mm}^2$$

$$A_{st} \text{ provided} = 1885 \text{ mm}^2$$

$$\therefore f_s = 0.58 \times \frac{1730}{1885} \times 415 = 220.9 \text{ N/mm}^2$$

\therefore From Fig.4 in IS 456, modification factor

$$F_1 = 1.0$$

No compression steel. Hence from Fig.5 in IS 456, $F_2 = 1.0$

$$\frac{b_w}{b_f} = \frac{250}{2408} = 0.104$$

\therefore From Fig.6 in IS 456,

$$F_3 = 0.8$$

$$\frac{L}{d} \text{ max} = F_1 F_2 F_3 \text{ basic value}$$

$$= 1 \times 1 \times 0.8 \times 20 = 16$$

$$\frac{L}{d} \text{ provided} = \frac{8450}{600} = 14 < \frac{L}{d} \text{ max}$$

Hence deflection control is satisfactory.

As 6 bars of 20 mm diameter cannot be accommodated in 250 mm width with sufficient side cover and gap between the bars, provide bars in two rows as shown in Fig. 6.11

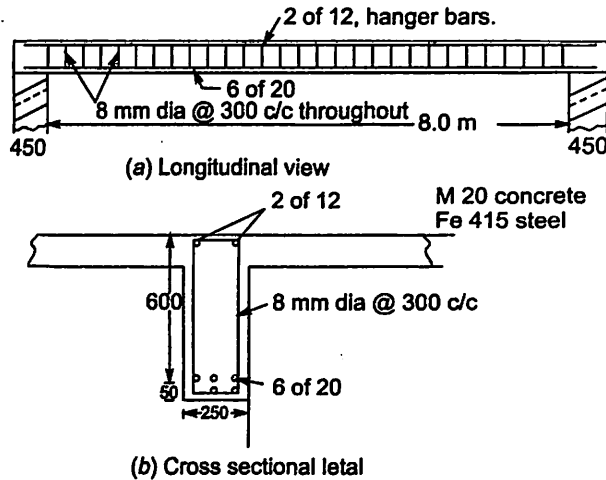

Fig. 6.11.

Example 6.4. Calculate the area of longitudinal reinforcement required for a L-beam for an ultimate bending moment of (a) 340 kN-m (b) 430 kN-m and (c) 520 kN-m

Given :

L-beam flange width = 1100 mm

Flange thickness = 120 mm

Width of web = 300 mm

Overall depth = 500 mm

Effective cover = 60 mm

Concrete = M20

Steel = Fe 415

Solution.

The section is shown in Fig 6.12

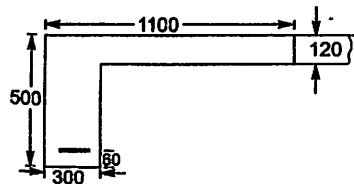

Fig. 6.12.

$$\text{Effective depth } d = 500 - 60 = 440 \text{ mm}$$

$$x_{u \text{ lim}} = 0.48 \times 440 = 211.2 \text{ mm}$$

Neglecting contribution of rib in resisting moment and assuming uniform compression in flange,

$$\begin{aligned} M_{u \text{ lim}} &= 0.446 f_{ck} b_f D_f (d - 0.5 D_f) \\ &= 0.446 \times 20 \times 1100 \times 120 (440 - 0.5 \times 120) \\ &= 461.47 \times 10^6 \text{ N-mm} \\ &= 461.47 \text{ kN-m} \end{aligned}$$

(a) $M_u = 340 \text{ kN-m}$

$$M_u < M_{u \text{ lim}}$$

\therefore Singly reinforced section can be designed.

Assuming N-A is exactly at $x_u = D_f$

$$\begin{aligned} M'_u &= 0.446 f_{ck} b_f D_f (d - 0.5 D_f) \\ &= 0.36 \times 20 \times 1100 \times 120 (440 - 0.5 \times 120) \\ &= 360.115 \times 10^6 \text{ N-mm} \end{aligned}$$

In this case $M_u < M'_u$ i.e. neutral axis is within the flange i.e. $x_u < D_f$. Hence compression area is a rectangle of size $b_f \times x_u$. From the relation,

$$M_u = 0.87 f_y A_{st} d \left[1 - \frac{A_{st} f_y}{b d f_{ck}} \right], \text{ we have}$$

$$340 \times 10^6 = 0.87 \times 415 \times A_{st} \times 440 \left[1 - \frac{A_{st}}{1100 \times 440} \times \frac{415}{20} \right]$$

$$2140.2 = A_{st} \left[1 - \frac{A_{st}}{23325.3} \right]$$

$$\text{i.e., } A_{st}^2 - 23325.3 A_{st} + 2140.2 \times 23325.3 = 0$$

$$\begin{aligned} A_{st} &= \frac{23325.3 - \sqrt{23325.3^2 - 4 \times 2140.0 \times 23325.3}}{2} \\ &= 2384 \text{ mm}^2 \text{ Ans.} \end{aligned}$$

(b) $M_u = 430 \text{ kN-m}$

In this case $M_u > M'_u$ and it is less than $M_{u \text{ lim}}$. To check whether it is a case of uniform stress in flange $\left(\frac{3}{7} x_u \geq D_f \right)$ or non-uniform stress $\left(\frac{3}{7} x_u < D_f \right)$ M''_u is to be found which is the moment when $\frac{3}{7} x_u = D_f$.

$$\text{i.e. } x_u = \frac{7}{3} D_f = \frac{7}{3} \times 120 = 280 \text{ mm}$$

But this value is more than $x_{u \text{ lim}}$. This situation is not permitted.

Hence $\left(\frac{3}{7} x_u < D_f \right)$ i.e. it is a case of non uniform stress in flange. In such case x_u is to be found by trial and error method. Since $x_u > D_f$ but $< x_{u \text{ lim}}$, let us try

$$x_u = 180 \text{ mm}$$

$$y_f = 0.15 x_u + 0.65 D_f = 0.15 \times 180 + 0.65 \times 120 = 105 \text{ mm}$$

∴ Trial 1, moment of resistance

$$\begin{aligned} M_{u1} &= 0.36 f_{ck} b_w x_u (d - 0.42 x_u) + 0.446 f_{ck} (b_f - b_w) y_f (d - 0.5 y_f) \\ &= 0.36 \times 20 \times 300 \times 180 (400 - 0.42 \times 180) + 0.446 \times 20 \\ &\quad (1100 - 300) \times 105 (440 - 0.5 \times 105) \\ &= 432.025 \times 10^6 \text{ N-mm} \end{aligned}$$

Thus $M_u < M_{u1}$

i.e. actual x_u is slightly less than assumed x_u .

Trial 2 : Let

$x_u = 175$ mm. Then

$$y_f = 0.15 \times 175 + 0.65 \times 120 = 104.25 \text{ mm}$$

$$\begin{aligned} M_{u2} &= 0.36 \times 20 \times 300 \times 175 (440 - 0.42 \times 175) + 0.446 \times 20 \\ &\quad (1100 - 300) \times 104.25 (440 - 0.5 \times 104.25) \\ &= 427.088 \times 10^6 \text{ N-mm} \end{aligned}$$

M_u is slightly less than M_{u2}

x_u should be within 180mm and 175 mm

Let us assume

$M_u = M_{\text{trial}}$ when $x_u = 178$ mm

Then equating compression force to tensile force we get,

$$0.87 f_y A_{st} = 0.36 f_{ck} b_w x_u + 0.446 f_{ck} (b_f - b_w) y_f$$

In this case

$$y_f = 0.15 \times 178 + 0.65 \times 120 = 104.7 \text{ mm}$$

$$\therefore 0.87 \times 415 A_{st} = 0.36 \times 20 \times 300 \times 178 + 0.446 \times 20 (1100 - 300) \times 104.7$$

$$\therefore A_{st} = 3134 \text{ mm}^2.$$

Ans.

(c) $M_u = 520$ kN-m

In this case $M_u > M_{u \text{ lim}}$. Hence doubly reinforced section is to be designed.

$$M_{u \text{ lim}} = 461.47 \text{ kN-m}$$

$$0.87 f_y A_{st1} (d - 0.42 x_{\text{lim}}) = M_{u \text{ lim}}$$

$$0.87 \times 415 A_{st1} (440 - 0.42 \times 211.2) = 461.47 \times 10^6$$

$$\therefore A_{st1} = 3638 \text{ mm}^2.$$

Considering moment of resistance offered by compressive force in steel and tensile force in additional tensile steel, we get,

$$0.87 f_y A_{st2} (d - d') = M_u - M_{u \text{ lim}}$$

$$0.87 \times 415 A_{st2} (440 - 60) = 520 \times 10^6 - 461.47 \times 10^6$$

$$\therefore A_{st2} = 427 \text{ mm}^2.$$

$$\therefore A_{st} = A_{st1} + A_{st2} = 3638 + 427 = 4065 \text{ mm}^2.$$

As strain varies linearly from zero at neutral axis to 0.0035 at extreme compression fibre, strain in compression steel is given by

$$\begin{aligned} \epsilon_{sc} &= 0.0035 \left(\frac{x_{u \text{ lim}} - d}{x_{u \text{ lim}}} \right) = 0.0035 \frac{211.2 - 50}{211.2} \\ &= 2.675 \times 10^{-3} \end{aligned}$$

From stress strain curve design stress in compression steel

$$f_{sc} = 0.83 f_y = 0.83 \times 415 = 344.45 \text{ N/mm}^2$$

Equating compressive force in steel to tensile force in additional steel, we get,

$$f_{sc} A_{sc} = 0.87 f_y A_{st2}$$

$$344.45 \times A_{sc} = 0.87 \times 427 \times 415$$

$$\therefore A_{sc} = 448 \text{ mm}^2$$

Thus $A_{st} = 4065 \text{ mm}^2$

and $A_{sc} = 448 \text{ mm}^2$. **Ans.**

Thus $A_{st} = 4065 \text{ mm}^2$ and $A_{sc} = 448 \text{ mm}^2$ **Ans.**

6.11 DESIGN OF CANTILEVER BEAMS

Design procedure for such beams do not differ from the design of simply supported beams. However the designer has to carefully remember the following points:

- (i) Maximum value of $\frac{L}{d}$ permitted is 7 i.e. select trial section depth around $\frac{1}{7}$ th span.
- (ii) Expression for moment and shear forces are different. For example, in case of *udl* over entire span

$$M_u = w_u \frac{\ell^2}{2} \quad \text{and} \quad V_u = w_u \ell$$

- (iii) For the usual downward loading, tension is at top. Hence reinforcement is to be given at the top.
- (iv) Anchorage length should be provided near fixed end of cantilever beyond the support so that steel develops design stress of $0.87f_y$ at the support.

The procedure is illustrated with the example below:

Example 6.5. *The portico of a guest house building consists of cantilever beams of effective span 3m, spaced at 2.5m centre to centre. The beams support 120mm thick slab. Live load on slab is 1.5 kN/m². Using concrete mix of M20 and steel Fe 415, design an intermediate beam, if slab is flush with*

- (a) top of beams
- (b) bottom of beams

Solution.

$$\begin{aligned} \text{Effective span} &= 3 \text{ m} \\ \text{Spacing of beams} &= 2.5 \text{ m} & D_f &= 120 \text{ mm}^2 \\ f_{ck} &= 20 \text{ N/mm}^2 & \text{and} & f_y &= 415 \text{ N/mm}^2 \end{aligned}$$

Cross Sectional Dimensions

$$\text{Depth of section} = \frac{1}{7} \text{ th span} = \frac{1}{7} \times 3000 = 428 \text{ mm}$$

$$\text{Let us select} \quad d = 450 \text{ mm} \quad \text{and} \quad D = 500 \text{ mm}$$

$$b = \frac{1}{3} \text{ to } \frac{1}{2} \text{ depth}$$

$$\text{Let us select} \quad b = 250 \text{ mm}$$

Design Moment M_u and shear force V_u

Dead Load of slab	$= 0.120 \times 1 \times 2.5 \times 25$	$= 7.5 \text{ kN/m}$
L.L. from slab	$= 1.5 \times 2.5$	$= 3.75 \text{ kN/m}$
Wt. of rib	$= 0.25 (0.500 - 0.120) \times 25$	$= 2.375 \text{ kN/m}$
		<u>Total = 13.625 kN/m</u>

Say with finishing load $w = 14 \text{ kN/m}$

$$\therefore w_u = 1.5 \times 14 = 21 \text{ kN/m}$$

$$M_u = w_u \frac{\ell^2}{2} = 21 \times \frac{3^2}{2} = 94.5 \text{ kN-m}$$

$$V_u = w_u \ell = 21 \times 3 = 63 \text{ kN}$$

(i) If slab is flush with the top of beams

In cantilevers tension is on the top. Hence slab will not assist in resisting moment. Therefore beam is to be designed as a cantilever of rectangular section

$$x_{u \text{ lim}} = 0.48 d = 0.48 \times 450 = 216 \text{ mm}$$

$$\begin{aligned} M_{u \text{ lim}} &= 0.36 f_{ck} b x_{u \text{ lim}} (d - 0.42 x_{u \text{ lim}}) \\ &= 0.36 \times 20 \times 250 \times 216 (450 - 0.42 \times 216) \\ &= 139.688 \times 10^6 \text{ N-mm} \end{aligned}$$

i.e. $M_u < M_{u \text{ lim}}$

Hence it can be designed as singly reinforced section. From the expression

$$M_u = 0.87 f_y A_{st} d \left[1 - \frac{A_{st} f_y}{bd f_{st}} \right], \text{ we get}$$

$$94.5 \times 10^6 = 0.87 \times 415 \times A_{st} \times 450 \left[1 - \frac{A_{st}}{250 \times 450} \times \frac{415}{20} \right]$$

$$581.637 = A_{st} \left[1 - \frac{A_{st}}{5421.686} \right]$$

$$\text{i.e., } A_{st}^2 - 5421.686 A_{st} + 581.637 \times 5421.686 = 0$$

$$\begin{aligned} A_{st} &= \frac{5421.686 - \sqrt{5421.686^2 - 4 \times 581.637 \times 5421.686}}{2} \\ &= 663 \text{ mm}^2 \end{aligned}$$

Provide 4 bars of 16mm diameter.

$$A_{st} \text{ provided} = 4 \times \frac{\pi}{4} \times 16^2 = 804 \text{ mm}^2$$

$$p_t = \frac{804}{250 \times 450} \times 100 = 0.715$$

Design of Shear Reinforcement

$$\tau_v = \frac{V_u}{bd} = \frac{63 \times 1000}{250 \times 450} = 0.56 \text{ N/mm}^2$$

Since $p_t = 0.715$, from table 19 in IS 456,
 $\tau_c = 0.55 \text{ N/mm}^2$

τ_c is very close to τ_v . Hence provide nominal stirrups of 2 legged 6mm at 300 mm c/c.
 Check for Deflection:

$$p_t = 0.714$$

$$f_s = 0.58 \times 415 \times \frac{663}{804} = 198.48 \text{ N/mm}^2$$

From Fig. 4 in IS 456,

$$F_1 = 1.4$$

$$F_2 = 1 \quad \text{and} \quad F_3 = 1$$

Basic $\frac{L}{d} = 7$

$$\begin{aligned} \therefore \frac{L}{d} \text{ max} &= F_1 F_2 F_3 7 \\ &= 1.4 \times 1 \times 1 \times 7 = 9.8 \end{aligned}$$

$$\frac{L}{d} \text{ provided} = \frac{3000}{450} = 6.667 < \frac{L}{d} \text{ max}$$

Hence deflection control is satisfactory.

Anchorage Length

Anchorage length required from the face of support:

$$L_d = \frac{0.87 f_y \phi}{4 \tau_{bd}}$$

From clause 26.2.1.1, design bond strength for
 Fe 415 steel and M20 concrete is

$$\tau_{bd} = 1.2 \times 1.6 = 1.92 \text{ N/mm}^2$$

$$\therefore L_d = \frac{0.87 \times 415 \times 16}{4 \times 1.92} = 752 \text{ mm}$$

Reinforcement details are shown in Fig. 6.13

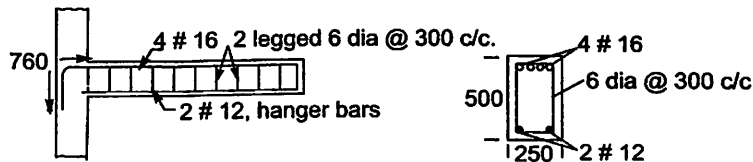

Fig. 6.13.

(ii) If Slab is Flushed with Bottom of Beams (inverted beam case)

In cantilevers compression is in bottom portion. Hence when slab is flushed with bottom of beam, the beam behaves as flanged beam. In case of cantilevers the term l_o , the distance between the two points of zero moment is indefinite. Hence let us take width of flange as

$\frac{L_1 + L_2}{2} + b_w$, i.e. the distance between the centres of adjacent slabs. Thus in this case,

$$b_f = 2.5 \text{ m} = 2500 \text{ mm}$$

The section selected is as shown in Fig. 6.14

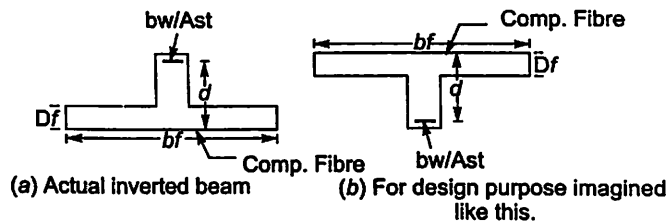

Fig. 6.14.

$M_{u\text{lim}}$ of this beam is definitely more than $M_{u\text{lim}}$ of previous case, since apart from web, flange also contributes in resisting moment.

Hence this section also can be designed as singly reinforced section.

If $x_u = D_f = 120 \text{ mm}$

$$\begin{aligned} M'_u &= 0.36 f_{ck} b_f D_f (d - 0.42 D_f) \\ &= 0.36 \times 20 \times 2500 \times 120 (450 - 0.42 \times 120) \\ &= 863.136 \times 10^6 \text{ N-mm} \end{aligned}$$

Thus $M_u < M'_u$

\therefore Neutral axis is within the flange.

Equating moment to moment of resistance, we get

$$94.5 \times 10^6 = 0.87 \times 415 \times Ast \times 450 \left[1 - \frac{Ast}{2500 \times 450} \times \frac{415}{20} \right]$$

$$581.637 = Ast \left[1 - \frac{Ast}{54216.85} \right]$$

$$Ast^2 - 54216.85 Ast + 581.637 \times 54216.85 = 0$$

$$\begin{aligned} Ast &= \frac{54216.85 - \sqrt{54216.85^2 - 4 \times 581.637 \times 54216.85}}{2} \\ &= 580 \text{ mm}^2 \end{aligned}$$

Provide 3 bars of 16mm diameter.

Design for shear reinforcement, check for deflection control and calculations for anchorage length are same as in case (i).

The cross sectional detail for this case is shown in Fig. 6.15

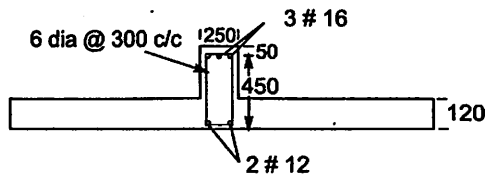

Fig. 6.15. The cross sectional details of inverted cantilever beam.

6.12 DESIGN OF CONTINUOUS BEAMS

In the design of continuous beams the following points are to be noted:

- (i) Effective span is centre to centre distance of supports, except at end spans.
- (ii) Effective depth may be taken as $\frac{1}{15}$ th to $\frac{1}{20}$ th span
- (iii) The critical sections for the design are usually at supports and in the mid spans.
- (iv) It needs rigorous structural analysis to get design moments and shear forces. However, IS 456, 2000 permits (clause 22.5.1) use of design coefficients shown in table 6.2 and 6.3, (table 12 and 13 in IS 456) subject to conditions.
 - (a) There are 3 or more spans.
 - (b) Spans do not differ by 15 per cent of the longest.
 - (c) loads are predominantly uniformly distributed.

Table 6.2 Bending Moment Coefficients [Table 12 of IS 456]

Type of Load	Span Moment		Support Moment	
	Near middle of end span	At middle of interior span	At support next to the end support	At other interior supports
Dead load and imposed load (fixed)	$\frac{1}{12}$	$\frac{1}{16}$	$-\frac{1}{10}$	$-\frac{1}{12}$
Imposed load (not fixed)	$\frac{1}{10}$	$\frac{1}{12}$	$-\frac{1}{9}$	$-\frac{1}{9}$

Note: For obtaining bending moment, the coefficient shall be multiplied by the total design load and effective span.

Table 6.3 Shear Force Coefficient [Table 13 of IS 456]

Type of Load	At end support	At support next to end support		At all other interior supports
		Out or side	Inner side	
Dead load and imposed load (fixed)	0.4	0.6	0.55	0.5
Imposed load (not fixed)	0.45	0.6	0.6	0.6

Note: For obtaining the shear force, the coefficient shall be multiplied by the total design load.

- (v) The reinforcement may be varied to take care of varying moment.

Example 6.6. Design a continuous rectangular beam of spans 7m to carry a dead load of 12 kN/m and a live load of 16 kN/m. The beam is continuous over more than 3 spans and is supported by columns. Use M20 concrete and Fe 415 steel.

Solution.

$$L = 7 \text{ m} \quad w_d = 12 \text{ kN/m} \quad w_L = 16 \text{ kN/m}$$

$$f_{ck} = 20 \text{ N/mm}^2 \quad f_y = 415 \text{ N/mm}^2$$

Cross Sectional Dimension

$$d = \frac{1}{15} \text{ th to } \frac{1}{20} \text{ th of } 7000$$

Let

$$d = 450 \text{ mm}$$

$$D = 500 \text{ mm}$$

$$b = 250 \text{ mm}$$

Design Moment M_u and Design Shear V_u

Self weight of beam = $0.25 \times 0.5 \times 25 = 3.125 \text{ kN/m}$

Dead load = 12 kN/m

Finishing load = 0.875 kN/m

Total $w_d = 16 \text{ kN/m}$

Live load $w_L = 16 \text{ kN/m}$

$\therefore w_{ud} = 1.5 \times 16 \text{ kN/m}$

$w_{uL} = 1.5 \times 16 \text{ kN/m}$

The moment is maximum at support next to end support. Using the table 12 of IS Code

$$M_u = \frac{1.5 \times 16 \times 7^2}{10} + \frac{1.5 \times 16 \times 7^2}{9} = 248.267 \text{ kN-m}$$

Moment at mid span = $\frac{1.5 \times 16 \times 7^2}{12} + \frac{1.5 \times 16 \times 7^2}{10} = 215.6 \text{ kN-m}$

Maximum shear force occurs at outer side of support next to end support (see table 13 of IS 456)

$$V_u = 1.5 \times 16 \times 0.6 \times 7 + 1.5 \times 16 \times 0.6 \times 7$$

$$= 201.6 \text{ kN}$$

Design of Longitudinal Reinforcement

Since it is Fe 415 steel,

$$x_{u \text{ lim}} = 0.48 d = 0.48 \times 450 = 216 \text{ mm}$$

$$M_{u \text{ lim}} = 0.36 f_{ck} b x_{u \text{ lim}} (d - 0.42 x_{u \text{ lim}})$$

$$= 0.36 \times 20 \times 250 \times 216 (450 - 0.42 \times 216)$$

$$= 139.688 \times 10^6 \text{ N-mm}$$

$M_u > M_{u \text{ lim}}$. Hence doubly reinforced section is to be designed.

$$0.87 f_y A_{st1} (d - 0.42 x_{u \text{ lim}}) = 139.688 \times 10^6$$

$$0.87 \times 415 A_{st1} (450 - 0.42 \times 216) = 139.689 \times 10^6$$

$$A_{st1} = 1077 \text{ mm}^2$$

Equating moment of resistance offered by forces in compressions steel and addition tensile steel, we get,

$$0.87 f_y A_{st2} (d - d') = M_u - M_{u \text{ lim}}$$

$$0.87 \times 415 A_{st2} (450 - 50) = (248.267 - 139.688) \times 10^6$$

$$\therefore A_{st2} = 752 \text{ mm}^2$$

$$A_{st} = A_{st1} + A_{st2} = 1077 + 752 = 1829 \text{ mm}^2$$

Since strain varies linearly, we get

$$\epsilon_{sc} = \frac{216 - 50}{216} \times 0.0035 = 2.6898 \times 10^{-3}$$

$$\therefore f_{sc} = 0.83 \times 415$$

Equating compressive force in steel to tensile force in additional steel, we get

$$0.83 \times 415 A_{sc} = 0.87 \times 415 \times 752$$

$$A_{sc} = 788 \text{ mm}^2$$

Provide 6 of 20mm bars in tension zone and 3 of 20 mm bars in compression zone.

At mid span

$$M_u = 215.6 \text{ kN-m} > M_{u \text{ lim}}$$

$\therefore A_{st1}$ is same as at support section *i.e.*

$$A_{st1} = 1077 \text{ mm}^2$$

$$0.87 \times 415 A_{st2} (450 - 50) = (215.6 - 139.688) \times 10^6$$

$$A_{st2} = 525 \text{ mm}^2$$

$$f_{sc} = 0.83 \times 415 \text{ in this case also}$$

$$\therefore 0.83 \times 415 \times A_{sc} = 0.87 \times 415 \times 525$$

$$A_{sc} = 550 \text{ mm}^2$$

$$\therefore A_{st} = 1077 + 525 = 1502 \text{ mm}^2$$

$$A_{sc} = 550 \text{ mm}^2$$

Provide 6 bars of 20 mm diameter in tension zone and 2 bars 20 mm diameter in compression zone.

Shear Reinforcement

$$V_u = 201.6 \text{ kN} = 201600 \text{ N.}$$

$$\tau_v = \frac{201600}{250 \times 450} = 1.792$$

$$p_t = \frac{6 \times \frac{\pi}{4} \times 20^2}{450 \times 450} \times 100 = 1.676$$

$\therefore \tau_c$ from table 19 in IS 456 is

$$\tau_c = 0.74 \text{ N/mm}^2$$

$$V_{us} = V_u - \tau_c b d$$

$$\therefore V_{us} = 201600 - 0.74 \times 250 \times 450 = 118350 \text{ N}$$

From the formula,

$$V_{us} = \frac{0.87 f_y A_{sv} d}{S_v}$$

and using 2 legged 8mm stirrups, we have

$$118350 = \frac{0.87 \times 415 \times \frac{\pi}{4} \times 8^2 \times 450}{S_v}$$

∴ $S_v = 137.2 \text{ mm}$

Provide 2 legged 8 mm stirrups at 130 mm c/c.

Check for Deflection

$$\frac{L}{d} \text{ basic} = 26$$

From Fig 4. in IS 456 for $p_t = 1.676, F_1 = 0.9$

$$F_s = 0.58 \times 415 \times \frac{A_{st \text{ required}}}{A_{st \text{ provided}}} = 240$$

$$p_c = \frac{3 \times \frac{\pi}{4} \times 20^2}{250 \times 450} \times 100 = 0.837$$

From Fig. 5 in IS 456,

$$F_2 = 1.23$$

From Fig. 6,

$$F_3 = 1$$

∴ $\frac{L}{d} \text{ max} = 0.9 \times 1.23 \times 1 \times 26 = 28.78$

$$\frac{L}{d} \text{ provided} = \frac{7000}{450} = 15.55 < \frac{L}{d} \text{ max}$$

Hence deflection control is satisfactory

Reinforcement Details:

It is shown in Fig. 6.16

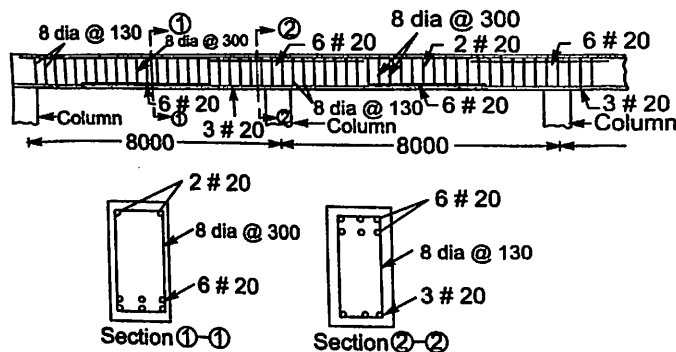

Fig. 6.16.

6.13 DESIGN OF BEAMS SUBJECTED TO TORSION

Circular beams of water tanks, balcony beams etc. are the common examples of beams subjected to torsion. Such beams are associated with bending and shear also. Let the section be subjected to

M_u = ultimate bending moment

T_u = ultimate twisting moment and

V_u = ultimate shear force

As discussed in Chapter IV, as per IS code, equivalent shear and bending moment is given by

$$V_e = V_u + 1.6 \frac{T_u}{b}$$

$$M_e = M_u + T_u \left(1 + \frac{D}{b} \right) \frac{1}{1.7}$$

The section is to be designed to resist V_e and M_e .

IS code recommends the following additional requirements:

(i) If the numerical value of $T_u \left(1 + \frac{D}{b} \right) \frac{1}{1.7}$ exceeds M_u , the longitudinal reinforcement shall be provided on the compression side also. The design moment for this is

$$M_{e2} = M_t - M_u \text{ (numerically)}$$

where $M_t = T_u \left(1 + \frac{D}{b} \right) \frac{1}{1.7}$

(ii) Minimum requirement for stirrups is enhanced to,

$$A_{sv} = \frac{T_u S_v}{b_1 d_1 0.87 f_y} + \frac{V_u S_v}{2.5 d_1 0.87 f_y}$$

where b_1 = Centre to centre distance between compression bars in the direction of width

d_1 = Centre to centre distance between corner bars as shown in Fig. 6.17.

But, the total reinforcement shall not be less than

$$\frac{(\tau_{vc} - \tau_c) b S_v}{0.87 f_y}$$

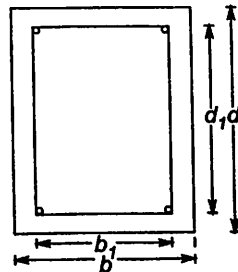

Fig. 6.17

(iii) The spacing of stirrups shall not exceed any of the following (clause 26.5.1.7)

(a) x_1

(b) $\frac{x_1 + y_1}{4}$

(c) 300 mm.

where x_1 and y_1 are short and long dimensions of stirrups. Thus

$$x_1 = b_1 + \phi$$

$$y_1 = d_1 + \phi$$

where ϕ is diameter of stirrups.

(iv) There should be at least one longitudinal bar placed at each corner of the stirrups. When the cross sectional dimension exceeds 450 mm, additional longitudinal bars should be provided on side faces as specified below (clause 26.5.1.7 in IS 456):

Minimum 0.1 per cent of the web area and shall be distributed equally on two faces at a spacing 300 mm or web thickness whichever is less. Typical side face reinforcement is as shown in Fig. 6.18.

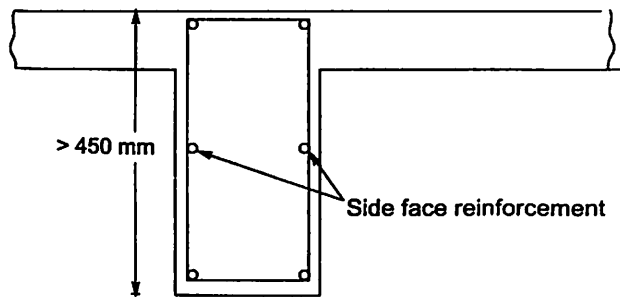

Fig. 6.18.

The design procedure is illustrated with example below:

Example 6.7. Design the reinforcements required for a rectangular beam section with following data:

Size of the beam	— 300 mm × 600 mm.
Grade of Concrete	— M20
Grade of Steel	— Fe 415
Factored shear force	$V_u = 95$ kN
Factored torsional moment	$T_u = 45$ kN-m
Factored bending moment	$M_u = 115$ kN-m.
Sketch the reinforcement details	

Solution.

Assuming 50 mm effective cover,

$$d = 600 - 50 = 550 \text{ mm}$$

$$M_t = \frac{T_u(1 + D/b)}{1.7} = 45 \frac{(1 + 600/300)}{1.7}$$

$$= 79.41 \text{ kN-m}$$

$M_t < M_u$. Hence no need to provide steel on compression side.

$$M_e = M_u + M_t = 115 + 79.41 = 194.41 \text{ kN-m}$$

$$V_e = V_u + 1.6 \frac{T_u}{b} = 95 + 1.6 \frac{45}{0.30} = 335 \text{ kN}$$

Design of Longitudinal reinforcement

$$x_{u \text{ lim}} = 0.48 d = 0.48 \times 550 = 264 \text{ mm.}$$

$$\begin{aligned} \therefore M_{u \text{ lim}} &= 0.36 f_{ck} b x_{u \text{ lim}} (d - 0.42 x_{u \text{ lim}}) \\ &= 0.36 \times 20 \times 300 \times 264 (550 - 0.42 \times 264) \\ &= 250.40 \times 10^6 \text{ N-mm} = 250.4 \text{ kN-m.} \end{aligned}$$

$M_e < M_{u \text{ lim}}$. Hence singly reinforced section can be designed.

\therefore Tensile reinforcement A_{st} is given by

$$M_e = 0.87 f_y A_{st} d \left[1 - \frac{A_{st} f_y}{bd f_{ck}} \right]$$

$$194.41 \times 10^6 = 0.87 \times 415 A_{st} \times 550 \left[1 - \frac{A_{st}}{300 \times 550} \frac{415}{20} \right]$$

$$979.013 = A_{st} \left[1 - \frac{A_{st}}{7951.807} \right]$$

$$A_{st}^2 - 7951.807 A_{st} + 979.013 \times 7951.807 = 0$$

$$A_{st} = \frac{7951.807 - \sqrt{7951.807^2 - 4 \times 979.013 \times 7951.807}}{2} = 1144 \text{ mm}^2$$

Provide 4 bars of 20 mm diameter.

$$A_{st} \text{ provided} = 4 \times \frac{\pi}{4} \times 20^2 = 1256 \text{ mm}^2.$$

Design of Shear reinforcement

$$\tau_{ve} = \frac{335 \times 1000}{300 \times 550} = 2.03 \text{ N/mm}^2.$$

$$p_t = \frac{1256}{300 \times 550} \times 100 = 0.76$$

From table 19 of IS 456,

$$\tau_c = 0.56 \text{ N/mm}^2.$$

From Table 20 of IS 456,

$$\tau_{c \text{ max}} = 2.8 \text{ N/mm}^2.$$

Thus $\tau_c < \tau_v < \tau_{c \text{ max}}$

Hence shear reinforcement is to be provided.

$$\begin{aligned} V_{us} &= V_u - \tau_c b d \\ &= 335 \times 1000 - 0.56 \times 300 \times 550 \\ &= 242600 \text{ N} \end{aligned}$$

Selecting 2 legged 8 mm HYSD bars for shear reinforcement.

$$V_{us} = \frac{0.87 f_y A_{sv} d}{S_v} \text{ gives.}$$

$$242600 = \frac{0.87 \times 415 \times 2 \times \frac{\pi}{4} \times 8^2 \times 550}{S_v}$$

or $S_v = 82.29$ mm.

Spacing is too close, creating problems in concreting. Hence provide 4 legged stirrups at 160 mm ($< 2 \times 82.29$) centre to centre.

Check for minimum reinforcement: Assuming 50 mm side cover

$$b_1 = 300 - 100 = 200 \text{ mm.}$$

$$d_1 = 600 - 100 = 500 \text{ mm.}$$

$$\begin{aligned} \therefore A_{sv} \text{ minimum} &= \frac{T_u S_v}{b_1 d_1 0.87 f_y} + \frac{V_u S_v}{2.5 d_1 0.87 f_y} \\ &= \frac{45 \times 10^6 \times 160}{200 \times 500 \times 0.87 \times 415} + \frac{95000 \times 160}{2.5 \times 500 \times 0.87 \times 415} = 233 \text{ mm}^2. \end{aligned}$$

$$A_{sv} \text{ provided} = 4 \times \frac{\pi}{4} \times 8^2 = 201 \text{ mm}^2 < A_{sv} \text{ reqd.}$$

Reduce the spacing to 150 mm. Then

$$A_{sv} \text{ minimum} = 233 \times \frac{150}{160} = 194 \text{ mm}^2 < A_{sv} \text{ provided.}$$

The maximum spacing requirement is

$$x_1 = 200 + 8 = 208 \text{ mm.}$$

$$\frac{x_1 + y_1}{4} = \frac{208 + 508}{4} = 179 \text{ mm.}$$

or

By selecting $S_v = 150$ mm this requirement is also satisfied. Hence 2 legged 8 mm stirrups at 150 mm c/c is satisfactory.

Side face reinforcement

$d_1 > 450$ mm. Hence side face reinforcement is required.

$$0.1\% \text{ of web area} = \frac{0.1 \times 300 \times 600}{100} = 180 \text{ mm}^2$$

$$\text{Reinforcement required on each face} = \frac{180}{2} = 90 \text{ mm}^2$$

Hence provide 1 bar of 12 mm on each face as shown in Fig. 6.19

$$\text{Area provided} = \frac{\pi}{4} \times 12^2 = 113 \text{ mm}^2$$

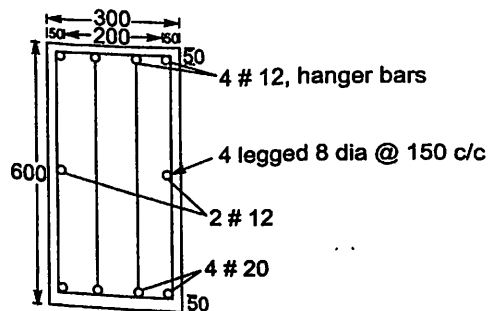

Fig. 6.19

6.14 CURTAILMENT OF TENSION REINFORCEMENT IN FLEXURAL MEMBERS

Tension reinforcement is designed for sections where moment (+ve or -ve) is maximum. But we know moment varies from section to section depending upon the loading and support conditions. Hence tension reinforcement need not be taken to entire length of beam. Some of them may be curtailed, where bending resistance can be offered by remaining bars.

We know the moment of resistance is given by $M_u = 0.87 f_y A_{st} (d - 0.42x_u)$ in singly reinforced sections. It means, if the same section is maintained throughout A_{st} required is directly proportional to bending moment. If we decide to curtail n_1 number of bars out of n bars, then the bending moment at the section should not be more than

$$M_{u1} = \frac{n - n_1}{n} M_u$$

The section may be located where moment is equal to M_{u1} . However this is the theoretical section. SP-34, Hand book on concrete reinforcement and detailing specifies:

- (i) Bars shall extend beyond the point of theoretical cut off for a distance equal to the effective depth of the member or 12 times the bar diameter, whichever is more.
- (ii) At least one-third the maximum positive moment reinforcement in simple members and one-fourth the maximum positive moment reinforcement in continuous members shall extend along the same face of the member into the support for a length equal to $\frac{L_d}{3}$
- (iii) Minimum 2 bars should extend throughout.
- (iv) At least one third of the total negative moment reinforcement shall extend beyond the point of inflection by 12 times the diameter of the bar or one-sixteenth of the clear span, whichever is greater.

For more details designers may refer to SP-36 clauses 4-6 published by Bureau of Indian Standards.

- (v) When bars for +ve reinforcement are curtailed shear strength of concrete near support reduces. This reduced strength of shear should be carefully noted and reinforcement is designed.

Questions

1. A rectangular beam 200 mm wide and 350 mm deep upto the centre of reinforcement, has to resist a factored moment of 40 kN-m. Design the section. Use M 20 Concrete and Fe 415 steel.
2. A T-beam slab floor of R.C.C. has 150 mm thick slab forming part of T-beam which are of 10m clear span. The end bearings are 450 mm thick. Spacing of T-beam is 3 m. The live load on the floor is 4 kN/m². Design one of the T-beams using limit state method. Use M20 concrete and Fe 415 steel.
3. The overall cross section of a R.C. beam is 300 mm × 600 mm. The factored design moment at a particular section of the beam is 330 kN-m. Design the necessary reinforcement by limit state method, if the effective cover to the reinforcement is 35 mm. Adopt M25 concrete and Fe 415 steel.

4. A reinforced concrete T-beam has a flange width of 1000 mm and thickness 120 mm. The web is 250 mm wide and 600 mm deep. Design the T-beam to carry a live load of 20 kN/m over a span of 8m. Use M20 concrete and Fe 415 steel. Sketch the reinforcement details.
5. A rectangular beam of 230 mm \times 450 mm is reinforced with 3 bars of 16 mm diameter. Design the shear reinforcement at the section where shear force of 100 kN is acting.
6. At a particular cross section of R.C. Beam 300mm \times 600mm in size, a factored bending moment of 120 kN-m, a factored shear force of 100 kN and a factored torsion moment of 60 kN-m are acting. Design the necessary reinforcements using M25 concrete and Fe 415 HYSD bars.

Design of Slabs

7.1 INTRODUCTION

Slabs are usually supported on two parallel sides or on all the four sides. Beams or walls are the common supports for slabs. If a slab is supported on two opposite edges, it bends in only one direction as shown in Fig. 7.1. Hence it needs reinforcements in only one direction. However distribution steel is to be provided at right angles to main reinforcement so that load is distributed properly. Apart from this distribution steel helps in distributing secondary stresses like temperature stresses. Hence in slabs reinforcement is always provided in both directions.

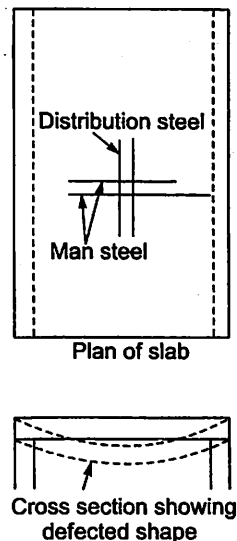

Fig. 7.1. A 'typical' slab supported on two opposite edges.

If the slab is supported on all the four sides, it bends in both directions and needs reinforcements in both directions. Fig. 7.2 shown a typical slab supported on all the four sides with spans l_x in x direction and l_y in y - direction, where x is the direction of shorter side ($l_x \leq l_y$). In such case the reinforcements are to be designed for both directions. However, from the analysis of slabs by plate theory it is found that if the ratio of larger span to smaller span $\left(\frac{l_y}{l_x}\right)$

is more than 2, the bending moment in the direction of larger span is very small. The main reinforcement required works out to be less than that required as distribution steel for one way slab. The bending moment in shorter span is almost equal to bending moment in one way slab and hence the slab may be designed as one way slab if the ratio of large span (l_y) to shorter span (l_x) is more than 2.

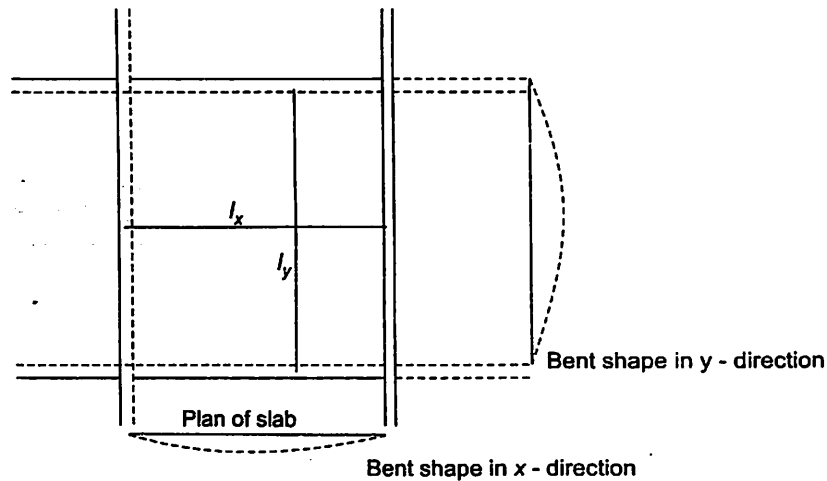

Fig. 7.2. A typical slab supported on all the four sides.

The slabs in which main reinforcement is to be designed in only one direction is called one way slab. If main reinforcement is to be designed in both directions, the slab is called two way slab.

The slab may be simply supported or continuous or may be a cantilever. The bending moments at critical sections are to be found and reinforcements designed. Slab is usually designed as a beam of one metre width to carry moment over a strip of 1 metre. Instead of number of bars, spacing of bars are to be found. 8 mm or 10 mm bars are commonly used. Occasionally 12 mm bars are also used.

7.2 DESIGN OF ONE WAY SIMPLY SUPPORTED SLABS

The procedure for the design of slabs supported on two opposite edges or for the design of slabs supported on all the four edges but with the ratio of larger to shorter span equal to or more than two is as given below:

1. In Simply supported slabs or in beams, to satisfy deflection criteria span to depth ratio is $F_1 \times F_2 \times F_3 \times \text{basic value}$. The basic value in simply supported case is 20. Usually F_1 , the factor to account for tensile reinforcement works out to be more than 1.25. In slabs compression steel is normally avoided and the section are to be designed as rectangular. Hence the factors F_2 and F_3 are unity. Therefore to satisfy deflection criteria, span to depth ratio $\frac{l}{d} \geq 25$. So the depth of slab may be taken as $\frac{1}{25}$ span.

2. Find the factored moment M_u in 1 m width of slab.
3. Determine $M_{u \text{ lim}}$ for 1000 mm wide slab. If $M_u < M_{u \text{ lim}}$, design the singly reinforced section. If $M_u > M_{u \text{ lim}}$, increase the depth and design singly reinforced section. In the

design effective depth may be taken as D – effective cover. Nominal cover may be reduced by 5 mm (table 16 – IS 456), since the diameter of bars used is less than 12 mm.

4. The required area of steel A_{st} is to be provided in 1000 mm width. Instead of finding number of bars for 1000 mm width, find, S the spacing of the bars using the following expression.

$$S = \frac{\pi/4 \phi^2}{A_{st}} \times 1000.$$

5. As per clause no. 26.3.3 the spacing should not be more than $3D$ or 300 mm whichever is smaller. Check the value of spacing S and make final choice.

6. **Check for shear in 1000 mm strip:** For this find $\tau_v = \frac{V_u}{bd}$

Clause 40.2.1.1 says for solid slabs, the design shear strength of concrete may be taken as $\tau_c k_s$ where k_s is given by

Over all depth \geq	300	275	250	225	200	175	150	or less
k_s	1.0	1.05	1.10	1.15	1.20	1.25	1.30	

Also note for slabs, nominal shear stress (τ_c) shall not exceed $\frac{1}{2} \tau_{c \max}$, where $\tau_{c \max}$ is as given in table 20 (IS 456). Shear reinforcements in slabs should be avoided, since they work out cumbersome and expensive. Hence, if $\tau_v > \tau_c$, increase the thickness of slab and redesign.

7. Check for Deflection Control

Since F_2 , and F_3 , the modification factors are unity

$$\begin{aligned} \frac{l}{d} \max &= F_1 \times \text{basic value} \\ &= 20 F_1. \end{aligned}$$

Determine F_1 from fig 4 in IS 456.

$\frac{l}{d}$ provided should be less than $\frac{l}{d} \max$. If this criteria is not satisfied either redesign by increasing d or calculate deflections and get satisfied with the values.

8. Distribution Steel (Clause 26.5.2.1 in IS 456)

A minimum of 0.15 percent of total cross section if mild steel is used or 0.12 per cent of total cross section if Fe 415 is used, as required as distribution steel. Thus if, Fe 415 is used.

$$A_{st} = \frac{0.12}{100} bD$$

Hence spacing of distribution steel is given by

$$S = \frac{\pi/4 \phi^2}{A_{st}} \times 1000 \text{ mm.}$$

where ϕ is diameter of distribution steel. For the simplicity in construction usually ϕ is taken same as for main bars. However smaller diameter of bars also may be used.

Example 7.1. A hall has clear dimension 3 m \times 9 m. with wall thickness 230 mm. The live load on the slab is 3 kN/m² and a finishing load of 1 kN/m² may be assumed. Using M20 grade concrete and Fe 415 grade steel, design the slab.

Solution.

$$\frac{l_y}{l_x} = \frac{9}{3} = 3 > 2$$

Hence it will be designed as one way slab.

Depth of Slab:

$$\frac{1}{25} \text{ span} = \frac{1}{25} \times 3000 = 120 \text{ mm}$$

Let us select

$$d = 125 \text{ mm}$$

and

$$D = 150 \text{ mm}$$

Bending Moment and Shear Force per metre width of slab:

Loads:

$$DL = 0.15 \times 1 \times 1 \times 25 = 3.75 \text{ kN/m.}$$

Finishing load

$$= 1 \text{ kN/m}$$

Live load

$$= 3 \text{ kN/m}$$

$$\text{Total} = 7.75 \text{ kN/m}$$

∴

$$w_u = 1.5 w = 1.5 \times 7.75 \text{ kN/m}$$

Effective span is smaller of the following two.

$$(i) 3000 + d = 3000 + 125 = 3125 \text{ mm} = 3.125 \text{ m}$$

$$(ii) 3000 + w = 3000 + 230 = 3230 \text{ mm} = 3.230 \text{ m}$$

∴

$$l = 3.125 \text{ m}$$

∴

$$M_u = w_u \frac{l^2}{8} = 15 \times 7.75 \times \frac{3.125^2}{8} = 14.19 \text{ kN-m}$$

$$V_u = w_u \frac{l}{2} = 15 \times 7.75 \times \frac{3.125}{2} = 18.164 \text{ kN.}$$

Design for M_u :

$$x_{u \text{ lim}} = 0.48 d = 0.48 \times 125 = 60 \text{ mm}$$

$$M_{u \text{ lim}} = 0.36 f_{ck} b x_{u \text{ lim}} (d - 0.42 x_{u \text{ lim}})$$

$$= 0.36 \times 20 \times 1000 \times 60 (125 - 0.42 \times 60)$$

$$= 43.114 \times 10^6 \text{ N-mm}$$

$$= 43.114 \text{ kN-m.}$$

$$M_u < M_{u \text{ lim}}$$

∴ singly reinforced section can be designed.

$$M_u = 0.87 f_y A_{st} d \left\{ 1 - \frac{A_{st} f_y}{bd f_{ck}} \right\}, \text{ gives}$$

$$14.19 \times 10^6 = 0.87 \times 415 A_{st} 125 \left[1 - \frac{A_{st}}{1000 \times 125} \times \frac{415}{20} \right]$$

$$314.416 = A_{st} \left[1 - \frac{A_{st}}{60241} \right]$$

$$\text{or } Ast^2 - 6024.1 A_{st} + 314.416 \times 6024.1 = 0$$

$$A_{st} = \frac{6024.1 - \sqrt{6024.1^2 - 4 \times 314.416 \times 6024.1}}{2}$$

$$= 333 \text{ mm}^2.$$

Main Reinforcement:

Using 10 mm bars, spacing

$$S = \frac{\pi/4 \times 10^2}{333} \times 1000 = 235.8 \text{ mm.}$$

Hence provide 10 mm bars at 225 mm c/c.

Check for Maximum Spacing:

$$(i) S_{\max} = 3d = 3 \times 125 = 375 \text{ mm}$$

$$(ii) 300 \text{ mm}$$

The spacing provided is satisfactory.

Check for Shear:

$$\tau_v = \frac{V_u}{bd} = \frac{18164 \times 1000}{1000 \times 125} = 0.415 \text{ N/mm}^2$$

$$p_t = \frac{\pi/4 \times 10^2}{225 \times 125} \times 100 = 0.279$$

τ_c for beams (from table 19 in IS 456)

$$= 0.375 \text{ N/mm}^2$$

\therefore For slabs

$$\tau_c = 1.3 \times 0.375 = 0.487 \text{ N/mm}^2$$

Now

$$\tau_v < \tau_c \text{ and also. } \tau_v < 0.5 \tau_{c \max}$$

Hence slab is safe in shear.

Check for Deflection Control:

$$p_t = 0.279$$

$$f_s = 0.58 \times 415 = 240.7 \text{ N/mm}^2$$

From Fig 4 in IS 456,

$$F_1 = 1.50$$

$$\therefore \frac{l}{d} \max = 1.50 \times 20 = 30$$

$$\frac{l}{d} \text{ provided} = \frac{3125}{125} = 25 < \frac{l}{d} \max.$$

\therefore Deflection control is satisfactory.

Distribution Steel:

$$A_s = \frac{0.12 \times bd}{100} = \frac{0.12 \times 1000 \times 125}{100} = 150 \text{ mm}^2$$

Selecting 8 mm bars

$$S = \frac{\pi/4 \times 8^2}{150} \times 1000 = 335 \text{ mm.}$$

Provide 8 mm bars at 300 mm c/c.
 Reinforcement details are shown in Fig. 7.3

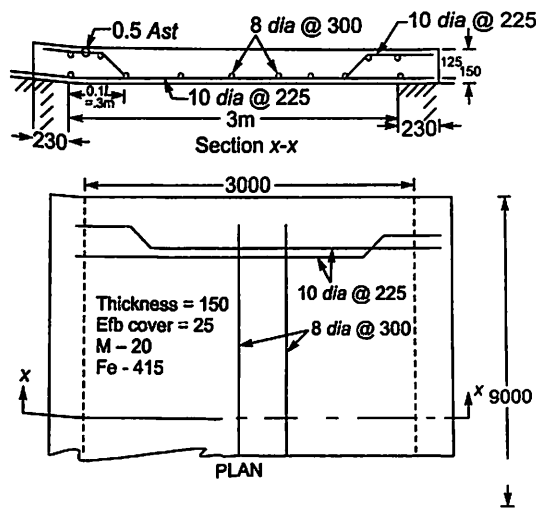

Fig. 7.3

7.3 DESIGN OF CONTINUOUS SLAB

Continuous slabs are subjected to negative moments at supports and to positive moments at mid span. Hence design is required for all critical sections. However to avoid problems in construction, usually design is made for the maximum bending moment and shear force and the reinforcement is provided.

IS 456 (table 12 and 13) gives expressions for finding moments and shear forces at critical sections. These are presented in table 6.2 and 6.3 also. However it may be noted that these coefficients are for beams/slabs of uniform cross sections which supports substantially uniformly distributed loads over 3 or more spans which do not differ by more than 15 per cent of the longest span. For all other cases, rigorous structural analysis is required.

It may be noted that if all spans are equal maximum moment is at support next to end support

$$M_{\max} = \frac{w_d l^2}{12} + \frac{w_L l^2}{9}$$

and V_{\max} is at outer of first interior support

$$V_{\max} = 0.6 w_d + 0.6 w_L$$

Design Procedure:

- (i) Assume a depth of $\frac{l}{30}$ th of span.
- (ii) Effective span shall be found as explained in Art. 6.3 (Clause 222 IS 456).
- (iii) Find design moment and shear force.
- (iv) Design for moment.
- (v) Check for shear.

- (vi) Check for deflection control.
 (vii) Design distribution steel.
 (viii) Sketch reinforcement details.

Example 7.2. Design a continuous R.C. slab for a class room 7 m wide and 14 m long. The roof is to be supported on R.C.C. beams spaced at 3.5 m intervals. The width of beam should be kept 230 mm. The superimposed load is 3 kN/m² and finishing load expected is 1 kN/m². Use M20 concrete and Fe 415 steel.

Solution.

Depth of Slab

$$\frac{\text{Span}}{30} = \frac{3500}{30} = 116.67 \text{ mm}$$

Let $d = 120 \text{ mm}$ and $D = 150 \text{ mm}$

Effective Span

Width of support = 230 mm

Clear span = 3500 – 230 = 3270 mm

$$\therefore \frac{l}{12} \text{ th clear span} = \frac{3270}{12} = 272.5 \text{ mm}$$

Thus width of support < $\frac{l}{12}$ th clear span.

$$\begin{aligned} \therefore \text{Effective span} &= 3270 + 120 = 3390 \text{ mm} \\ &= 3.39 \text{ m} \end{aligned}$$

Design Moment and Shear for 1 m wide Slab

Self wt of slab = 0.15 × 1 × 1 × 25 = 3.75 kN/m²

Finishing load = 1 kN/m²

Total DL = 4.75 kN/m²

Superimposed load = 3 kN/m²

Maximum moment occurs at support next to the end support and is given by

$$M_u = \frac{1.5 \times 4.75 \times 3.39^2}{10} + 1.5 \times 3 \times \frac{3.39^2}{9} = 13.93 \text{ kN-m.}$$

Maximum shear force occurs at outer side of the support next to end support and is given by

$$V_u = 0.6 \times 1.5 \times 4.75 \times 3.39 + 0.6 \times 1.5 \times 3 \times 3.39 = 23.65 \text{ kN.}$$

Design of Main Reinforcement:

$$x_{u \text{ lim}} = 0.48 \times 120 = 57.6 \text{ mm}$$

$$\begin{aligned} \therefore M_{u \text{ lim}} &= 0.36 f_{ck} b x_{u \text{ lim}} (d - 0.42 x_{u \text{ lim}}) \\ &= 0.36 \times 20 \times 1000 \times 57.6 (120 - 0.42 \times 57.6) \\ &= 39.733 \times 10^6 \text{ N-mm.} \end{aligned}$$

$$\therefore M_u < M_{u \text{ lim}}$$

Hence singly reinforced section can be designed.

From the relation.

$$M_u = 0.87 f_y A_{st} d \left(1 - \frac{A_{st} f_y}{bd f_{ck}} \right), \text{ we get}$$

$$13.93 \times 10^6 = 0.87 \times 415 \times A_{st} \times 120 \left(1 - \frac{A_{st}}{1000 \times 120} \times \frac{415}{20} \right)$$

$$\text{i.e.,} \quad 321.516 = A_{st} \left(1 - \frac{A_{st}}{5783.13} \right)$$

$$\text{i.e. } A_{st}^2 - 5783.13 A_{st} + 321.516 \times 5783.13 = 0$$

$$A_{st} = \frac{5783.13 - \sqrt{5783.13^2 - 4 \times 321.516 \times 5783.13}}{2}$$

$$= 341.7 \text{ mm}^2$$

Using 10 mm bars,

$$S = \frac{\pi/4 \times 10^2}{341.7} \times 1000 = 229 \text{ mm}$$

Provide 10 mm bars at 225 mm c/c

$$\therefore A_{st} \text{ provided} = \frac{\pi/4 \times 10^2}{225} \times 1000 = 349 \text{ mm}^2$$

Maximum spacing permitted is 3×120 or 300, whichever is less. Hence this requirement is satisfied.

Check for Shear:

$$p_t = \frac{\pi/4 \times 10^2}{225 \times 120} \times 100 = 0.291$$

From table 19 in IS 456,

$$\tau_c = 0.38$$

Since slab thickness is less than 150mm, enhance factor $k_s = 1.3$

(Clause 40.2.1.1)

$$\tau_c \text{ for slab} = 1.3 \times 0.38$$

$$= 0.494 \text{ N/mm}^2$$

$$\tau_c = \frac{V_u}{bd} = \frac{23.65 \times 1000}{1000 \times 120} = 0.197 \text{ N/mm}^2$$

$$\tau_c \text{ max} = 0.5 \times 2.8 = 1.4 \text{ N/mm}^2$$

Then $\tau_v < \tau_c$

and $< \tau_c \text{ max}$

\therefore Shear reinforcement is not required.

Check for Deflection Control:

$$\frac{l}{d} \text{ provided} = \frac{3.39 \times 1000}{120} = 28.25$$

For continuous slab basic $\frac{l}{d} = 26$.

$$p_t = 0.291 f_s = 0.58 \times 415 \times \frac{341.7}{349} = 235.7 \text{ N/mm}^2$$

∴ From Fig. 4 in IS 456, $F_1 = 1.55$

$$\therefore \frac{l}{d} \text{ maximum} = 26 \times 1.55 = 40.3$$

$$\frac{l}{d} \text{ provided} < \frac{l}{d} \text{ max.}$$

∴ Deflection control is satisfactory.

Distribution Steel

$$A_s = \frac{0.12 \times 1000 \times 150}{100} = 180 \text{ mm}^2$$

Using 8 mm bars

$$S_v = \frac{\pi/4 \times 8^2}{180} \times 1000 = 279 \text{ mm.}$$

Provide 8 dia @ 270 mm c/c.

(or 6 dia @ 150 mm c/c)

Reinforcement Details

The details are shown in Fig. 7.4.

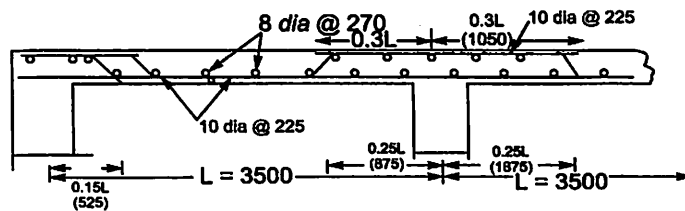

Fig. 7.4. Reinforcement details in one way continuous slab.

7.4 DESIGN OF CANTILEVER SLAB

Common example of cantilever slabs are chajjas and balcony slabs. These slabs are free at one end and may be treated as fixed at other ends to lintel beams. They may be overhanging portions of interior slabs. They need reinforcement at top since in cantilevers subjected to vertical downward loads, tension is on top. Moment is maximum at fixed/continuous end. Hence design is for the section at that end. We know in cantilevers moment reduces to zero at free end. Hence the thickness of cantilever slab may be reduced gradually towards free end. Hence a minimum thickness of 75 mm is maintained at free end.

In the design the following points are to be noted:

(i) For uniformly distributed load $M_u = \frac{w_u L^2}{2}$

and $V_u = w_u L$

(ii) Basic value of $\frac{L}{d}$ for cantilevers = 7.

(iii) Main bars determined are to be provided at top

(iv) There should be check for anchorage length of main bars.

Example 7.3. Design a cantilever balcony slab projecting 1.2 m from a beam. Adopt a live load of 2.5 kN/m^2 . Use M20 concrete and Fe 415 steel.

Solution.

Depth of Slab :

$$d = \frac{1}{7} \text{th span} = \frac{1200}{7} = 171.4 \text{ mm}$$

Use

$$d = 175 \text{ mm and } D = 200 \text{ mm}$$

The depth D may be gradually reduced to 100 mm.

Design Moment (M_u) and Shear (V_u):

Self weight = Average load taken as udl

$$= \frac{0.200 + 0.100}{2} \times 1 \times 1 \times 25 = 3.75 = 3.75 \text{ kN/m}^2$$

Finishing load

$$= 1 \text{ kN/m}^2$$

Live load

$$= 2.5 \text{ kN/m}^2$$

Total load

$$= 7.25 \text{ kN/m}^2$$

Moment and shear per metre width of slab are

$$M_u = \frac{w_u L^2}{2} = 1.5 \times 7.25 \times \frac{1.2^2}{2} = 7.83 \text{ kN-m}$$

$$V_u = w_u L = 1.5 \times 7.25 \times 1.2 = 13.05 \text{ kN.}$$

Design of Main Reinforcement

$$x_{u \text{ lim}} = 0.48 d = 0.48 \times 175 = 84 \text{ mm}$$

$$M_{u \text{ lim}} = 0.36 f_{ck} b x_{u \text{ lim}} (d - 0.42 x_{u \text{ lim}})$$

$$= 0.36 \times 20 \times 1000 \times 84 (175 - 0.42 \times 84)$$

$$= 84.50 \times 60^6 \text{ N-mm}$$

$$= 84.5 \text{ kN-m}$$

$$\therefore M_u < M_{u \text{ lim}}$$

\therefore Singly reinforced section can be designed.

From the relation,

$$M_u = 0.87 f_y A_{st} d \left[1 - \frac{A_{st}}{bd} \frac{f_y}{f_{ck}} \right], \text{ we get.}$$

$$7.83 \times 10^6 = 0.87 \times 415 A_{st} \times 175 \left[1 - \frac{A_{st}}{1000 \times 175} \times \frac{415}{20} \right]$$

$$123.924 = A_{st} \left[1 - \frac{A_{st}}{8433.73} \right]$$

$$\text{i.e. } A_{st}^2 - 8433.73 A_{st} + 123.924 \times 84.33.73 = 0.$$

$$A_{st} = \frac{8433.73 - \sqrt{8433.73^2 - 4 \times 123.924 \times 8433.73}}{2} = 125.8 \text{ mm}^2$$

Minimum reinforcement

$$A_s = \frac{0.12}{100} \times bD = \frac{0.12}{100} \times 1000 \times 200 = 240 \text{ mm}^2$$

$$S = \frac{\frac{\pi}{4} \times 8^2}{240} \times 1000 = 209 \text{ mm}$$

∴ Provide 8 mm bars at 200 mm c/c.

Distribution Steel:

$$A_{st} = \frac{0.12}{100} \times 1000 \times 200 = 240$$

i.e. Provide 8 mm bars at 200 mm c/c.

Anchorage Length

$$L_d = \frac{0.87 f_y \phi}{4 \tau_{bd}} = \frac{0.87 \times 415 \times 10}{4 \times 1.2 \times 1.6} = 376 \text{ mm}$$

Provide it as shown in Fig. 7.5

Check Deflection control:

$$\frac{L}{d} \text{ Provided} = \frac{1200}{175} = 6.857$$

$$\text{Basic } \frac{L}{d} = 7.$$

$$p_t = \frac{\frac{\pi}{4} \times 8^2}{200 \times 200} \times 100 = 0.196$$

$$f_s = 0.58 \times 415 \times \frac{\text{Area reqd.}}{\text{Area provided}} = 240$$

From Fig. 4 in IS 456,

$$F_1 = 2$$

$$F_2 = F_3 = 1$$

$$\therefore \frac{L}{d} \text{ max} = 2.0 \times 1 \times 1 \times 7 = 14$$

Thus $\frac{L}{d}$ provided $<$ $\frac{L}{d}$ max.

∴ Deflection control is satisfactory.

Reinforcement details:

It is shown in Fig. 7.5

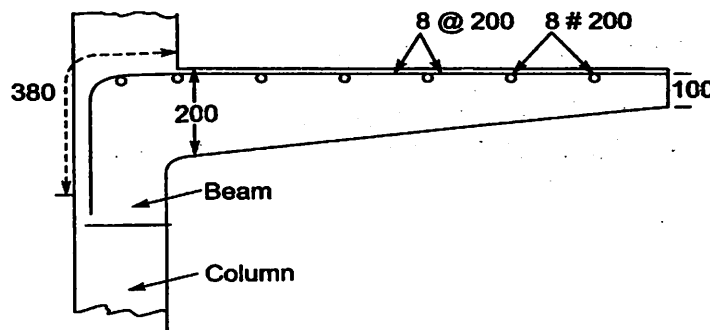

Fig. 7.5. Details of Reinforcement in Balcony slab.

7.5 DESIGN OF TWO WAY SLABS

When slab is supported on all four sides and the ratio of long span (l_y) to short span (l_x) is less than two, the bending moment developed in both x and y directions is predominant and hence design should be made for reinforcements in both directions. For the analysis of such slab various theories have been developed and the expressions for bending moment M_x and M_y presented. Among all those theories plate theory is quite precise.

The moment developed depends upon the edge conditions also. In buildings, we come across the following boundary conditions.

1. All four edges continuous (Interior panels)
2. One short edge discontinuous
3. One long edge discontinuous
4. Two adjacent edges discontinuous
5. Two short edges discontinuous
6. Two long edges discontinuous
7. Three edges discontinuous and one long edge continuous
8. Three edges discontinuous and one short edge continuous
9. Four edges discontinuous but corners held down by providing torsional reinforcements.
10. Simply supported slab without torsional reinforcements.

Note: Simply supported slabs have tendency to lift at corners due to torsional moment in the slab. Lifting of the corners may be prevented by providing torsional reinforcement in the form of two mats. If such precaution is taken, the simply supported slab falls under category 9 otherwise it falls under category 10. The typical slabs are shown in Fig. 7.6.

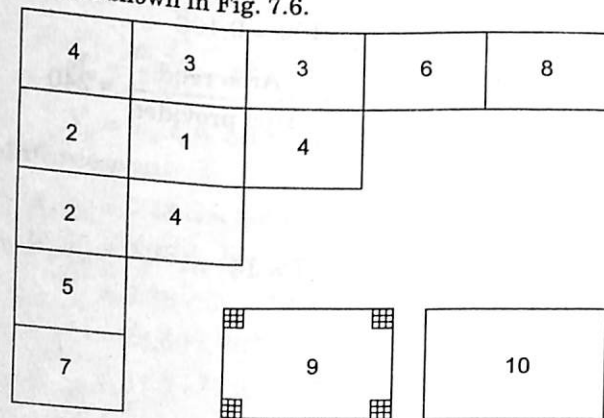

Fig. 7.6. Slabs with different edge conditions.

For uniformly distributed load on entire slab, maximum +ve moment (tension at bottom) develops and at supports -ve moment develops. IS 456 (Annex D, table 26 and 27) give moment coefficient to find +ve and -ve moments developed in slabs with various edge conditions. The maximum bending moment per unit width in a slab are given by

$$M_u = \alpha_x w l_x^2$$

and

$$M_u = \alpha_y w l_y^2$$

where α_x and α_y are the coefficients given in tables

Table 7.1 Bending Moment Coefficient for Rectangular Panels Supported on Four Sides with Provision for Torsion at Corners (Table 26 in IS 456:2000)
[Clauses D-1.1 and 24.4.1]

Case No.	Type of Panel and Moments Considered	Short Span Coefficients α_x (Values of l_y / l_x)								Long Span Coefficients α_y for all Values of l_y / l_x
		(3)	(4)	(5)	(6)	(7)	(8)	(9)	(10)	
(1)	(2)									(11)
1	Interior Panels: Negative moment at continuous edge. Positive moment at mid span	0.032 0.024	0.037 0.028	0.043 0.032	0.047 0.036	0.051 0.039	0.053 0.041	0.060 0.045	0.065 0.049	0.032 0.024
2	One Short Edge Discontinuous: Negative moment at continuous edge Positive moment at mid span	0.037 0.028	0.043 0.032	0.048 0.036	0.051 0.039	0.055 0.041	0.057 0.044	0.064 0.048	0.068 0.052	0.037 0.028
3	One Long Edge Discontinuous: Negative moment at continuous edge Positive moment at mid-span	0.037 0.028	0.044 0.033	0.052 0.039	0.057 0.044	0.063 0.047	0.067 0.051	0.077 0.059	0.085 0.065	0.037 0.028
4	Two Adjacent Edges Discontinuous: Negative moment at continuous edge Positive moment at mid-span	0.047 0.035	0.053 0.040	0.060 0.045	0.065 0.049	0.071 0.053	0.075 0.056	0.084 0.063	0.091 0.069	0.047 0.035
5	Two Short Edges Discontinuous: Negative moment at continuous edge Positive moment at mid-span	0.045 0.035	0.049 0.037	0.052 0.040	0.056 0.043	0.059 0.044	0.060 0.045	0.065 0.049	0.069 0.052	-- 0.035
6	Two Long Edges Discontinuous: Negative moment at continuous edge Positive moment at mid-span	-- 0.035	-- 0.043	-- 0.051	-- 0.057	-- 0.063	-- 0.068	-- 0.080	-- 0.088	0.045 0.035
7	Three Edges Discontinuous (One Long Edge Continuous) Negative moment at continuous edge Positive moment at mid-span	0.057 0.043	0.064 0.048	0.071 0.053	0.076 0.057	0.080 0.060	0.084 0.064	0.091 0.069	0.097 0.073	-- 0.043
8	Three Edges Discontinuous (One short Edge Continuous) Negative moment at continuous edge Positive moment at mid-span	-- 0.043	-- 0.051	-- 0.059	-- 0.065	-- 0.071	-- 0.076	-- 0.087	-- 0.096	0.057 0.043
9	Four Edges Discontinuous Positive moment at mid-span	0.056	0.64	0.072	0.079	0.085	0.089	0.100	0.107	0.056

M_x, M_y – are moments on strips of unit width of span l_x and l_y respectively

l_x and l_y – are length of shorter and longer spans respectively.

The coefficients are given in tables 7.1 and 7.2.

Table 7.2 Bending Moment Coefficient for Slabs Spanning in Two Directions at Right Angles, Simply Supported on Four Sides (Table 27, IS 456 : 2000) [Clause D-2.1]

l_y / l_x	1.0	1.1	1.2	1.3	1.4	1.5	1.75	2.0	2.5	3.0
α_x	0.062	0.074	0.084	0.093	0.099	0.104	0.113	0.118	0.122	0.124
α_y	0.062	0.061	0.059	0.055	0.051	0.046	0.037	0.029	0.020	0.014

IS 456 consider the middle $\frac{3}{4}$ th portion as middle strip and edge $\frac{1}{8}$ th portion as edge strip as shown in Fig. 7.7. Then it recommends,

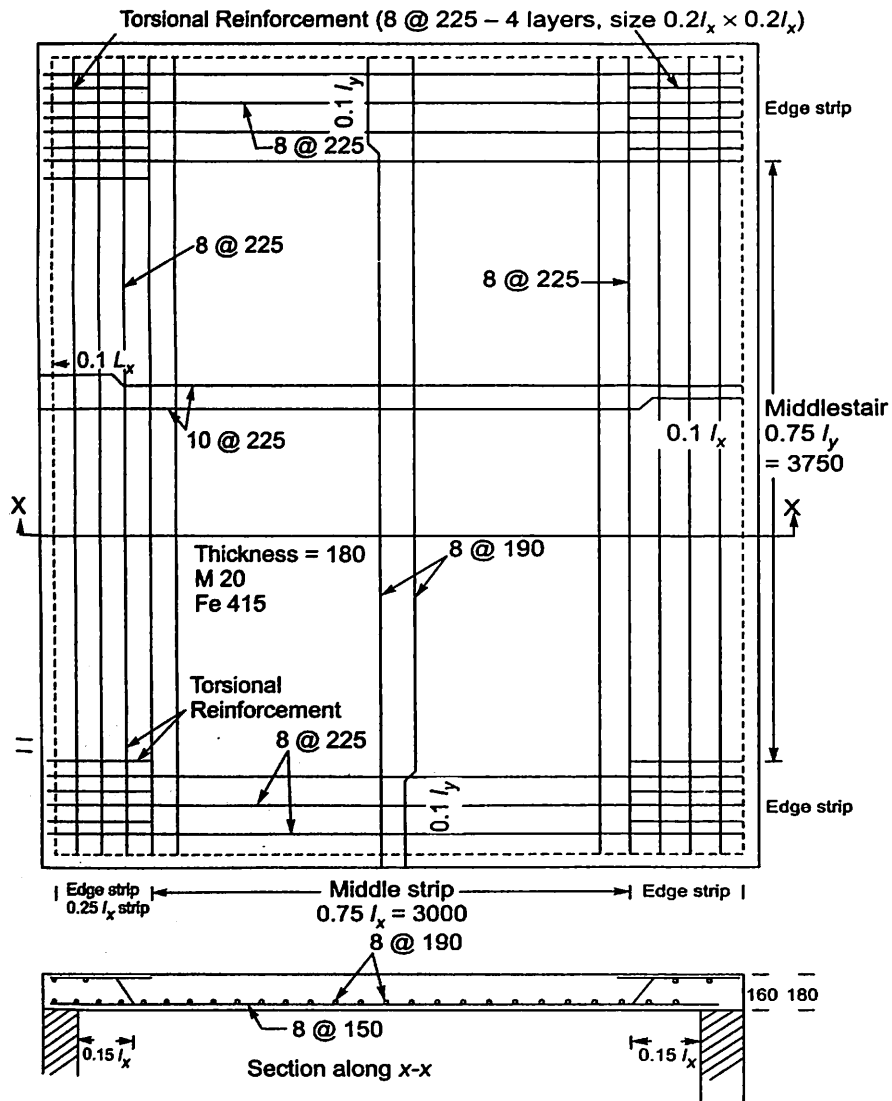

Fig. 7.7.

- (i) The maximum moment applies to only to middle strip.
- (ii) Tension reinforcements provided at mid strip shall extend in the lower part of the slab to within $0.25 l$ of a continuous edge or $0.15 l$ of discontinuous edge.
- (iii) Over the continuous edges of a middle strip, the tension reinforcement shall extend in the upper part of the slab a distance of $0.15 l$ from the support and at least 50 per cent shall extend a distance of $0.3 l$.
- (iv) Due to imperfection of boundary conditions, negative moment may occur at discontinuous edges. To take care of such moments, tension reinforcement equal to 50 per cent of that provided at mid span extending to $0.1 l$ in to the span will be sufficient.
- (v) Reinforcement in edge strip, parallel to that edge, shall comply with the minimum requirement.
- (vi) Torsional reinforcement:

Torsional reinforcement is to be provided at corners where two adjacent edges are discontinuous/simply supported. It consists of two layers of reinforcement mesh at top and other at bottom of slab with required cover. The area of reinforcement in each of these four layers shall be $\frac{3}{4}$ th of the area required for the maximum mid span in the slab and shall be of length $\frac{1}{5}$ th of the shorter span.

Design Procedure

- (i) From serviceability criteria, depth required is much less compared to one way slab, if short span is less than 3.5 m and live load less than 3 kN/m^2 . For such slab allowable

$\frac{L_x}{d}$ ratio is as follows:

	Fe 250	Fe 415 or Fe 500
For simply supported	35	28
For fixed or continuous	40	32

For two way slab with shorter span greater than 3.5 m or live load greater than 3 kN/m^2 ,

the allowable $\frac{L}{d}$ ratio same as for one way slab.

- (ii) Find effective l_x and l_y .
- (iii) Calculate design moments using coefficients given in table 26 or 27 in (IS 456) and shear

$$V_{ux} \text{ at support. Design shear } V_{ux} = W_u \frac{r^4}{1+r^4} \frac{l_x}{2}. \text{ Where } r = \frac{l_y}{l_x}$$

- (iv) Design reinforcements in both directions.
- (v) Check for deflection control.
- (vi) Provide reinforcements as per the IS 456 guidance which will take care of crack width control.
- (vii) Design torsion reinforcements at corners where two discontinuous edges meet.

Example 7.4. Design a reinforced concrete slab for a room of clear dimensions $4 \text{ m} \times 5 \text{ m}$. The slab is supported all around on walls of width 300 mm. The slab has to carry a live load of 4 kN/m^2 and floor finish 1 kN/m^2 . Use M20 concrete and Fe 415 steel. Assume corners are held down. Sketch the details of reinforcements.

Solution:**Thickness**

Since

take

$$l_x > 3.5,$$

$$\frac{\ell}{d} = 25 \text{ i.e. } d = \frac{\ell}{25} \text{ say } 160 \text{ mm}$$

$$D = 180 \text{ mm}$$

Effective Span:

Now

$$l_x = 4 + 0.16 = 4.16 \text{ m}$$

$$l_y = 5 + 0.16 = 5.16 \text{ m}$$

∴

$$\frac{\ell_y}{\ell_x} = \frac{5.16}{4.16} = 1.25 < 2$$

Hence two way slab is to be designed.

Design Moment and Shear:

Loads:

$$\text{Self wt} = 0.18 \times 1 \times 1 \times 25 = 4.5 \text{ kN/m}^2$$

$$\text{Finishing} \quad 1 \text{ kN/m}^2$$

$$\text{Live load} \quad 4 \text{ kN/m}^2$$

$$\text{Total} \quad 9.5 \text{ kN/m}^2$$

$$\text{Factored load} \quad w_u = 1.5 \times 9.5 = 14.25 \text{ kN/m}^2$$

The slab is simply supported on all the four sides, (since it rests on walls). The corners are held down by providing torsional reinforcement. Hence moment coefficients are obtained from table 7.1 (table 26, IS 456), case 9

$$\alpha_x = 0.072 + 0.007 \times \frac{4}{10} = 0.0748$$

$$\alpha_y = 0.056$$

$$M_u = 0.0748 \times 14.25 \times 4.16^2 = 18.45 \text{ kN-m.}$$

$$M_y = 0.056 \times 14.25 \times 4.16^2 = 13.81 \text{ kN-m}$$

$$V_u = 14.25 \times \frac{1.24^4}{1 + 1.24^4} \times \frac{4.16}{2} = 17.96 \text{ kN.}$$

Design of Main Reinforcement**(i) Reinforcements in x - directions:**

$$d = 160 \text{ mm.}$$

$$x_{u \text{ lim}} = 0.48 \times 160 = 76.8$$

$$M_{u \text{ lim}} = 0.36 \times f_{ck} \times b \times x_{u \text{ lim}} (d - 0.42 x_{u \text{ lim}})$$

$$= 70.63 \times 10^6 \text{ N-mm}$$

$$= 70.63 \text{ kN-m.}$$

$M_u < M_{u \text{ lim}}$. Hence under reinforced section.

∴

$$18.45 \times 10^6 = 0.87 \times 415 \times A_{st} \times 160 \left[1 - \frac{A_{st}}{1000 \times 160} \times \frac{415}{20} \right]$$

$$319.38 = A_{st} \left[1 - \frac{A_{st}}{7710.84} \right]$$

$$\therefore A_{st}^2 - 7710.84 A_{st} + 319.38 \times 7710.84 = 0.$$

$$A_{st} = \frac{7710.84 - \sqrt{7710.84^2 - 4 \times 319.38 \times 7710.84}}{2}$$

$$= 333.83 \text{ mm}^2.$$

Using 10 mm bars,

$$\text{Spacing} = \frac{\pi/4 \times 10^2}{333.83} \times 1000 = 235.3 \text{ mm}$$

Hence provide 10 mm bars at 225 mm c/c.

(ii) **Reinforcements in y-directions:**

These reinforcements will be placed above the reinforcements in x-direction. Hence in these case.

$$d = 160 - 8 = 152 \text{ mm}$$

From the relation,

$$M_u = 0.87 f_y A_{st} d \left(1 - \frac{A_{st}}{bd} \frac{f_y}{f_{ck}} \right), \text{ we get}$$

$$13.81 \times 10^6 = 0.87 \times 415 A_{st} \times 152 \left(1 - \frac{A_{st}}{1000 \times 152} \times \frac{415}{20} \right)$$

$$251.64 = A_{st} \left[1 - \frac{A_{st}}{7325.30} \right]$$

$$A_{st}^2 - 7325.30 A_{st} + 251.64 \times 7325.30 = 0$$

$$A_{st}^2 = \frac{7325.30 - \sqrt{7325.30^2 - 4 \times 251.64 \times 7325.30}}{2}$$

$$= 260.9 \text{ mm}^2.$$

Using 8 mm bars, spacing.

$$S = \frac{\pi/4 \times 8^2}{260.9} \times 1000 = 192$$

Provide 8 dia bars at 190 mm c/c.

It satisfies the prescribed maximum spacing clauses (i.e., $3 \times d$ or 300 mm whichever is less)

Check for Shear:

$$\tau_c = \frac{V_u}{bd} = \frac{17.96 \times 1000}{1000 \times 160} = 0.112$$

$$p_t = \frac{\pi/4 \times 10^2 \times 100}{225 \times 160} = 0.218$$

150 Design of R.C.C. Structural Elements

Permissible basic $\tau_c = 0.33 \text{ N/mm}^2$

Enhancement factor for slab of 180 mm thickness is 1.24 (Clause 40.2.1.1)

$$\therefore \text{Permissible shear} = 0.33 \times 1.24 = 0.409 \text{ N/mm}^2$$

$$\tau_{c \text{ max}} = \frac{1}{2} \times 2.8 = 1.4 \text{ N/mm}^2$$

Thus $\tau_v < \tau_c$

and $< \tau_{c \text{ max}}$.

Hence shear reinforcements are not required.

Check for Deflections Criteria :

$$\frac{L}{d} \text{ provided} = \frac{4.16 \times 1000}{160} = 26.$$

$$\text{Basic } \frac{L}{d} = 20, P_t = 0.218,$$

$$f_s = 0.98 \times 415 \times \frac{A_{st \text{ reqd}}}{A_{st \text{ provided}}} = 240$$

\therefore

$$F_1 = 1.60$$

\therefore

$$\frac{L}{d} \text{ max} = 20 \times 1.6 = 32.$$

Thus $\frac{L}{d} \text{ provided} < \frac{L}{d} \text{ max}$.

\therefore Deflection control is satisfactory.

Torsional Reinforcement at Corners:

$$\text{Size of mesh} = \frac{l_x}{5} = \frac{4.16}{5} = 0.832 \text{ m.} = 832 \text{ mm.}$$

$$\text{Size of wall} = 300 \text{ mm.}$$

\therefore Provide mesh of size $300 + 832 = 1100 \text{ mm}$
with side cover of 30 mm.

Area of torsional reinforcement

$$= \frac{3}{4} \times 333.83 = 250.05 \text{ mm}^2.$$

Using 8 mm bars

$$S = \frac{\frac{\pi}{4} \times 8^2}{250.05} \times 1000 = 201 \text{ mm c/c.}$$

\therefore provide 8 mm mesh of 200 mm c/c.

Reinforcement in Edge Strip:

$$A_{st} = \frac{0.12 \times 1000 \times 180}{1000} \times 216 \text{ mm}^2$$

$$s = \frac{\frac{\pi}{4} \times 8^2}{216} \times 1000 = 232 \text{ Provide 8 mm @ 225 c/c.}$$

The reinforcement detail is shown in Fig. 7.7.

Example 7.5. Design a slab for a room of clear internal dimensions $3\text{ m} \times 5\text{ m}$ supported on walls of 300 mm thickness, with corners held down. Two adjacent edges of the slab are continuous and other two discontinuous. Live load on the slab is 3 kN/m^2 . Assume floor finish of 1 kN/m^2 . Use M20 concrete and Fe 415 steel. Sketch the details of reinforcements.

Solution.

Since $\frac{l_y}{l_x} < 2$, it will be two way slab.

Thickness of Slab

As $l_x < 3.5\text{ m}$ and load is 3 kN/m^2 only, from deflection criteria, depth of slab required is given by $\frac{l_x}{d} = 32$.

$$\begin{aligned} \text{Hence let } d &= \frac{3000}{32} \\ \text{say } d &= 100\text{ mm} \\ D &= 125\text{ mm} \end{aligned}$$

Effective span : As thickness of wall is more than depth of slab,

$$l_x = 3000 + 100 = 3100\text{ mm} = 3.1\text{ m}$$

$$l_y = 5000 + 100 = 5100\text{ mm} = 5.1\text{ m}$$

$$\therefore \frac{l_y}{l_x} = \frac{5.1}{3.1} = 1.65$$

Bending Moment & shear Force:

$$\text{Self weight of slab} = 0.125 \times 1 \times 1 \times 25 = 3.125\text{ kN/m}^2$$

$$\text{Floor finish} = 1\text{ kN/m}^2$$

$$\text{L L} = 3\text{ kN/m}^2$$

$$\text{Total} = 7.125\text{ kN/m}^2$$

$$\therefore w_u = 1.5 \times 7.125 = 10.69\text{ kN}$$

\therefore Referring to case 4 in table 26 (in IS 456), in short span direction,

$$\text{Coefficient for -ve moment} = 0.075 + \frac{15}{25} (0.084 - 0.075) = 0.0804$$

$$\text{Coefficient for +ve moment} = 0.056 + \frac{15}{25} (0.063 - 0.056) = 0.0602$$

For long span,

$$\text{Coefficient for -ve moment} = 0.047$$

$$\text{And Coefficient for +ve moment} = 0.035$$

\therefore Design -ve moment for short span

$$= 0.0804 \times 10.69 \times 3.1^2 = 8.26\text{ kN-m}$$

$$\text{Design -ve moment for long span} = 0.047 \times 10.69 \times 3.1^2 = 4.828\text{ kN-m}$$

$$\text{Design +ve moment for short span} = 0.0602 \times 10.69 \times 3.1^2 = 6.18\text{ kN-m}$$

Design +ve moment for long span = $0.035 \times 10.69 \times .1^2 = 3.560 \text{ kN-m}$

$$x_{u \text{ lim}} = 0.48 \times 100 = 48$$

$$\begin{aligned} M_{u \text{ lim}} &= 0.36 f_{ck} b x_{u \text{ lim}} (d - 0.42 x_{u \text{ lim}}) \\ &= 0.36 \times 20 \times 1000 \times 48 (100 - 0.42 \times 48) \\ &= 27.592 \times 10^6 \text{ N-mm.} \\ &= 27.592 \text{ kN-m.} > M_u. \end{aligned}$$

\therefore Singly reinforced section can be designed.

Design for -ve Reinforcement:

Using the expression,

$$M_u = 0.87 f_y A_{st} d \left[1 - \frac{A_{st}}{bd} \frac{f_y}{f_{ck}} \right]$$

for short span direction, we get

$$8.26 \times 10^6 = 0.87 \times 415 \times A_{st} \times 100 \left[1 - \frac{A_{st}}{1000 \times 100} \times \frac{415}{20} \right]$$

$$228.777 = A_{st} \left[1 - \frac{A_{st}}{4819.277} \right]$$

$$\text{i.e., } A_{st}^2 - 4819.277 A_{st} + 228.777 \times 4819.277 = 0.$$

$$\begin{aligned} A_{st} &= \frac{4819.277 - \sqrt{4819.277^2 - 4 \times 1 \times 228.777 \times 4819.277}}{2} \\ &= 240.8 \text{ mm}^2. \end{aligned}$$

Using 8 mm dia @ spacing reqd is given by

$$s = \frac{\pi/4 \times 8^2}{240.8} \times 1000 = 208 \text{ mm.}$$

Provide 8 @ 200 c/c.

Reinforcement in long direction:

$$M_u = 4.828 \text{ kN-m}$$

$$d = 100 - 8 = 92$$

$$\therefore 4.828 \times 10^6 = 0.87 \times 415 A_{st} 92 \left(1 - \frac{A_{st}}{1000 \times 92} \times \frac{415}{20} \right)$$

$$145.349 = A_{st} \left[1 - \frac{A_{st}}{4433.73} \right]$$

$$\text{i.e., } A_{st}^2 - 4433.735 A_{st} + 145.349 \times 4433.735 = 0$$

$$\begin{aligned} A_{st} &= \frac{4433.735 - \sqrt{4433.735^2 - 4 \times 145.349 \times 4433.735}}{2} \\ &= 150.45 \text{ mm}^2 \end{aligned}$$

$$A_{st} \text{ Minimum} = \frac{0.12}{100} \times 1000 \times 125 = 150.$$

∴ Provide $A_{st} = 150.45 \text{ mm}^2$.

Using 8 mm dia Fe 415 steel, spacing reqd.

$$= \frac{\pi/4 \times 8^2}{150.45} \times 1000 = 334 \text{ mm.}$$

∴ Provide 8 mm bars at 300 mm c/c, which is maximum spacing permitted.

Provide the same in edge strips also.

Extend 50% of the tension steel to the supports and 50% steel to within $0.1l_x$ or $0.1l_y$ of the support as appropriate.

Torsional reinforcement at corner of two discontinuous edges:

$$A_{st} = \frac{3}{4} \times 240.8 = 180.6 \text{ mm}^2$$

Using 8 mm bars,

$$s = \frac{\pi/4 \times 8^2}{180.6} \times 1000 = 278 \text{ mm}$$

Provide 8 mm bars at 275 mm c/c

Design for +ve moment:

In x – direction $M_u = 6.18 \text{ ka-m.}$

$$\therefore 6.18 \times 10^6 = 0.87 \times 415 A_{st} \times 100 \left(1 - \frac{A_{st}}{1000 \times 100} \times \frac{415}{20} \right)$$

$$171.167 = A_{st} \left[1 - \frac{A_{st}}{4819.277} \right]$$

$$A_{st}^2 - 4819.277 A_{st} + 171.167 \times 4819.277 = 0.$$

$$A_{st} = \frac{4819.277 - \sqrt{4819.277^2 - 4 \times 1713167 \times 4819.277}}{2}$$

$$= 177.7 \text{ mm}^2$$

Provide 8 dia bars. Spacing reqd

$$s = \frac{\pi/4 \times 8^2}{177.7} \times 1000 = 282 \text{ mm}$$

Provide 8 dia bars at 275 mm c/c.

In y – direction, $M_u = 3.56$. Too small. Provide 8 @ 300 mm c/c.

Check for Shear:

$$V_u = 0.5 w_u l_x \frac{r^4}{1+r^4}$$

$$= 0.5 \times 10.69 \times 3.1 \frac{1.65^4}{1+1.65^4} = 14.6 \text{ kN.}$$

$$\tau_v = \frac{14.6 \times 1000}{1000 \times 100} = 0.146 \text{ N/mm}^2$$

$$p_t = \frac{\pi/4 \times 8^2}{200 \times 100} \times 100 = 0.251$$

$\therefore \tau_c$ from table 19 in IS 456

$$= 0.36.$$

Enhancement factor for slab of thickness less than 150 mm = 1.3.

$$\tau_c = 1.3 \times 0.36 = 0.468 \text{ N/m}^2$$

$$\tau_{c \text{ max}} = 0.5 \times 2.8 = 1.4 \text{ N/mm}^2$$

Then $\tau_v < \tau_c$
and also $< \tau_{c \text{ max}}$

Hence safe in shear.

Check for deflection Control:

$$\frac{L}{d} \text{ Provided} = \frac{3100}{100} = 31.$$

From Fig. 4 in IS 456,

$$\frac{L}{d} \text{ max} = 1.56 \times 20 = 31.2$$

Thus $\frac{L}{d} \text{ provided} < \frac{L}{d} \text{ max}$

\therefore Deflection control is satisfactory.

Reinforcements detail is shown in Fig. 7.8

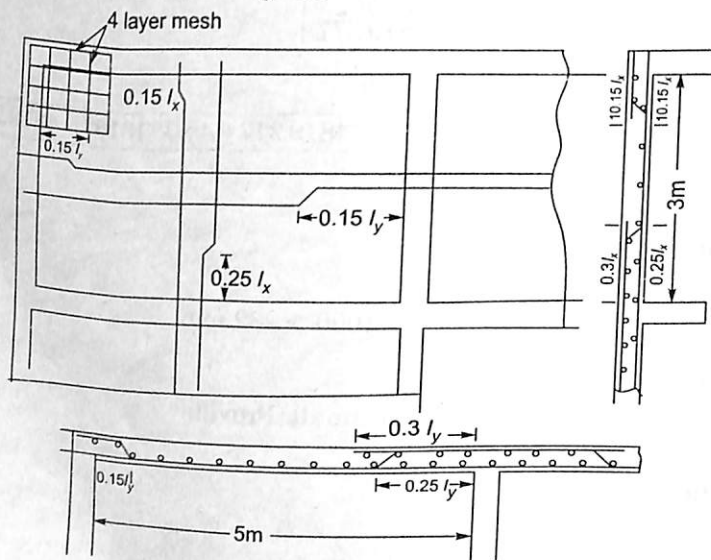

Fig. 7.8.

QUESTIONS

1. Design a corridor slab for a college building given:

Width of corridor = 2.5 m

Live load = 5 kN/m²

Finishing load = 1 kN/m²

Use M20 concrete mix and Fe 415 steel.

2. Design a one way continuous slab of spans 3.6 m, if imposed load is 3 kN/m² and finishing load is 1 kN/m². Assume width of beams as 250 mm. Use M20 concrete and Fe 415 steel.
3. Design a cantilever slab of span 2 m to carry a imposed load of 2 kN/m² over its entire span. Take finishing load as 0.5 kN/m². Use M20 concrete and Fe 415 steel. Sketch the details of reinforcement, if the slab is supported by a beam of size 300 mm × 500 mm.
4. Design a reinforced concrete slab for a room of size 5.5 × 4 m clear in size if the superimposed load is 5 kN/m². Use M20 concrete and Fe 415 steel. The edges are simply supported and corners are held down.
5. Design a reinforced concrete slab of size 6 m × 4 m whose one short edge is discontinuous and corners are restrained at supports. The slab has to carry a live load of 3 kN/m² and a floor finish of 1 kN/m². Use M20 concrete and Fe 415 steel. Sketch the details of reinforcements.

Design of Columns

8.1 INTRODUCTION

Column is a compression member, the effective length of which exceeds three times the least lateral dimension. A compression member with effective length less than three times least lateral dimension is called pedestal. The design procedure for columns hold good for the design of struts also, since strut is also a compression member. Note that difference between columns and struts is that column transfers the load to footing while strut transfers the load to some other member as in case of compression members of trusses. A column is considered as short, if its effective length to least lateral dimension is less than 12. If the above ratio exceeds 12, the column is treated as long or slender.

In this chapter the terms length and effective length of column is explained. Then various loads acting on the columns is presented. The slenderness limits and minimum eccentricity terms are explained. Then design of short columns subjected to axial load and columns subjected to combined axial and moments is illustrated. The design of slender (long) columns is also explained.

8.2 LENGTH OF COLUMNS

The unsupported length of column may be taken as clear distance between end restraints. In the normal situation there should not be any problem in finding this value, but in the following situations, the unsupported length ' l ' may be taken as indicated below:

- (i) **Flat Slab construction:** It is clear distance between the floor and the lower extremity of the capital, the drop panel or slab whichever is less (Fig. 8.1).

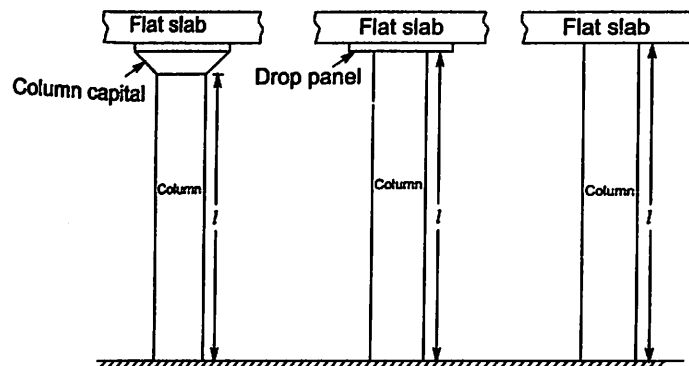

Fig. 8.1. Length in Flat Slab Construction.

(ii) **Beam and Slab Construction:** In this case l is the clear distance between the floor and the underside of the shallow beam framing into the column in each direction at the next higher level as shown in Fig. 8.2.

(iii) **Columns Restrained Laterally by Struts:** In these cases unsupported length l is the clear distance between consecutive struts in each vertical plane, provided that two such struts meet the column approximately at the same level and the angle between the vertical planes through the strut shall not vary more than 30° from a right angle (Ref. Fig. 8.3). However it may be noted that such struts shall be of adequate dimensions and should have sufficient anchorage to restrain the member against lateral deflections.

(iv) **Columns Restrained Laterally by Struts or Beams using Brackets at the Junction:** In these cases the unsupported length l shall be the clear distance between the floor and the lower edge of the bracket (Fig. 8.4), provided that the bracket width equals that of the beam or strut and is at least half that of the column.

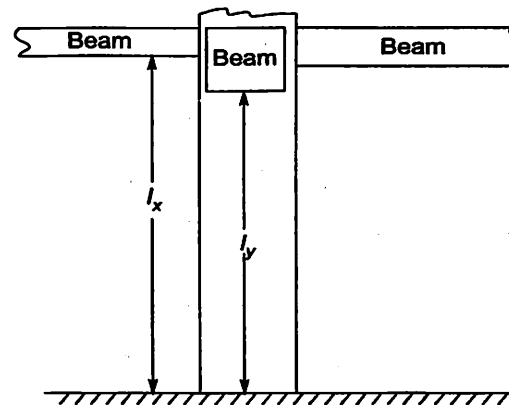

Fig. 8.2. Length in Beam and Slab Construction

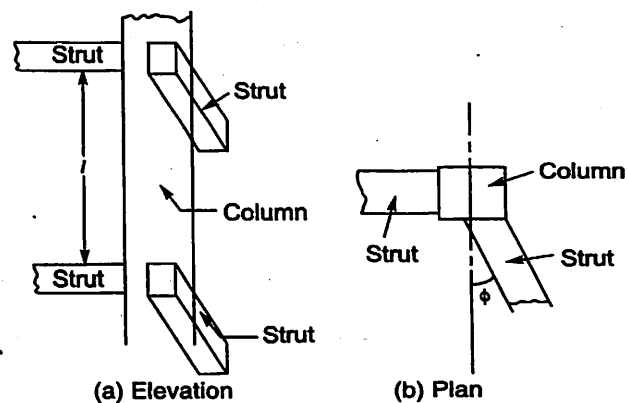

Fig. 8.3. Length of Columns Restrained Laterally by Struts

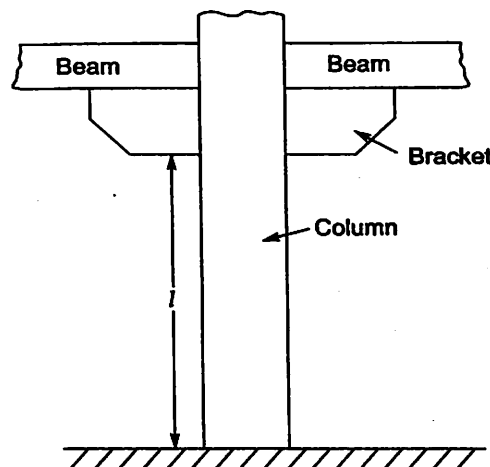

Fig. 8.4. Length of columns restrained laterally using brackets.

8.3. EFFECTIVE LENGTH

In the subject strength of materials it has been shown that Euler's buckling load for columns with different end conditions works out to be of the form $P_{cr} = \alpha \frac{\pi^2 EI}{l^2}$. All these cases may be represented by a single expression like

$$P_{cr} = \frac{\pi^2 EI}{l^2},$$

if we define L as effective length.

The buckling load $\alpha \frac{\pi^2 EI}{l^2}$ can be found for idealized end conditions. In practice end conditions are never ideal. For example in case of framed structures, it is difficult to idealise ends as fixed, free or hinged. IS 456 gives a method of determining the effective length for such cases which is in terms of stiffnesses of members meeting at the joint. It also depends upon whether the frame joint sways or do not sway. For this the reader may refer Annex E in IS 456.

In normal usage idealized end conditions may be assumed and effective length determined as shown in table 8.1 (Table 28 in IS 456). These values slightly differ from the theoretical values.

Table 8.1 Effective Length of Compression Members
[Table 28 of IS 456-2000]

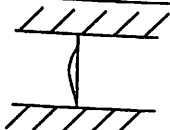
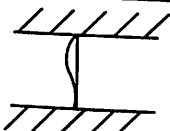
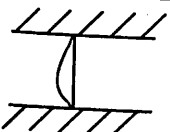
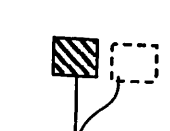
Degree of End Restraint of Compression Members	Symbol	Theoretical Value of Effective Length	Recommended Value of Effective Length
(1)	(2)	(3)	(4)
Effectively held in position and restrained against rotation in both ends.		$0.50 l$	$0.65 l$
Effectively held in position at both ends, restrained against rotation at one end.		$0.70 l$	$0.80 l$
Effectively held in position at both ends, but not restrained against rotation.		$1.00 l$	$1.00 l$
Effectively held in position and restrained against rotation at one end, and at the other restrained against rotation but not held in position		$1.00 l$	$1.20 l$

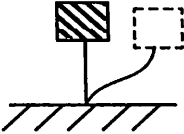
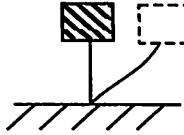
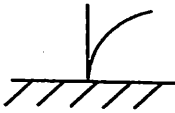
<i>Degree of End Restraint of Compression Members</i>	<i>Symbol</i>	<i>Theoretical Value of Effective Length</i>	<i>Recommended Value of Effective Length</i>
(1)	(2)	(3)	(4)
Effectively held in position and restrained against rotation in one end, and at the other partially restrained against rotation but not held in position		—	$1.50 l$
Effectively held in position at one end but not restrained against rotation, and at the other end restrained against rotation but not held in position		$2.00 l$	$2.00 l$
Effectively held in position and restrained against rotation at one end but not held in position nor restrained against rotation at the other end.		$2.00 l$	$2.00 l$

Note: l is the unsupported length of compression member.

8.4. LOADS ON COLUMNS

The columns get the load from beams. The end reaction of the beam is the load on the column supporting the beam at that end. Self weight is also to be considered. The load on the column may be central or may be eccentric. Apart from the vertical load we know from structural analysis that columns are subjected to moment also. Moment may be uniaxial if plane frame action is predominant or it may be biaxial, if the frame action is predominate in both directions.

8.5. SLENDERNESS LIMITS FOR COLUMNS

IS 456 clause 25.3 imposes the following slenderness limits for columns:

- (i) The unsupported length l shall not exceed 60 times the least lateral dimension of the column, ($l \nless 60b$).

(ii) If in any given plane, one end of the column is unrestrained

$$l \geq 100 \frac{b^2}{D}$$

where b = width at that section

and D = depth at that section.

8.6 MINIMUM ECCENTRICITY

No column can have perfectly axial load. There may be some moments acting due to imperfection of construction or due to actual conditions of loadings. Hence IS 456 clause 25.4 specifies minimum eccentricity to be considered in the column design as given below:

$$C_{\min} = \frac{l}{500} + \frac{\text{Lateral dimension}}{30},$$

subject to a minimum of 20 mm.

If biaxial bending is considered, it is sufficient to ensure that eccentricity exceeds the minimum about one axis at a time.

8.7 ASSUMPTIONS

In the limit state of collapse – compression, the following assumptions are made in addition to those made in the limit state of collapse – flexure:

- (i) The maximum compressive strain in concrete in axial compression is 0.002.
- (ii) The maximum compressive strain at the highly compressed extreme fibre in concrete subjected to axial compression and bending and when there is no tension shall be 0.0035 minus 0.75 times the strain at the least compressed extreme fibre.

Referring to Fig. 8.5,

$$\epsilon_{1\max} = 0.0035 - 0.75 \epsilon_2 \quad 8.1$$

8.8 DESIGN OF AXIALLY LOADED SHORT COLUMN

Making the assumptions listed above and taking care of minimum eccentricity clause, IS 456 specifies (Clause 39.3) that when minimum eccentricity does not exceed 0.05 times the lateral dimension, the member may be designed by using the following equation:

$$P_u = 0.4 f_{ck} A_c + 0.67 f_y A_{sc} \quad 8.2$$

where, P_u = Factored Axial load on the member

A_c = Area of concrete

and A_{sc} = Area of longitudinal reinforcement

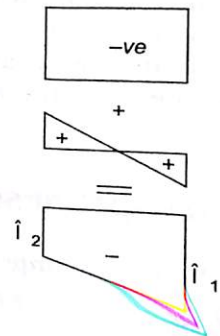
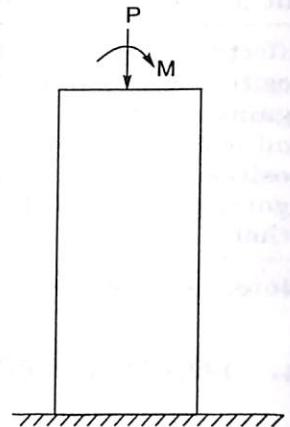

Fig. 8.5

If helical reinforcements are used instead of laterals, the strength value given by equation 8.2 may be multiplied by 1.05, provided in such case the ratio of the volume of helical reinforcement to the volume of the core shall not be less than

$$0.36 \left(\frac{A_g}{A_c} - 1 \right) \frac{f_{ck}}{f_y}$$

where A_g – Gross area of the section of column

and A_c – Area of the core of helically reinforced column measured to the outside diameter of the helix

The reinforcement selected by the designer should satisfy the clause 26.5.3 given in the IS code. Some of the important specification are given below:

(a) **Longitudinal Reinforcement:**

- (i) The cross sectional area of longitudinal reinforcement shall be not less than 0.8% nor more than 6% of gross sectional area. Where bars from the column below are to be lapped with those in the column under consideration, the steel shall usually not exceed 4 per cent. Thus it is preferable to maintain the reinforcement in the range 0.8 per cent to 4 per cent of gross area of column.
- (ii) In any column that has a larger cross sectional area than that required to support the load, the minimum percentage of steel shall be 0.8 per cent of required area rather than 0.8 per cent of area provided.
- (iii) Minimum number of bars to be provided are 4 for rectangular sections and 6 for circular sections spaced at equidistant.
- (iv) Minimum diameter of bars to be used is 12 mm.
- (v) Spacing of longitudinal bars measured along the periphery of the column shall not exceed 300 mm.

(b) **Transverse Reinforcement:**

These reinforcements are required to provide lateral support. If these reinforcements are not provided reinforcement may buckle and the failure of columns take. The transverse reinforcement provided should satisfy the following requirements:

- (i) The internal angle ϕ of the transverse reinforcement should not exceed 135° (Fig. 8.6.)

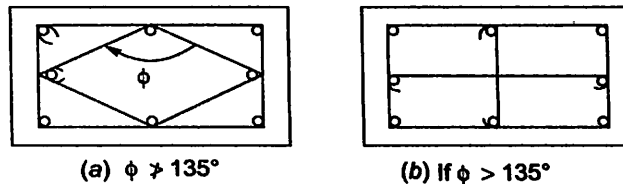

Fig. 8.6.

- (ii) If spacing of longitudinal bars is less than 75mm. alternate bars may be unsupported as shown in Fig. 8.6(c).

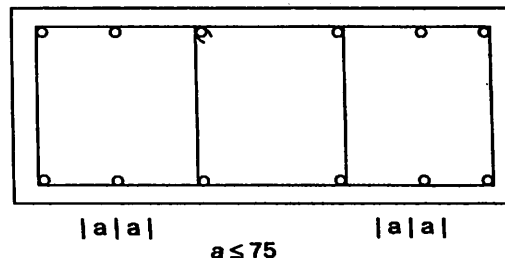

Fig. 8.6 (c)

(iii) Diameter of ties should not be less than

(a) $\frac{1}{4}$ th of largest diameter of longitudinal bars

(b) 5 mm.

(iv) The pitch of ties shall not be more than

(a) Least lateral dimension of the column.

(b) $16 \times$ the diameter of smallest longitudinal bar.

(c) 300 mm.

(v) The pitch of the helical reinforcement should satisfy the following requirement, if its strength is enhanced by 1.05.

(a) not more than 75 mm.

(b) not more than $\frac{1}{6}$ th core diameter of helix bars

(c) not less than 25 mm.

(d) not less than 3 times the diameter of helix bars.

Example 8.1. Design a column, 4 m long restrained in position and direction at both ends to carry an axial load of 1600 kN. Use M20 concrete and Fe 415 steel.

Solution :

Both ends are fixed.

$$l = 4.0 \text{ m.}$$

\therefore

$$l_{eff} = 0.65l = 0.65 \times 4 = 2.6 \text{ m.}$$

$$P_u = 1.5 \times 1600 = 2400 \text{ kN.}$$

Assuming 1% steel, we get, $A_c = 99\% A_g$ and $A_{sc} = 1\% A_g$.

$$2400 \times 1000 = 0.4 \times 20 \frac{99}{100} A_g + 0.67 \times 415 \times \frac{1}{100} A_g.$$

\therefore

$$A_g = 224288 \text{ mm}^2.$$

Using a square column, size.

$$= \sqrt{224288} = 474 \text{ mm.}$$

Provide 500 mm \times 500 mm. column.

Check for slenderness of column

$$\frac{l_{eff}}{b} = \frac{2600}{500} = 5.2 < 12$$

\therefore It is a short column.

Minimum eccentricity

$$e_{min} = \frac{l}{500} + \frac{D}{30} = \frac{4000}{500} + \frac{500}{30} = 24.67$$

\therefore

$$\frac{e_{min}}{D} = \frac{24.67}{500} = 0.049 < 0.05$$

Hence design as axially loaded short column is satisfactory.

Longitudinal Reinforcement:

$$A_{sc} = \frac{1}{100} \times A_g \text{ regd}$$

$$= \frac{1}{100} \times 224288 = 2243 \text{ mm}^2.$$

Provide 8 bars of 20 mm. diameter. (Always provide even number of bars, preferably in multiples of 4)

Lateral Ties:

Diameter of lateral ties should not be less than

$$(a) \frac{\phi}{4} = \frac{20}{4} = 5\text{mm}$$

$$(b) 5 \text{ mm.}$$

Hence use 6 mm bars.

Spacing : It shall be minimum of

$$(a) \text{ least lateral dimension} = 500 \text{ mm.} \quad (b) 16 \times \phi = 16 \times 20 = 320 \text{ mm.}$$

$$(c) 300 \text{ mm.}$$

∴ Provide 6 mm lateral ties at 300 mm.c/c as shown in Fig 8.8

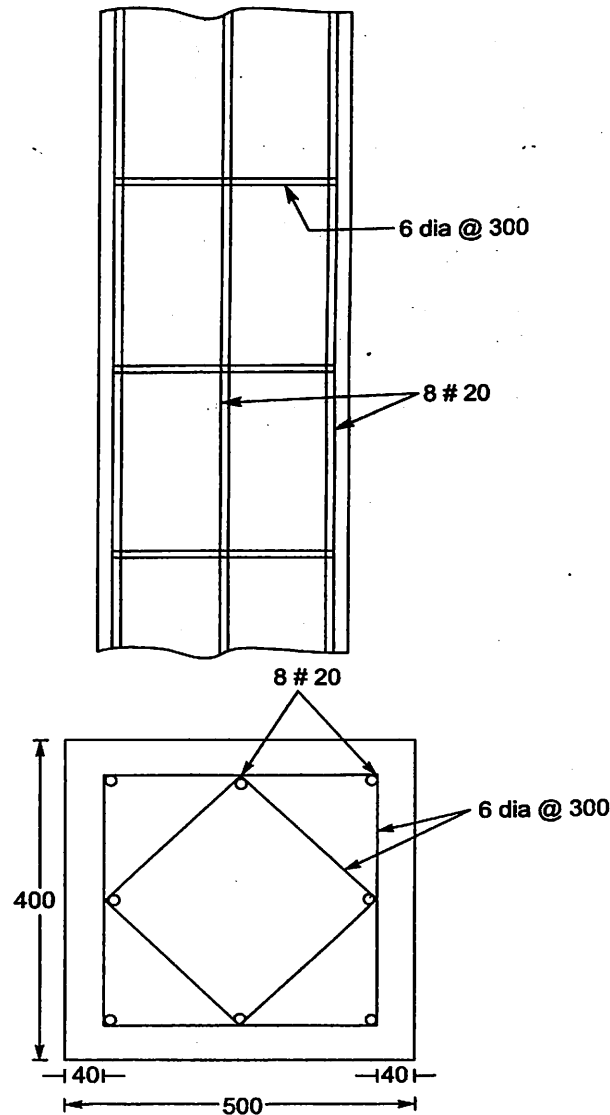

Fig. 8.7. Details of Reinforcement

Example 8.2. Design the reinforcement for a short axially loaded square column of size $400 \text{ mm} \times 400 \text{ mm}$ to support a load of 1000 kN . Use M20 concrete and Fe 415 steel.

Solution :

$$\begin{aligned} \text{Factored load, } P_u &= 1.5 \times 1000 \\ &= 1500 \text{ kN.} \\ &= 1500000 \text{ N} \end{aligned}$$

$$\text{size of the column} = 400 \text{ mm} \times 400 \text{ mm.}$$

$$\therefore A_g = 400 \times 400 = 160000 \text{ mm}^2.$$

Using 'p' percentage reinforcement, from the expression

$$P_u = 0.46 f_{ck} A_c + 0.67 f_y A_{sc}, \text{ we get}$$

$$1500000 = 0.40 \times 20 \times A_g \left(1 - \frac{p}{100}\right) + 0.67 \times 415 \times \frac{p}{100} A_g.$$

$$\text{i.e. } 1500000 = 0.40 \times 20 \times 160000 \left(1 - \frac{p}{100}\right) + 0.67 \times 415 \times \frac{p}{100} \times 160000 p$$

$$\therefore 1500000 = 1280000 - 12800 p + 444880 p.$$

$$\text{or } p = 0.509$$

This is less than minimum reinforcement of 0.8. Hence provide 0.8 per cent reinforcement.

To find required A_g .

$$1500 \times 1000 = A_g \left(1 - \frac{0.8}{100}\right) \times 0.4 \times 20 + 0.67 \times 415 \times \frac{0.8}{100} A_g.$$

$$A_g = 147632 \text{ mm}^2.$$

$$\therefore A_{sc} = \frac{0.8}{100} \times 147632 = 1181 \text{ mm}^2.$$

Provide 4 bars of 20 mm ϕ .

$$A_{sc} \text{ provide} = 1256 \text{ mm}^2.$$

Lateral Ties:

Diameter not less than

$$(a) \frac{\phi}{4} = \frac{20}{4} = 5 \text{ mm.}$$

$$(b) 5 \text{ mm.}$$

\therefore Use 6 mm ties.

Pitch: Not more than

$$(a) \text{ least lateral dimensions} = 400 \text{ mm.} \quad (b) 16 \times \phi = 16 \times 20 = 320 \text{ mm}$$

$$(c) 300 \text{ mm.}$$

\therefore provide 6 mm ties at 300 mm c/c.

The details are shown in Fig. 8.8

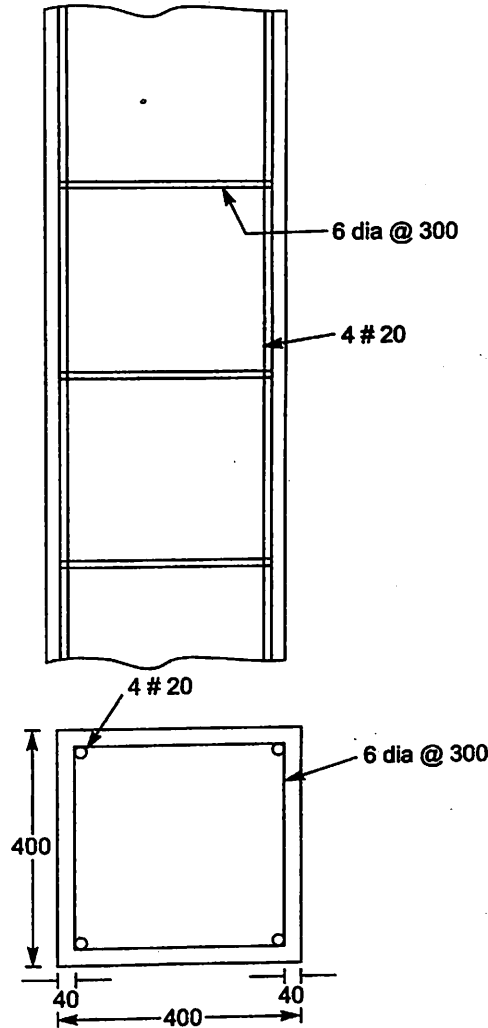

Fig. 8.8. Details of Reinforcement

Example 8.3. Design a circular column of diameter 400 mm with helical reinforcement subjected to a working load of 1200 kN. Use M25 concrete and Fe 415 steel. The column has unsupported length of 3 m and is effectively held in position at both ends, but not restrained against rotation.

Note: Sometimes dimensions are fixed from architectural consideration. Designer has to see that column can be designed with steel between 0.8 to 4 per cent.

Solutions :

Unsupported Length $l = 3 \text{ m.}$

Ends are effectively held at both ends and rotation not restrained (hinged ends)

$$\therefore L = l = 3 \text{ m.}$$

$$\therefore \frac{L}{d} = \frac{3000}{400} = 7.5 < 12$$

\therefore It may be designed as short column.

Minimum Eccentricity:

$$e_{\min} = \frac{L}{500} + \frac{D}{30} = \frac{3000}{500} + \frac{400}{30} = 19.33 < 20 \text{ mm.}$$

$$\therefore e_{\min} = 20 \text{ mm}$$

$$\text{also } \frac{e_{\min}}{D} = \frac{20}{400} = 0.05$$

Hence it may be treated as axially loaded column.

Main Reinforcement:

Since it can be treated as axially loaded column its load carrying capacity is given by

$$P_u = 1.05[0.4 f_{ck} A_c + 0.67 f_y A_{sc}]$$

$$P = 1200$$

$$P_u = 1.5 \times 1200 = 1800 \text{ kN} = 1800 \times 1000 \text{ N.}$$

Let p be the % reinforcement used.

$$A_c = A_g \left(1 - \frac{p}{100}\right)$$

$$A_{sc} = \frac{p}{100} A_g$$

$$\therefore \frac{1800 \times 1000}{1.05} = 0.4 \times 25 A_g \left(1 - \frac{p}{100}\right) + 0.67 \times 415 \frac{p}{100} A_g$$

$$= A_g \left[10 - \frac{p}{10} + 2.7805p\right]$$

$$= \frac{\pi}{4} \times 400^2 [10 + 2.6805p]$$

$$p = 1.3586$$

Thus p is between 0.8 & 4.0%. Hence satisfactory.

$$\therefore A_{sc} = \frac{p}{100} \times A_g = 1.3586 \times \frac{\pi}{4} \times 400^2 = 1707.3 \text{ mm}^2.$$

Provide 6 bars of 20 mm diameter.

$$A_{sc} \text{ provided} = 6 \times \frac{\pi}{4} \times 20^2 = 1885 \text{ mm}^2.$$

Helical Reinforcement

Let us try 8 mm spirals at pitch 'S' with clear cover of 50 mm.

$$\text{Core diameter} = 400 - 2 \times 50 = 300 \text{ mm.}$$

$$\text{Area of core } A_c = \frac{\pi}{4} \times 300^2 - 1885 = 68800 \text{ mm}^2$$

$$\text{Volume of core per pitch height } S, = 68800 \times S$$

$$\text{Length of one spiral of 8 mm diameter} = \pi (300 - 8) = 292 \pi$$

Volume of one spiral

$$V_{us} = \frac{\pi}{4} 8^2 \times 292 \pi$$

$$= 46110 \text{ mm}^3.$$

∴ According to clause in IS 456,

$$\frac{V_{us}}{V_c} \leq 0.36 \left[\frac{A_g}{A_c} - 1 \right] \frac{f_{ck}}{f_y}$$

Now

$$A_g = \frac{\pi}{4} \times 400^2 = 1256637 \text{ mm}^2$$

∴ According to the above clause,

$$\frac{46110}{68800S} \leq 0.36 \left[\frac{1256637}{68800} - 1 \right] \frac{25}{415}$$

∴

$$S \geq 37.4 \text{ mm.}$$

Maximum pitch specified : 75 mm. or

$$\frac{\text{Core diameter}}{6} = \frac{300}{6} = 50 \text{ mm.}$$

Minimum pitch : 25 mm or $3 \times$ diameter of helical reinforcement

$$= 24 \text{ mm.}$$

i.e.

$$24 \text{ mm.}$$

Provide 8 mm spirals at 40 mm pitch

Reinforcement detail is shown in Fig. 8.9.

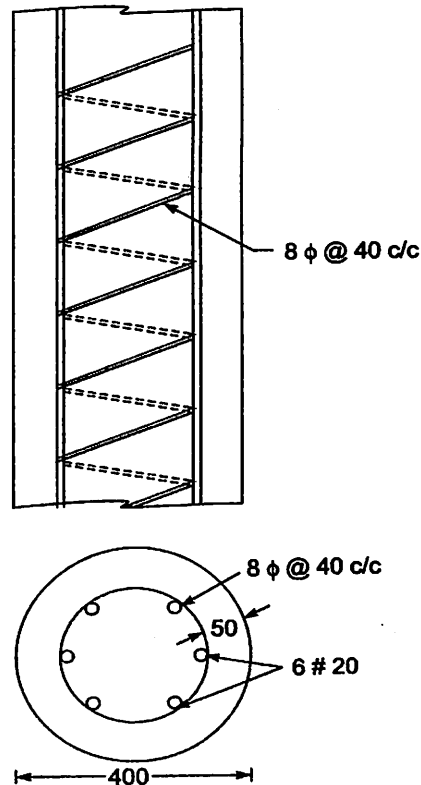

Fig 8.9.

8.9 DESIGN OF COLUMN SUBJECTED TO COMBINED AXIAL LOAD AND UNIAXIAL MOMENT (USING SP-16)

When there is no moment [$M_u = 0$], then it is a pure axial load case and in this case failure strain in compression is 0.002. For such case taking into account only minimum eccentricity IS code gives load carrying capacity as

$$P_u = 0.4 f_{ck} A_c + 0.67 f_y A_{sc}$$

If axial load $P_u = 0$ and bending moment M_u is the only load, it is pure moment case and hence the design will be like that of a beam.

But in design of many column, we know we come across the above two extreme cases. If axial load is more, naturally its moment carrying capacity will be less and vice versa also should hold good. IS 456 recommends design of such column with assumption (ii) listed earlier. Design of such columns involve lengthy calculations using equilibrium equations. Based on all such calculations interaction curves have been developed to assist designers and are presented in 'Design Aid for Reinforcement Concrete to IS: 456 - 1978' by Bureau of India Standard. This special publication is popularly known as SP - 16. A typical interaction diagram is as shown in Fig. 8.10. In this the following three points are clearly visible:

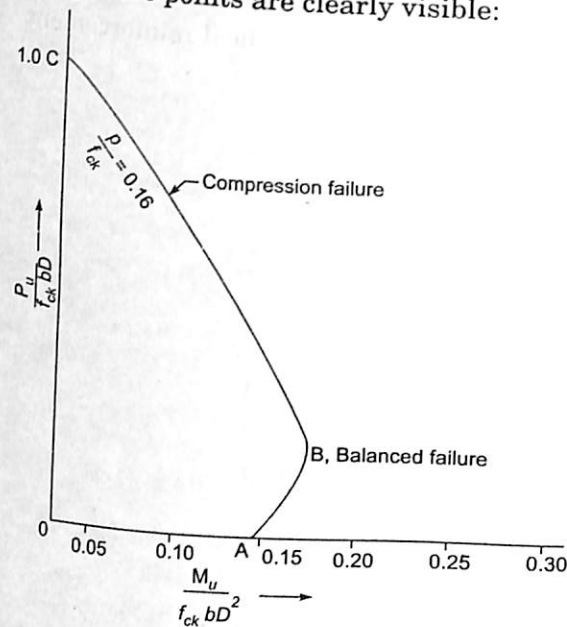

Fig. 8.10. Typical Interaction curve.

- A : Pure moment case
 - C : Pure compression case
 - B : Shows the point where failure strain in concrete and steel reach their limiting values simultaneously.
- In the region B to C compression failure takes place.

The design charts are given in the form of interaction diagram in which $\frac{P_u}{f_{ck}bD} Vs \frac{M_u}{f_{ck}bD^2}$ are plotted for different values of $\frac{p}{f_{ck}}$, where p is the percentage reinforcement. SP-16

gives charts for designing rectangular sections having reinforcements on two sides [Charts 27 to 38] as shown in Fig. 8.11 and for reinforcements on four sides [Charts 39 to 50] as shown in Fig. 8.12. The charts for the cases shown in Fig. 8.12 are prepared for a section with 20 bars equally distributed on all four sides, but they can be used without significant error for other numbers also. But to use these charts minimum of 8 bars should be selected, distributing equally on the four faces.

The charts for circular sections [chart 51 – 62] have been prepared for a section with 8 bars but they can be used for section with any number of bars but not less than 6. Charts have been given for three grades of steel and four values of $\frac{d'}{D}$ for each case mentioned above.

Example 8.4. A column of size 300 mm × 400 mm has effective length of 3.6 m and is subjected to $P_u = 1100$ kN and $M_u = 150$ kN-m about the major axis. Design the column using M25 concrete and Fe 415 steel, providing the steel

- On two sides
- On four sides.

Assume cover of 60 mm.

Solution :

$$L = 3.6 \text{ m} = 3600 \text{ mm} \quad D = 400 \text{ mm}$$

$$\frac{L}{D} = \frac{3600}{400} = 9 < 12.$$

Hence it can be designed as short column

Actual eccentricity

$$e = \frac{M_u}{P_u} = \frac{150 \times 10^6}{1100 \times 10^3} = 136 \text{ mm}$$

$$e_{\min} = \frac{L}{500} + \frac{D}{30} = \frac{3600}{500} + \frac{400}{30} = 20.53 \text{ mm.}$$

$$e > e_{\min}$$

Hence design it as short column subject to axial load and uniaxial moment.

In this problem,

$$\frac{P_u}{f_{ck}bD} = \frac{1100 \times 1000}{25 \times 300 \times 400} = 0.367$$

$$\frac{M_u}{f_{ck}bD^2} = \frac{150 \times 10^6}{25 \times 300 \times 400^2} = 0.125$$

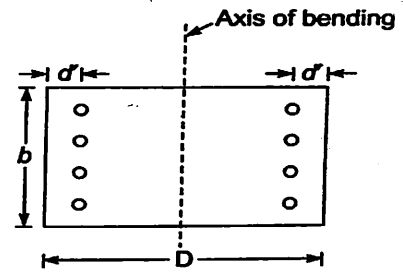

Fig. 8.11

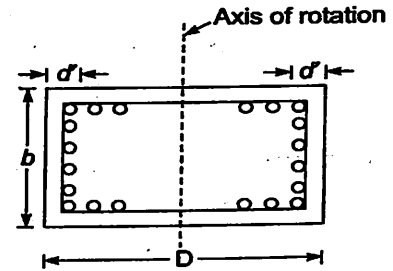

Fig. 8.12

$$\frac{d'}{D} = \frac{60}{400} = 0.15$$

(a) **Reinforcement on two faces only:**

Referring to chart No. 33 in SP-16.

$$\frac{p}{f_{ck}} = 0.093$$

∴

$$p = 0.093 \times 25 = 2.325$$

$$A_{sc} = \frac{2.325}{100} \times 300 \times 400 = 2790 \text{ mm}^2.$$

Provide 6 numbers of 25 mm dia bars, 3 on each face.

$$A_{sc} \text{ provided} = 2945 \text{ mm}^2.$$

Design of lateral Ties

Selecting 8 mm bars, maximum spacing $16 \times \phi = 16 \times 25 = 300$, least lateral dimension 300 mm. Hence provide 8 mm lateral ties at 300 mm c/c. as shown in Fig. 8.13.

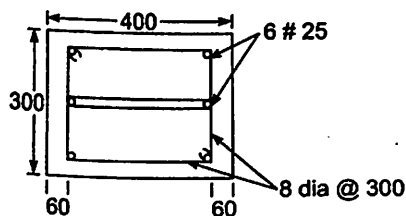

Fig. 8.13.

(b) **Reinforcement on all the 4 faces:**

From chart 45, for $\frac{P_u}{f_{ck}bd} = 0.367$

and

$$\frac{M_u}{f_{ck}bd^2} = 0.125, \frac{p}{f_{ck}} = 0.115$$

$$p = 0.115 \times 25 = 2.875$$

$$A_{sc} = \frac{2.875}{100} \times 300 \times 400 = 3450 \text{ mm}^2.$$

Provide 8 bars of 25 mm diameter.

$$A_{st} \text{ provided} = 3927 \text{ mm}^2.$$

In this case also laterals required will be 8 mm at a spacing of 300 mm c/c. Provide them as shown in Fig. 8.14.

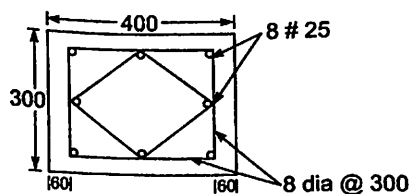

Fig. 8.14.

8.10 DESIGN OF COLUMNS SUBJECTED TO COMBINED AXIAL LOAD AND BIAxIAL MOMENTS

If three dimensional frame analysis is carried out, one can observe that many columns are subjected to axial load and biaxial bending. Biaxial bending is more predominate in the corner columns of buildings. The exact design of such columns is extremely laborious. IS 456 permits (clause 39.6) the design of such members using the following interaction formula:

$$\left[\frac{M_{ux}}{M_{ux1}} \right]^{\alpha_n} + \left[\frac{M_{uy}}{M_{uy1}} \right]^{\alpha_n} \leq 1.0$$

where,

M_{ux}, M_{uy} = Moments about x and y axes due to design load

M_{ux1}, M_{uy1} = maximum uniaxial moment capacity for an axial load P_u , bending about x and y axes respectively and α_n is related to P_u / P_{uz}

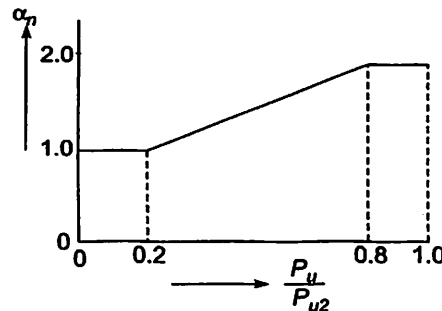

Fig. 8.15. Variation of α_n w.r.t. $\frac{P_u}{P_{u2}}$

where $P_{uz} = 0.45 f_{ck} A_c + 0.75 f_y A_{sc}$

For values of $\frac{P_u}{P_{uz}} = 0.2$ to 0.8 , the values of α_n vary linearly from 1.0 to 2.0 . For values less than 0.2 , α_n is 1.0 , for values greater than 0.8 , α_n is 2.0 .

\therefore For $\frac{P_u}{P_{uz}}$ between 0.2 to 0.8 .

$$\begin{aligned} \alpha_n &= 1 + \frac{\frac{P_u}{P_{uz}} - 0.2}{0.8 - 0.2} \times 1 \\ &= 1 + \frac{\frac{P_u}{P_{uz}} - 0.2}{0.6} \end{aligned}$$

However in using the above procedure designer may experience difficulty in calculating M_{ux1} and M_{uy1} . Since percentage steel 'p' is not known. For this trial value of p is to be assumed and proceed to check interaction formula.

Devadas menon had suggested that trial value of p may be selected based on axial load and a uniaxial moment of $M_u = 1.15 \sqrt{M_{ux}^2 + M_{uy}^2}$. This way number of trials may be reduced and

many times succeeding in first trial itself. Hence the following design procedure may be followed:

(i) Find $M_u = 1.15\sqrt{M_{ux}^2 + M_{uy}^2}$, Calculate $\frac{P_u}{f_{ck}bD}$ Find $\frac{d'}{D}$

Use appropriate chart in SP-16 for equal bars on all four faces to get $\frac{p}{f_{ck}}$ for axial load

$\frac{P_u}{f_{ck}bD}$ and M_u , the uniaxial moment. Calculate area of bars required and select equal number of bars (multiple of 4) on all the faces.

(ii) Find actual 'p' provided and hence $\frac{p}{f_{ck}}$. For $\frac{P_u}{f_{ck}bD}$ given and $\frac{p}{f_{ck}}$ provided, determine M_{ux1} using the appropriate chart in SP-16.

(iii) Similarly determine M_{uy1} .

(iv) Determine P_{uz} using the relation

$$P_{uz} = 0.45 f_{ck} A_c + 0.75 f_y A_{sc}$$

(v) Find α_n corresponding to $\frac{P_u}{P_{uz}}$.

(vi) Check whether interaction formula is satisfied.

(vii) If interaction formula is not satisfied increase 'p' and try again

(viii) Design transverse reinforcements.

The procedure is illustrated with the example below:

Example 8.5 A corner column 400×400 mm, is subjected to the factored loads $P_u = 1300$ kN, $M_{ux} = 190$ kN-m and $M_{uy} = 110$ kN-m. Design the reinforcement in the column, assuming M25 concrete and Fe 415 steel and effective cover of 60 mm. Assume it is a short column.

Solution:

Size of column 400×400 mm.

$$P_u = 1300 \text{ kN}, \quad M_{ux} = 190 \text{ kN-m}, \quad M_{uy} = 110 \text{ kN-m.}$$

$$f_{ck} = 25 \text{ N/mm}^2, \quad f_y = 415 \text{ N/mm}^2.$$

(i) **Selecting trial reinforcement**

$$\frac{P_u}{f_{ck}bD} = \frac{1300}{25 \times 400 \times 400} = 0.325$$

$$\text{Uniaxial } M_u \text{ trial} = 1.15 \sqrt{M_{ux}^2 + M_{uy}^2} = 1.15 \sqrt{190^2 + 110^2} = 252.5 \text{ kN-m}$$

$$\frac{M_u}{f_{ck}bD^2} = \frac{252.5 \times 10^6}{25 \times 400 \times 400^2} = 0.158$$

$$\frac{d'}{D} = \frac{60}{400} = 0.15$$

Referring to chart 45 in SP-16,

$$\frac{p}{f_{ck}} = 0.145$$

$$\therefore p = 0.145 \times 25 = 3.625$$

$$A_{sc} = \frac{3.625}{100} \times 400 \times 400 = 5800 \text{ mm}^2$$

Provide 12 bars of 25 mm diameter.

$$\therefore \text{Area provided} = 5890 \text{ (May ref to table 95 in SP-16)}$$

$$\therefore \text{Actual } p = \frac{5890}{400 \times 400} \times 100 = 3.68$$

$$\frac{p}{f_{ck}} = \frac{3.68}{25} = 0.147$$

(ii) To find M_{ux1} :

$$\frac{p}{f_{ck}} = 0.147, \frac{P_u}{f_{ck}bD} = 0.325 \quad \frac{d'}{D} = 0.15$$

\(\therefore\) From chart 45.

$$\frac{M_{ux1}}{f_{ck}bD^2} = 0.16$$

$$M_{ux1} = 0.16 \times 25 \times 400 \times 400^2 = 256 \times 10^6 \text{ N-mm} = 256 \text{ kN-m.}$$

(iii) To find M_{uy1}

Since $\frac{p}{f_{ck}}, \frac{P_u}{f_{ck}bD}$ and $\frac{M_u}{f_{ck}bD^2}$ are the same as above, here also.

$$M_{uy} = 256 \text{ kN-m.}$$

(iv) To find P_{uz}

$$P_{uz} = 0.45 f_{ck} A_c + 0.75 f_y A_{sc}$$

Now

$$A_c = 400 \times 400 - 5890 = 154110 \text{ mm}^2$$

$$A_{sc} = 5850 \text{ mm}^2.$$

\(\therefore\)

$$P_{uz} = 0.45 \times 25 \times 154110 + 0.75 \times 415 \times 5890 = 3567000 \text{ N} \\ = 3567 \text{ kN.}$$

(v) To find α_n

$$\frac{P_u}{P_{uz}} = \frac{1300}{3567} = 0.364$$

This is between 0.2 and 0.8

$$\therefore \alpha_n = 1 + \frac{0.364 - 0.2}{0.6} = 1.273$$

(vi) Checking Interaction Formula

$$\left[\frac{M_{ux}}{M_{ux1}} \right]^{\alpha_n} + \left[\frac{M_{uy}}{M_{uy1}} \right]^{\alpha_n} = \left[\frac{190}{256} \right]^{1.273} + \left[\frac{110}{256} \right]^{1.273} \\ = 0.684 + 0.341 = 1.025 > 1$$

- (vii) **Interaction formula is not satisfied. Needs revision**
 However since it slightly exceeds the prescribed value it may be accepted also.
- (viii) **Design of Ties**

$$\text{Diameter of Ties} = \frac{25}{4} = 6.25$$

Use 8 mm diameter ties

Maximum pitch:

(a) least lateral dimension = 400 mm

(b) $16 \times \phi = 16 \times 25 = 400$ mm.

(c) 300 mm.

Hence provide 8 mm ties at 300 mm c/c as shown in Fig. 8.16

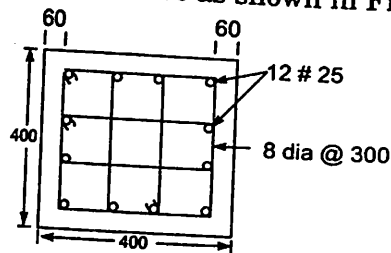

Fig. 8.16.

8.11 DESIGN OF SLENDER COLUMNS

Let D be the depth of column along the major axis- x and ' b ' be along minor axis- y . If l_{ex} is effective length with respect to x -axis and l_{ey} is effective length with respect to y -axis, then a column is treated as slender if $\frac{l_{ex}}{D}$ or $\frac{l_{ey}}{b}$ exceed 12. Lateral deflection of such columns, under axial load, is substantial and cause additional moments. IS 456, recommends the use of the following equations to find these additional moments M_{ax} and M_{ay} :

$$M_{ax} = P_u e_{ax} \text{ and } M_{ay} = P_u e_{ay}$$

$$\text{where } e_{ax} = \frac{D}{2000} \left(\frac{l_{ex}}{D} \right)^2$$

and

$$e_{ay} = \frac{D}{2000} \left(\frac{l_{ey}}{b} \right)^2$$

However, the code recommends the use of the following factors to reduce the values of M_{ax} and M_{ay} :

$$k = \frac{P_{uz} - P_u}{P_{uz} - P_b} \leq 1.$$

where $P_{uz} = 0.45 f_{ck} A_c + 0.75 f_y A_{sc}$ and P_b is the axial load corresponding to the condition of maximum compressive strain of 0.0035 in concrete and tension strain of 0.002 in outermost layer of tension steel. Table 8.2 (table 60 in SP-16) gives guide lines for finding P_b as shown below:

$$\frac{P_b}{f_{ck} b D} = k_1 + k_2 \frac{p}{f_{ck}} \text{ for rectangular sections and } \frac{P_b}{f_{ck} D^2} = k_1 + k_2 \frac{p}{f_{ck}} \text{ for circular sections.}$$

Table 8.2 (table 60 in IS 456)

Values of k_1

Section	d' / D			
	0.05	0.10	0.15	0.20
Rectangular	0.219	0.207	0.196	0.184
Circular	0.172	0.160	0.149	0.138

Values of K_2 :

Section	f_y in N/mm^2	d' / D			
		0.05	0.10	0.15	0.20
Rectangular, equal reinforcement on two opposite sides	250	-0.045	-0.045	-0.045	-0.045
	415	0.096	0.082	0.046	-0.022
	500	0.213	0.173	0.104	-0.001
Rectangular, equal reinforcement on four sides	250	0.215	0.146	0.061	-0.011
	415	0.424	0.328	0.203	0.028
	500	0.545	0.425	0.256	0.040
Circular	250	0.193	0.148	0.077	-0.020
	415	0.410	0.323	0.201	0.036
	500	0.543	0.443	0.291	0.056

According to the code the modification of M_{ux} and M_{uy} is optional. However it is suggested to take advantage of it, since the value of k could be substantially less than unity.

The notes given below the clause 39.7.1 suggest that the following moments be added to the additional moments:

$$M_{ux1} = 0.6 M_{x1} - 0.4 M_{x2}$$

$$M_{uy1} = 0.6 M_{y1} - 0.4 M_{y2}$$

Where M_{x1} and M_{y1} are larger end moments and M_{x2} and M_{y2} are smaller end moments. It is to be noted that the above corrections are for braced columns, without any transverse load and the column bending in double curvature.

It is also suggested that in no case the M_{ux1} and M_{uy1} shall be less than those calculated from the consideration of minimum eccentricity. Then the design moments are

$$M_{ux} = M_{ax} + M_{ux1}$$

$$M_{uy} = M_{ay} + M_{uy1}$$

The design axial load is P_u . Then the design procedure is the same as for short columns. The following example illustrate the design procedure of slender columns:

Example 8.6 Design a Column of Size 450 mm × 300mm using M30 concrete and Fe 415 steel. Given.

$$l_{ex} = 6.0 \text{ m}$$

$$l_{ey} = 5.5 \text{ m}$$

$$P_u = 1600 \text{ kN}$$

$$M_{ux} = 45 \text{ kN-m at top and } 30 \text{ kN-m at bottom.}$$

$$M_{uy} = 40 \text{ kN-m at top and } 25 \text{ kN-m at bottom.}$$

The column is bent in double curvature and assume a cover of 50 mm.

Solution:

$$\frac{l_{ex}}{D} = \frac{6000}{450} = 13.33 > 12$$

$$\frac{l_{ey}}{b} = \frac{5500}{300} = 18.33 > 12$$

Therefore the column is slender about both axes.

$$\frac{e_x}{D} = \frac{(13.33)^2}{2000} = 0.089$$

$$\frac{e_y}{D} = \frac{(18.33)^2}{2000} = 0.168$$

Hence, the additional moments are

$$M_{ax} = P_u e_x = 16000 \times 0.089 \times 450 = 64080 \text{ kN-mm} = 64.080 \text{ kN-m}$$

$$M_{ay} = P_u e_y = 1600 \times 0.168 \times 300 = 80.667 \times 103 \text{ kN-mm.}$$

$$= 80.667 \text{ kN-m}$$

For further calculation, we have to proceed with assumed percentage of reinforcement. As a first trial let. $p = 3.0$. Then

$$A_g = 450 \times 300 = 135000 \text{ mm}^2$$

$$A_{sc} = 450 \times 300 \times \frac{3}{100} = 4050 \text{ mm}^2$$

$$A_c = 135000 - 4050 = 130950 \text{ mm}^2$$

$$P_{uz} = 0.45 f_{ck} A_c + 0.75 \times f_y A_{sc}$$

$$= 0.45 \times 30 \times 130950 + 0.75 \times 415 \times 4050$$

$$= 3028387 \text{ N} = 3028.39 \text{ kN}$$

Calculation of P_b

$$\text{Cover} = 50 \text{ mm.}$$

$$\frac{d'}{D} = \frac{50}{450} = 0.111$$

∴ Chart corresponding to $\frac{d'}{D} = 0.15$ will be referred

$$\frac{d'}{D} = \frac{50}{300} = 1.667$$

∴ chart corresponding to $\frac{d'}{D} = 0.20$ will be referred

From table 8.2 (SP-16), we get

$$\frac{P_{bx}}{f_{ck}bD} = 0.196 + 0.203 \times \frac{3}{30} = 0.2136$$

$$\therefore P_{bx} = 0.2136 \times 30 \times 300 \times 450 = 876015 \text{ N} \\ = 879.015 \text{ kN}$$

Similarly

$$\frac{P_{by}}{f_{ck}bD} = 0.184 + 0.028 \times \frac{3}{30} = 0.1868$$

$$\therefore P_{by} = 0.1868 \times 30 \times 300 \times 450 = 756540 \text{ N} \\ = 756.540 \text{ kN.}$$

Hence the reduction factors for additional moments are,

$$k_x = \frac{P_{uz} - P_u}{P_{uz} - P_{bx}} = \frac{3028.390 - 1600}{3028.390 - 876.015} = 0.6636$$

$$k_y = \frac{P_{uz} - P_u}{P_{uz} - P_{by}} = \frac{3028.390 - 1600}{3028.390 - 756.540} = 0.6287$$

$$\therefore M_{ax} = 0.6636 \times 64.080 = 42.52 \text{ kN-m}$$

$$M_{ay} = 0.6287 \times 80.667 = 50.72 \text{ kN-m}$$

Initial moments to be considered

$$M_{ux1} = 0.6 \times 45 - 0.4 \times 30 = 15 \text{ kN-m}$$

$$M_{uy1} = 0.6 \times 40 - 0.4 \times 25 = 14 \text{ kN-m}$$

Initial moments from the consideration of minimum eccentricity

$$e_x = \frac{l}{500} + \frac{D}{30} = \frac{6000}{500} + \frac{450}{30} = 27 \text{ mm} > 20 \text{ mm.}$$

$$e_y = \frac{5500}{500} + \frac{300}{30} = 21 \text{ mm} > 20 \text{ mm.}$$

$$M_{ux1} = 1600 \times 27 = 43200 \text{ kN-mm} = 43.20 \text{ kN-m} > 15 \text{ kN-m.}$$

$$M_{uy1} = 1600 \times 21 = 33600 \text{ kN-mm} = 33.600 \text{ kN-m} > 14 \text{ kN-m}$$

$$\therefore M_{ux1} = 43.20 \text{ kN-m and } M_{uy1} = 33.60 \text{ kN-m.}$$

Hence the design moments are

$$M_{ux} = M_{ax} + M_{ux1} = 42.52 + 43.20 = 85.72 \text{ kN-m.}$$

$$M_{uy} = M_{ay} + M_{uy1} = 50.72 + 33.60 = 84.32 \text{ kN-m.}$$

Check for Biaxial Bending

$$\frac{P_u}{f_{ck}bD} = \frac{1600 \times 1000}{30 \times 300 \times 450} = 0.395$$

$$\frac{d'}{D} = 0.15 \text{ for } M_{ux} \text{ calculation and } 0.2 \text{ for } M_{uy} \text{ calculation.}$$

$$\frac{p}{f_{ck}} = \frac{3}{30} = 0.1$$

Hence referring to chart 45 in SP-16.

$$\frac{M_{ux}}{f_{ck}bD^2} = 0.11$$

$$\therefore M_{ux} = 0.11 \times 30 \times 300 \times 450^2 = 200.475 \times 10^6 \text{ N-mm.}$$

$$\text{i.e. } M_{ux} = 200.479 \text{ kN-m}$$

Referring to chart 46.

$$\frac{M_{uy}}{f_{ck}bD^2} = 0.1$$

$$\therefore M_{uy} = 0.1 \times 30 \times 450 \times 300 \times 300 = 121.5 \times 10^6 \text{ N-mm.}$$

$$= 121.5 \text{ kN-m.}$$

$$\frac{P_u}{P_{uz}} = \frac{1000}{3028.39} = 0.528$$

$$\therefore \alpha_n = 1 + \frac{0.528 - 0.2}{0.6} = 1.547$$

Hence the interaction formula gives,

$$\left(\frac{85.72}{200.475} \right)^{1.547} + \left(\frac{84.32}{121.5} \right)^{1.547}$$

$$= 0.836, \text{ which is less than one.}$$

Hence the design is safe

Main Reinforcement

$$p = 3$$

$$A_{sc} = \frac{3}{100} \times 300 \times 450 = 4050 \text{ mm}^2$$

Provide 12 bars of 22 mm diameter

$$A_{sc} \text{ provided} = 4561 \text{ mm}^2$$

Lateral Ties

Diameter: $\frac{1}{4} \times 22 = 5.5$ Use 6 mm ties.

Spacing. Not more than

(a) least lateral dimension – 300 mm.

(b) $16 \times 22 = 352$ mm

(c) 300 mm.

\therefore Provide 6 mm ties at 300 mm c/c. as shown in Fig. 8.17

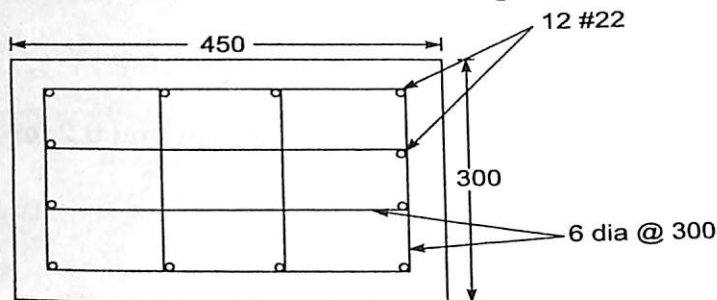

Fig. 8.17.

QUESTIONS

1. Design a short axial column of effective length 3 m to carry an axial load of 1600 kN. Use M25 concrete and Fe 415 steel.
2. A R.C.C. square column is to be designed to carry a factored load of 2400 kN. The reinforcement is to be restricted to 2% of gross area. Adopting M25 concrete and Fe - 415 steel, design the column. The column may be considered as short.
3. Design a R.C. circular column section to carry a factored load of 2400 kN. Provide helical reinforcements as transverse reinforcements. Adopt M20 concrete and Fe - 415 steel.
4. Determine the reinforcement to be provided in a square column 300 mm x 300 mm subject to uniaxial bending with the following data:

Factored load	= 1000 kN
Factored bending moment	= 120 kN-m
Grade of concrete	= M20
Grade of steel	= Fe - 415

The reinforcement is to be provided on four faces equally. Use SP - 16.
5. Determine the reinforcement required for a short column subjected to biaxial bending, using the following data:

Cross section of the column	: 400 mm x 600 mm
Concrete Mix	: M 20
Steel	: Fe - 415
Factored load P_u	= 1800 kN
Factored moment acting parallel to the larger dimension M_{ux}	= 160 kN-m
Factored moment acting parallel to the shorter dimension M_{uy}	= 120 kN-m.

Use of SP - 16 permitted.
6. Design a short column 450 mm square in section to carry an axial load of 800 kN with moments of 60 kN-m and 40 kN-m about two axis at working loads. Assume M20 concrete and Fe - 415 steel. Use of SP - 16 permitted.
7. A square column 500 mm x 500 mm is reinforced with 2.4% steel. It is subjected to a factored load of $P_u = 2000$ kN and moments $M_{ux} = M_{uy} = 200$ kN-m. Check the adequacy of the section adopting M20 concrete and Fe - 415 steel. The effective cover to steel may be taken as 50 mm and steel is to be provided equally on all the four sides.

Design of Isolated Column Footings

9.1 INTRODUCTION

Footings of walls and columns transfer the load of superstructure to soil. The footing may rest on soil directly or may transfer the load through piles. In this Chapter the design of footings directly resting on soils is discussed. Load bearing capacity of masonry or concrete walls and columns is much higher than that of soil. Hence they can not be made to rest directly on the soil. The load from superstructure is to be spread to wider area so that load on soil is within the safe bearing capacity of the soil. The footing does this job of spreading the load over wider area. In doing this job, the footing itself is subjected to bending moment and shear force.

Footing may be of masonry, plain concrete or of R.C. C. In case of plain concrete footings the dispersion angle of load is 45° as shown in Fig. 9.1.

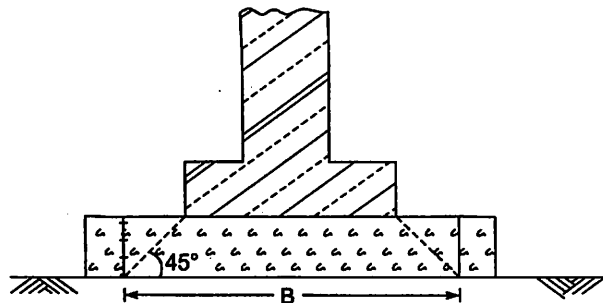

Fig. 9.1. Dispersion in Plain Concrete Footing.

9.2 TYPES OF R.C.C. FOOTINGS

There are mainly two types of footings

- (a) One way reinforced footings
- (b) Two way reinforced footing

(a) One Way Reinforced Footings:

These footings are for walls. In case of masonry walls footing, the footing may be designed as a cantilever of span

$$l = \frac{B}{2} - \frac{b_w}{4}$$

where B is the width of footing
and b_w is width of wall as shown in Fig. 9.2.

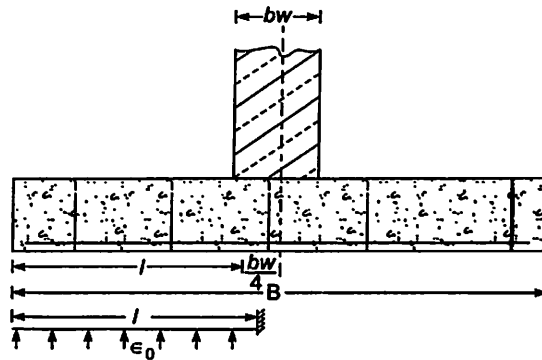

Fig. 9.2. Cantilever span for R.C.C. Footing of a wall.

In case of concrete walls, the footing is designed as a cantilever of span

$$l = \frac{B}{2} - \frac{b_w}{2}, \text{ as shown in Fig. 9.3.}$$

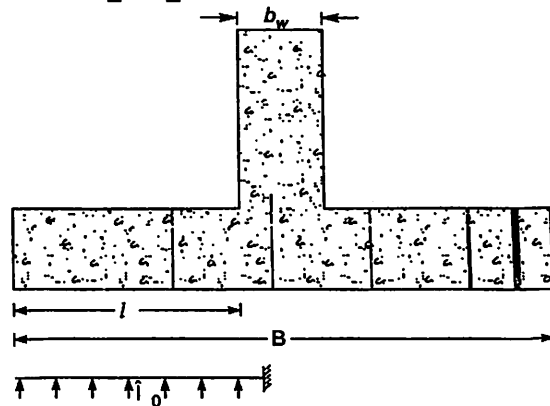

Fig. 9.3. Cantilever span for R.C.C. Footing of R.C.C. wall

(b) Two Way Reinforced Footings :

For all R.C.C. columns two way reinforced footings are provided. The following types of the footings are commonly used:

(i) **Isolated Column Footings:** For each column a separate footing is provided as shown in Fig. 9.4.

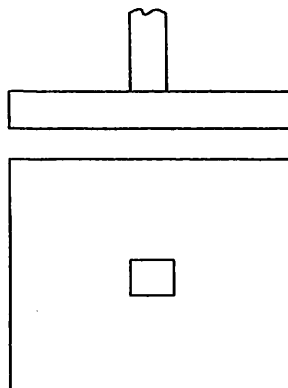

Fig. 9.4. Isolated column Footing.

(ii) **Combined Footings:** Common footing may be provided for two columns. This type of footing is usually preferred when the column is very close to boundary of the property and hence there is no scope to project footing much beyond the column face. Such footing is shown in Fig. 9.5.

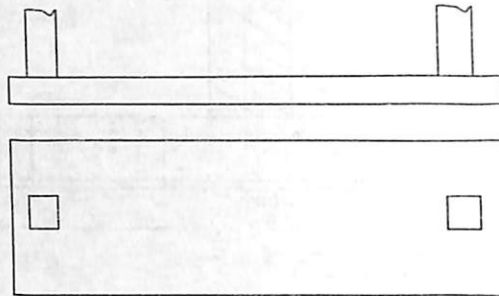

Fig. 9.5. Combined Footing

(iii) **Raft Footing:** If the load on the columns is quite high or when SBC of soil is low, the sizes of isolated columns may work out to such extent that the footings of adjacent columns overlap. In such cases for all columns a common footing may be provided as shown in Fig. 9.6. Such footing are known as raft footing

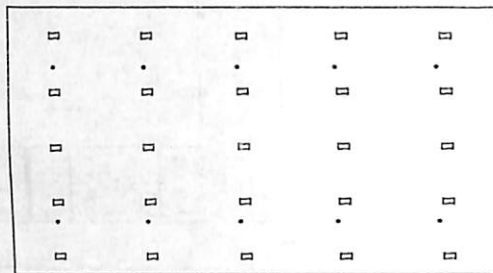

Fig. 9.6. Raft Footing.

9.3 LOAD FOR FOUNDATION

The loads to be used to determine the size of the footings should be on the serviceability conditions and not on the limit state of collapse conditions. Thus for

- (a) Dead load plus imposed case, $1.0 \text{ DL} + 1.0 \text{ IL}$
- (b) Dead load plus wind load case, $1.0 \text{ DL} + 1.0 \text{ WL}$
- (c) Dead + Imposed + Wind load case, $1.0 \text{ DL} + 0.8 \text{ IL} + 0.8 \text{ WL}$

10 percent of load from column may be taken as self weight of footing for determining the area of footing required. However it is to be noted that self weight directly get transferred to soil without creating any bending moment and shear force in the footing.

In case of multistory buildings, one should take advantage of the allowable reduction in the live load for residential and office buildings.

9.4 DEPTH OF FOOTING

Rankine's formula is used to determine the minimum depth of foundation. The formula is as given below:

$$h = \frac{p}{w} \left[\frac{1 - \sin \phi}{1 + \sin \phi} \right]^2$$

where h = minimum depth
 p = safe bearing capacity
 w = unit weight of soil and
 ϕ = Angle of friction of soil

9.5 COVER

If plain concrete bed is provided, the minimum cover to main reinforcement shall be 50 mm. If plain concrete bed is not provided minimum cover to main reinforcement shall be 75 mm.

9.6 MINIMUM THICKNESS

Theoretically, the thickness required at the edges of footings is zero, since at free edge the bending moment and shear force are zero. However to take care of accidental situations and the requirement of cover, IS 456 prescribes the following minimum thickness:

For footings on soil – 150 mm
 For footings on piles – 300 mm

9.7 MINIMUM REINFORCEMENT

The minimum reinforcement described for slab and beams are applicable for footings also. Minimum diameter of bar to be used is 10mm.

9.8 DESIGN OF ISOLATED COLUMN FOOTINGS SUBJECTED TO AXIAL LOADS

Isolated column footings are usually square or rectangular shape. They may have uniform thickness throughout or may have sloping top. The design procedure for footings is explained and illustrated in this article.

9.8.1 Design of Square Footing with Uniform Thickness

Let the axial load transferred by column be P .

Step 1: Size of footing

Add 10% of P as self weight of footing.

$$\therefore \text{Load on the soil} = P + \frac{P}{10} = 1.1P$$

Area of footing required,

$$A = \frac{1.1 P}{\text{SBC of soil}}$$

∴ Size of footing,

$$B = \sqrt{A}$$

This is rounded to next – higher multiple of 100 mm size.

Step 2: Determine the soil reaction for the factored load.

$$q_u = \frac{P_u}{A} = \frac{1.5P}{A}$$

Step 3: Determine the minimum depth required from the consideration of

- (a) bending moment
- (b) single shear
- (c) double shear

(a) **From consideration of bending moment:**

Critical section from the consideration of moment is at the face of the column (see Fig. 9.7).

Projection of the footing = $\frac{B-b}{2}$. Hence the bending moment about $x-x$ is,

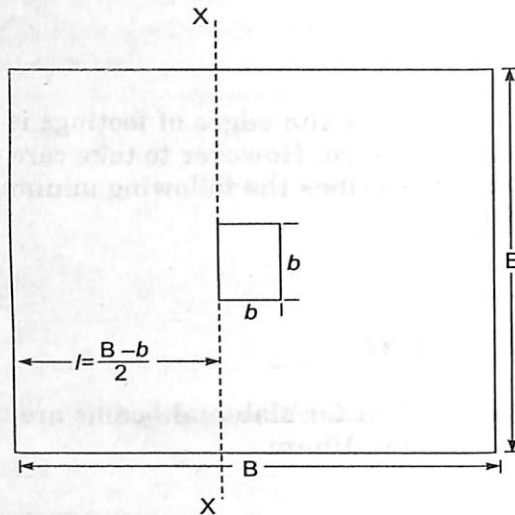

Fig. 9.7. Critical Section for moment.

$$M_u = q_u \left(\frac{B-b}{2} \right) \frac{1}{2} \left(\frac{B-b}{2} \right) = q_u \frac{(B-b)^2}{8} = \frac{q_u \ell^2}{2}$$

where $\ell = B - b$, the projection

Minimum depth required is obtained by treating above moment as limiting moment.

$$\begin{aligned} M_u &= 0.36 f_{ck} x_{u \text{ lim}} (d - 0.42 x_{u \text{ lim}}) \\ &= 0.36 f_{ck} \frac{x_{u \text{ lim}}}{d} \left(1 - \frac{0.42 x_{u \text{ lim}}}{d} \right) b d^2 \\ &= 0.148 f_{ck} b d^2, \text{ for mild steel} \\ &= 0.138 f_{ck} b d^2, \text{ for Fe 415 steel} \\ &= 0.133 f_{ck} b d^2, \text{ for Fe 500 steel} \end{aligned}$$

(b) Minimum Depth from the Consideration of One Way Shear:

For this critical section is at a distance ' d ' from the face of the column as shown in Fig. 9.8.

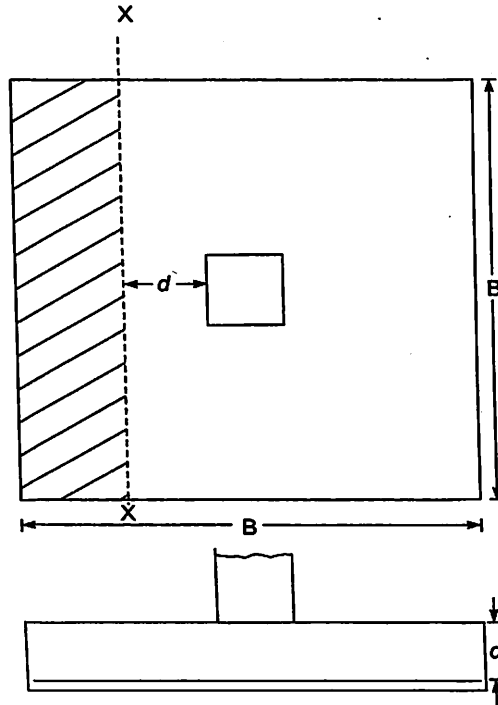

Fig. 9.8. Critical Section For One way shear.

Design shear

V_u = soil pressure from shaded area

$$= q_u B \left[\frac{B-b}{2} - d \right]$$

$$\therefore \tau_v = \frac{V_u}{Bd}$$

This value should not be more than τ_c , the critical shear stress in concrete. Hence the minimum depth required from the consideration of one way shear is given by

$$\tau_c B d = q_u B \left[\frac{B-b}{2} - d \right]$$

However at this stage τ_c is not known, since percentage steel is not known. τ_c may be assumed as that corresponding to 0.2% steel which is the minimum value given in Sp-16 or which may be obtained by interpolating between the values corresponding to $p = 0.15$ to 0.25 as given in Table 19 of IS 456. If we refer to SP-16 τ_c for M20 may be taken as 0.33 N/mm^2 or by referring to IS 456 it may be taken as 0.32 N/mm^2 .

(c) Depth from the Consideration of Two Way Shear:

Two way shear is also known as punching shear. If footing depth is less, the column may punch through the footing. For this tendency, IS 456 recommends that critical section is at a distance $\frac{d}{2}$ from the column face. Referring to Fig. 9.9, perimeter of punching shear area

$$= 4(b + d)$$

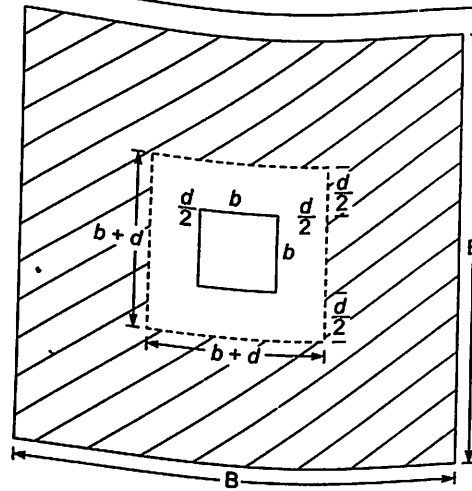

Fig. 9.9.

∴ Area of concrete resisting punching force

$$A = 4(b + d)d$$

Force of punching S is given by

$$S = q_u \times \text{shaded Area}$$

$$= q_u [B^2 - (b + d)^2]$$

∴ Punching shear stress τ_p is given by

$$\tau_p = \frac{S}{A}$$

Permissible value is

$$\tau_p = 0.25 \sqrt{f_{ck}}$$

In case of footings with uniform thickness, usually one way shear governs the depth, the other two cases may be used for checking the depth selected.

Step 4: Determine the area of reinforcement required in width B using the expression

$$M_u = 0.87 f_y A_{st} d \left[1 - \frac{A_{st} f_y}{bd f_{ck}} \right]$$

Using the bars of diameter not less than 10mm, determine spacing of bars.

$$s = \frac{\pi/4 \phi^2}{A_{st}} \times B$$

Provide the reinforcements in both directions.

Step 5: Check for bond length

Since the footing is designed as a cantilever with reinforcements subjected to designed strength at the column face, sufficient bond length should be available from the face of the column

$$L_d = \frac{0.87 f_y \phi}{4 \tau_{bd}}$$

Step 6: Sketch the reinforcement detail

Example 9.1. Design a square footing for a short axially loaded column of size 300mm × 300mm carrying 600kN load. Use M20 concrete and Fe 415 steel. SBC of soil is 180 kN/m². Sketch the details of reinforcement.

Solution:

1. Size of Footing:

$$P = 600 \text{ kN}$$

$$\text{Self weight} = \frac{600}{10} = 60 \text{ kN}$$

$$\therefore \text{Total load} = 660 \text{ kN}$$

$$SBC = 180 \text{ kN/m}^2$$

\therefore Area of footing

$$A = \frac{660}{180} = 3.667 \text{ m}^2$$

$$\therefore \text{Size of footing} = 1.91 \times 1.91 \text{ m}$$

Provide 2m × 2m footing

2. Soil reaction for the factored load:

$$q_u = \frac{1.5P}{B \times B} = \frac{1.5 \times 600}{2 \times 2} = 225 \text{ kN/m}^2$$

$$= 0.225 \text{ N/mm}^2$$

3. Depth of footing:

From the consideration of shear, depth will be found and checked for two way shear and bending.

The critical section is at a distance 'd' from the face of the column as shown in Fig. 9.10.

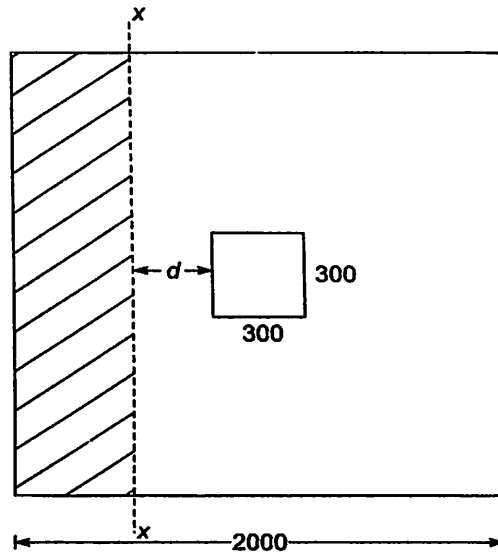

Fig. 9.10.

V_u = Soil pressure from shaded area

$$= q_u B \left(\frac{B-b}{2} - d \right)$$

$$= 0.225 \times 2000 \left[\frac{2000 - 300}{2} - d \right]$$

$$= 450[850 - d]$$

Assuming 0.2% steel, for M20 concrete

$$\tau_c = 0.32 \text{ N/mm}^2$$

∴ Minimum depth required is

$$0.32 \times 2000 \times d = 450[850 - d]$$

∴

$$d = 351 \text{ mm}$$

provide

$$d = 360 \text{ mm}$$

Check for Bending:

$$M_{u \text{ lim}} = 0.36 f_{ck} B x_{u \text{ lim}} (d - 0.42 x_{u \text{ lim}})$$

$$= 0.36 f_{ck} B \frac{x_{u \text{ lim}}}{d} \left(1 - \frac{0.42 x_{u \text{ lim}}}{d} \right) d^2$$

$$\frac{x_{u \text{ lim}}}{d} = 0.48$$

∴

$$M_{u \text{ lim}} = 0.138 f_{ck} b d^2$$

$$M_{u \text{ lim}} = 0.138 \times 20 \times 2000 \times 360^2 = 815.2 \times 10^6 \text{ N-mm}$$

M_u is to be calculated at the face of the column as shown in Fig. 9.11.

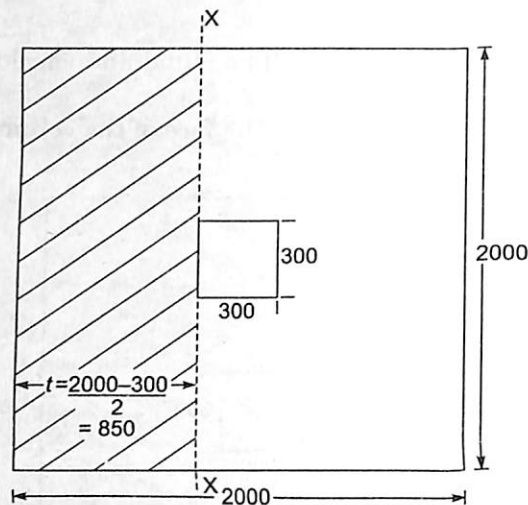

Fig. 9.11.

M_u = Moment of force under shaded area about section $x-x$

$$= q_u \frac{(B-b)^2}{8}$$

$$= 0.225 \times 2000 \frac{(2000 - 300)^2}{8}$$

$$= 162.563 \times 10^6 \text{ N-mm} < M_{u \text{ lim}}$$

∴ Depth provided is sufficient

Check for two way shear:

Critical section is at a distance $\frac{d}{2}$ from the face of column as shown in Fig. 9.12.

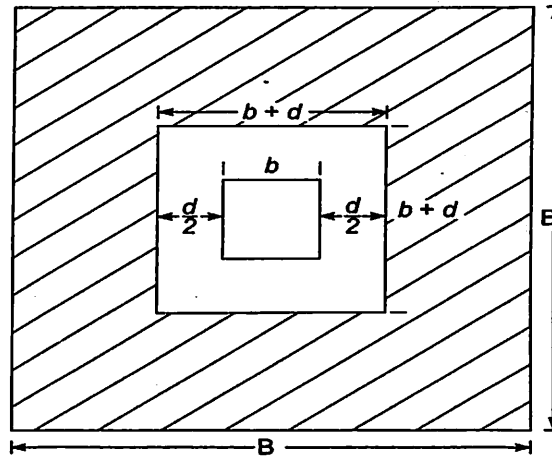

Fig. 9.12.

$$\begin{aligned} \therefore \text{Perimeter of critical section} &= 4(b + d) = 4(300 + 360) = 2640 \text{ mm} \\ \therefore \text{Area of critical section} &= 2640 d = 2640 \times 360 \\ \therefore \text{Two way shear stress} &= \frac{\text{Upward pressure in shaded area}}{\text{Area of Critical Section}} \\ &= \frac{0.225(2000 \times 2000 - 660 \times 660)}{2640 \times 360} \\ &= 0.844 \text{ N/mm}^2 \end{aligned}$$

Maximum shear stress permitted

$$\begin{aligned} &= 0.25\sqrt{f_{ck}} = 0.25\sqrt{20} \\ &= 1.118 \text{ N/mm}^2 \end{aligned}$$

\therefore Depth of 360mm is sufficient from the consideration of two way shear.

Step 4:

$$M_u = 162.563 \times 10^6 \text{ N-mm over a width of 2000mm}$$

$$\therefore 162.563 \times 10^6 = 0.87 \times 415 \times A_{st} \times 360 \left[1 - \frac{A_{st}}{2000 \times 360} \times \frac{415}{20} \right]$$

$$1250.7 = A_{st} \left[1 - \frac{A_{st}}{34699} \right]$$

$$A_{st}^2 - 34699 A_{st} + 1250.7 \times 34699 = 0$$

$$\begin{aligned} \therefore A_{st} &= \frac{34699 - \sqrt{34699^2 - 4 \times 1250.7 \times 34699}}{2} \\ &= 1299 \text{ mm}^2 \end{aligned}$$

190 Design of R.C.C. Structural Elements

Using 12mm bars, spacing

$$S = \frac{\pi/4 \times 12^2}{1299} \times 2000$$

[since above area is required in 2000 mm width]
= 174 mm

Provide 12mm bars at 170mm c/c

$$p_t \text{ provided} = \frac{\pi/4 \times 12^2}{170 \times 360} \times 100 = 0.185$$

∴ τ_c from table 19 of IS 450

$$\tau_c = 0.28 + [0.36 - 0.28] \times \frac{0.035}{0.10} = 0.308$$

$$\tau_v = \frac{V_u}{Bd} = \frac{0.225 \times 2000 \left[\frac{2000 - 300}{2} - 360 \right]}{2000 \times 360}$$

$$= 0.306 \text{ N/mm}^2 < \tau_c \text{ OK}$$

Step 5: Development Length

τ_{bd} for M20 concrete & Fe 415 steel = $1.2 \times 1.6 = 1.92$ [clause 26.2.1.1 in IS 456]

$$L_d = \frac{0.87 f_y \phi}{4 \tau_{bd}} = \frac{0.87 \times 415 \times 12}{4 \times 1.92} = 564 \text{ mm}$$

This much length is available beyond column face. Hence O.K.
Reinforcement details are shown in Fig. 9.13.

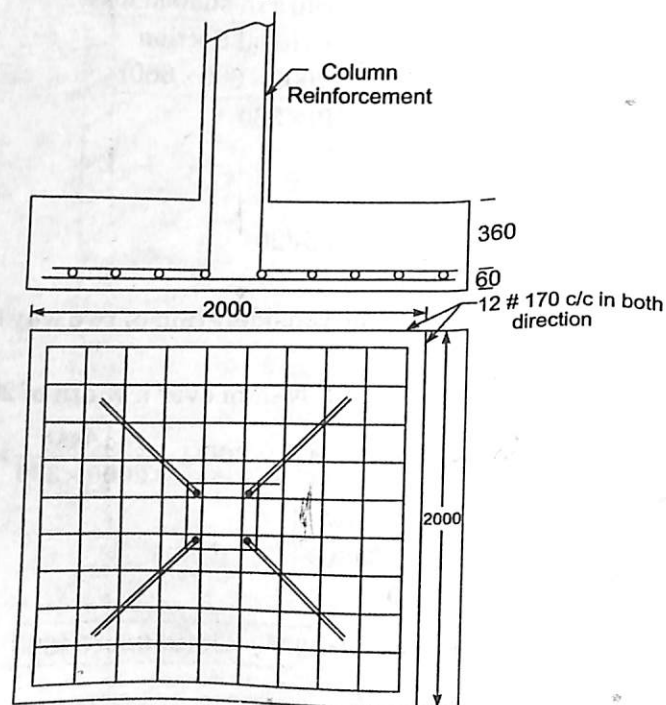

Fig. 9.13.

9.8.2 Design of Footing with Uniform Thickness for Rectangular Columns

For rectangular columns, economical design of footing is obtained if the projection of footing in both directions is same. Then design can be carried out similar to square footing for square column and the same reinforcement is provided in other direction also. This case is illustrated with example 9.2.

Example 9.2. A rectangular column $400\text{mm} \times 600\text{mm}$ carries a live load of 2000 kN . The safe bearing capacity of the soil is 150 kN/m^2 . Using M20 concrete and Fe 415 steel, design a rectangular footing to support the column. Sketch the details of the reinforcement.

Solution :

Area of Footing:

Load from column	$P = 2000\text{ kN}$
Self weight	$= 200\text{ kN}$
Total load on soil	$= 2200\text{ kN}$
	$SBC = 150\text{ kN/m}^2$

$$\therefore A = \frac{2200}{150} = 14.667\text{ m}^2$$

Provide $3.8\text{ m} \times 4.0\text{ m}$ footing.

$$\therefore \text{Area provided} = 3.8 \times 4 = 15.2\text{ m}^2$$

Soil Pressure for Design :

$$q_u = 1.5 \times \frac{2000}{15.2} = 197.4\text{ kN/m}^2$$

$$= 0.1974\text{ N/mm}^2$$

Cantilever projection $l = \frac{3.8 - 0.4}{2} = 1.7\text{ m}$, as shown in Fig. 9.14.

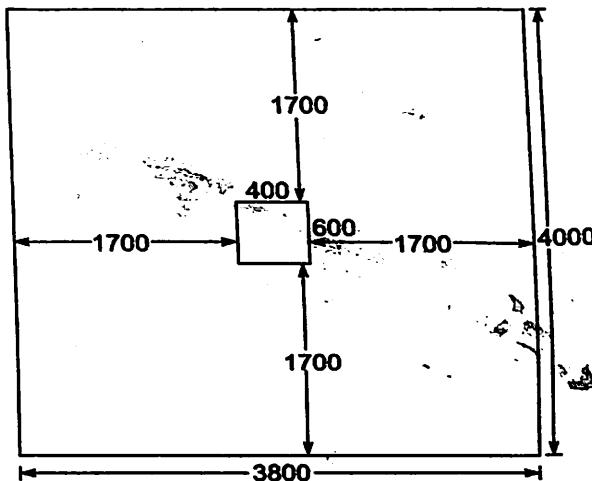

Fig. 9.14. Plan of Footing.

Depth of Footing:

Critical section for one way shear is as shown in Fig. 9.15.

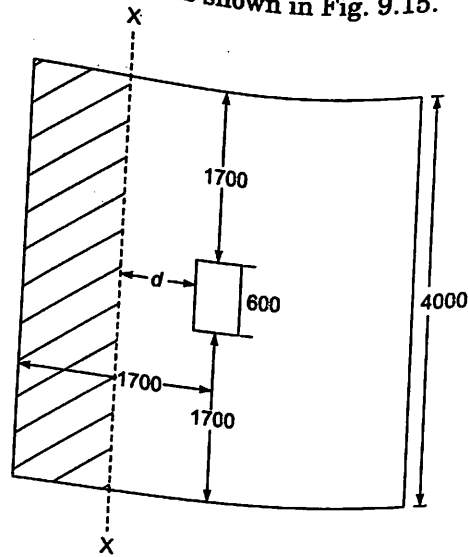

Fig. 9.15. Critical section for one way shear.

Total shear force across section $x - x$

$$V_u = q_u \times \text{shaded area} = 0.1974 \times 4000 (1700 - d)$$

Assuming

$$p_t = 0.20, \tau_c \text{ for M20 concrete} = 0.32 \text{ N/mm}^2$$

Let depth of footing be d . Then equating applied shear to resisting shear, we get

$$0.1974 \times 4000 (1700 - d) = 0.32 \times 4000 d$$

\therefore

$$d = 648 \text{ mm}$$

Provide

$$d = 650 \text{ mm and } D = 725 \text{ mm}$$

Check for Bending:

Critical section is at the face of the column as shown in Fig. 9.16.

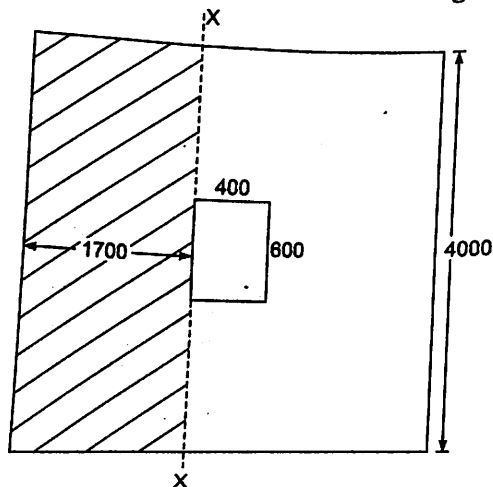

Fig. 9.16. Critical section for moment.

M_u for 4000 mm width is given by

$$\begin{aligned} M_u &= 0.1974 \times 4000 \times 1700 \frac{1700}{2} \\ &= 114.972 \times 10^6 \text{ N-mm} \\ x_{u \text{ lim}} &= 0.48 \times 50 = 312 \\ M_{u \text{ lim}} &= 0.36 \times 20 \times 4000 \times 312 (650 - 0.42 \times 312) \\ &= 4663.16 \times 10^6 \text{ N-mm} > M_u \end{aligned}$$

\therefore Depth selected is sufficient to design footing as singly reinforced section
Check for Depth from the Consideration of Two Way Shear:

The critical section is at a distance $\frac{d}{2} = \frac{650}{2} = 325$ mm from the face of the column as shown in Fig. 9.17.

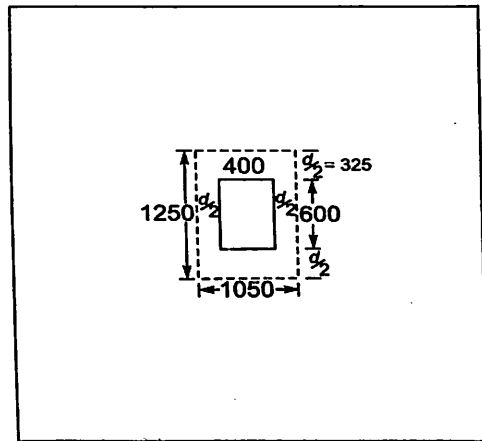

Fig. 9.17. Critical section for two way shear.

Perimeter of this section

$$\begin{aligned} &= 2(400 + 650 + 600 + 650) = 2(1050 + 1250) \\ &= 4600 \text{ mm} \end{aligned}$$

\therefore Area of concrete resisting two way shear

$$= 4600 \times 650 = 2990000 \text{ mm}^2$$

Punching shear

$$\begin{aligned} V_u &= 0.1974 [4000 \times 3800 - 1050 \times 1250] \\ &= 2741392 \text{ N} \end{aligned}$$

Equating it to resisting shear, we get

$$\begin{aligned} 2741392 &= 2990000 \tau'_c \\ \tau'_c &= 0.917 \text{ N/mm}^2 \end{aligned}$$

Two way shear stress permitted [clause 31.6.3.1]

$$= k_s \tau_c$$

where $k_s = 0.5 + \beta_c$ but not greater than 1,
 β_c being the ratio of smaller to larger side

since $\beta_c = \frac{3.8}{4} = 0.95$

$\therefore k_s = 1$

$\therefore \tau_c = 10.25\sqrt{f_{ck}} = 0.25\sqrt{20} = 1.118 \text{ N/mm}^2$

But actual $\tau_c = 0.917 \text{ N/mm}^2$

\therefore Footing is safe in two way shear

Depth selected $d = 650 \text{ mm}$

Reinforcement:

$$M_u = 0.87 f_y A_{st} d \left[1 - \frac{A_{st} f_y}{bd f_{ck}} \right]$$

$$1140.972 \times 10^6 = 0.87 \times 415 A_{st} \times 650 \left[1 - \frac{A_{st}}{4000 \times 650} \times \frac{415}{20} \right]$$

$$4861.8 = A_{st} \left[1 - \frac{A_{st}}{125301} \right]$$

$$\therefore A_{st}^2 - 125301 A_{st} + 4861.8 \times 125301 = 0$$

$$A_{st} = \frac{125301 - \sqrt{125301^2 - 4 \times 4861.8 \times 125301}}{2}$$

$$= 5068 \text{ mm}^2, \text{ to be provided in } 4000 \text{ mm width}$$

Using 12mm bars,

$$s = \frac{\pi/4 \times 12^2}{5068} \times 4000 = 89.3, \text{ too close}$$

Try 16mm bars

$$s = \frac{\pi/4 \times 16^2}{5068} \times 4000 = 158.1 \text{ mm}$$

Provide 16mm bars at 150mm c/c in both directions

$$p_t = \frac{\pi/4 \times 16^2}{150 \times 650} \times 100 = 0.206 > 0.2 \text{ assumed for taking } \tau_c.$$

Hence O.K.

Check for Development Length:

$$L_d = \frac{0.87 f_y \phi}{4 \tau_{bd}}, \tau_{bd} \text{ for M20 concrete and Fe 415 steel} = 1.92 \text{ N/mm}^2 \text{ [Clause 26.2.1.1 in IS 456]}$$

$$L_d = \frac{0.87 \times 415 \times 16}{4 \times 1.92} = 752 \text{ mm} < 1700 \text{ mm}$$

Hence development length is available

Details of Reinforcement are shown in Fig. 9.18.

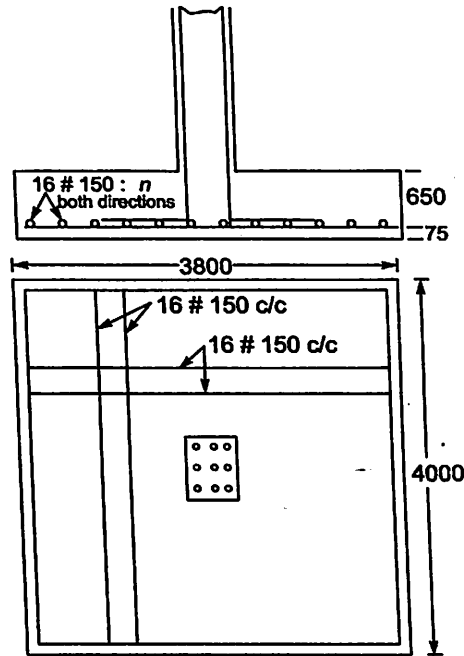

Fig. 9.18.

9.8.3 Design of Rectangular Footing with Uniform Thickness

Some times the boundary of property line restricts one side of footing. In such cases we may have to go for rectangular footings with unequal projections. The depth of footing is to be based on longer projection. Such footings require design of bars in the two directions separately. In the long direction reinforcement is placed uniformly. But in short direction, IS 456 (Clause 34.3.1.c) recommends more steel near the column. For this, a column band equal to the shorter side of footing is marked as shown in Fig. 9.19. Number of bars in this band shall be

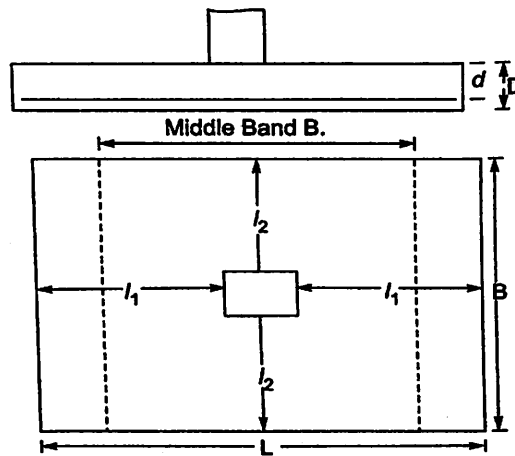

Fig. 9.19. Middle Band of Rectangular Footing.

$$\frac{2}{\frac{L}{B} + 1} n$$

where L = Long side of footing
 B = Short side of footing
 n = Number of bars required in long side

Example 9.3. Design a footing for a column of size $400 \times 400\text{mm}$ which carries a load of 800kN . SBC of soil is 200 kN/m^2 . Use M20 concrete and Fe 415 steel. One side of footing is to be restricted to 1.5m .

Solution :

Size of footing:

$$\begin{aligned} \text{Self weight} & P = 800 \text{ kN} \\ \text{Load on soil} & = 80 \text{ kN} \\ & \underline{\hspace{1.5cm}} \\ & = 880 \text{ kN} \\ \text{SBC} & = 200 \text{ kN} \\ \therefore A & = \frac{880}{200} = 4.4 \text{ m}^2 \\ \text{Since one side is } 1.5\text{m, the other side is} & \\ & = \frac{4.4}{1.5} = 2.93 \text{ m} \end{aligned}$$

Provide $1.5\text{m} \times 3\text{m}$ footing

The footing is as shown in Fig. 9.20.

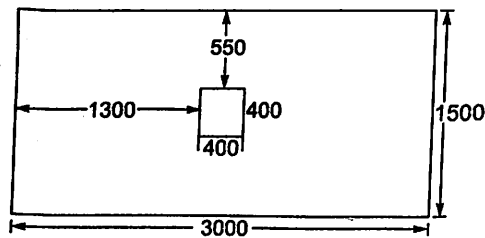

Fig. 9.20. Size of the Footing.

Soil Pressure for Design

$$q_u = 1.5 \times \frac{800}{1.5 \times 3.0} = 267 \text{ kN/m}^2 = 0.267 \text{ N/mm}^2$$

Depth of Footing

For one way shear, the critical section is at distance ' d ' from the face of the column as shown in Fig. 9.21.

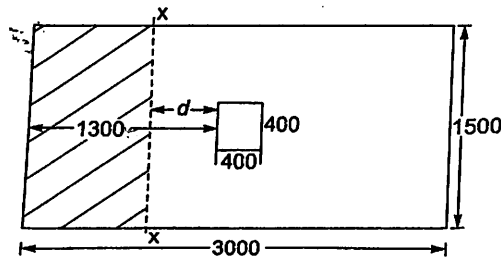

Fig. 9.21. Critical Section For One way Shear.

Assuming permissible shear is 0.32 N/mm^2 and equating resisting shear to shear force at critical section, we get

$$0.32 \times 1500 \times d = 0.267 \times 1500 (1300 - d)$$

$$d = 591.3 \text{ mm}$$

Provide

$$d = 600 \text{ mm} \text{ and } D = 650 \text{ mm}$$

Check for Depth from Bending Consideration:

The critical section is at the face of the column as shown in Fig 9.22. At this section,

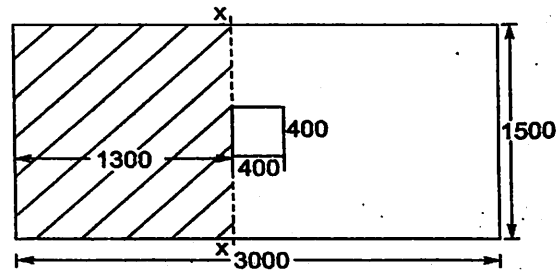

Fig. 9.22. Critical Section for Bending.

$$M_u = 0.267 \times 1500 \times 1300 \times \frac{1300}{2} = 338.423 \times 10^6 \text{ N-mm}$$

$$x_{u \text{ lim}} = 0.48 d = 0.48 \times 600 = 288 \text{ mm}$$

\therefore

$$M_{u \text{ lim}} = 0.36 \times 20 \times 1500 \times 288 (600 - 0.42 \times 288) = 1490.0 \times 10^6 \text{ N-mm}$$

Thus $M_u < M_{u \text{ lim}}$

Hence depth selected is sufficient from bending consideration.

Check for Depth from the Consideration of Two Way Shear:

The critical section is as shown in Fig. 9.23.

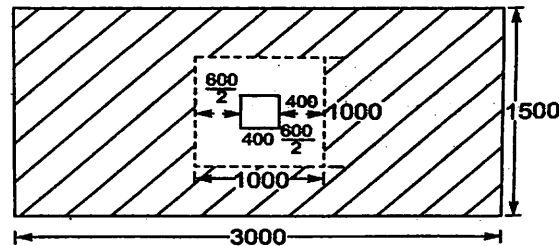

Fig. 9.23. Critical Section For Two way Shear.

Perimeter of resisting section

$$= 4[400 + 600] = 4000 \text{ mm}$$

Resisting area

$$= 4000 d = 4000 \times 600 = 2400000 \text{ mm}^2$$

Punching (two way) shear force

$$= \text{Upward force from shaded area}$$

$$= 0.267 \times [3000 \times 1500 - 1000 \times 1000] = 934500 \text{ N}$$

\therefore Two way shear stress on the critical section

$$= \frac{934500}{2400000} = 0.389 \text{ N/mm}^2$$

Permissible stress [clause 31.6.3.1]

For this case, $= k_s \tau_c = k_s 0.25\sqrt{20} = 1.118 k_s \text{ N/mm}^2$

$$k_s = 0.5 + \frac{15}{30} = 1.0$$

\therefore Permissible two way shear = 1.118 N/mm²

Actual two way shear stress = 0.389 N/mm²

Hence depth provided is sufficient from the consideration of two way shear.

Design of Reinforcement

(a) **In Long Direction**

$$M_u = 338.423 \times 10^6 \text{ N-mm}$$

$$338.423 \times 10^6 = 0.87 \times 415 \times A_{st} \times 600 \left[1 - \frac{A_{st}}{1500 \times 600} \times \frac{415}{20} \right]$$

$$1562.2 = A_{st} \left[1 - \frac{A_{st}}{43373.5} \right]$$

$$\therefore A_{st}^2 - 43373.5 A_{st} + 1562.2 \times 43373.5 = 0$$

$$A_{st} = \frac{43373.5 - \sqrt{43373.5^2 - 4 \times 1562.2 \times 43373.5}}{2}$$

$$= 1623 \text{ mm}^2$$

Using 16 mm bars at

$$s = \frac{\pi/4 \times 16^2}{1623} \times 1500 = 185.8 \text{ mm}$$

Provide 16mm bars at 180mm c/c

(b) **In Short Direction:**

Projection of footing from the face of column = 550 mm

Width of section

$$= 3000 \text{ mm}$$

$$M_u = 0.267 \times 3000 \times \frac{550^2}{2} = 121.15 \times 10^6 \text{ N-mm}$$

$$d = 600 - 16 = 584 \text{ mm}$$

$$121.15 \times 10^6 = 0.87 \times 415 A_{st} \times 584 \left[1 - \frac{A_{st}}{3000 \times 584} \times \frac{415}{20} \right]$$

$$574.57 = A_{st} \left[1 - \frac{A_{st}}{84433.7} \right]$$

$$\therefore A_{st}^2 - 84433.7 A_{st} + 574.57 \times 84433.7 = 0$$

$$A_{st} = \frac{84433.7 - \sqrt{84433.7^2 - 4 \times 574.57 \times 84433.7}}{2}$$

$$= 579 \text{ mm}^2$$

The above area of steel is to be provided in a width of 3000 mm. Area of steel to be provided in the column band width of 1500 mm is,

$$A_{st1} = \frac{2}{\frac{L}{b} + 1} A_{st} = \frac{2}{\frac{3000}{1500} + 1} \times 579 = 386 \text{ mm}^2.$$

Minimum steel to be provided in this 1500 mm width, $A_{stmin} = \frac{0.12}{100} \times 1500 \times 650 = 1170 \text{ mm}^2$

> A_{st} reqd.

∴ Provide minimum reinforcement throughout Using 16 mm, spacing

$$S = \frac{\frac{\pi}{4} \times 16^2}{1170} \times 1500 = 257 \text{ mm.}$$

Provide 16 mm bars at 250 mm c/c throughout. The reinforcement detail is shown in Fig. 9.24.

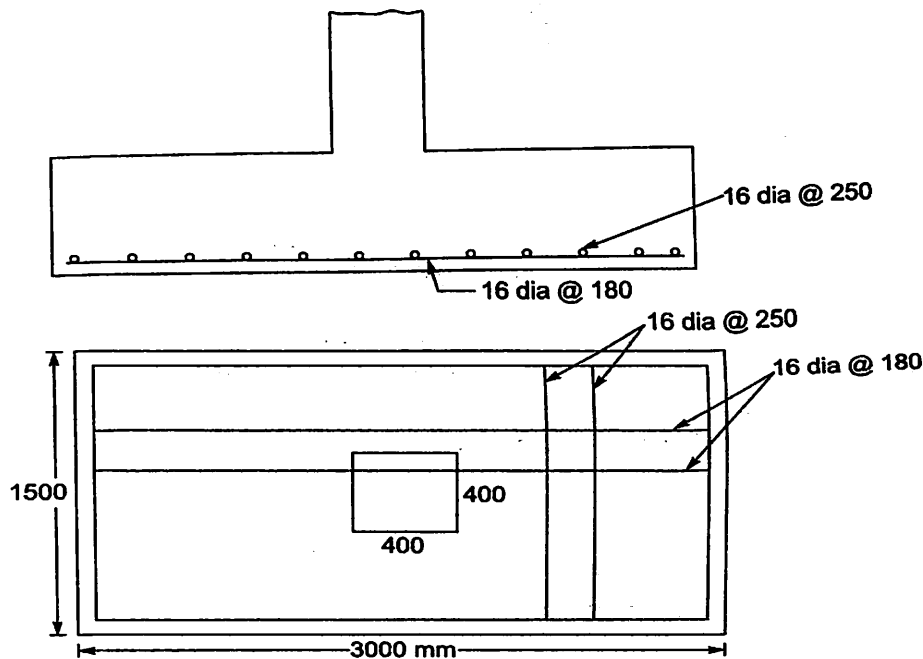

Fig. 9.24.

9.8.4 Design of Sloping Footing

We have seen that the critical sections in the footings are at or near the column faces and there is neither shear force nor bending moment at the edges. Hence to achieve economy, it is suggested that the depth of footing is kept more near column faces and reduced to minimum at the edges. For the simplicity of construction, the variation of depth is kept linear. As mentioned earlier, the minimum depth at free edges should be 150 mm for footings resting directly on the soil and 300 mm for the footings resting on piles.

The critical sections recommended for bending, one way shear and two way shears are the same as used for the design of footings with uniform thickness. The designer has to note that the cross sections at critical sections are not rectangular since the top surface is linearly reducing towards the edges. The calculation of one way and two way shear stresses is not difficult, since they depend directly on the area of cross section. Calculation of bending stresses is bit difficult since it depends upon the moment of inertia of the section which is trapezoidal. To simplify the design of the section for bending, two completely different suggestions can be seen in the literature. These methods are briefly explained below:

(i) **Method 1:** Find bending moment corresponding to the pressure under shaded trapezoidal area in Fig. 9.25 about the column face.

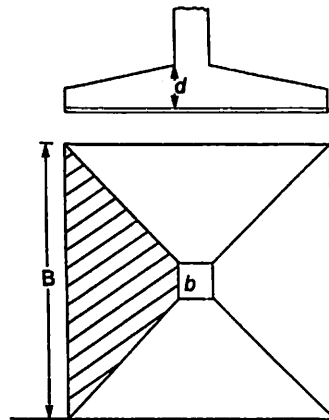

Fig. 9.25.

Assuming this moment is resisted by the footing of width equal to that of column determine the reinforcement required. Provide this reinforcement over entire width.

(ii) **Method 2:** Determine the bending moment due to the pressure under shaded area shown in Fig. 9.26 about the critical section $x-x$ at column face.

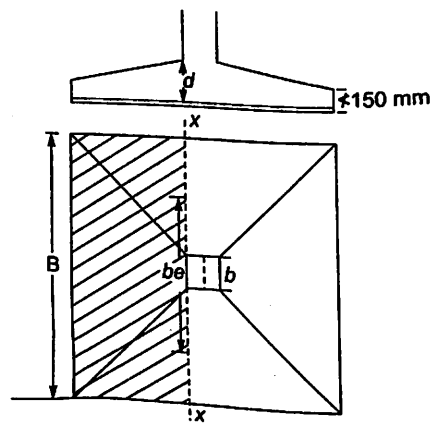

Fig. 9.26.

Assuming it to be resisted by footing of width $b_e = \text{width of column plus } \frac{1}{8} \text{th the projections}$ and depth of footing equal to that at column face, determine the reinforcement required. In other words the bending moment is resisted by the section $b_e \times d_e$ where

$$b_e = b + \frac{1}{8}(B - b)$$

and $d_e = d$.

The reinforcement found is to be distributed over entire width.

In the design of sloping footings, usually the depth required from bending consideration works out to be more compared to depth required from the consideration of one way or two way shear. Hence it is advantageous to determine the depth from bending consideration and check for shear. For this, determine the depth required for balanced section for which $x_u = x_{u,lim}$. Since sufficient extension of steel is to be allowed before collapse under unexpected disaster conditions, many codes recommend steel to be used in R.C.C. structures to be restricted to 75 percent of that required for balanced section. It amounts to providing $33\frac{1}{3}$ rd percent extra

depth. Hence select depth equal to $\frac{4}{3}$ times the value found for balanced section. **In sloping footing for rectangular columns, it is better to keep the sides of the footing in the same ratio as the sides of column.**

Check for one way shear is to be made at a distance 'd' from the face of the column. The section resisting it is trapezoidal as shown in Fig. 9.27. In the literature there appears to be lot

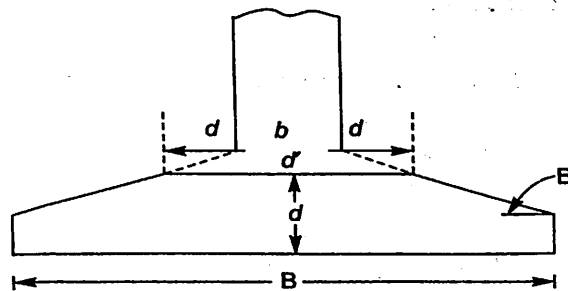

Fig. 9.27

of confusion about finding nominal shear in trapezoidal section. Some have calculated it as two way shear and compared the value with permissible one way shear. Some have tried to find maximum shear at neutral axis, but approximated in taking the area resisting it. Author suggests the following method as more appropriate:

Since the moment increases numerically in the direction as the effective depth 'd' increases, the nominal shear is given by (Clause B.5.1.1)

$$\tau_v = \frac{V_u - \frac{M \tan \beta}{d}}{bd}$$

Where M is the design bending moment at the section and β is the angle between the top and bottom edges. In sloping footings width 'b' is not constant. This may be approximated as $\frac{B+b'}{2}$. Hence resisting area is $\frac{B+b'}{2} d$ or may be taken as cross sectional area.

Example 9.4. Design a sloping footing for a short axial column of size 300 mm \times 300 mm, carrying 600 kN load. Use M20 concrete and Fe 415 steel. SBC of soil is 180 kN/m². Sketch the details of reinforcement.

Solution :

Size of Footing

$$\text{Load from column} = 600 \text{ kN}$$

$$\text{Self wt of footing} = \frac{1}{10} \times 600 = 60 \text{ kN}$$

$$\text{Total load on soil} = 660 \text{ kN}$$

$$\text{SBC of soil} = 180 \text{ kN/m}^2$$

$$\text{Area of footing required} = A = \frac{660}{180} = 3.667 \text{ m}^2$$

Provide 2 m \times 2 m footing

Design Pressure

$$q_u = 1.5 \times \frac{600}{2 \times 2} = 225 \text{ kN/m}^2 = 0.225 \text{ N/mm}^2.$$

Design of Footing By Method 1:

Bending Moment:

The critical section is at the face of the column as shown in Fig. 9.28.

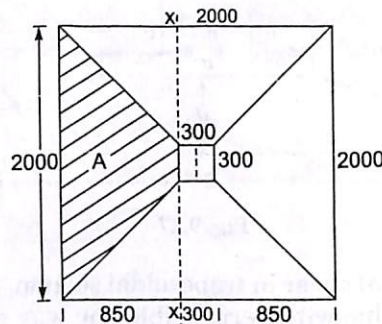

Fig. 9.28

Area of shaded portion

$$A = \frac{2000 + 300}{2} \times 850 = 977500 \text{ mm}^2$$

Upward force from soil on this portion

$$= q_u A = 0.225 \times 977500 = 219938 \text{ N}$$

Centroid of this force from the face of column is at a distance

$$\begin{aligned}
 &= \frac{2B + b}{B + b} \times \frac{l}{3} = \frac{2 \times 2000 + 300}{2000 + 300} \times \frac{850}{3} \\
 &= 529.71 \text{ mm.}
 \end{aligned}$$

Hence bending moment of this force about column face

$$\begin{aligned}
 M_u &= 219938 \times 529.71 \\
 &= 116.503 \times 10^6 \text{ N-mm}
 \end{aligned}$$

Let d be depth of balanced section required to resist this moment. Width of section to be considered is b . Since Fe 415 steel is to be used

$$\begin{aligned}
 x_{u\text{lim}} &= 0.48 d \\
 M_u &= 0.36 f_{ck} b x_{u\text{lim}} (d - 0.42 x_{u\text{lim}}) \\
 &= 0.138 f_{ck} b d^2
 \end{aligned}$$

i.e., $116.5 \times 10^6 = 0.138 \times 20 \times 300 d^2$

$\therefore d = 375.15 \text{ mm.}$

To make footing more flexible let us take

$$d = \frac{4}{3} \times 375.15 = 500 \text{ mm}$$

The depth at edges should be minimum of 150 mm. Let us keep the depth at edges as 200 mm, Fig. 9.29 shows the section selected

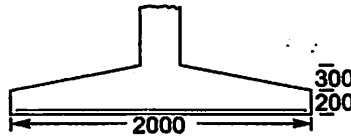

Fig. 9.29.

Checking the depth for one way shear

The critical section is at distance $d = 500 \text{ mm}$ from the face of the column as shown in Fig. 9.30.

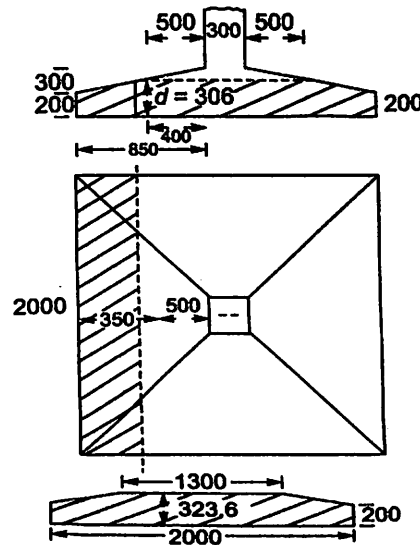

Fig. 9.30

Depth of footing at this critical section

$$= 200 + \frac{850 - 500}{850} \times (500 - 200)$$

$$d = 323.5 \text{ mm}$$

Top width of footing at this section

$$= 500 + 300 + 500 = 1300 \text{ mm}$$

$$\therefore \text{Average width } b = \frac{2000 + 1300}{2} = 1650 \text{ mm}$$

Design moment at this section is

$$M = 0.225 \times 2000 \times \left(\frac{850 - 500}{2} \right)^2 = 27562500 \text{ N-mm}$$

$$\tan \beta = \frac{500 - 200}{850} = 0.353$$

$$\tau_v = \frac{\frac{157500 - 27562500}{323.5} \times 0.353}{1650 \times 323.5}$$

$$= 0.235 \text{ N/mm}^2$$

But minimum strength of M20 concrete is 0.28 N/mm^2 (table 19 in IS 456). Hence depth provided is sufficient.

Check for Two way Shear

The critical section is at a distance $\frac{d}{2}$ from the face of column *i.e.* at 250 mm as shown in Fig. 9.31.

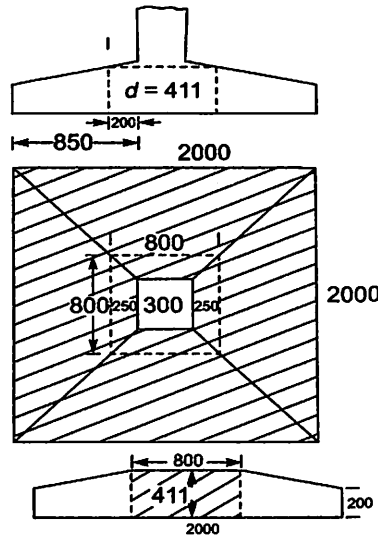

Fig. 9.31.

\therefore Side of critical section

$$= 250 + 300 + 250 = 800 \text{ mm}$$

∴ Perimeter of this section

$$= 4 \times 800 = 3200 \text{ mm}$$

$$\text{Depth at critical section} = 200 + \frac{850 - 250}{850} \times (500 - 200) = 411 \text{ mm}$$

∴ Area of concrete resisting two way shear

$$= 3200 \times 411 \text{ mm}^2$$

Two way shear force (punching shear) on the critical section

$$V_u = 0.225 (2000 \times 2000 - 800 \times 800) \\ = 756000 \text{ N.}$$

$$\therefore \text{Nominal shear} \quad \tau_v = \frac{V_u}{A} = \frac{756000}{3200 \times 411} = 0.57$$

But permitted two way shear stress = $0.25\sqrt{20} = 1.118 \text{ N/mm}^2$

Hence the section is safe in two way shear.

Reinforcement

The bending moment is resisted by an equivalent section 300 mm wide and 500 mm deep. From the expression,

$$M_u = 0.87 f_y A_{st} d \left[1 - \frac{A_{st} f_y}{bd f_{ck}} \right], \text{ we get}$$

$$116.503 \times 10^6 = 0.87 \times 415 \times A_{st} \times 500 \left[1 - \frac{A_{st}}{300 \times 500} \frac{415}{20} \right]$$

$$645.4 = A_{st} = \left[1 - \frac{A_{st}}{7228.9} \right]$$

$$\text{i.e., } A_{st}^2 - 7228.9 A_{st} + 645.4 \times 7228.9 = 0$$

$$\therefore A_{st} = 716 \text{ mm}^2$$

This is to be provided in a width of 2000 mm. Using 12 mm bars,

$$\therefore S = \frac{\frac{\pi}{4} \times 12^2}{716} \times 2000 = 315 \text{ mm}$$

Provide 12 mm bars at 300 mm c/c in both directions.

Check for Bond Length

$$L_d = \frac{0.87 f_y \phi}{4 \tau_{bd}}$$

$$\tau_{bd} = 1.2 \times 1.6 = 1.92 \text{ N/mm}^2 \text{ (clause 26.2.1.1 in IS 456)}$$

$$\therefore L_d = \frac{0.87 \times 415 \times 12}{4 \times 1.92} = 564 \text{ mm.}$$

Assuming 50 mm side cover

Length of bars beyond column face,

$$= 850 - 50 = 800 \text{ mm.}$$

= sufficient bond length is available.

The details of reinforcement is shown in Fig. 9.32.

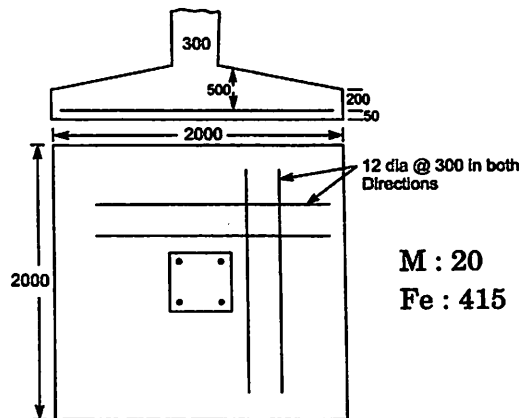

Fig. 9.32.

Design by Method 2

Bending moment about critical section at the face of the column

$$M_u = 0.225 \times 2000 \times 850 \times \frac{850}{2} = 162.56 \times 10^6 \text{ N-mm.}$$

Equivalent width of section resisting it

$$= \text{Column width} + \frac{1}{8} \times \text{projection}$$

$$= 300 + \frac{1}{8} (2000 - 300) = 512.5 \text{ mm.}$$

$$x_{u \text{ lim}} = 0.48 d$$

∴ Depth of balanced section is given by

$$162.56 \times 10^6 = 0.36 \times 20 \times 512.5 \times 0.48 d [d - 0.42 \times 0.48 d]$$

∴

$$d = 339 \text{ mm}$$

Depth to be selected

$$= \frac{4}{3} \times 339 = 452 \text{ mm}$$

Say

$$d = 460 \text{ mm}$$

Check the depth for one way and two way shear.

They will be found safe.

Reinforcement

$$M_u = 0.87 f_y A_{st} d \left[1 - \frac{A_{st} f_y}{bd f_{ck}} \right]$$

$$162.503 \times 10^6 = 0.87 \times 415 \times A_{st} \times 475 \left[1 - \frac{A_{st}}{512.5 \times 475} \times \frac{415}{20} \right]$$

$$947.5 = A_{st} \left[1 - \frac{A_{st}}{11731.9} \right]$$

$$A_{st}^2 - 11731.9 A_{st} + 947.5 \times 11731.9 = 0$$

∴

$$A_{st} = 1040 \text{ mm}^2$$

As against the requirement of 716 mm² in the previous method. Provide 12 mm bars at 210 mm c/c. Required bond length is available.

Conclusion :

If method 1 is used for the design it needs more concrete and less steel, while if method 2 is used concrete requirement is less and requirement of steel is more.

9.8.5. Design of Footing for Circular Columns

Circular columns may be provided with square footings or circular footings.

Square Footing

A typical square footing for a circular column is shown in Fig. 9.33. The cross section of footing is kept uniform if the footing size is small and is made sloping if it is large. According to clause 34.2.2 in IS 456, for the purpose of design, the face of the column shall be taken as the side of a square inscribed within the perimeter of the round column. Thus for a column of diameter d , equivalent square column has the side $d \sin 45^\circ = 0.707d$. Then the design procedure is the same as the design of footing for a square column

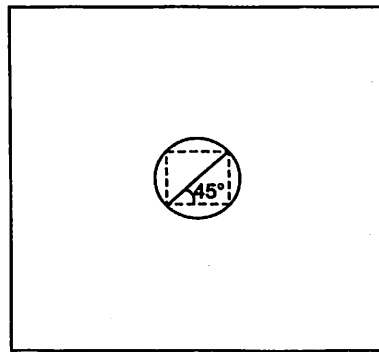

Fig. 9.33. Circular Column with square footing.

Circular Footing

Figure 9.34 shows a typical circular footing for a circular column. The soil has

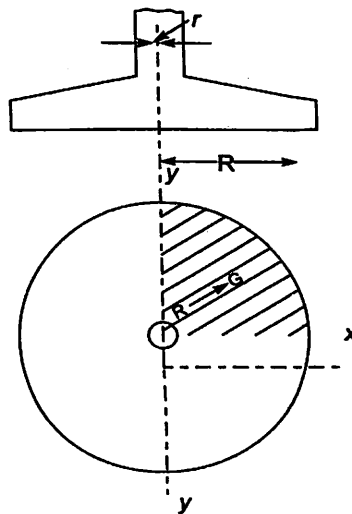

Fig. 9.34. Circular Column with circular Footing.

to resist a load of $P + \frac{1}{10}P$. Hence if SBC is known, radius of footing required is given by

$$\pi R^2 = \left(\frac{P + \frac{1}{10}P}{SBC} \right)$$

Then design upward pressure $q_u = 1.5 \frac{P}{\pi R^2}$. Depth of footing is calculated from the consideration of bending moment and checked for two way shear. For this a quadrant of circle may be taken and bending moment at the face of column may be found.

Total upward pressure in the quadrant

$$= q_u \pi (R^2 - r^2)$$

The centroid of quadrant of a circle from the two diametral x - y axis is

$$\bar{x} \text{ or } \bar{y} = \frac{4r}{3\pi}$$

\therefore Its centroid from the centre of circle

$$\bar{r} = \sqrt{\left(\frac{4r}{3\pi}\right)^2 + \left(\frac{4r}{3\pi}\right)^2} = 0.6 r \text{ for quadrant of column}$$

and

$$\bar{R} = 0.6 R \text{ for quadrant of footing.}$$

\therefore The distance of centroid of shaded area from the centre of circle

$$= \frac{\frac{\pi}{4} R^2 0.6 R - \frac{\pi}{4} r^2 \times 0.6 r}{\frac{\pi}{4} (R^2 - r^2)}$$

$$= \frac{0.6(R^3 - r^3)}{R^2 - r^2} = \frac{0.6[R^2 + Rr + r^2]}{R + r}$$

\therefore The distance of centroid of upward pressure from the face of the column

$$\bar{x} = \frac{0.6[R^2 + Rr + r^2]}{R + r} - 0.6 r$$

\therefore The moment of upward pressure about the column face

$$M_u = q_u \pi (R^2 + Rr + r^2) \bar{x}.$$

Breadth of quadrant

$$= \frac{\pi r}{2}$$

\therefore The depth required for balanced section, d is obtained by the equation

$$M_u = 0.36 f_{ck} b x_{ulim} (d - 0.42 x_{ulim})$$

To keep the required reinforcement to 75 percent of that for balanced section, increase the depth by $33\frac{1}{3}$ percent

Check for two way shear

Circular sections are checked for two way shear for which critical section is at $r_2 = r + \frac{d}{2}$.

Two way shear force

$$F_2 = q_u \pi (R^2 - r_2^2)$$

If depth at this section is d_2 , the area resisting above shear force

$$A_2 = \frac{\pi}{2} (r_2) d_2$$

$$\therefore \tau_v = \frac{F_2}{A_2}$$

This value should be less than permissible value of $k_s \times 0.25 \sqrt{f_{ck}}$ (clause B.5.2.1)

If not safe increase the depth. For the selected depth design the reinforcement. One way shear action is not predominant in circular footing. The procedure is illustrated with example below:

Example 9.5. Design a circular footing for a circular column of diameter 400 mm carrying a working load of 850 kN. Safe bearing capacity of soil is 200 kN/m². Use M20 concrete and Fe 415 steel.

Solution :

Radius of circle $r = \frac{400}{2} = 200 \text{ mm.}$

$P = 850 \text{ kN}$ $f_{ck} = 20 \text{ N/mm}^2$ $f_y = 415 \text{ N/mm}^2$
 $SBC = 200 \text{ kN/m}^2$

Size of footing

$P = 850 \text{ kN}$
 \therefore Self at $= 85 \text{ kN}$
 Total load on soil $= 850 + 85 = 935 \text{ kN.}$

$SBC = 200 \text{ kN/m}^2$

\therefore Area of footing required $= \frac{935}{200} = 4.675 \text{ m}^2.$

\therefore Radius R of the footing is obtained by $\pi R^2 = 4.675$

$\therefore R = 1.22 \text{ m.}$

Provide $R = 1.25 \text{ m.}$

The footing selected is shown in Fig. 9.35.

Upward soil pressure for limit state design

$$q_u = \frac{1.5 \times 850}{\pi 1.25^2} = 260 \text{ kN/m}^2.$$

$$= 0.260 \text{ N/mm}^2$$

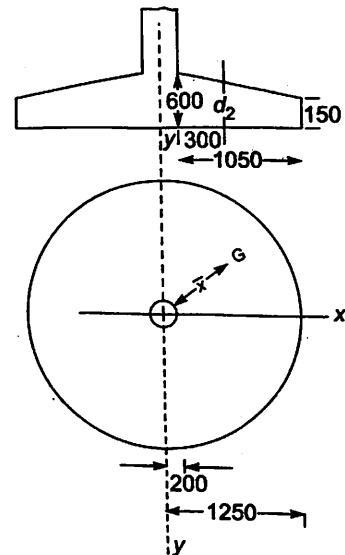

Fig. 9.35.

Total upward pressure

$$= 0.260 \times \frac{\pi}{4} [1250^2 - 200^2] = 310900 \text{ N}$$

Centroid of upward pressure on quadrant of footing from the centre of column

$$= \frac{0.6[R^2 + Rr + r^2]}{R + r}$$

$$= \frac{0.6[1250^2 + 1250 \times 200 + 200^2]}{1250 + 200}$$

$$= 767 \text{ mm.}$$

∴ Its distance from the face of the column

$$= 767 - 200 = 567 \text{ mm.}$$

∴ Moment of soil pressure about the column face

$$M_u = 310900 \times 567$$

$$= 176.28 \times 10^6 \text{ N-mm}$$

Width at column face resisting this moment

$$= \frac{\pi}{2} r = \frac{\pi}{2} \times 200 = 314.159 \text{ mm.}$$

∴ For balanced section, when Fe 415 steel is used

$$x_u = x_{u\text{lim}} = 0.48 d.$$

Equating moment of resistance to moment, we get

$$176.28 \times 28 \times 10^6 = 0.36 f_{ck} b x_{u\text{lim}} (d - 42 x_{u\text{lim}})$$

$$= 0.36 \times 20 \times 314.159 \times 0.48 d (d - 0.42 \times 0.48 d)$$

∴

$$d = 451 \text{ mm.}$$

Provide

$$d = 1.33 \times 415 \approx 600 \text{ mm.}$$

Provide 150 mm depth at free edge as shown in Fig. 9.35.

Check for Two-Way Shear:

Critical section is at a distance

$$r_2 = 200 + \frac{600}{2} = 500 \text{ mm from the centre of circular column.}$$

Depth of footing at this section $d_2 = 150 + \frac{1050 - 300}{1050} \times (600 - 150) = 471.43 \text{ mm}$

∴ Two way shear (punching) force on the critical section

$$F_2 = 0.260 \times \frac{\pi}{4} [1250^2 - 500^2]$$

$$= 1072068 \text{ N.}$$

Area of footing resisting it

$$A_2 = 2\pi r_2 d = 2\pi \times 500 \times 471.43$$

$$\therefore \tau_v = \frac{F_2}{A_2} = \frac{1072068}{2\pi \times 500 \times 471.43} = 0.724 \text{ N/mm}^2.$$

Permissible value.

$$= k_s 0.25 \sqrt{20} = 1.118 \text{ N/mm}^2$$

Since $k_s = 1$ for $d \geq 300$

Thus actual two way shear stress is less than permissible. Hence $d = 600$ mm is sufficient.

Design of Reinforcement

Let A_{st} be the reinforcement required at critical section. Then,

$$M_u = 0.87 f_y A_{st} d \left[1 - \frac{A_{st} f_y}{bd f_{ck}} \right]$$

$$176.28 \times 10^6 = 0.87 \times 415 A_{st} 600 \left[1 - \frac{A_{st}}{314.159 \times 600} \times \frac{415}{20} \right]$$

$$813.74 = A_{st} \left[1 - \frac{A_{st}}{9084.11} \right]$$

$$A_{st} = 904 \text{ mm}^2$$

Provide it in a width R in both directions. Using 12 mm bars, spacing required

$$S = \frac{\pi/4 \times 12^2}{904} \times 1250 = 156.$$

i.e., Provide 12 mm bars at 150 mm in both directions as shown in Fig. 9.36.

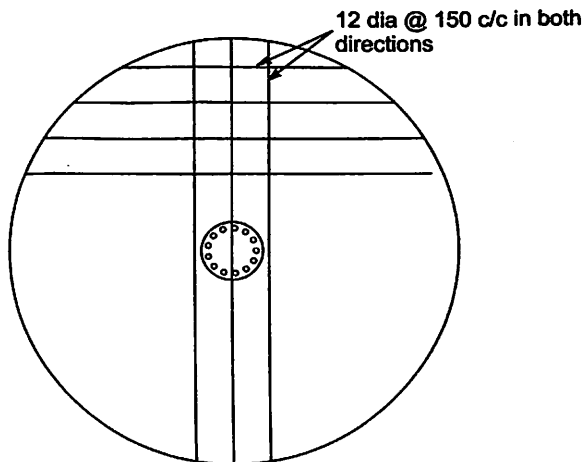

Fig. 9.36.

Check for Development Length

Development length required is given by

$$L_d = \frac{0.87 f_y \phi}{4 \tau_{bd}} = \frac{0.87 \times 415 \times 12}{4 \times 1.92}$$

$$= 564 \text{ mm.}$$

More than this length is available from the face of the column.

9.9 DESIGN OF FOOTING FOR COLUMNS CARRYING AXIAL LOAD AND MOMENT

Figure 9.37 shows a typical case. In this column is subjected to axial load P and bending moment M

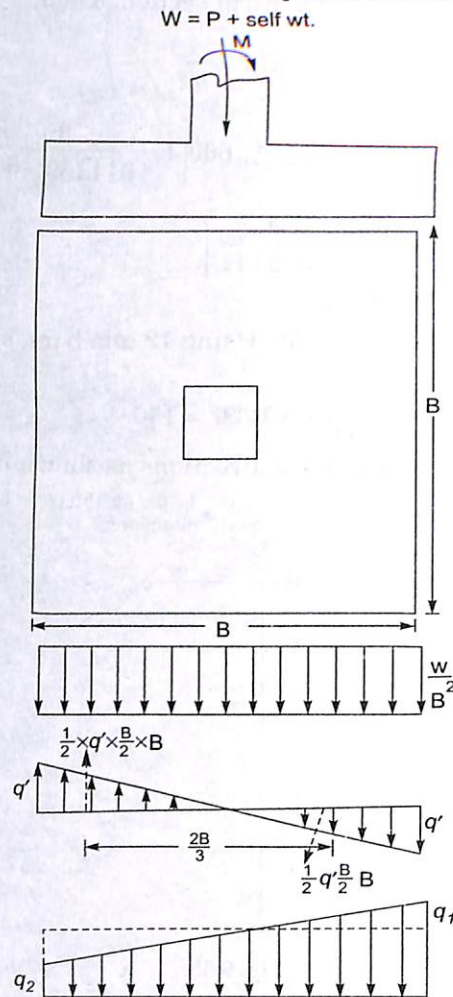

Fig. 9.37. Column Subjected to Axial Load and Bending.

The soil pressure due to axial force is uniform and is given by $P = \frac{W}{B^2}$ where W is load in column plus self weight (usually taken as 10% of P).

Due to moment one side tension is created and the other side compression is created as shown in Fig. 9.37. Let q' be the maximum pressure due to bending. Then equating moment of pressure diagram to applied moment we get,

$$\frac{1}{2} \times q' \times \frac{B}{2} \times B \times \frac{2}{3} B = M$$

$$\text{i.e.,} \quad q' = \frac{6M}{B^3}$$

\therefore Maximum soil pressure

$$q_1 = \frac{W}{B^2} + \frac{6M}{B^3}$$

and least pressure,

$$q_2 = \frac{W}{B^2} - \frac{6M}{B^3}$$

The total pressure diagram is also shown in the figure which varies linearly from q_2 to q_1 . The size of the footing should be selected so as to keep q_1 within SBC. The right hand side portion in the figure which is subjected to higher pressure is considered for design. It may be noted that for limit state design,

$$q_{u1} = 1.5 \left(\frac{P}{B^2} + \frac{6M}{B^3} \right)$$

and

$$q_{u2} = 1.5 \left(\frac{P}{B^2} - \frac{6M}{B^3} \right).$$

The critical section are same as before. The selection of depth becomes more complicated since the pressure diagram is varying. However with few trials one can arrive at required depth from the considerations of bending, one way shear and two way shear.

Alternative to above, a simple procedure is possible by providing column at a suitable eccentricity from the centroid of footing. Fig. 9.38 illustrate it. In this case, column is provide

at an eccentricity $e = \frac{M}{P}$.

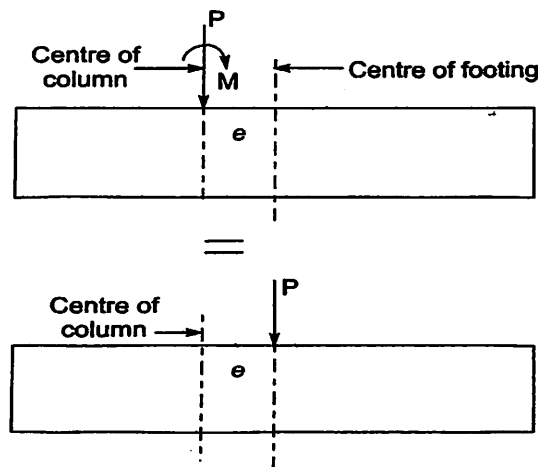

Fig. 9.38. Footing with Eccentric Column.

This is equivalent to a footing subject to an axial force P . Hence the pressure distribution is uniform. However footing projection is more on one side and less on the other side. The side with larger projection is designed and the same may be accepted throughout. This is illustrated with a problem below:

Example 9.6. Design a suitable footing for a $400 \text{ mm} \times 400 \text{ mm}$ column transferring 800 kN axial load and a moment of 32 kN-m . SBC of the soil is 200 kN/m^2 . Use M20 concrete and Fe 415 steel.

Solution :

Size of Footing

Axial Load from Column = 800 kN

Self weight of footing = 80 kN .

Total W = 880 kN .

SBC = 200 kN/m^2

\therefore Area of footing required

$$A = \frac{880}{200} = 4.4 \text{ m}^2.$$

Provide $2.1 \text{ m} \times 2.1 \text{ m}$ footing. Thus actual area of footing is $2.1 \times 2.1 = 4.41 \text{ m}^2$.

Position of Column

Moment carried by column = 32 kN-m

$$\therefore e = \frac{M}{P} = \frac{32 \times 10^6}{800 \times 10^3} = 40 \text{ mm}.$$

\therefore Position the column with 40 mm eccentricity w.r.t. the axis of footing as shown in Fig. 9.39.

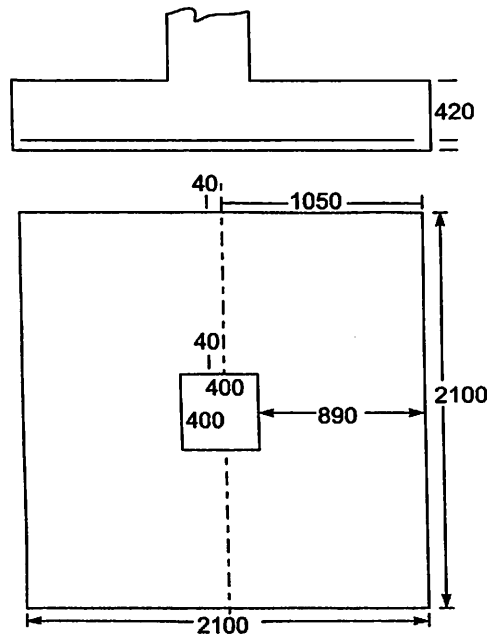

Fig. 9.39.

$$\therefore \text{Larger projection} \quad r = \frac{2100}{2} + 40 - 200 = 890 \text{ mm.}$$

Soil Pressure for Design

It is uniform since the column load and moment acting on the footing is equivalent to an axial load of 800 kN at the centre of gravity of footing.

\therefore Design pressure

$$q_u = 1.5 \times \frac{800 \times 10^3}{2100 \times 2100} = 0.272 \text{ N/mm}^2.$$

Depth of Footing

Since footing size is small, footing of uniform thickness is going to be designed. In such cases, one way shear determines the thickness. Assuming permissible shear is going to be 0.32 N/mm^2 , which corresponds 0.2% steel will be tried. The critical section is at a distance d from the face of the column. Equating resisting shear to applied shear,

we get,

$$0.32 \times B d = q_u B (1 - d)$$

$$\text{i.e.,} \quad 0.32 \times 2100 \times d = 0.272 \times 2100 (890 - d)$$

$$\therefore \quad d = 408 \text{ mm.}$$

$$\text{Provide} \quad d = 420 \text{ mm.}$$

Check for Moment

$$\therefore \quad M_{ulim} = 0.36 f_{ck} b x_{ulim} (d - 0.42 x_{ulim})$$

$$\text{For Fe 415 steel,} \quad x_{ulim} = 0.48 d$$

$$\therefore \quad M_{ulim} = 0.36 \times 20 \times 2100 \times 0.48 \times 420 (420 - 0.42 \times 0.48 \times 420) \\ = 1022.4 \times 10^6 \text{ N-mm}$$

Critical section for moment is at the face of the column. At this section

$$M_u = 0.272 \times 2100 \times 890 \times \frac{890}{2} = 226.224 \times 10^6 \text{ N-mm.}$$

Thus $M_u < M_{ulim}$.

Hence depth selected is satisfactory.

Check for Two Way Shear

The critical section is at a distance $\frac{d}{2}$ from the face of the column.

\therefore One side of critical section

$$= b + \frac{d}{2} + \frac{d}{2} = 400 + 420 = 820 \text{ mm.}$$

\therefore Perimeter $= 4 \times 820$

\therefore Area of critical section resisting two way

$$\text{Shear} = 4 \times 820 \times d = 4 \times 820 \times 420 \text{ mm}^2.$$

$$\text{Punching shear force} = 0.272 (2100 \times 2100 - 820 \times 820)$$

$$\therefore \quad \tau_v = \frac{0.272 [2100 \times 2100 - 820 \times 820]}{4 \times 820 \times 420} = 0.738 \text{ N/mm}^2$$

Permissible

$$\tau_v = k_s 0.25 \sqrt{f_{ck}} = 1 \times 0.25 \sqrt{20} = 1.118 \text{ N/mm}^2.$$

($k_s = 1$ Since $d > 300 \text{ mm}$).

Thus $\tau_v < \tau_v$ permissible.

Depth provided is satisfactory.

Reinforcement

Area of reinforcement required may be obtained from

$$M_u = 0.87 f_y A_{st} \left[1 - \frac{A_{st}}{2100 \times 420} \times \frac{415}{20} \right]$$

$$1491 = A_{st} \left[1 - \frac{A_{st}}{42506} \right]$$

$$A_{st}^2 - 42506 A_{st} + 1491 \times 42506 = 0$$

$$A_{st} = 1547 \text{ mm}^2$$

Using 12 mm bars, spacing required

$$S = \frac{\pi/4 \times 12^2}{1547} \times 2100 = 153 \text{ mm.}$$

Provide 12 mm bars at 150 mm c/c in both directions.

Check for development length:

$$L_d = \frac{0.87 f_y \phi}{4 \tau_{bd}} = \frac{0.87 \times 415 \times 12}{4 \times 1.92} = 564 \text{ mm.}$$

This much length is available from the face of the column. Hence design is satisfactory.

Reinforcement details are shown in Fig. 9.40.

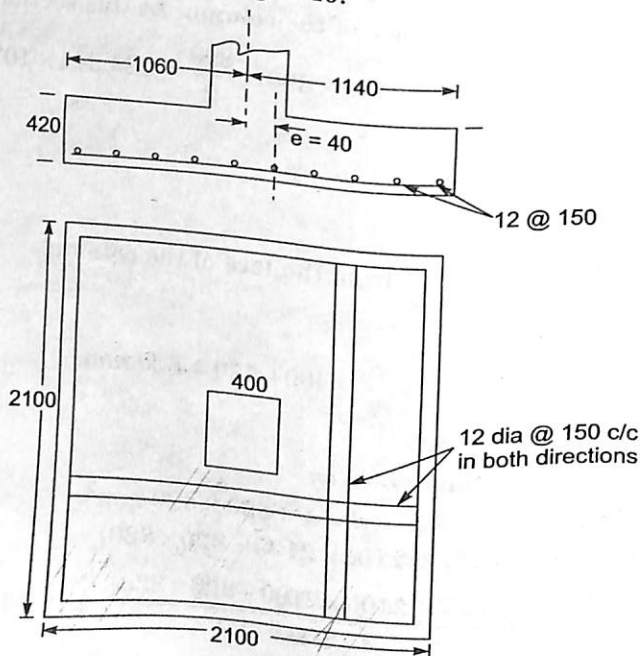

Fig. 9.40. Details of Reinforcements.

9.10. DESIGN OF PEDESTAL

A pedestal is a short compression member which has of length to width (l/D) less than 3. These are commonly used to connect steel column and R.C. footings. They help in distributing heavy bearing pressure from steel columns over a larger area before applying the load on R.C. footings. These pedestal usually project 75 to 100 mm over the floor level so that steel columns are kept from frequent wetting when floors are washed. Pedestal may have uniform cross section or may have shape of a frustum as shown in Fig 9.41. Some times

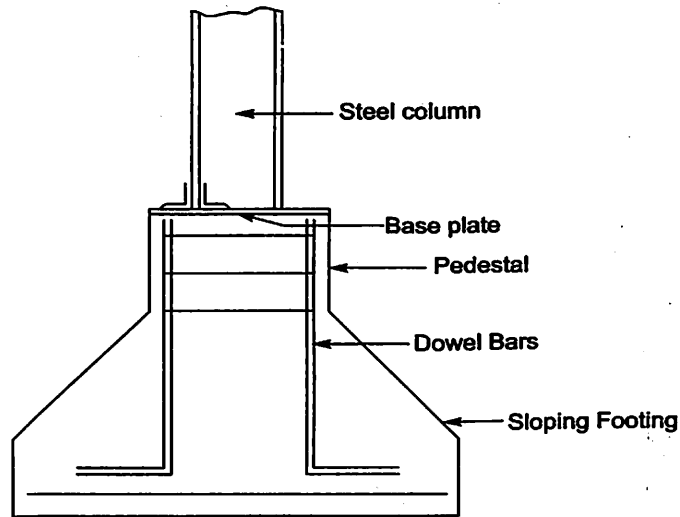

Fig. 9.41 (a) A Typical Pedestal on sloping Footing.

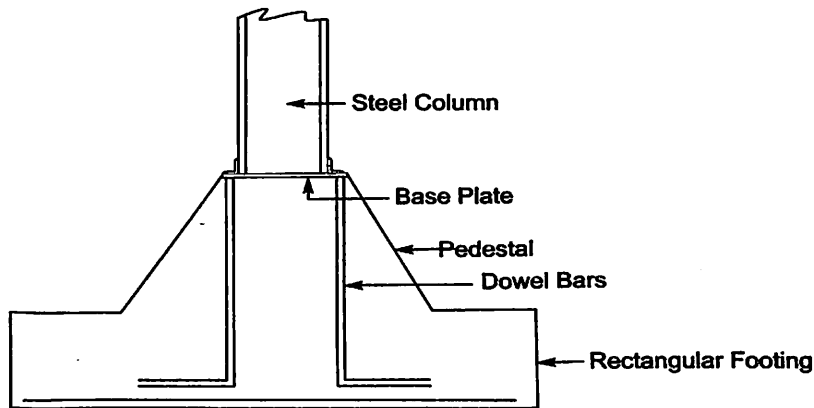

Fig. 9.41 b. Typical Pedestal of shape of frustum on Rectangular footing.

pedestals are provided to reinforced concrete columns also. In such cases, pedestal may be treated as a top step of a stepped footing.

Is 456 gives guide lines for designing the pedestals in clause 34.4.

1. Permissible stress in bearing compression $f_{br} = 0.45 f_{ck}$
2. If A_2 is the bearing area under column and A_1 is the bearing area on the footing, then

bearing stress in concrete at the top of pedestal should not be more than $f_{br} \sqrt{\frac{A_1}{A_2}}$ but not greater than $2 f_{br}$.

3. If the size of pedestal is such that the entire load is carried by concrete alone, minimum reinforcement of 0.5 percent may be provided. Minimum number of bars to be used is 4.
4. If concrete alone cannot carry all the load by bearing, dowel bars may be provided to carry balance load. If the pedestal is for concrete column the size of bars used should not exceed the diameter of the column bars by 3 mm, in no case diameter of bars used exceed 36 mm.
5. The dowel bars should have sufficient bond length which is given by

$$L_d = \frac{0.87 f_y \phi}{4 \tau_{bd}}$$

It may be noted that τ_{bd} value in compression bars is 25% more than that in tensile bars (clause 26.2.1.1). For example for Fe 415 steel and M20 concrete τ_{bd} in compression = $1.2 \times 1.6 \times 1.25 = 2.4 \text{ N/mm}^2$.

Example 9.7. Design a concrete pedestal for a steel column carrying a factored load of 1500 kN. The size of base plate is 300 mm × 300 mm. Use M20 concrete and Fe 415 steel.

Solution :

Permissible bearing stress

$$f_{br} = 0.45 f_{ck} = 0.45 \times 20 = 9 \text{ N/mm}^2.$$

Pressure on the top of the pedestal

$$= \frac{1500 \times 1000}{300 \times 300} = 16.67 \text{ N/mm}^2 < 2 \times 9 \text{ N/mm}^2.$$

Hence size of base plate selected is satisfactory.

1. Design of pedestal without dowel bars:

$$\text{Max stress permitted} = 9 \text{ N/mm}^2.$$

Area of pedestal required

$$A = \frac{1500 \times 1000}{9} = 166667 \text{ mm}^2.$$

Size of pedestal required

$$= \sqrt{A} = 408 \text{ mm.}$$

Provide 450 mm × 450 mm pedestal.

Minimum of $\frac{0.5}{100} \times 450 \times 450 = 1012.5 \text{ mm}^2$ steel is to be provided.

Provide 4 bars of 20 mm. Laterals of 8 mm at 300 mm c/c may be provided.

2. Design of Pedestal with Dowel bars

Select size of pedestal 10 mm more than steel plate i.e. 310 × 310 mm.

Load carried by concrete

$$= 9 \times 310 \times 310 = 846900 \text{ N}$$

$$\begin{aligned} \therefore \text{Load to be carried by dowel bars} \\ &= 1500 \times 1000 - 846900 \\ &= 635100 \text{ N.} \end{aligned}$$

Area of dowel bars required

$$= \frac{635100}{0.87 f_y} = \frac{635100}{0.87 \times 415} = 1759 \text{ mm}^2.$$

Minimum steel required,

$$= \frac{0.5 \times 310 \times 310}{100} = 480 \text{ mm}^2.$$

\therefore Provide 4 bars of 25 mm diameter

$$A_{sc} \text{ provided} = 4 \times \frac{\pi}{4} 25^2 = 1963 \text{ mm}^2.$$

Bond length required

$$L_d = \frac{0.87 \times f_y \phi}{4 \tau_{bd}} = \frac{0.87 \times 415 \times 25}{4 \times (1.2 \times 1.6 \times 1.25)} = 940 \text{ mm.}$$

This requirement should be taken care either by adjusting the pedestal height or by providing hooks, if required.

The reinforcement details are shown in Fig. 9.42

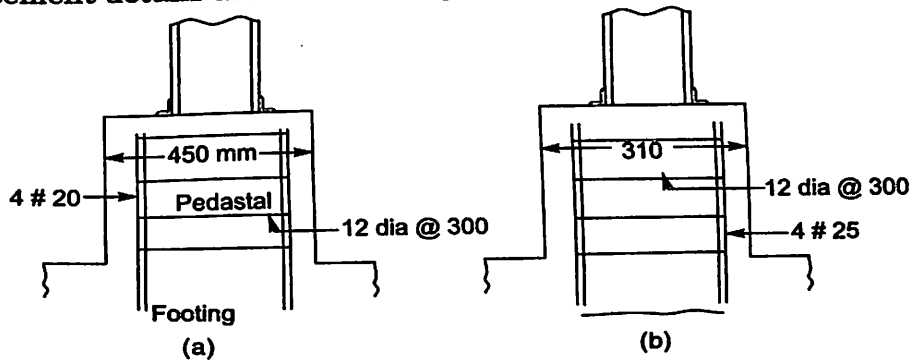

Fig. 9.42.

QUESTIONS

1. Design a footing of uniform thickness for a column of size 400 mm \times 400 mm carrying a load of 1200 kN. SBC of soil is 250 kN/m². Use M20 concrete and Fe 415 steel. Sketch the reinforcement details.
2. Design a rectangular footing for a R.C. columns 300 mm \times 450 mm carrying an axial load of 1000 kN. The safe bearing capacity of soil is 200 kN/m². Adopt M20 grade concrete and Fe 415 steel.
3. Design a sloping footing for a column of size 500 \times 500 mm carrying a load at 2000 kN. SBC of soil is 200 kN/m². Use M25 concrete and Fe 415 steel.

4. The footing of uniform thickness is to be designed for a column of size 300×450 mm carrying an axial load of 900 kN. Due to site condition one side of the footing is to be restricted to 2 m only. Design the rectangular footing using M20 concrete and Fe 415 steel.
5. Design a sloping square footing for a circular column of 500 mm diameter carrying an axial load of 1000 kN. SBC of soil is 250 kN/m^2 . Use M20 concrete and Fe 415 steel.
6. For the column given in Ex.5, design suitable circular footing.
7. Design a square footing for a column of size 500×500 mm carrying an axial load of 1000 kN and a moment of 50 kN-m. SBC of soil is 250 kN/m^2 . Use Fe 415 steel and M20 concrete.
8. A steel column is carrying a factored load of 2000 kN. The size of base plate is 350×350 mm. Use M20 concrete and Fe 415 steel. Design a pedestal
 - (i) With dowel bars
 - (ii) Without dowel bars.

Design of Stairs

10.1 INTRODUCTION

Stairs are needed for ascending and descending from floor to floor. A stair consists of a number of steps to move from one level to another. The room / space housing stairs is called stair case. To give some relaxation to public using stairs landings are provided. The stretch between two landings is called a flight. It is felt in a flight number of steps should be a maximum of 12 to 15.

Width of stairs is kept at about 900 mm in residential buildings. In public buildings it may go upto 1800 mm to 2400 mm, depending upon rush hour utilization. To allow free flow of users, the width of landing should be at least equal to width of stairs.

Each step has one tread (going) and one rise. Rise and tread are proportioned so as to provide convenient access. The accepted relation between a tread and rise are

(i) $2 \times \text{rise} + \text{tread} = 600 \text{ mm to } 640 \text{ mm.}$

(ii) $\text{rise} \times \text{tread} = 40,000 \text{ to } 42000 \text{ mm}^2.$

Usually a rise of 150 mm is convenient. For every increase of 5 mm rise tread is reduced by 10 mm. In public buildings the tread may be kept about 270 mm to 300 mm. However in commercial complex steeper stairs are used. IS code recommends that the slope of stairs should be between 25° to 40° .

10.2 DESIGN OF STAIRS

Many types of stairs are used which have different shapes and structural behaviour. Some of the commonly used stairs with different geometric shapes are shown in Fig. 10.1.

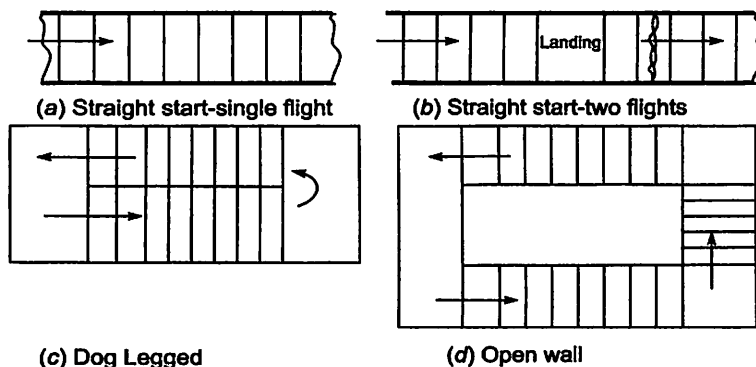

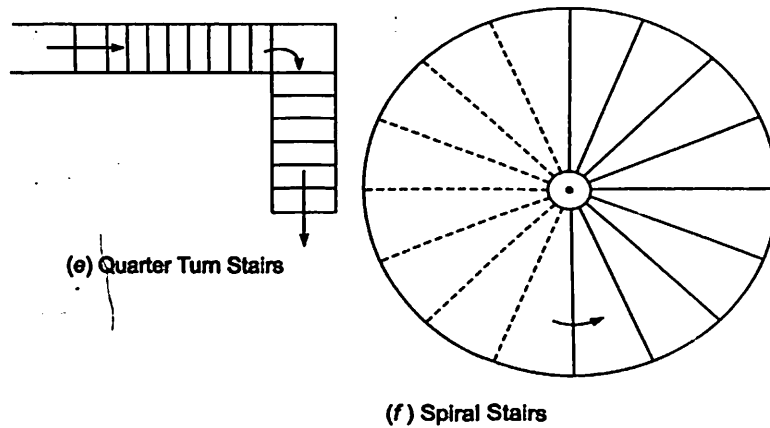

Fig. 10.1. Types of stairs.

Based on structural behaviour, the stairs can be classified into two groups

1. Stairs slab spanning horizontally
2. Stairs slab spanning longitudinally

1. Stairs Slab Spanning Horizontally

The stair slab may be supported on each side by side walls or by stinger beam on one side and wall on other side as shown in Fig 10.2. In such cases each step behaves as an independent simply supported beam spanning horizontally. Each step is considered as a rectangular beam

of width b and effective depth $\frac{D}{2}$ as shown in the figure, where $b = \sqrt{R^2 + T^2}$, R being rise and T - being tread.

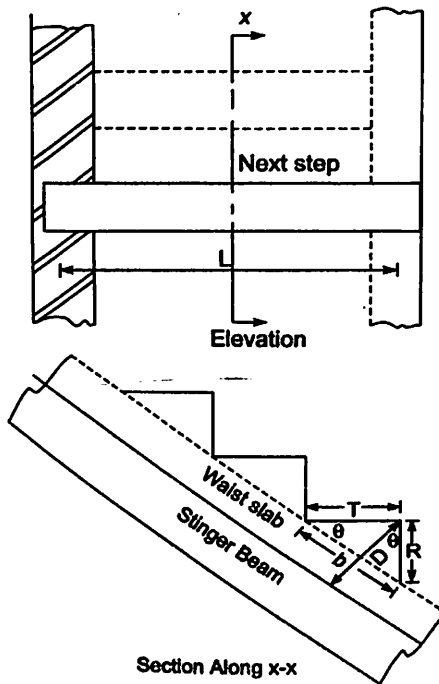

Fig. 10.2.

Some times cantilever steps are used which project from inclined beam. Steps may cantilever on only one side or may project on both sides of supporting inclined beams. In such stairs, design of step may be usually taken care by minimum sections but design of inclined beam is more important. Such stairs are shown in Fig. 10.3.

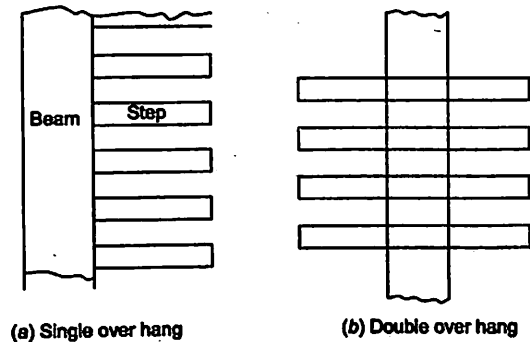

Fig. 10.3. Elevation of cantilever Steps.

2. Stair Slab Spanning Longitudinally

Dog legged, open well and quarter turn stairs come under this category of stairs. These stairs span longitudinally. Clause No. 33 in IS 456 gives guidelines to designers about depth of section, effective span and distribution of loading which are presented below:

(a) Depth of Section

The depth of section shall be taken as the minimum thickness perpendicular to the soffit of the stairs as shown in Fig. 10.4.

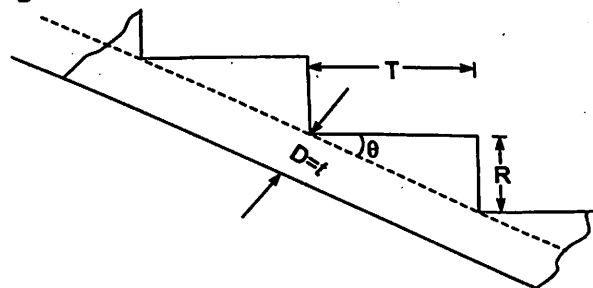

Fig. 10.4.

(b) Effective Span

The effective span of stairs without stinger beams shall be taken as the following horizontal distances.

(i) If supported at top and bottom risers by beams spanning parallel with risers. Distance centre to centre of beams (Fig. 10.5)

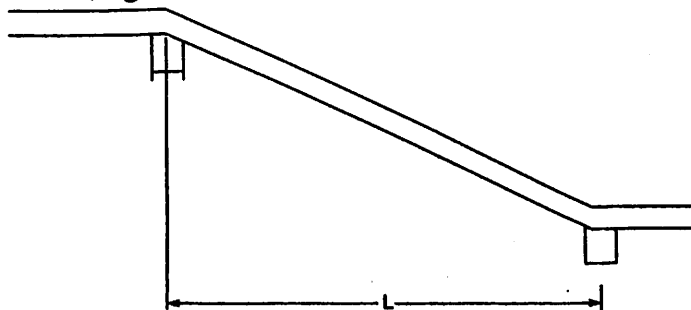

Fig. 10.5

(ii) When spanning on to the edge of a landing slab, which spans parallel with the risers (Fig. 10.6) the span of the stairs depend upon the width x and y of landing spans as shown in table below :

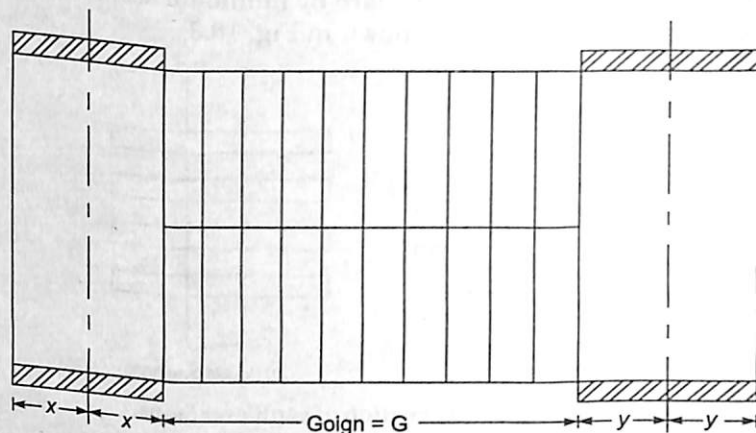

Fig. 10.6. Stairs spanning Parallel to risers.

x	y	Span in metres
<1 m	<1 m	$G + x + y$
<1 m	>1 m	$G + x + 1$
>1 m	<1 m	$G + y + 1$
>1 m	>1 m	$G + 1 + 1$.

(iii) If landing slab spans in the same direction as the stairs (Fig. 10.7), they shall be considered as acting together to form a single slab and the span determined as the distance centre to centre of the supporting beams or walls, the going being measured horizontally.

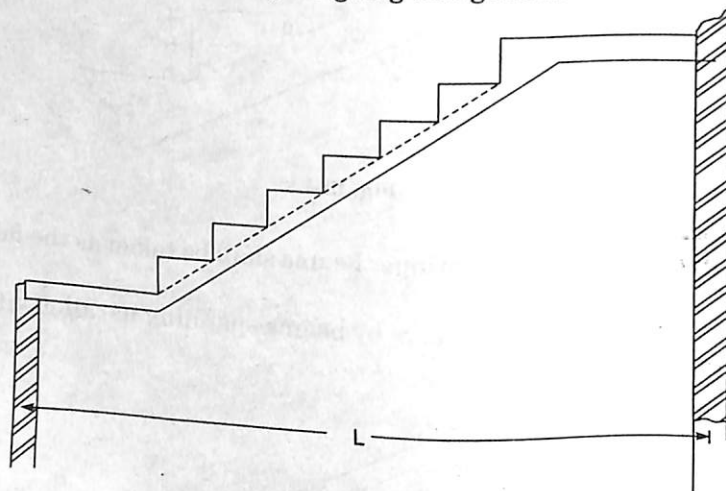

Fig. 10.7.

(c) Loads on Stairs

Live loads on stairs are prescribed in IS 875. The values prescribed are per unit horizontal area. In general, a designer may take live load on stairs as

- (i) 5 kN/m², if crowded
 (ii) 3 kN/m², if not crowded.

Dead loads are to be calculated per unit horizontal area. If T , R and t are tread, rise and waist thickness,

- (i) Weight of waist slab per unit horizontal area

$$w_1 = t \frac{\sqrt{R^2 + T^2}}{T} 25$$

$$= t \sqrt{1 + \left(\frac{R}{T}\right)^2} 25 \text{ kN/m}^2, \text{ if } t \text{ is taken in metre unit.}$$

For example, if

$$t = 80 \text{ mm}, R = 150 \text{ mm and } T = 300 \text{ mm.}$$

$$w_1 = 0.080 \sqrt{1 + \left(\frac{150}{300}\right)^2} \times 25 = 2.236 \text{ kN/m}^2$$

- (ii) Weight of steps per unit horizontal area

$$w_2 = \frac{1}{2} \times \frac{R \times T}{T} 25 = \frac{1}{2} R 25 \text{ where } R \text{ is in metre}$$

For example in the above case

$$w_2 = \frac{1}{2} \times 0.150 \times 25 = 1.875 \text{ kN/m}^2$$

Hence total dead load in the above case

$$w = w_1 + w_2 = 2.236 + 1.875 = 4.111 \text{ kN/m}^2$$

Finishing load may be added to the above value.

IS 456 gives the following clauses regarding the distribution of loads:

- (i) In case of stairs with open wells, where spans cross at right angles, the load on areas common to any two such spans may be taken as one half in each direction as shown in Fig. 10.8.

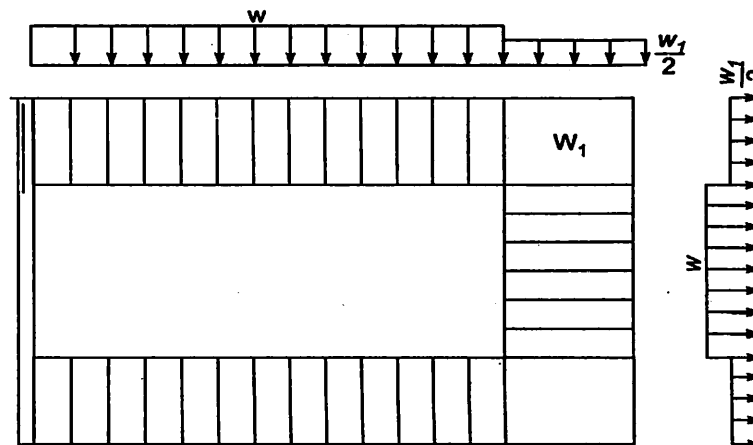

Fig. 10.8.

- (ii) When flights or landings are embedded into walls for a length of not less than 110 mm and are designed to span in the direction of the flight, a 150 mm strip may be deducted from

the loaded area and the effective breadth of the section increased by 75 mm for the purpose of design. This situation is illustrated in Fig. 10.9.

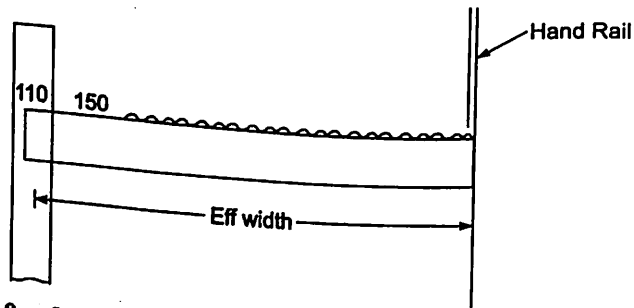

Fig. 10.9. Stairs spanning Longitudinally, built into wall on one side.

Example 10.1. A straight stair in a residential building is supported on wall at one side and by stinger beam on the other side, with a horizontal span of 1.2 metres. The risers are 150 mm and tread 300 mm. Design the steps. Use M20 concrete and Fe 415 steel. Take live load as 3kN/m^2 .

Solution :

$$R = 150 \text{ mm} \quad T = 300 \text{ mm} \quad l = 1.2 \text{ m}$$

$$f_{ck} = 20 \text{ N/mm}^2 \quad \text{and} \quad f_y = 415 \text{ N/mm}^2.$$

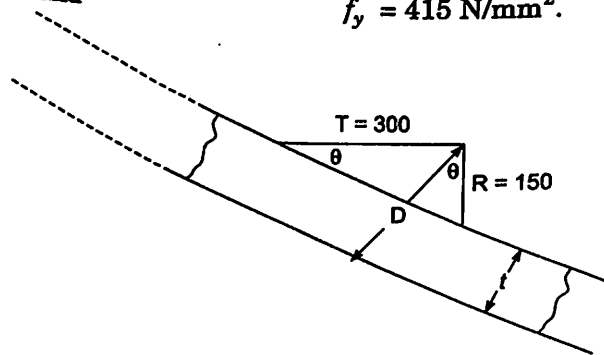

Fig. 10.10.

Referring to Fig. 10.10,

$$b = \sqrt{R^2 + T^2} = \sqrt{150^2 + 300^2} = 335.4 \text{ mm.}$$

$$D = t + R \cos \theta = t + R \frac{T}{b}$$

Taking waist slab thickness t as $\frac{1}{20}$ th span plus cover, we have

$$t = \frac{1}{20} \times 1200 + \text{cover}$$

$$= 80 \text{ mm.}$$

$$\therefore D = 80 + 150 \times \frac{300}{335} = 214 \text{ mm.}$$

$$\therefore \text{Effective depth} \quad d = \frac{D}{2} = \frac{214}{2} = 107 \text{ mm.}$$

Loads:

Loads on each step are calculated as shown below:

D.L. of waist slab per metre width of stairs

$$w_1 = 0.080 \times 0.335 \times 1 \times 25 = 0.67 \text{ kN/m}$$

D.L. of each step per metre width of stairs

$$w_2 = \frac{1}{2} \times 0.15 \times 0.30 \times 25 = 0.5625 \text{ kN}$$

Taking finishing load at a rate of 1 kN/m, its value per step = $1 \times 0.30 = 0.3 \text{ kN/m}$.

$$\begin{aligned} \therefore \text{ Total } \quad DL &= 0.67 + 0.5625 + 0.3 \\ &= 1.5325 \text{ kN/m} \end{aligned}$$

$$\text{Live load} \quad = 0.30 \times 1 \times 3 = 0.90 \text{ kN/m.}$$

$$\begin{aligned} \therefore \text{ Total load per metre width of a step} \\ &= 1.5325 + 0.90 = 2.4325 \text{ kN/m.} \end{aligned}$$

$$\therefore \quad M_u = 1.5 \times 2.4325 \times \frac{1.2^2}{8} = 0.657 \text{ kN-m.}$$

$$M_{u\text{lim}} = 0.36 f_{ck} b x_{u\text{lim}} (d - 0.42 x_{u\text{lim}})$$

$$x_{u\text{lim}} \text{ for Fe 415 steel} = 0.48 d$$

$$\begin{aligned} \therefore \quad M_{u\text{lim}} &= 0.36 f_{ck} b \times 0.48 d (d - 0.42 \times 0.48 d) \\ &= 0.138 f_{ck} b d^2 \\ &= 0.138 \times 20 \times 335 \times 107^2 \\ &= 10.59 \text{ kN-m.} > M_u \end{aligned}$$

\therefore It can be designed as singly reinforced section. Hence tensile reinforcement A_{st} is obtained by

$$M_u = 0.87 f_y A_{st} d \left[1 - \frac{A_{st} f_y}{b d f_{ck}} \right]$$

$$0.657 \times 10^6 = 0.87 \times 415 A_{st} \times 107 \left[1 - \frac{A_{st}}{335 \times 107} \times \frac{415}{20} \right]$$

$$17.00 = A_{st} \left[1 - \frac{A_{st}}{1727.5} \right]$$

$$\text{or } A_{st}^2 - 1727.5 A_{st} + 17.00 \times 1727.5 = 0$$

$$A_{st} = 17.17 \text{ mm}^2$$

But minimum steel required is

$$= \frac{0.12}{100} \times 107 \times 335 = 43.0 \text{ mm}^2$$

∴ Provide one bar of 8mm for each step. Thus

$$A_{st} \text{ provided} = \frac{\pi}{4} \times 8^2 = 50 \text{ mm}^2$$

Distribution Steel:

Distribution steel required per metre width of steps

$$= \frac{0.12}{100} \times 107 \times 1000 = 64.2 \text{ mm}^2.$$

Using 8 mm bars, spacing

$$s = \frac{\pi/4 \times 8^2}{64.2} \times 1000 = 778 \text{ mm.}$$

∴ Provide 8 mm bars at 300 mm c/c.

The details of reinforcements are shown in Fig. 10.11.

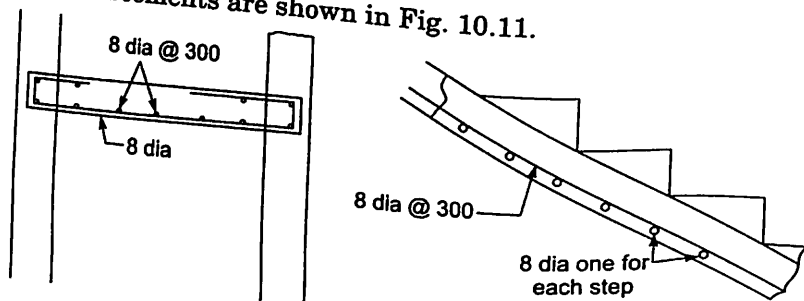

Fig. 10.11.

Example 10.2. Design a dog legged stairs for an office building in a room measuring 2.8 m × 5.8 m clear. Vertical distance between the floors is 3.6 m. Width of flight is to be 1.25m. Allow a live load of 3 kN/m². Sketch the details of the reinforcements. Use M20 concrete and Fe 415 steel. Assume the stairs are supported on 230 mm walls at the end of outer edges of landing slabs

Solution :

Let us select steps of rise 150 mm.

Floor to floor height = 3.6 m

∴ Height of one flight = $\frac{3.6}{2} = 1.8\text{m} = 1800 \text{ mm.}$

∴ Number of Risers = $\frac{1800}{150} = 12.$

Hence number of treads required = 12 - 1 = 11.

As width of stairs is 1.25 m, minimum landing width required = 1.25 m.

For 11 treads we need a length of 11 × T. Selecting tread T = 300mm, the steps may be arranged as shown in Fig. 10.12.

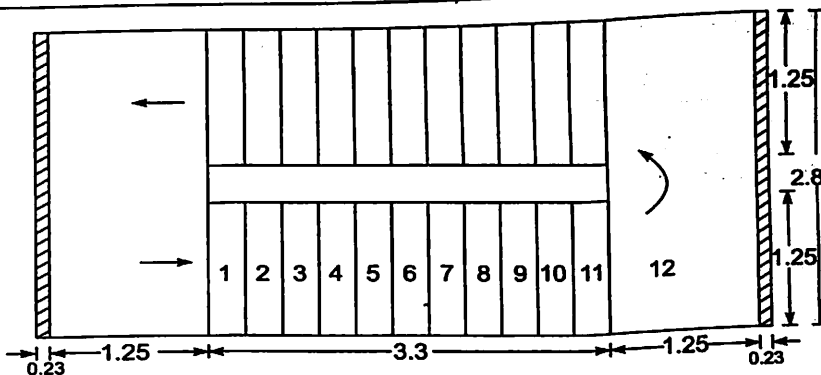

Fig. 10.12.

Effective Span:

The stairs slab span longitudinally

$$\begin{aligned} \text{Effective span} &= \text{Centre to centre distance of walls} \\ &= 1.25 + 3.3 + 1.25 + 0.23 \\ &= 6.03 \text{ m} \end{aligned}$$

Loads:

Thickness of waist slab is to be $\frac{1}{20}$ th to $\frac{1}{25}$ th span i.e., 300 to 240 mm.

Let us take $t = 250$ mm and $D = 280$ mm.

Let us find load per metre horizontal width of stairs.

$$\begin{aligned} \therefore \text{Weight of waist slab} &= 0.28 \sqrt{1 + \left(\frac{150}{300}\right)^2} \times 25 \\ &= 7.83 \text{ kN/m} \end{aligned}$$

$$\text{Weight of steps} = \frac{1}{2} \times \frac{0.15 \times 0.25}{0.25} \times 25 = 1.875 \text{ kN/m}$$

$$\therefore \text{Dead load} = 7.83 + 1.875 = 9.7 \text{ kN/m}$$

In going portion with finishing load, let us take

$$DL = 10.5 \text{ kN/m}$$

In landing portion

$$DL = 0.25 \times 1 \times 25 = 6.25 \text{ kN/m}$$

With finishing material, it may be taken as = 7.25 kN/m

$$\text{Live load} = 3 \text{ kN/m}^2$$

$$\begin{aligned} \therefore \text{Factored load on going per meter horizontal width} \\ &= 1.5 (10.5 + 3) = 20.25 \text{ kN/m} \end{aligned}$$

and on landing slab per metre width total load

$$= 1.5 (7.25 + 3) = 15.375 \text{ kN/m}$$

∴ Loading on the projected slab is as shown in Fig. 10.13.

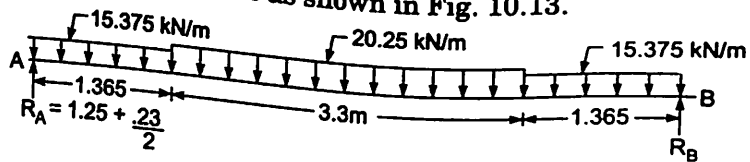

Fig. 10.13.

Design Moment:

Due to symmetry,

$$R_A = R_B = \frac{1}{2} \times \text{total load}$$

$$= \frac{1}{2} \times [15.375 \times 1.365 + 3.3 \times 20.25 + 15.375 \times 1.365]$$

$$= 54.40 \text{ kN}$$

Maximum moment occurs at mid span and its value is

$$M_u = 54.40 \times \frac{6.03}{2} - 15.375 \times 1.365 \left(\frac{6.03 - 1.365}{2} \right) - \frac{3.3}{2} \times 20.25 \times \frac{3.3}{4}$$

$$= 87.5 \text{ kN-m}$$

For Fe 415,

$$M_{u \text{ lim}} = 0.36 f_{ck} b x_{u \text{ lim}} (d - 0.42 x_{u \text{ lim}})$$

$$x_{u \text{ lim}} = 0.48d$$

$$M_{u \text{ lim}} = 0.36 f_{ck} b 0.48 d (d - 0.42 \times 0.48 d)$$

$$= 0.138 f_{ck} b d^2$$

$$= 0.138 \times 20 \times 1000 \times 250^2$$

$$= 172.5 \times 10^6 \text{ N-mm} > M_u$$

Hence the section can be designed as singly reinforced.

Reinforcement:

Let A_{st} be the area of reinforcement required.

Then,

$$M_u = 0.87 f_y A_{st} d \left[1 - \frac{A_{st} f_y}{bd f_{ck}} \right]$$

$$87.5 \times 10^6 = 0.87 \times 415 \times A_{st} \times 250 \left[1 - \frac{A_{st}}{1000 \times 250} \times \frac{415}{20} \right]$$

$$969.39 = A_{st} \left[1 - \frac{A_{st}}{12048} \right]$$

i.e., $A_{st}^2 - 12048 A_{st} + 969.39 \times 12048 = 0$

$$A_{st} = 1063 \text{ mm}^2$$

Using 16mm bars, spacing required

$$S = \frac{\pi/4 \times 16^2}{1063} \times 1000 = 189 \text{ mm}$$

∴ Provide 16mm bars at 180 mm c/c

Distribution Steel

$$A_{st} = 0.12 \text{ percent of gross sectional area}$$

$$\frac{0.12}{100} \times 1000 \times 280 = 336 \text{ mm}^2$$

Using 10mm bars. Spacing required

$$S = \frac{\pi/4 \times 10^2}{336} \times 1000 = 233 \text{ mm}$$

Provide 10mm bars at 230 mm c/c

The reinforcement is provided in the other flight also in the same manner. The details of reinforcement is shown in Fig. 10.14 [carefully note the manner in which reinforcement is to be provided at the inner edges of landing slab]

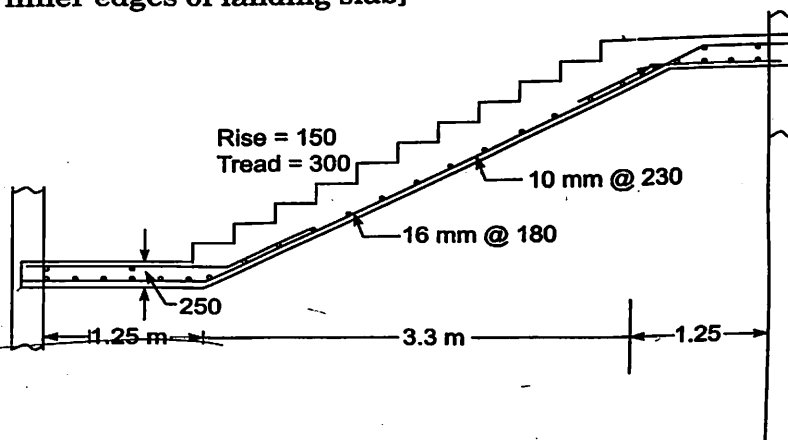

Fig. 10.14.

Example 10.3. In the example 10.2, if landing slab is supported on sides as shown in Fig. 10.15, design the dog legged stairs.

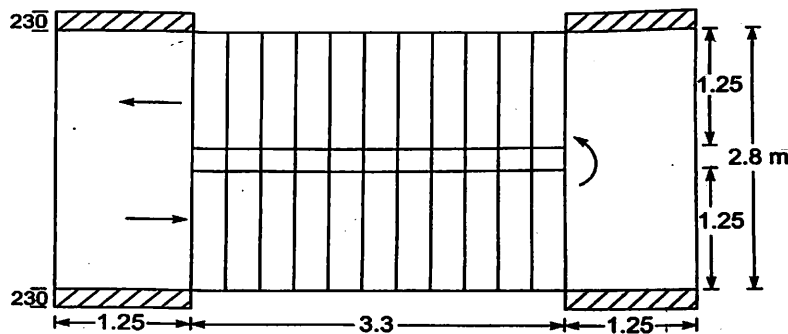

Fig. 10.15.

Solution :

In this case

$$x = \frac{125}{2} \text{ m} = 0.625 \text{ m}$$

$$y = \frac{125}{2} \text{ m} = 0.625 \text{ m}$$

$$\therefore \text{Effective span } l = 0.625 + 3.3 + 0.625 = 4.55 \text{ m}$$

Hence thickness of waist slab should be about

$$\frac{4.55 \times 1000}{20} \text{ to } \frac{4.55 \times 1000}{25}$$

Provide

$$t = 200 \text{ mm and overall depth } D = 230 \text{ mm}$$

Loads:

(i) On going:

$$\text{Weight of Waist Slab} = 0.23 \times \sqrt{1 + \left(\frac{150}{300}\right)^2} \times 25$$

$$= 6.42 \text{ kN/m}$$

$$\text{Weight of Steps} = \frac{1}{2} \frac{0.15 \times 0.30}{0.30} \times 25 = 1.875 \text{ kN/m}$$

$$DL = 6.42 + 1.875 = 8.30 \text{ kN/m}$$

With finishing let us say $DL = 9.25 \text{ kN/m}$

(ii) On landing slab:

$$\text{Weight of slab} = 0.23 \times 1 \times 25 = 5.75 \text{ kN/m}$$

$$\text{With finishing say, } DL = 6.75 \text{ kN/m}$$

$$\text{Live load} = 3 \text{ kN/m}^2$$

\therefore per metre width of stairs,

$$\text{factored load on going} = 1.5 \times (9.25 + 3.0) = 18.375 \text{ kN/m}$$

$$\text{and factored load on landing} = 1.5 (6.75 + 3.0) = 14.625 \text{ kN/m}$$

The factored load is as shown in Fig. 10.16.

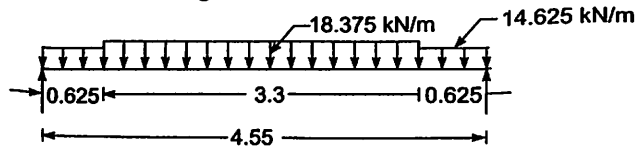

Fig. 10.16.

$$R_A = R_B = \frac{1}{2} [14.625 \times 0.625 + 18.375 \times 3.3 + 14.625 \times 0.625]$$

$$= 39.46 \text{ kN}$$

$$M_u = 39.46 \times \frac{4.55}{2} - 14.625 \times 0.625 \left(\frac{4.55 - 0.625}{2} \right) - 18.375 \frac{3.3}{2} \times \frac{3.3}{4}$$

$$= 46.82 \text{ kN-m}$$

$$\begin{aligned} M_{u \text{ lim}} &= 0.36 f_{ck} b x_{u \text{ lim}} (d - 0.42 x_{u \text{ lim}}) \\ &= 0.36 f_{ck} b 0.48 d (d - 0.42 \times 0.48 d) \\ &= 0.138 f_{ck} b d^2 \\ &= 0.138 \times 20 \times 1000 \times 200^2 \\ &= 110.4 \times 10^6 \text{ N-mm} \end{aligned}$$

$M_u < M_{u \text{ lim}}$ Hence singly reinforced section can be designed.

$$46.82 \times 10^6 = 0.87 \times 415 A_{st} 200 \left[1 - \frac{A_{st}}{1000 \times 200} \frac{415}{20} \right]$$

$$648.38 = A_{st} \left[1 - \frac{A_{st}}{9638.55} \right]$$

$$A_{st}^2 - 9638.55 A_{st} + 648.38 \times 9638.55 = 0$$

$$\therefore A_{st} = 699 \text{ mm}^2$$

Using 12mm bars, $S = \frac{\pi/4 \times 12^2}{699} \times 1000 = 161.8 \text{ mm}$

Provide 12mm bars at 150 mm c/c

Distribution steel

$$= \frac{0.12}{100} \times 1000 \times 200 = 240 \text{ mm}^2$$

Provide 8mm bars at $S = \frac{\pi/4 \times 8^2}{240} \times 1000 = 209 \text{ mm c/c}$

i.e., provide 8mm bars at 200 mm c/c

Design of Landing Slab:

It spans parallel to risers

$$l = 2.8 + \text{thickness of wall}$$

$$= 3.03 \text{ m}$$

Factored load on it = 14.625 kN/m

Moment per meter width

$$M_u = 14.625 \times \frac{3.03^2}{8} = 16.78 \text{ kN-m}$$

$$\therefore 16.78 \times 10^6 = 0.87 \times 415 A_{st} 200 \left[1 - \frac{A_{st}}{1000 \times 200} \frac{415}{20} \right]$$

$$232.43 = A_{st} \left[1 - \frac{A_{st}}{9638.6} \right]$$

$$A_{st}^2 - 9638.6 A_{st} + 232.43 \times 9638.6 = 0$$

$$A_{st} = 238 \text{ mm}^2$$

Provide 8mm bars at 200mm c/c, which fulfills the minimum requirement of 240mm^2 , steel. Fig. 10.17 shows the details of reinforcement

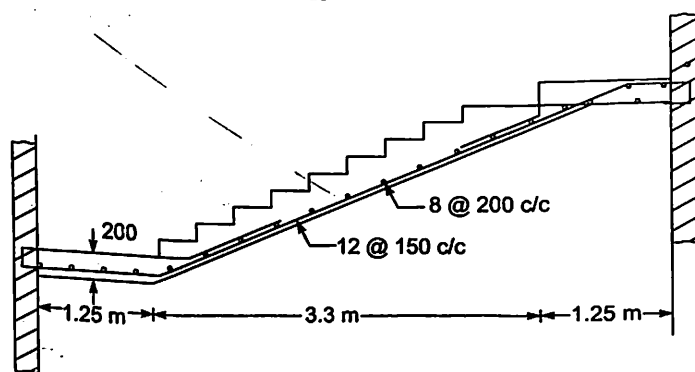

Fig. 10.17.

Example 10.4. Design an intermediate flight of dog legged stairs for the details given in Example 10.2, providing landing beams at the inner edge of landing slabs.

Solution :

In this case span reduces to 3.3m only. Hence waist slab thickness can be about 150mm only. Stairs of 3.3m with waist thickness 150mm may be designed taking

$$M_u \approx \frac{M_u \ell^2}{8}$$

The design procedure is the same as used in Examples 10.2 and 10.3

Example 10.5. Design the first flight of the dog legged stairs for the problem given in Example 10.2

Solution :

In the first flight there is no landing on one side. Hence the span is

$$l = 3.3 + 1.25 + \frac{0.23}{2} = 4.665 \text{ m}$$

This may be designed as explained in the example 10.2. Waist thickness may be reduced or kept same as in the other flights. Usually same thickness is maintained from aesthetic point, but reinforcement may be reduced. The details of its connection to ground is to be carefully noted. Fig. 10.18 shows the details

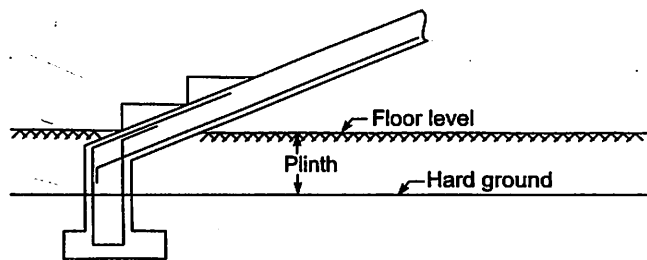

Fig. 10.18.

Example 10.6. A stair with open well is having steps of size $280\text{mm} \times 150\text{mm}$. The arrangement of stairs is as shown in Fig. 10.19. Design the stairs for a live load of 3 kN/m^2 . Use M20 concrete mix and Fe 415 steel. Sketch the details of reinforcement.

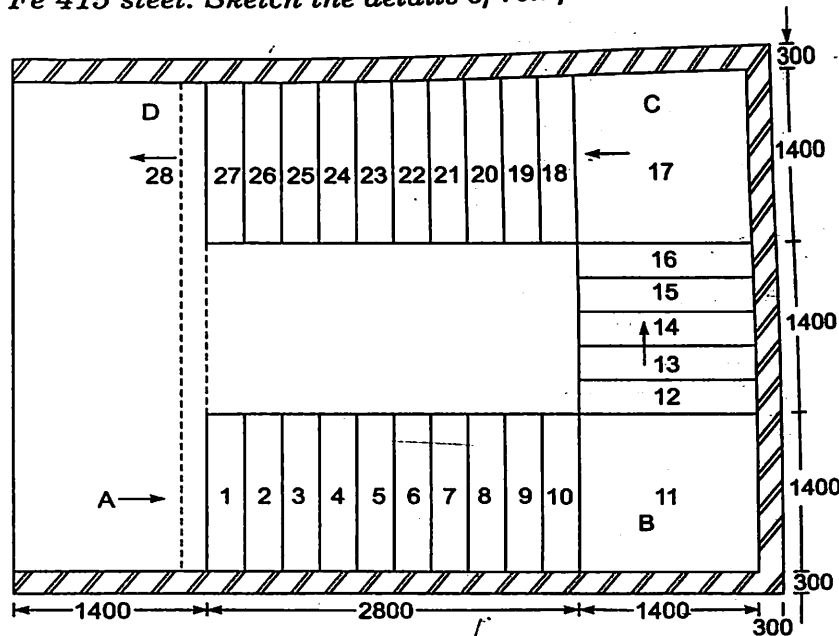

Fig. 10.19.

Solution :**Effective Span**

Flight AB and CD

$$l = 0.15 + 2.8 + 1.4 + 0.15 = 4.5\text{ m}$$

Flight BC

$$l = 0.15 + 1.4 + 1.4 + 1.4 + 0.15 = 4.5\text{ m}$$

Thus all flights have effective span = 4.5 m

Hence thickness of waist slab is to be between $\frac{1}{25} \times 4500$ to $\frac{1}{20} \times 4500$. Let us take

$$t = 200\text{ mm and } D = 230\text{ mm}$$

Loads

Consider 1 m wide stair.

Load on going:

$$\text{Weight of waist slab} = 0.23 \times 1 \times \sqrt{1 + \left(\frac{150}{280}\right)^2} \times 25 = 6.523\text{ kN/m}$$

$$\text{Weight of steps} = \frac{1}{2} \times 0.150 \times \frac{0.280}{0.280} \times 25 = 1.875\text{ kN/m}$$

∴

$$D.L. = 6.523 + 1.875 = 8.398\text{ kN/m}$$

Say with finishing $DL = 9.0\text{ kN/m}$ Live load = 3 kN/m ∴ Factored Load = $1.5(9.0 + 3) = 18\text{ kN/m}$

Load on Landing:

Weight of landing slab = $0.23 \times 1 \times 25 = 5.75 \text{ kN/m}$
 Live load = 3 kN/m
 Weight of finishing = 1 kN/m
 \therefore Total $DL = 9.75 \text{ kN/m}$
 Factored Load = $1.5 \times 9.75 = 14.625 \text{ kN/m}$

Design of Flight AB

Fig. 10.20 shows the load on this flight per meter width

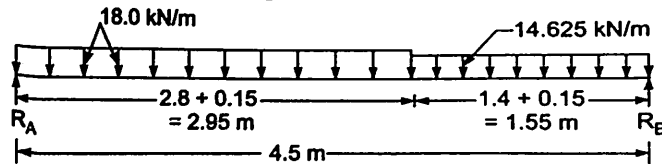

Fig. 10.20.

Taking moment about B,

$$R_A \times 4.5 = 18 \times 2.95 \left(4.5 - \frac{2.95}{2} \right) + 14.625 \times 1.55 \times \frac{1.55}{2}$$

\therefore
 $R_A = 39.6 \text{ kN}$

Shear force is zero at

$$x = \frac{39.6}{18} = 2.2 \text{ m from A}$$

\therefore Maximum moment occurs at 2.20m from A. Hence design moment,

$$M_u = 39.6 \times 2.20 - 18 \times 2.20 \frac{2.2}{2}$$

$$= 43.56 \text{ kN-m}$$

Reinforcement:

$$M_u = 0.87 f_y A_{st} d \left[1 - \frac{A_{st} f_y}{bd f_{ck}} \right]$$

$$43.56 \times 10^6 = 0.87 \times 415 A_{st} 200 \left[1 - \frac{A_{st}}{1000 \times 200} \times \frac{415}{20} \right]$$

$$603.24 = A_{st} \left[1 - \frac{A_{st}}{9638.55} \right]$$

$$A_{st}^2 - 9638.55 A_{st} + 603.24 \times 9638.55 = 0$$

$$A_{st} = 646.6 \text{ mm}^2$$

Using 12mm bars, spacing required is

$$S = \frac{\pi/4 \times 12^2}{646.6} \times 1000 = 174.9 \text{ mm}$$

∴ Provide 12 mm bars at 170 mm c/c

Distribution Steel:

$$A_{st} = \frac{0.12}{100} \times 1000 \times 200 = 240 \text{ mm}^2$$

Using 8mm bars, spacing required

$$S = \frac{\pi/4 \times 8^2}{240} \times 1000 = 209 \text{ mm}$$

Provide 8mm bars at 200 mm c/c.

Design of Flight BC:

Loading on this is as shown in Fig. 10.21.

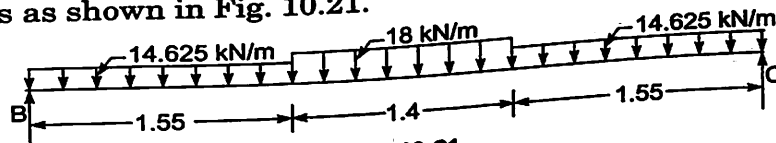

Fig. 10.21.

Due to symmetry,

$$R_B = R_C = \frac{1}{2} [14.625 \times 1.55 + 18.00 \times 1.4 + 14.625 \times 1.55] = 35.27 \text{ kN}$$

Maximum moment occurs at mid span

$$\begin{aligned} M_u &= 35.27 \times \frac{4.5}{2} - 14.625 \times 1.55 \left(\frac{4.5 - 1.55}{2} \right) - 18.00 \frac{1.4}{2} \times \frac{1.4}{4} \\ &= 41.40 \text{ kN-m} \end{aligned}$$

Reinforcement:

$$41.40 \times 10^6 = 0.87 \times 415 A_{st} \times 200 \left[1 - \frac{A_{st}}{1000 \times 200} \frac{415}{20} \right]$$

$$573.32 = A_{st} \left[1 - \frac{A_{st}}{9638.6} \right]$$

$$A_{st}^2 - 9638.6 A_{st} + 573.32 \times 9638.6 = 0$$

$$A_{st} = 612.2 \text{ mm}^2$$

Using 12mm bars, spacing required is

$$S = \frac{\pi/4 \times 12^2}{612.2} \times 1000 = 184.7 \text{ mm}$$

∴ Provide 12mm bars at 180 mm c/c

Reinforcement detail is shown in Fig 10.22.

Distribution steel is again 8mm diameter at 200 mm c/c

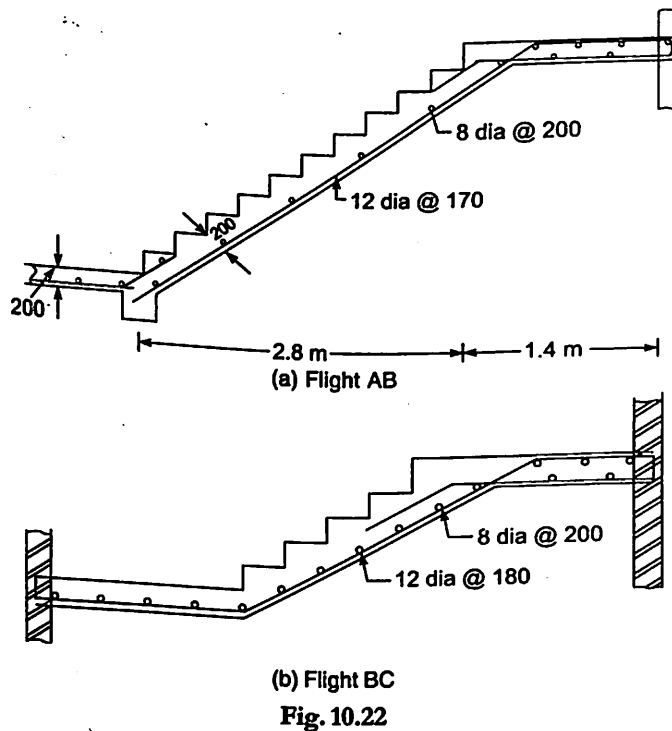

10.3 DESIGN OF TREAD-RISER TYPE STAIRS

A typical tread-riser type stairs is shown in Fig. 10.23. It is not having any waist slab. This type of stairs is popular, because of its aesthetic appearance. Its design is not much different from the design of other stairs. But there is considerable difference in the manner reinforcement is to be provided.

It is designed as a slab of effective depth ' d ' and of span ' L '. The spacing of reinforcement in landing slab and going portion may be varied. The procedure is illustrated with the example 10.7 below :

Example 10.7. Design tread-riser type stairs in flight AB shown in Fig. 10.23. Live load to be considered is 3 kN/m^2 . Use M20 grade concrete and Fe 415 steel.

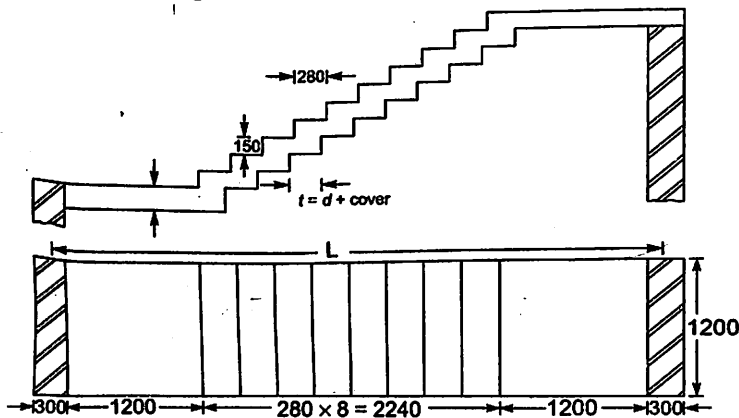

Solution :

$$\begin{aligned}
 R &= 150 \text{ mm} & T &= 280 \text{ mm} & \text{Width of landing slab} &= 1200 \text{ mm} \\
 f_{ck} &= 20 \text{ N/mm}^2 & f_y &= 415 \text{ N/mm}^2 & & \\
 \text{Thickness of walls} & & &= 300, \text{ mm} & & \\
 \text{Effective span} & & &= \frac{300}{2} + 1200 + 2240 + 1200 + \frac{300}{2} & & \\
 & & &= 4940 \text{ mm} & & \\
 \therefore \text{ Thickness of stairs} & & &= \frac{1}{25} \text{ th to } \frac{1}{20} \text{ th of span} & & \\
 & & &= 197 \text{ mm to } 247 \text{ mm} & & \\
 \text{Let} & & & d = 200 \text{ mm and } D = 230 \text{ mm} & &
 \end{aligned}$$

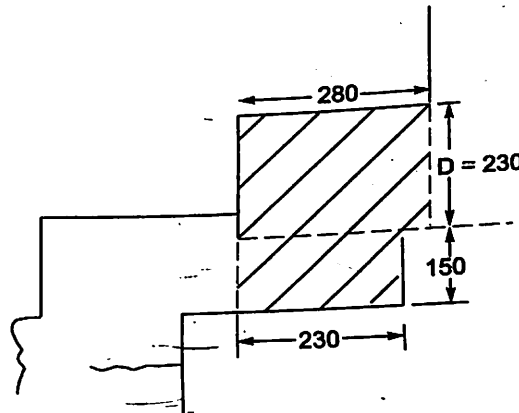
Loads per metre width of stairs**(i) on going :**

$$\begin{aligned}
 \text{Self weight of one step} &= (0.15 \times 0.23 + 0.28 \times 0.23) \times 1 \times 25 \\
 &= 2.472 \text{ kN}
 \end{aligned}$$

 \therefore Self weight per metre length

$$= \frac{2.472}{0.28} = 8.83 \text{ kN/m}$$

Say with finishes, self weight = 9.5 kN/m

Live load = 3 kN/m

\therefore Total Load = 9.5 + 3 = 12.5 kN/m

Factored load = 1.5 \times 12.5 = 18.75 kN/m

(ii) Load on Landing:

Self weight of slab = 0.23 \times 25 = 5.75 kN/m²

Weight of Finishes = 0.75 kN/m²

Live Load = 3 kN/m

Total Load = 9.5 kN/m

\therefore Factored Load = 1.5 \times 9.5 = 14.25 kN/m

Design Moment

Loading on the stairs on plan area is as shown in Fig 10.24

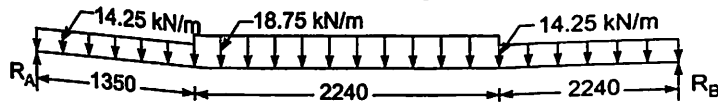

Fig. 10.24.

Due to symmetry,

$$\begin{aligned} R_A = R_B &= \frac{1}{2} \times \text{total load} \\ &= \frac{1}{2} [14.25 \times 1.35 + 18.75 \times 2.24 + 14.25 \times 1.35] \\ &= 40.24 \text{ kN} \end{aligned}$$

Maximum moment occurs at mid span

$$\begin{aligned} M_u &= 40.24 \times \frac{4.94}{2} - 14.25 \left(\frac{4.94}{2} - \frac{1.35}{2} \right) - 18.75 \times \frac{2.24}{2} \times \frac{2.24}{4} \\ &= 62.05 \times 10^6 \text{ N-mm} \\ &= 62.05 \text{ kN-m} \end{aligned}$$

Maximum moment in landing slab occurs at a distance 1.35m from the end support. Design moment for landing slab

$$\begin{aligned} &= 40.24 \times 1.35 - 14.25 \times 1.35 \times \frac{1.35}{2} \\ &= 40.94 \text{ kN} \end{aligned}$$

Reinforcement:

$$\begin{aligned} x_{u \text{ lim}} &= 0.48 d \\ M_{u \text{ lim}} &= 0.36 f_{ck} b x_{u \text{ lim}} (d - 0.42 x_{u \text{ lim}}) \\ &= 0.36 f_{ck} b \cdot 0.48 d (d - 0.42 \times 0.48 x_{u \text{ lim}}) \\ &= 0.138 f_{ck} b d^2 \\ &= 0.138 \times 20 \times 1000 \times 200^2 \\ &= 110.4 \times 10^6 \text{ N-mm} \end{aligned}$$

which is more than M_u .

Hence singly reinforced section can be designed. Equating moment to moment of resistance

$$62.05 \times 10^6 = 0.87 \times 415 \times A_{st} \times 200 \left[1 - \frac{A_{st}}{1000 \times 200} \frac{415}{20} \right]$$

$$859.3 = A_{st} \left[1 - \frac{A_{st}}{9638.6} \right]$$

$$A_{st}^2 - 9638.55 A_{st} + 859.3 \times 9638.6 = 0$$

$$A_{st} = 953.7 \text{ mm}^2$$

Using 12mm bars, spacing required is

$$S = \frac{\pi/4 \times 12^2}{953.7} \times 1000 = 118.6 \text{ mm}$$

Provide 12mm bars at 110mm c/c as shown in Fig. 10.24.

Design of landing slab:

Moment = 40.94 kN-m

$$40.94 \times 10^6 = 0.87 \times 415 A_{st} 200 \left[1 - \frac{A_{st}}{1000 \times 200} \times \frac{415}{20} \right]$$

$$557 = A_{st} \left[1 - \frac{A_{st}}{9638.55} \right]$$

$$A_{st}^2 - 9638.55 A_{st} + 585.6 \times 9638.55 = 0$$

$$A_{st} = 594 \text{ mm}^2$$

Using 12mm bars spacing required is

$$S = \frac{\pi/4 \times 12^2}{594} \times 1000 = 190.4 \text{ mm}$$

Provide 12mm bars at 190mm c/c

Distribution Steel:

$$A_{st} = \frac{0.12}{100} \times 1000 \times 230 = 276 \text{ mm}^2$$

Using 8mm bars, spacing required is

$$S = \frac{\pi/4 \times 8^2}{276} \times 1000 = 182.12 \text{ mm}$$

Provide 8mm bars in landing at 180 mm c/c and at each bend of the bars as shown in Fig. 10.25.

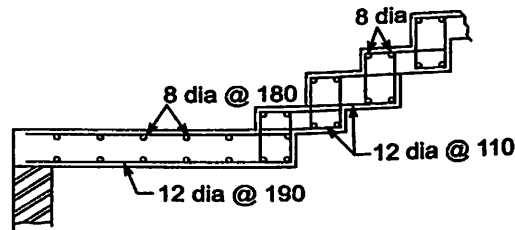

Fig. 10.25.

QUESTIONS

1. Design second flight of dog legged stairs, given the following data:

Floor to floor height = 3.6 m.

Steps of size = 150 mm rise and 280 mm tread

Imposed load = 3 kN/m²

Dimension of stair case = 2.4 m × 5.5 m.

Assume stairs are to be supported on landing beams of width 250 mm parallel to stairs. Use M20 concrete and Fe 415 steel. Sketch details of reinforcement.

2. Floor to floor vertical distance in a residential building is 3.2 m. Design a dog legged stair case, taking

Step size : 160 mm rise and 250 mm tread

Imposed load : 2.5 kN/m²

Width of stairs : 1.2 m.

Dimension of stair case : 2.4 m × 4.75 m.

Assume stairs are to be supported at the ends of landing slabs only, parallel to risers. Use M20 concrete and Fe 415 steel.

3. Design an open well type stair for a college building using the following data:

Floor to floor height = 3.6 m

No. of flights per floor = 3

Size of steps = 150 mm rise and 300 mm tread.

Landings are supported all around by walls and by beams of width 300 mm at floor levels. Thickness of wall = 300 mm.

Use M20 concrete and Fe 415 steel.

APPENDIX A

ENVIRONMENTAL EXPOSURE CONDITIONS (Clause 8.2.2.1 and 35.3.2, table 3 of IS 456-2000)

<i>Sl. No.</i>	<i>Environment</i>	<i>Exposure Conditions</i>
1.	Mild	Concrete surfaces protected against weather or aggressive conditions, except those situated in coastal area
2.	Moderate	Concrete surfaces sheltered from severe rain or freezing whilst wet. Concrete exposed to condensation and rain concrete continuously under water Concrete in contact or buried under non aggressive soil/ground water. Concrete surfaces sheltered from saturated salt air in coastal area
3.	Severe	Concrete surfaces exposed to severe rain, alternate wetting and drying or occasional freezing whilst wet or severe condensation. Concrete completely immersed in sea water. Concrete exposed to coastal environment.
4.	Very severe	Concrete surfaces exposed to sea water spray, corrosive fumes or severe freezing conditions whilst wet. Concrete in contact with or buried under aggressive sub soil/ground water
5.	Extreme	Surface of members in tidal zone. Members in direct contact with liquid/solid aggressive chemicals

APPENDIX B WORKING STRESS METHOD

B-1 INTRODUCTION

A brief introduction to this method has been given in Chapter I (Art 1.8). The concept of this method is explained here and few problems are solved.

B-2 PERMISSIBLE STRESSES

The main design criteria in the design is to keep the stresses in steel and concrete, due to working load, within the permissible values. The permissible stress in concrete is defined as ultimate stress divided by a factor of safety. In concrete a factor of safety upto 3 is used for compressive stress in bending and upto 4 for direct compressive stress. In case of mild steel permissible stress is defined as yield stress divided by factor of safety. In case of high yield strength deformed bars (Fe 415 & Fe 500), where yield point is not clearly visible, 0.2 percent proof stress is taken as yield stress. For steel, factor of safety of 1.75 to 1.85 is used. The permissible stresses specified in IS Code for concrete and steel are shown in tables B-1 to B-3.

Table B.1 Permissible Compression and Bond Stresses in Concrete in N/mm^2 Units

Grade of Concrete	Permissible Stress in Compression		Permissible Stress in Bond (Average) for Plain Bars in Tension
	Bending	Direct	
(1)	(2)	(3)	(4)
M 10	σ_{chc}	σ_{cc}	τ_{hd}
M 15	3.0	2.5	-
M 20	5.0	4.0	0.6
M 25	7.0	5.0	0.8
M 30	8.5	6.0	0.9
M 35	10.0	8.0	1.0
M 40	11.5	9.0	1.1
M 45	13.0	10.0	1.2
M 50	14.5	11.0	1.3
	16.0	12.0	1.4

Notes:

- (1) The values of permissible shear stress in concrete are given in Table B.2
 (2) The bond stress given in col 4 shall be increased by 25 percent for bars in compression.

Table B.2 Permissible Shear Stress in Concrete

$100 \frac{A_s}{bd}$	Permissible Shear Stress in Concrete, τ_c , N/mm^2					
	Grade of Concrete					
(1)	M 15	M 20	M 25	M 30	M 35	M 40 and above
	(2)	(3)	(4)	(5)	(6)	(7)
≤ 0.15						0.20
0.25	0.18	0.18	0.19	0.20	0.20	0.20
0.50	0.22	0.22	0.23	0.23	0.23	0.23
0.75	0.29	0.30	0.31	0.31	0.31	0.32
1.00	0.34	0.35	0.36	0.37	0.37	0.38
1.25	0.37	0.39	0.40	0.41	0.42	0.42
1.50	0.40	0.42	0.44	0.45	0.45	0.46
1.75	0.42	0.45	0.46	0.48	0.49	0.49
2.00	0.44	0.47	0.49	0.50	0.52	0.52
2.25	0.44	0.49	0.51	0.53	0.54	0.55
2.50	0.44	0.51	0.53	0.55	0.56	0.57
2.75	0.44	0.51	0.55	0.57	0.58	0.60
3.00 and above	0.44	0.51	0.56	0.58	0.60	0.62
	0.44	0.51	0.57	0.60	0.62	0.63

Note: A_s is that area of longitudinal tension reinforcement which continues at least one effective depth beyond the section being considered except at supports where the full area of tension reinforcement may be used provided the detailing conforms to 26.2.2 and 26.2.3

Table B.3 Permissible Stresses in Steel Reinforcement

Sl. No.	Type of Stress in Steel Reinforcement	Permissible Stresses in N/mm^2		
		Mild Steel Bars Conforming to Grade 1 of Fe 250 IS 432 (Part I)	Medium Tensile Steel Conforming to IS 432 (Part I)	High Yield Strength Deformed Bars Conforming to IS 1786 (Grade Fe 415)
(1)	(2)	(3)	(4)	(5)
(i)	Tension (σ_{st} or σ_{sv}) (a) Up to and including 20 mm (b) Over 20mm	140	Half the guaranteed yield stress subject to a maximum of 190	230
		130		230
(ii)	Compression in column bars (σ_{sc})	130	130	190
(iii)	Compression in bars in a beam or slab when the compressive resistance of the concrete is taken into account	The calculated compressive stress in the surrounding concrete multiplied by 1.5 times the modular ratio or σ_{sc} whichever is lower		
(iv)	Compression in bars in a beam or slab where the compressive resistance of the concrete is not taken into account (a) Up to and including 20mm (b) Over 20mm	140	Half the guaranteed yield stress subject to a maximum of 190	190
		130		190

Notes:

- (1) For high yield strength deformed bars of Grade Fe 500 the permissible stress in direct tension and flexural tension shall be $0.55f_y$. The permissible stresses for shear and compression reinforcement shall be as for Grade Fe 415.
- (2) For welded wire fabric conforming to IS 1566, the permissible value in tension σ_{st} is 230 N/mm^2 .
- (3) For the purpose of this standard, the yield stress of steel for which there is no clearly defined yield point should be taken to be 0.2 percent proof stress.
- (4) When mild steel conforming to Grade II of IS 432 (Part I) is used, the permissible stresses shall be 90 percent of the permissible stresses in col 3, or if the design details have already been worked out on the basis of mild steel conforming to Grade I of IS 432 (Part I); the area of reinforcement shall be increased by 10 percent of that required for Grade I Steel.

B-3 ELASTIC THEORY OF RC SECTIONS

It is based on linear elastic theory that is, within working condition stresses are proportional to strain. It assumes the bond between concrete and steel is perfect (no slipping takes place). Hence if ϵ is the strain at any point,

$$\begin{aligned} \text{Stress in concrete} &= \sigma_c = E_c \epsilon \\ \text{And stress in steel} &= \sigma_{st} = E_{st} \epsilon \\ \therefore \frac{\sigma_{st}}{\sigma_c} &= \frac{E_{st}}{E_c} \end{aligned}$$

i.e. $\sigma_{st} = \frac{E_{st}}{E_c} \sigma_c = m \sigma_c$, where m is the modular ratio B-1

The modular ratio may be assumed as

$$m = \frac{280}{3\sigma_{cbc}} \quad \text{B-2}$$

where σ_{cbc} is permissible compressive stress in concrete. If A_{st} is the area of steel and σ_{st} is the stress in it, the force resisted by steel

$$\begin{aligned} &= A_{st} \sigma_{st} \\ &= A_{st} m \sigma_c \\ &= (A_{st} m) \sigma_c \end{aligned}$$

Hence a composite area of steel and concrete may be looked as a transformed area of concrete in which area of steel is replaced by area of concrete equal to $m A_{st}$. However it may be noted that this transformation should not alter the centroid.

B-4 MOMENT OF RESISTANCE OF SECTION

Consider a rectangular section of width 'b' and effective depth 'd' as shown in Fig. B2.1. (a).

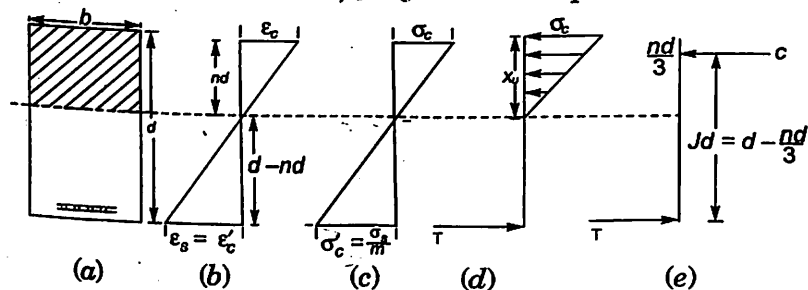

Fig. B.1.

Let the neutral axis be at a depth 'nd' from maximum compression flange. Since it is assumed that plane section remains plane, the strain diagram across the depth is linear as shown in Fig. B.1(b) in which,

$$\begin{aligned} \epsilon_c &= \text{Strain at extreme compression end and} \\ \epsilon_s &= \text{Strain in Steel} \end{aligned}$$

ϵ'_c = Strain in concrete around steel

Since perfect bond exists between steel and concrete at working load, $\epsilon_s = \epsilon'_c$ B-3

Fig. B.1(c) shows the variation of stress across the depth. If σ'_c is the stress in concrete at the level of steel and σ_s is the stress in steel, from the condition

$\epsilon_s = \epsilon'_c$, we get

$$\frac{\sigma_s}{E_s} = \frac{\sigma'_c}{E_c}$$

or
$$\sigma'_c = \frac{E_c}{E_s} \sigma_s = \frac{1}{m} \sigma_s \quad \text{B-4}$$

In working stress method, the tensile stress resisted by concrete is neglected. Hence tensile force in horizontal direction across the section is only due to stress in steel.

$$T = \sigma_s Ast \quad \text{B-5}$$

The compressive force is due to linearly varying stress in concrete as shown in Fig B.1(d). Hence the horizontal compressive force across the section is given by

$$\begin{aligned} C &= \text{Average compressive stress} \times \text{Area of beam in compression} \\ &= \frac{1}{2} \sigma'_c \times b nd \quad \text{B-6} \end{aligned}$$

If we consider the equilibrium of horizontal forces across the section, we get

$$C = T$$

Moment of resistance of the section is due to the couple moment of C & T , which is equal to

$$\begin{aligned} M &= C \text{ or } T \times \text{distance between them} \\ &= C \left(d - \frac{nd}{3} \right) \text{ or } T \left(d - \frac{nd}{3} \right) \\ &= C jd \text{ or } T jd \quad \text{B-7} \end{aligned}$$

where $jd = d - \frac{nd}{3}$ or $j = 1 - \frac{n}{3}$ B-8

B-5 BALANCED, UNDER REINFORCED AND OVER REINFORCED SINGLY REINFORCED RECTANGULAR SECTIONS:

From the expression for moment of resistance it is clear that moment of resistance depends upon the neutral axis coefficient n . If the value of n is such that the extreme compressive stress in concrete and stress in steel reach their permissible values simultaneously, then the section is said to be balanced section. Thus in balanced section

$$\sigma_c = \sigma_{cbc}$$

and

$$\sigma_s = \sigma_{st}$$

where σ_{cbc} - is permissible stress in concrete

and σ_{st} - is permissible stress in steel.

Hence from Fig. B1 - (c), we find

$$\frac{\sigma_c}{\frac{\sigma_s}{m}} = \frac{nd}{d - nd} = \frac{n}{1 - n}$$

$$\therefore \frac{\sigma_{cbc}}{\sigma_c + \frac{\sigma_{st}}{m}} = \frac{n}{1}$$

or

$$n = \frac{1}{1 + \frac{1}{m} \frac{\sigma_{st}}{\sigma_{cbc}}}$$

Now,

$$\frac{1}{m} \frac{\sigma_{st}}{\sigma_{cbc}} = \frac{1}{280} \times \frac{\sigma_{st}}{\sigma_{cbc}} = \frac{3\sigma_{st}}{280}$$

Noting this neutral axis as n_c , we have

$$\therefore n_c = \frac{1}{1 + \frac{3\sigma_{st}}{280}}$$

B-9

\(\therefore\) Critical neutral axis coefficient n

(i) for mild steel, $n_c = \frac{1}{1 + \frac{3 \times 140}{280}} = 0.4$

B-10(a)

(ii) for Fe 415, $n_c = \frac{1}{1 + 3 \times \frac{230}{280}} = 0.289$

B-10(b)

(iii) for Fe 500, $n_c = \frac{1}{1 + 3 \times \frac{275}{280}} = 0.253$

B-10(c)

Since $\sigma_{st} = 140 \text{ N/mm}^2$ for mild steel, 230 N/mm^2 for Fe 415 steel and 275 N/mm^2 for Fe 500. It may be noted that for balance section neutral axis coefficient n_c do not depend upon the grade of concrete. Moment of resistance may be calculated using $\sigma_c = \sigma_{cbc}$ or $\sigma_s = \sigma_{st}$. Thus

$$M = C j d$$

$$= \frac{1}{2} \sigma_c b n_c d \left(1 - \frac{n_c}{3}\right) d$$

$$= \frac{1}{2} \sigma_c n_c \left(1 - \frac{n_c}{3}\right) b d^2$$

B-11

For Fe 250,

$$M = \frac{1}{2} \sigma_c 0.4 \left(1 - \frac{0.4}{3}\right) b d^2$$

$$= 0.173 \sigma_c b d^2$$

For Fe 415,

B-11(a)

$$M = \frac{1}{2} \sigma_c 0.289 \left(1 - \frac{0.289}{3}\right) b d^2$$

$$= 0.130\sigma_c bd^2 \quad \text{B-11 (b)}$$

For Fe 500,

$$M = \frac{1}{2} \times \sigma_c \times 0.253 \left(1 - \frac{0.253}{3} \right) bd^2$$

$$= 0.116\sigma_c bd^2 \quad \text{B-11 (c)}$$

The moment of resistance of balance section may be found by the relation.

$$M = Tjd = \sigma_{st} Ast jd \quad \text{B-12}$$

Percentage of Steel for Balanced Section

If p_t is the percentage of steel for balanced section, then

$$p_t = 100 \frac{Ast}{bd} \text{ or } Ast = \frac{p_t}{100} bd$$

From the equilibrium condition

$$T = C, \text{ we get,}$$

$$\sigma_{st} Ast = \frac{1}{2} \sigma_{cbc} b(nd)$$

i.e.,
$$\sigma_{st} \frac{p_t}{100} bd = \frac{1}{2} \sigma_{cbc} b(nd)$$

or
$$p_t = 50n \frac{\sigma_{cbc}}{\sigma_{st}} \quad \text{B-13}$$

Under Reinforced Section

If reinforcement provided in a concrete beam is less than that required for balanced section, then neutral axis moves above the critical section ($n < n_c$), stress in steel reaches its maximum permissible value before the maximum compressive stress in concrete reaches its permissible value. This situation is shown in Fig. B-2 (a). The actual neutral axis 'n' may be located by equating moment of compression area about neutral axis to moment of equivalent tensile area about the same axis. Thus, it can be obtained by the expression,

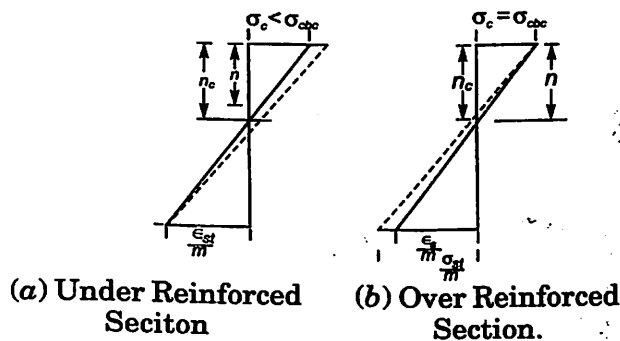

Fig. B-2.

$$b(nd) \left(\frac{nd}{2} \right) = mAst(d - nd)$$

As tensile strength reaches permissible stress, moment of resistance can be obtained from

$$M = Tjd$$

$$= \sigma_{st} Ast \left(1 - \frac{n}{3} \right) d$$

Over Reinforced Section

If the reinforcement provided is more than that required for balanced section, then neutral axis moves below the position of critical neutral axis ($n > n_c$) and results into compression stress reaching its permissible value before tensile stress in steel reaching its permissible value. This situation is shown in Fig. B2(b). The actual neutral axis may be found from equation B(13). The moment of resistance of the section is governed by stress in concrete and hence,

$$M = Cjd = \frac{1}{2} \sigma_{cbc} b nd jd$$

$$= \frac{1}{2} \sigma_{cbc} n \left(1 - \frac{n}{3} \right) bd^2$$

Example B1. A beam of size 230×450 mm is to be designed as a balanced section, using M20 concrete and Fe 415 steel. Determine the area of steel required and the moment of resistance of the balanced section. Use working stress method. Provide effective cover of 40 mm.

Solution :

- Overall depth = 450 mm
- Effective cover = 40 mm

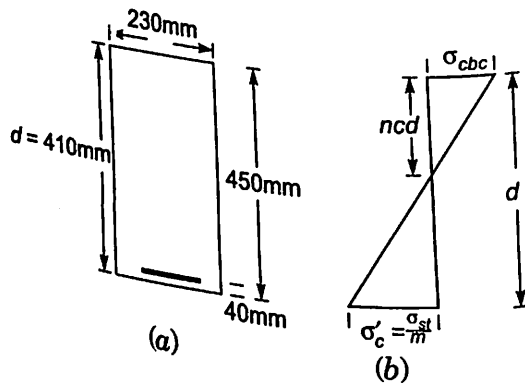

Fig. B-3.

∴ Effective depth = 410 mm
 Thus the effective size of the beam is 230×410 mm. As it is balanced section compression stress in concrete $\sigma_c = \sigma_{cbc}$ and tensile stress in steel $\sigma_s = \sigma_{st}$
 For M20 concrete $\sigma_{cbc} = 7 \text{ N/mm}^2$, and
 For Fe 415 steel $\sigma_{st} = 230 \text{ N/mm}^2$.
 From Fig. B-3(b), we get,

$$\frac{\sigma_{cbc}}{\frac{\sigma_{st}}{m}} = \frac{n_c d}{d - n_c d}$$

$$n = n_c = \frac{1}{1 + 3 \frac{\sigma_{st}}{280}} = 0.289$$

Equating tensile force to compressive force we get,

$$\sigma_{st} A_{st} = \frac{1}{2} \sigma_{cbc} b n d$$

$$230 A_{st} = \frac{1}{2} \times 7 \times 230 \times 0.289 \times 410$$

$$A_{st} = 414.7 \text{ mm}^2 \quad \text{Ans.}$$

$$M = C j d$$

$$= \frac{1}{2} \sigma_{cbc} b n d \left(d - \frac{nd}{3} \right)$$

$$= \frac{1}{2} \sigma_{cbc} \times n \left(1 - \frac{n}{3} \right) b d^2$$

$$= \frac{1}{2} \times 7 \times 0.289 \left(1 - \frac{0.289}{3} \right) \times 230 \times 410^2$$

$$= 35.34 \times 10^6 \text{ N-mm}$$

$$M = 35.34 \text{ kN-m} \quad \text{Ans.}$$

Example B2. A R.C. Section of size $230 \times 600 \text{ mm}$ is provided with 3 bars of 16 mm diameter with effective cover of 40 mm. What super imposed uniformly distributed load the beam can carry over a simply supported span of 5 m? The materials to be used are, M25 concrete and Fe 415 steel. Use working stress method.

Solution :

$$\text{Overall depth} = 600 \text{ mm}$$

$$\text{Effective cover} = 40 \text{ mm}$$

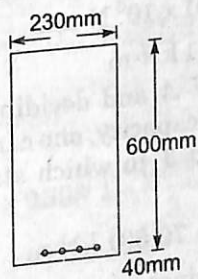

Fig. B-4.

$$\therefore \text{Effective depth} = 560 \text{ mm}$$

$$\therefore \text{Effective size is } 230 \times 560 \text{ mm.}$$

$$\text{In this case} \quad \sigma_{cbc} = 8.5 \text{ N/mm}^2, \quad \sigma_{st} = 230 \text{ N/mm}^2.$$

Let the depth of actual N-A be = nd
Area of steel provided

$$A_{st} = 3 \times \frac{\pi}{4} 16^2 \\ = 603 \text{ mm}^2$$

Equating moment of compression area and moment of transformed tensile area about the N-A, we get

$$b(nd) \left(\frac{nd}{2} \right) = m A_{st} (d - nd)$$

$$230 \frac{n^2}{2} \times 560^2 = \frac{280}{3 \times 8.5} \times 603 (1 - n) 560$$

$$n^2 = 0.1028(1 - n)$$

$$\text{i.e., } n^2 + 0.1028n - 0.1028 = 0$$

$$\text{or } n = \frac{-0.1028 + \sqrt{0.1028^2 + 4 \times 0.1028}}{2} = 0.2733$$

Critical neutral axis when Fe 415 steel is used

$$n_c = \frac{1}{1 + \frac{3\sigma_{st}}{280}} = 0.289$$

$\therefore n < n_c$ i.e., it is under reinforced section.

\therefore Moment of resistance is governed by the strength in steel

$$M = T jd$$

$$= \sigma_{st} A_{st} \left(d - \frac{nd}{3} \right)$$

$$= 230 \times 603 \left(1 - \frac{0.2733}{3} \right) \times 560$$

$$= 70.591 \times 10^6 \text{ N-mm}$$

$$= 70.591 \text{ kN-m}$$

Instead of checking with critical N-A and deciding whether stress in steel or stress in concrete governs the moment carrying capacity, one can find moment carrying capacity taking it as lower of the two values of C and T in which stresses for concrete are taken as their permissible stresses. Thus,

Now,
and

$$M = T jd = 70.591 \text{ kN-m}$$

$$M = C jd \text{ gives}$$

$$= \frac{1}{2} \times \sigma_{cbc} b (nd) \left(d - \frac{nd}{3} \right)$$

$$= \frac{1}{2} \sigma_{cbc} n \left(1 - \frac{n}{3} \right) b d^2$$

$$\begin{aligned}
 &= \frac{1}{2} \times 8.5 \times 0.2733 \left(1 - \frac{0.2733}{3} \right) \times 230 \times 560^2 \\
 &= 223.96 \times 10^6 \text{ N-mm} \\
 &= 223.96 \text{ kN-m}
 \end{aligned}$$

∴ Moment of resistance of the section

$$M = 70.591 \text{ kN-m Ans.}$$

If w is the total udl per metre run, then $\frac{wl^2}{8} = 70.591$

i.e., $w \times \frac{5^2}{8} = 70.591$ or $w = 22.586 \text{ kN/m}$

$$\text{Self wt.} = 0.23 \times 0.6 \times 25 = 3.45 \text{ kN/m}$$

∴ superimposed $udl = 22.5860 - 3.45 = 19.136 \text{ kN/m Ans.}$

Example B3. If in the beam given in example B2 is reinforced with 4 bars of 16mm instead of 3 of 16mm, determine the moment of resistance of the section. All other parameters remain the same.

Solution :

$$A_{st} = 4 \times \frac{\pi}{4} 16^2 = 804 \text{ mm}^2$$

Equating moment of compression area and transformed tensile area about the N-A, we get

$$b(nd) \left(\frac{nd}{2} \right) = m A_{st} (d - nd)$$

$$230 \frac{n^2}{2} \times 560^2 = \frac{280}{3 \times 8.5} \times 804 (1 - n) 560$$

i.e., $n^2 = 0.13708(1 - n)$

or $n^2 = 0.13708n - 0.13708 = 0$

or $n + \frac{-0.13708 + \sqrt{(13708)^2 + 4 \times 0.13708}}{2} = 0.308$

If we assume compressive stress governs the moment carrying capacity, then

$$\begin{aligned}
 M &= C jd = \frac{1}{2} \times \sigma_{cbc} b (nd) jd \\
 &= \frac{1}{2} \sigma_{cbc} nj bd^2 \\
 &= \frac{1}{2} \times 8.5 \times 0.308 \left(1 - \frac{0.308}{3} \right) 230 \times 560^2 \\
 &= 84.722 \times 10^6 \text{ N-mm} \\
 &= 84.722 \text{ kN-m}
 \end{aligned}$$

If we assume, tensile stress in steel governs the moment carrying capacity, then

$$M = T jd = \sigma_{st} A_{st} \left(1 - \frac{n}{3} \right) d$$

23836

$$\begin{aligned}
 &= 230 \times 804 \left(1 - \frac{0.308}{3}\right) 560 \\
 &= 92.924 \times 10^6 \text{ N-mm} \\
 &= 92.924 \text{ kN-m}
 \end{aligned}$$

∴ Moment of resistance of the section
 = 84.722 kN-m

If w kN is the total udl per metre run then

$$\frac{wl^2}{8} = 84.722$$

$$w \times \frac{5^2}{8} = 84.722$$

or $w = 22.111 \text{ kN/m}$

Self $wt. = 0.23 \times 0.6 \times 25 = 3.45 \text{ kN/m}$

∴ superimposed $udl = 27.111 - 3.45 = 23.661 \text{ kN/m}$ Ans.

B-6 DOUBLY REINFORCED SECTIONS AND FLANGED SECTIONS

The concept used for singly reinforced sections may be extended to doubly reinforced sections also. The additional point to be remembered in the analysis of such sections is the stress developed in compression steel is modular ratio times the strain in concrete at its level. The analysis of flanged sections also can be carried out without any difficulty. This is the method of past, author is not going into detailed analysis of these sections.

B-7 DESIGN OF R.C. SECTIONS FOR SHEAR

In a structure bending moment is most of the time associated with shear force. We know, the shear force in beams and slabs is maximum near the supports. The R.C. Section should resist this shear force safely. The design of sections for shear is as given below:

1. Find nominal shear stress (τ_v) on gross area using the expression

$$\tau_v = \frac{V}{bd}$$

where V = shear force due to design loads.

b = breadth of section. For flanged section it is breadth of web

d = effective depth.

2. Determine the permissible shear stress τ_c from the table B2
3. (a) If $\tau_v < \tau_c$, provide nominal reinforcement
 (b) If $\tau_v > \tau_{c \text{ max}}$ given in Table B-4, redesign by increasing the section,

Table B-4 Maximum shear stress $\tau_{c \text{ max}}$, N/mm²

Concrete Grade	M 20	M 25	M 30	M 35	M 40 and above
$\tau_{c \text{ max}}$	1.8	1.9	2.2	2.3	2.5

(c) If $\tau_c < \tau_v < \tau_{c \max}$, provide shear reinforcement in any of the following forms:

- (i) Vertical stirrups
- (ii) Bent up bars along with stirrups
- (iii) Inclined stirrups

In case (ii) vertical bars shall be designed to carry at least 50 percent of total shear.

Shear reinforcements shall be provided to carry a shear equal to $V - \tau_c bd$. The strength of shear reinforcement shall be calculated as below [B-5 -4, IS 456-2000]:

(i) For vertical stirrups

$$V_s = \frac{\sigma_{sv} A_{sv} d}{s_v}$$

(ii) For inclined stirrups or a series of bars bent up at different cross sections

$$V_s = \frac{\sigma_{sv} A_{sv} d}{s_v} (\sin \alpha + \cos \alpha)$$

(iii) For bent up bars

$$V_s = \sigma_{sv} A_{sv} \sin \alpha$$

Where, A_{sv} = Cross sectional area of stirrup legs

s_v = Spacing of stirrups

σ_{sv} = permissible tensile stress in shear reinforcement, subject to a maximum of 230 N/mm²

α = Angle made by bent up bar with the axis of the beam.

Example B4. The effective cross section of a R.C. beam is 250 mm × 500 mm and is reinforced with 3 bars of 16 mm diameter. The section is subjected to a shear force of 100 kN. Design the vertical stirrups. Grade of concrete used is M20 and grade of steel is Fe 415.

Solution :

$$\tau_v = \frac{100 \times 1000}{250 \times 500} = 0.8 \text{ N/mm}^2$$

percentage of steel,

$$p_t = 100 \frac{A_{st}}{bd} = \frac{100 \times 3 \times \frac{\pi}{4} \times 16^2}{250 \times 500} = 0.483$$

∴ From table B-2, (Table 23 of IS 456-2000),

$$\tau_c = 0.294 \text{ N/mm}^2 \text{ [After linear interpolation]}$$

$$\tau_{c \max} \text{ (from table B-4)} = 1.8 \text{ N/mm}^2$$

$$\therefore \tau_c < \tau_v < \tau_{c \max}$$

Hence shear reinforcements are to be provided to carry $V_{s1} = V - \tau_c bd$

$$= 1,00,000 - 0.284 \times 250 \times 500$$

$$= 63250 \text{ N}$$

$$\sigma_{sv} = 230 \text{ N/mm}^2 \text{ for Fe 415}$$

Using 8mm 2 legged stirrups,

$$A_{sv} = 2 \times \frac{\pi}{4} \times 8^2 = 100.53 \text{ mm}^2$$

256 - Design of R.C.C. Structural Elements

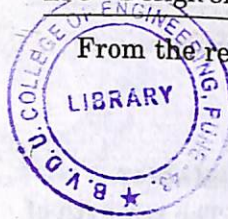

From the relation,

$$V_s = \frac{\sigma_{sv} A_{sv} d}{s_v}, \text{ we get}$$

$$63250 = \frac{230 \times 100.53 \times 500}{s_v}$$

or

$$s_v = 182.8 \text{ mm}$$

∴ Provide 2 legged 8mm stirrups at 180 mm c/c

Example B5. If in the above problem, if one bar of 16mm diameter is bent up at the section at angle 45° design the shear reinforcement.

Solution :

Shear resisted by the bent up bar

$$V_{s1} = \sigma_{sv} A_{sv} \sin \alpha$$

$$= 230 \times \frac{\pi}{4} \times 16^2 \times \sin 45$$

$$= 32700 \text{ N} > 50\% \text{ of } V_s$$

∴ Vertical stirrups will be designed for a minimum of 50% of V_s i.e.

$$V_{s2} = 0.50 \times 63250 = 31625$$

Using 2 legged 8mm Fe 415 stirrups, we get,

$$31625 = \frac{230 \times 2 \times \frac{\pi}{4} \times 8^2 \times 500}{s_v}$$

or $s_v = 365 \text{ mm}$. But maximum spacing permitted 300 mm. Hence provide 2 legged 8 mm Fe 415 st

DESIGN OF R.C.C. STRUCTURAL ELEMENTS

(R.C.C. Volume-I)

Indian standard code of practice IS-456 for the design of plain and reinforced concrete was revised in the year 2000 to incorporate durability criteria in the design. As a result of it many codal provisions have been changed. Hence there is need to train engineering students in designing reinforced cement concrete structures as per the latest code of IS -456. With his experience of more than 40 years in teaching, the author has tried to bring out students and teachers friendly book on the design of R.C.C. structures as per IS - 456 : 2000.

R.C.C. design is a vast subject. It is normally taught in two to three courses for civil engineering students. This book is for the first course in R.C.C. Design and author is writing another book 'Advance R.C.C. Design' to meet the requirement of further courses. This book deals with design philosophy and design of various structural components of building. The design procedure is clearly explained and illustrated with several examples by presenting the solutions step by step in details and with neat sketches showing reinforcement details.

Dr. S.S. Bhavikatti studied at BVB College of Engineering and Technology, Hubli for his BE (Civil) degree and graduated from Karnataka University, Dharwad in 1963, sharing first rank with another candidate. The same year he joined Karnataka Regional Engineering College, Surathkal (presently National Institute of Technology, Karnataka, Surathkal) as faculty member. He secured his ME degree in structural engineering in 1967 from University of Roorkee (presently IIT, Roorkee) under Technical Teachers Training Programme and Ph.D. degree in 1977 from IIT, Delhi under Quality Improvement Programme. He served NITK, Surathkal in various capacities like Head of Civil Engineering Department; Chairman, Central Computer Centre; Chairman, Centre for Continuing Education and Dean (Administration). In November 2001, he joined SDM College of Engineering and Technology, Dharwad as Head, Civil Engineering Department. Presently he is Vice Principal and Dean (Administration). He has published more than 50 technical papers in national and international journals and conferences. He has already published 12 books. He was member of organizing/scientific committees of international seminars of International Association of Shells and Spatial Structures (IASS) held at Taeque (South Korea) in 1990, Tokyo (Japan) in 1993 and Taipei (Taiwan) in 1997. He is member of several Indian and international professional bodies. He is chairman of Indian Concrete Institute, Karnataka, Hubli, Dharwad Centre.

ISBN 81-224-1693-4



PUBLISHING FOR ONE WORLD

NEW AGE INTERNATIONAL (P) LIMITED, PUBLISHERS

New Delhi • Bangalore • Chennai • Cochin • Guwahati • Hyderabad
Jalandhar • Kolkata • Lucknow • Mumbai • Ranchi

Visit us at www.newagepublishers.com