

LINE BISECTING

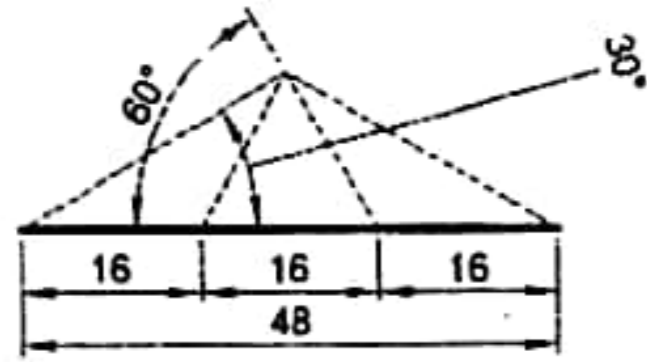

LINE TRISECTING

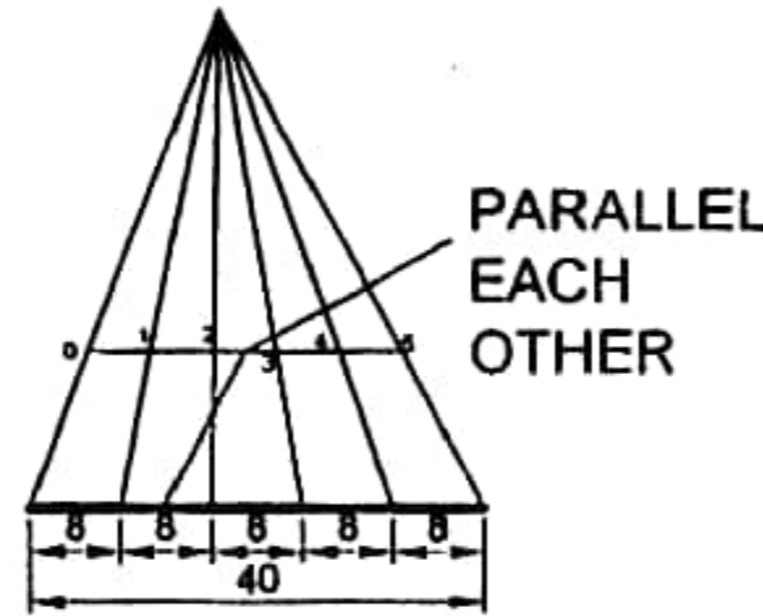
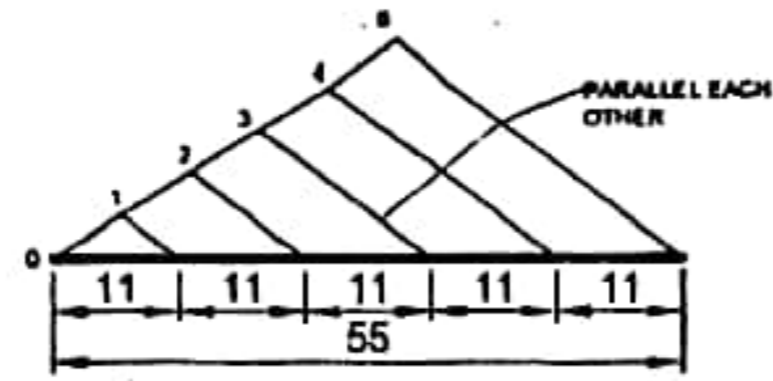

PARALLEL EACH OTHER

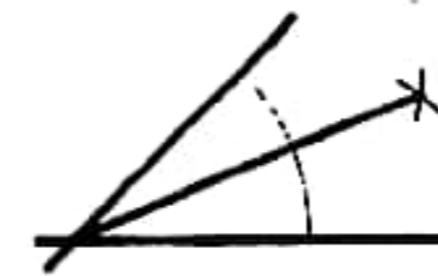

ANGLE DIVISION IN TWO EQUAL PARTS

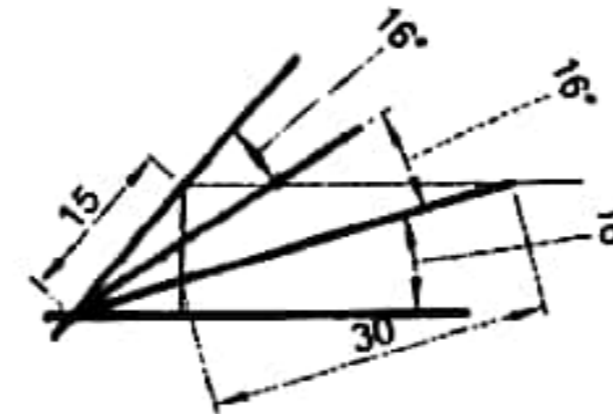

ANGLE DIVISION IN THREE EQUAL DIVISIONS

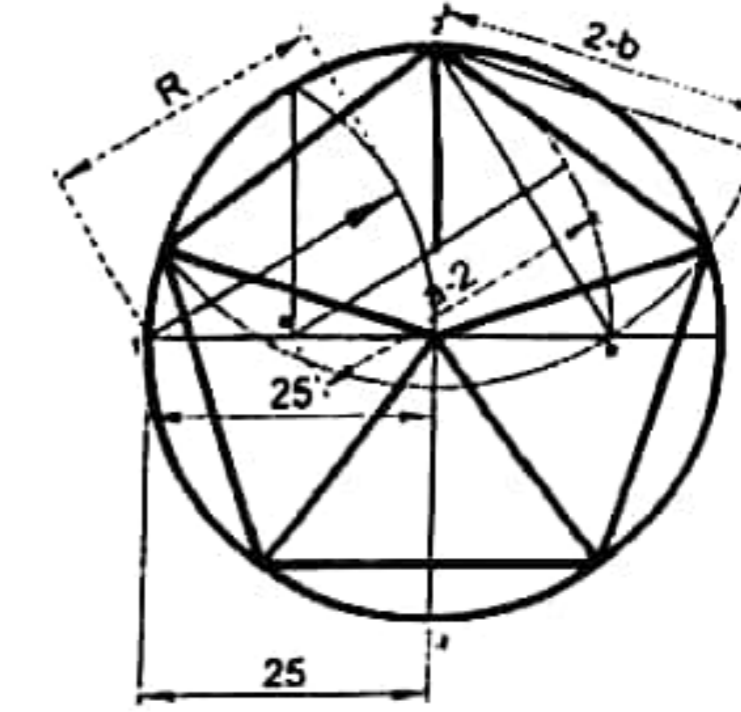

LINE DIVISION IN TWO AND THREE PARTS.

LINE DIVISION IN ANY NUMBER OF PARTS(HERE FIVE DIVISIONS)

ANGLE BI-SECTION AND TRI-SECTION

A CIRCLE DIVISION IN FIVE EQUAL DIVISION(SECTOR)

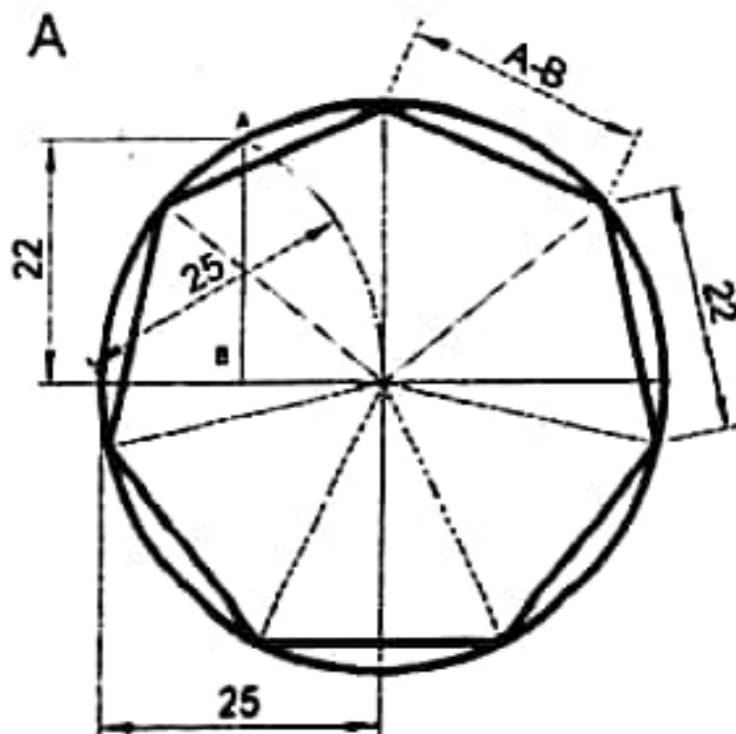

Measuring AB and marking according the length of AB along the circumference of circle.

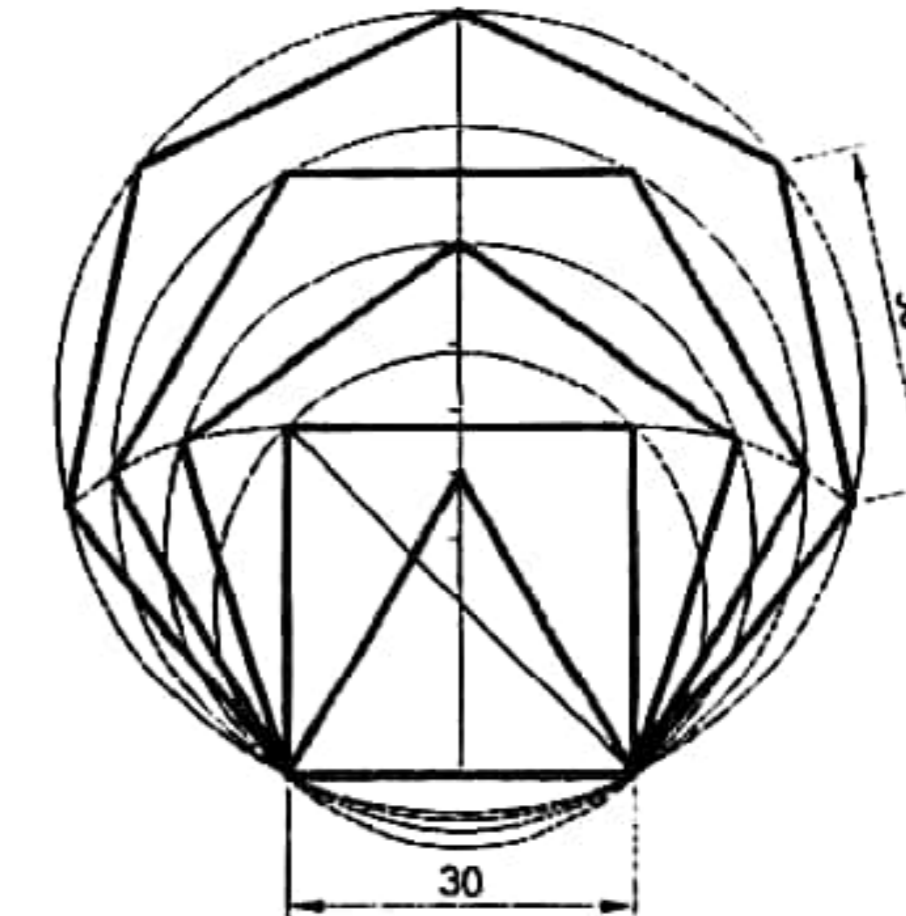
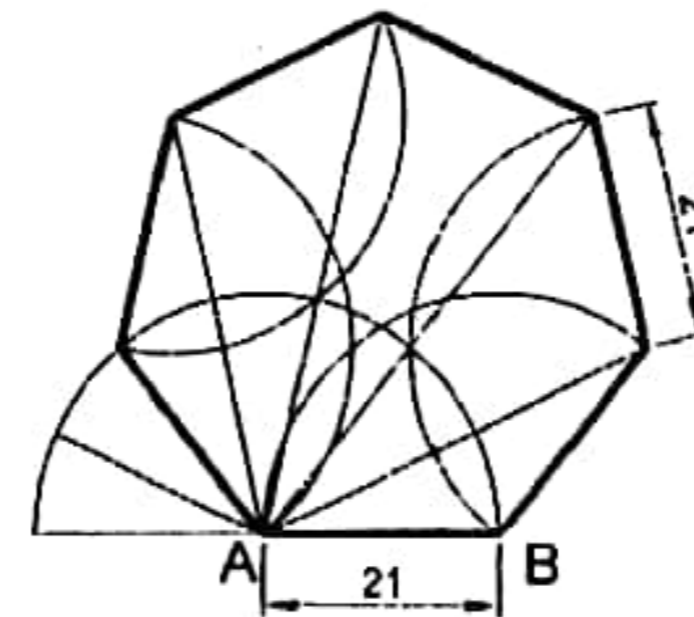
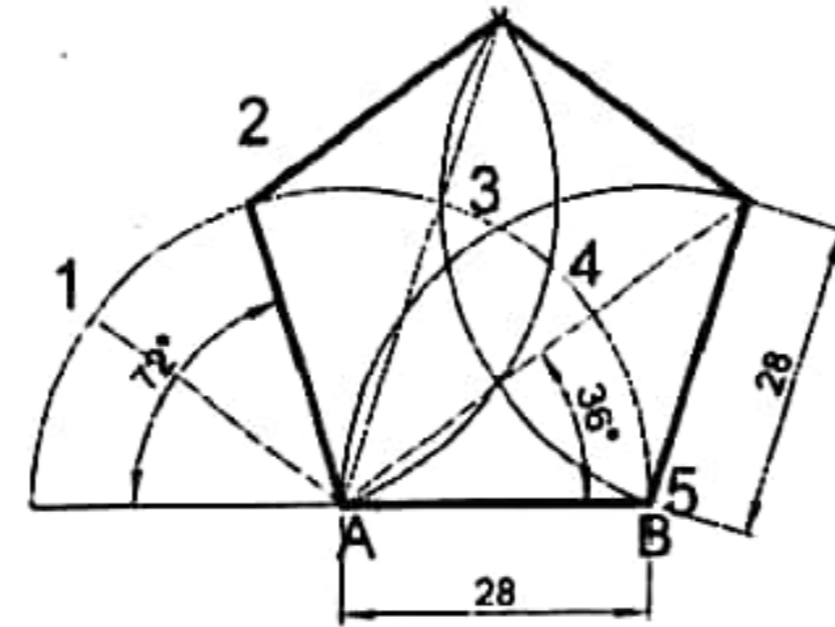

A CIRCLE DIVISION IN SEVEN EQUAL DIVISION(SECTOR)

POLYGON MAKING USING THE PROTRACTOR (HERE PENTAGON)

POLYGON MAKING USING THE PROTRACTOR (HERE HEPTAGON)

POLYGON'S NEST

SUBJECT

ENGINEERING DRAWING

TOPIC

DIVISION
LINE, ANGLE, CIRCLE, TRIANGLE
AND TRAPEZIUM

DRAWN BY

NAME
ROLL NO

CHECKED BY

DATE

DATE

SCALE

DRAWING NO

GC-1

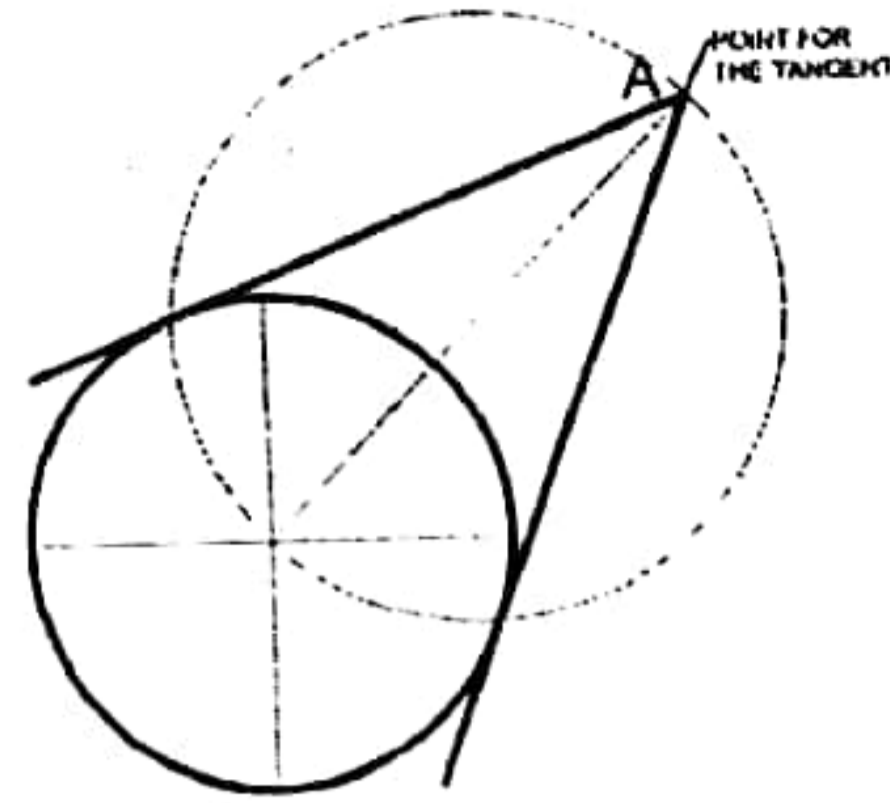

TANGENT TO A CIRCLE FROM ANY POINT

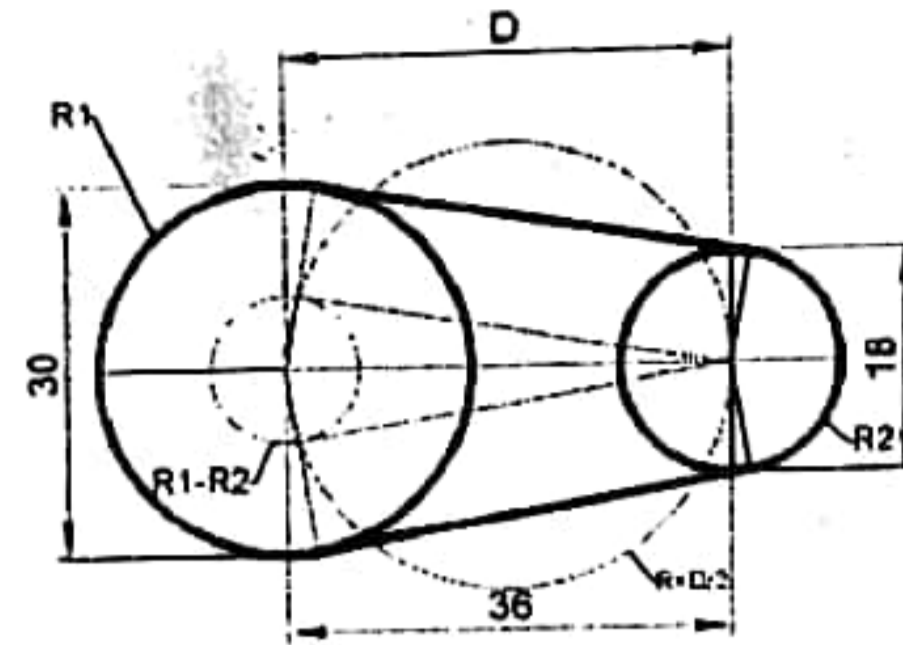

UNCROSSED (BELT) LINE (EXTERNAL) TANGENT BETWEEN TWO UNEQUAL CIRCLES.

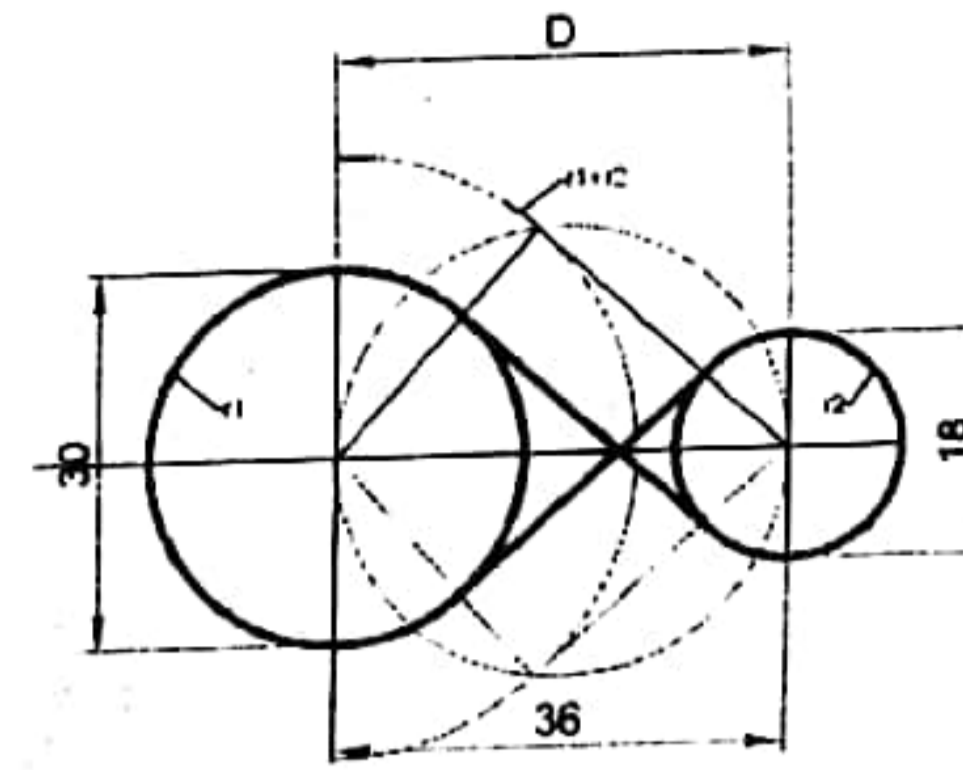

CROSSED (BELT) LINE (INTERNAL) TANGENT BETWEEN TWO UNEQUAL CIRCLES.

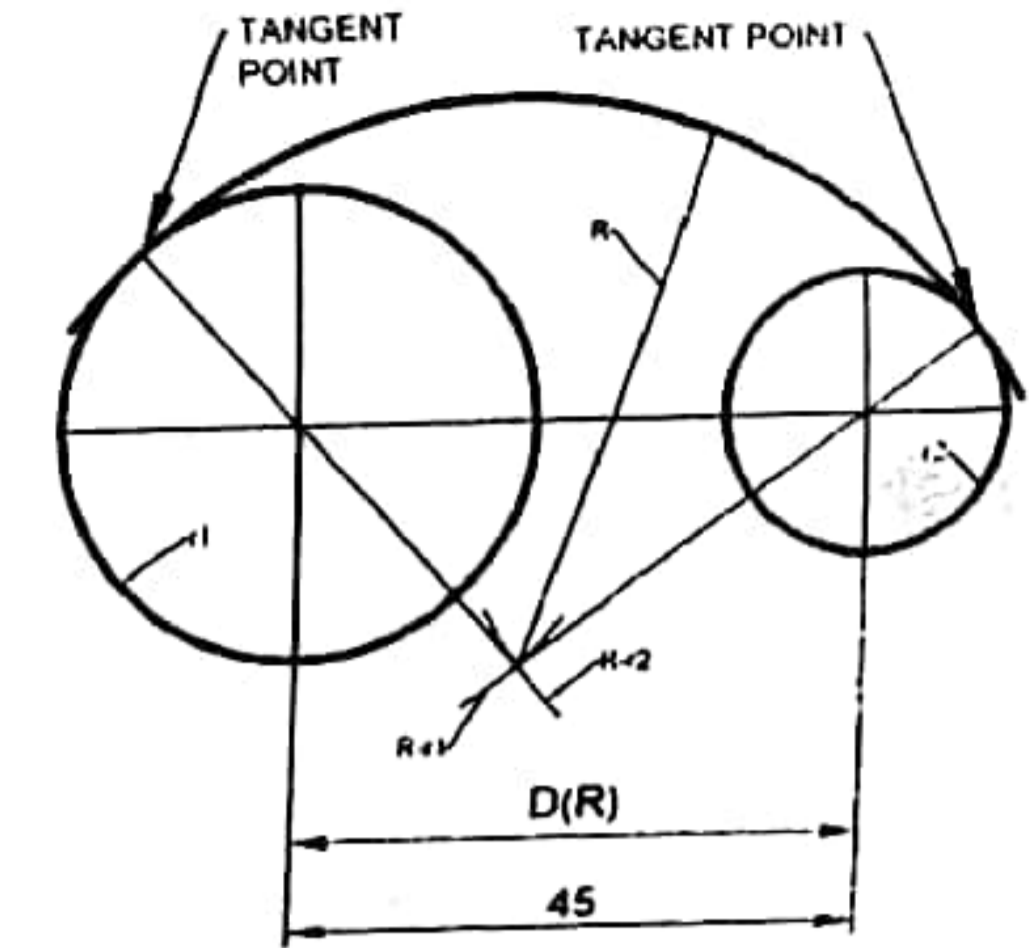

INTERNAL ARC TANGENT BETWEEN TWO UNEQUAL CIRCLES

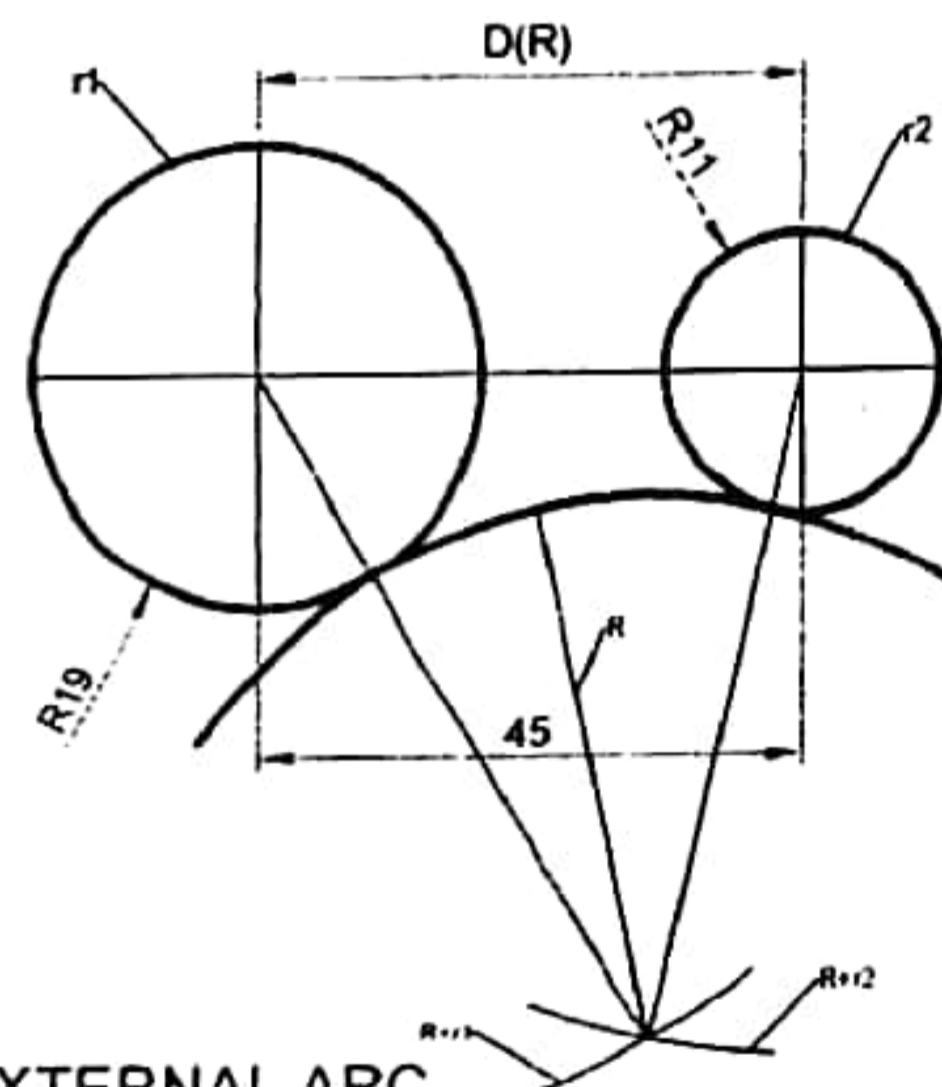

EXTERNAL ARC TANGENT BETWEEN TWO UNEQUAL CIRCLES

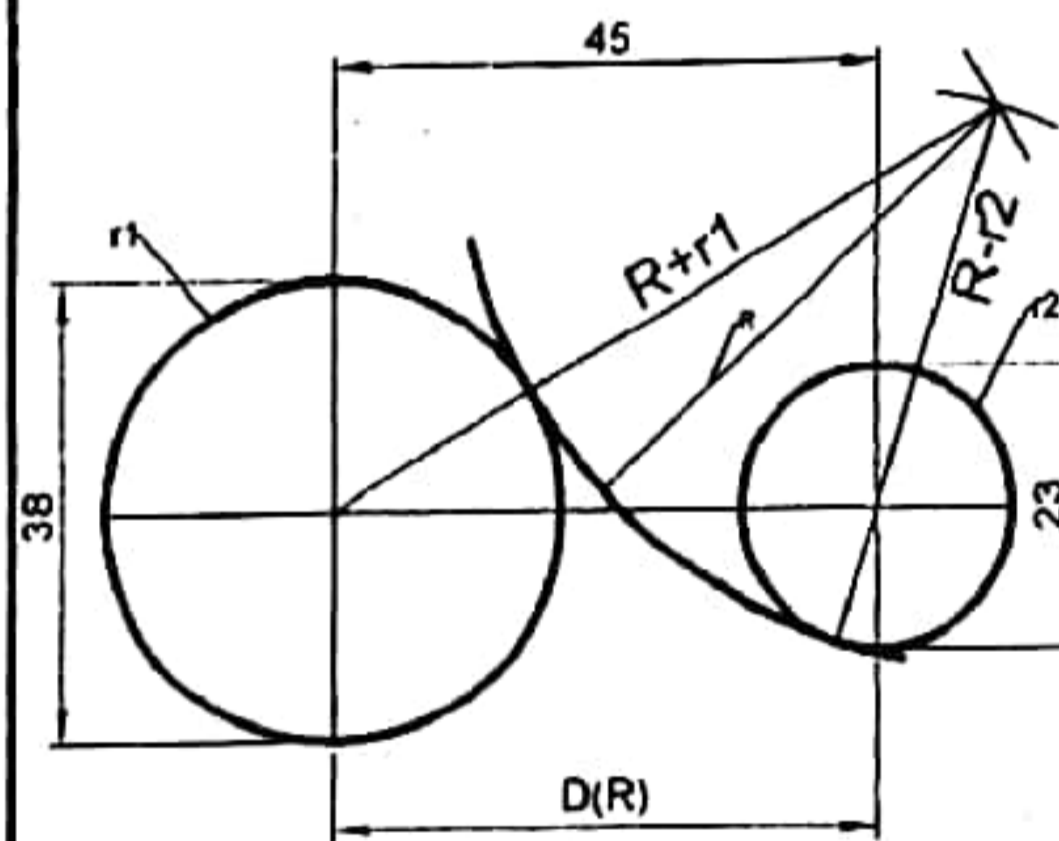

COMBINED ARC TANGENT BETWEEN TWO UNEQUAL CIRCLES

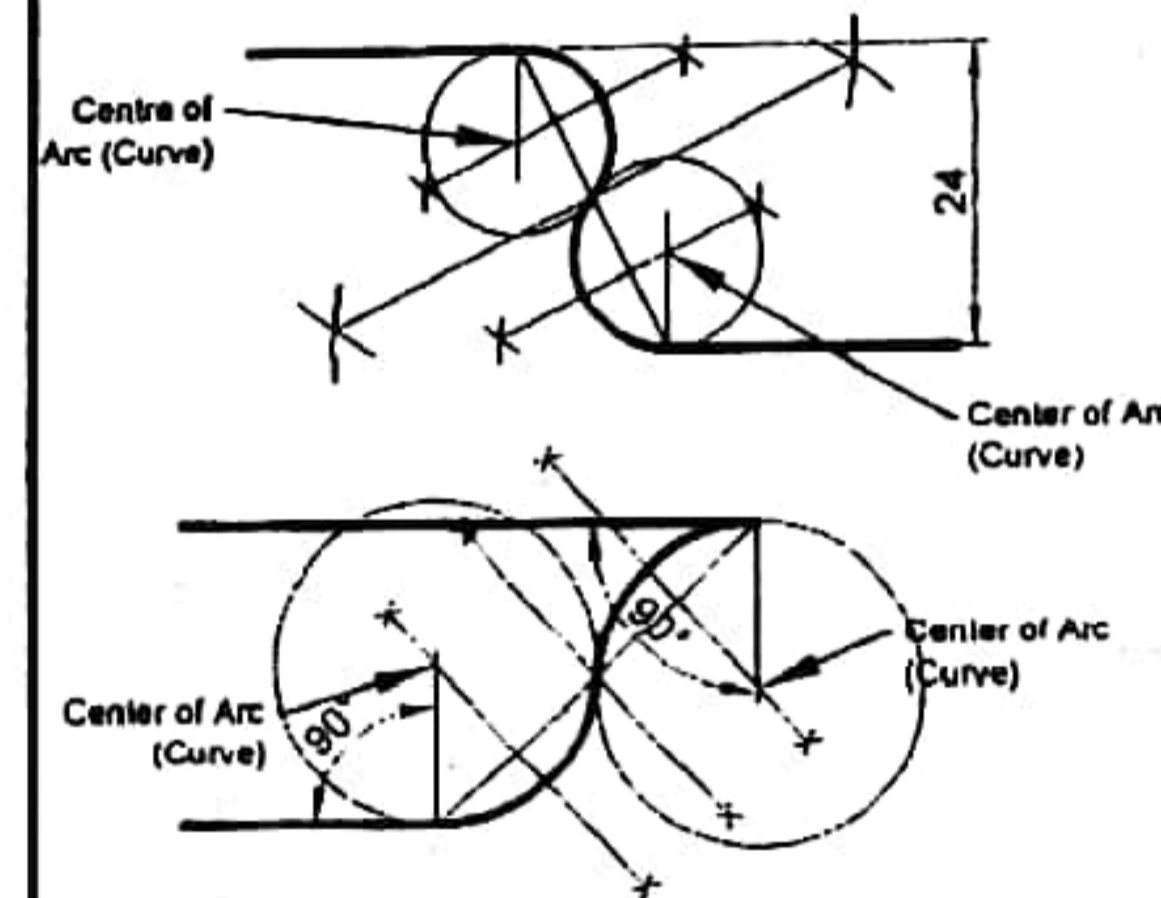

OGEE'S CURVE BETWEEN TWO PARALLEL LINE

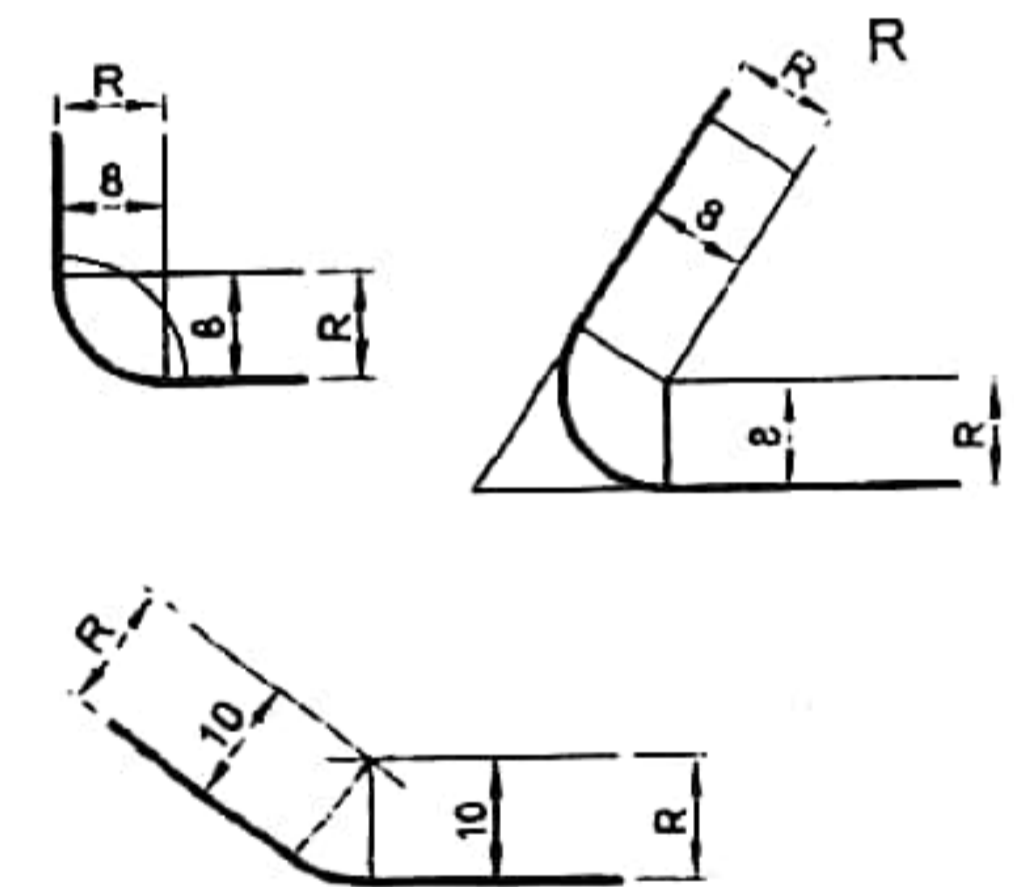

ARC TANGENT BETWEEN TWO STRAIGHT LINE

SUBJECT ENGINEERING DRAWING	TOPIC TANGENCY LINE AND ARC TANGENT	DRAWN BY NAME ROLL NO	CHECKED BY DATE	DATE	SCALE
				DRAWING NO GC-3	

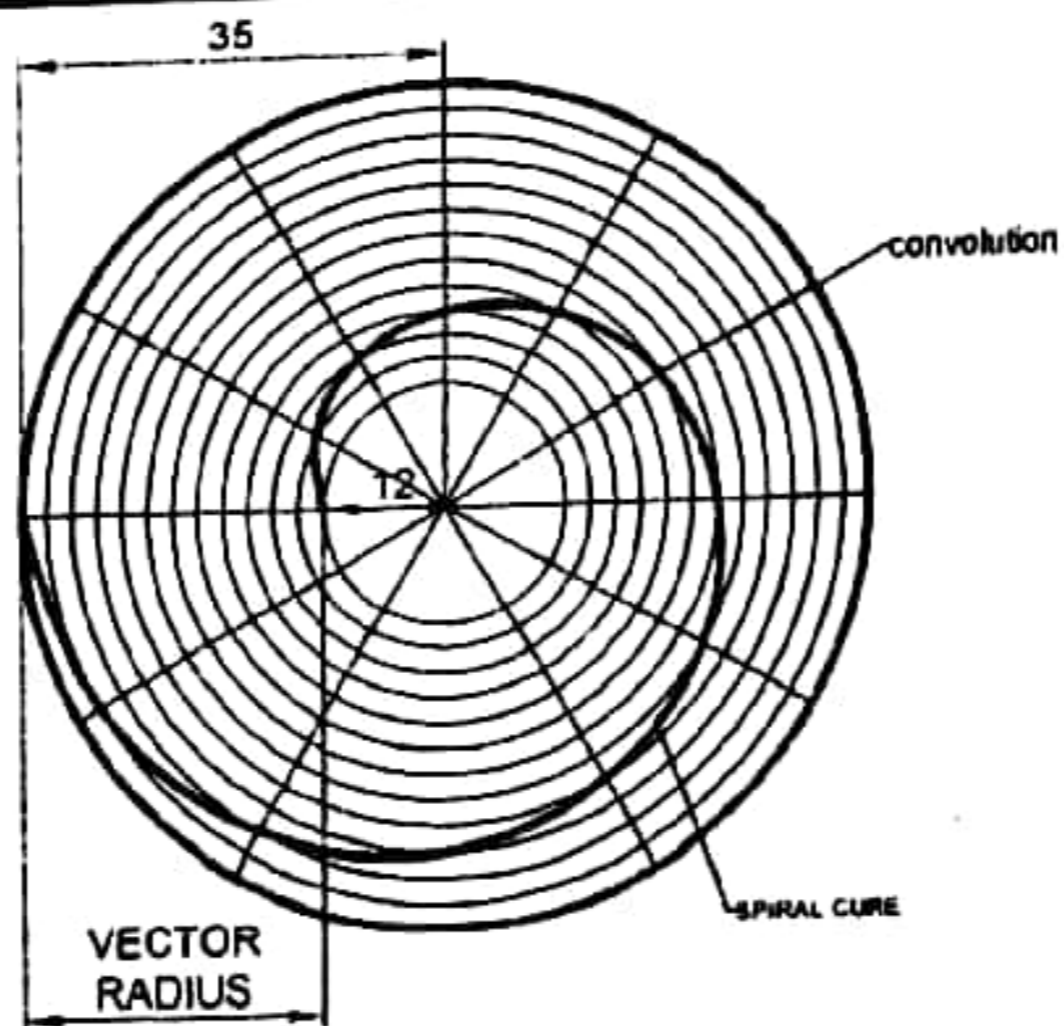
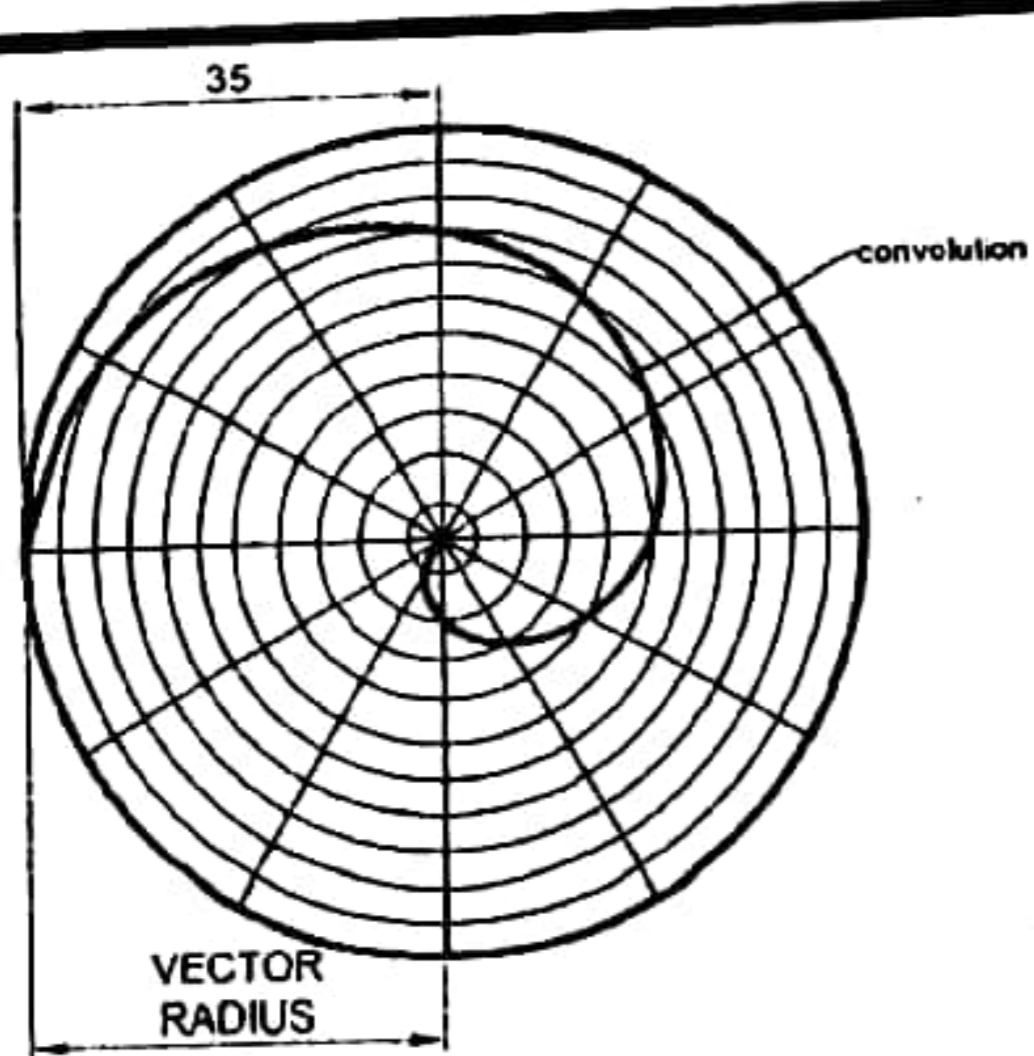

SPIRAL is the locus of a point moving along a line continuously in one direction, when the rotates in a plane about one of its ends both motions being regular.

SPIRAL CURVE

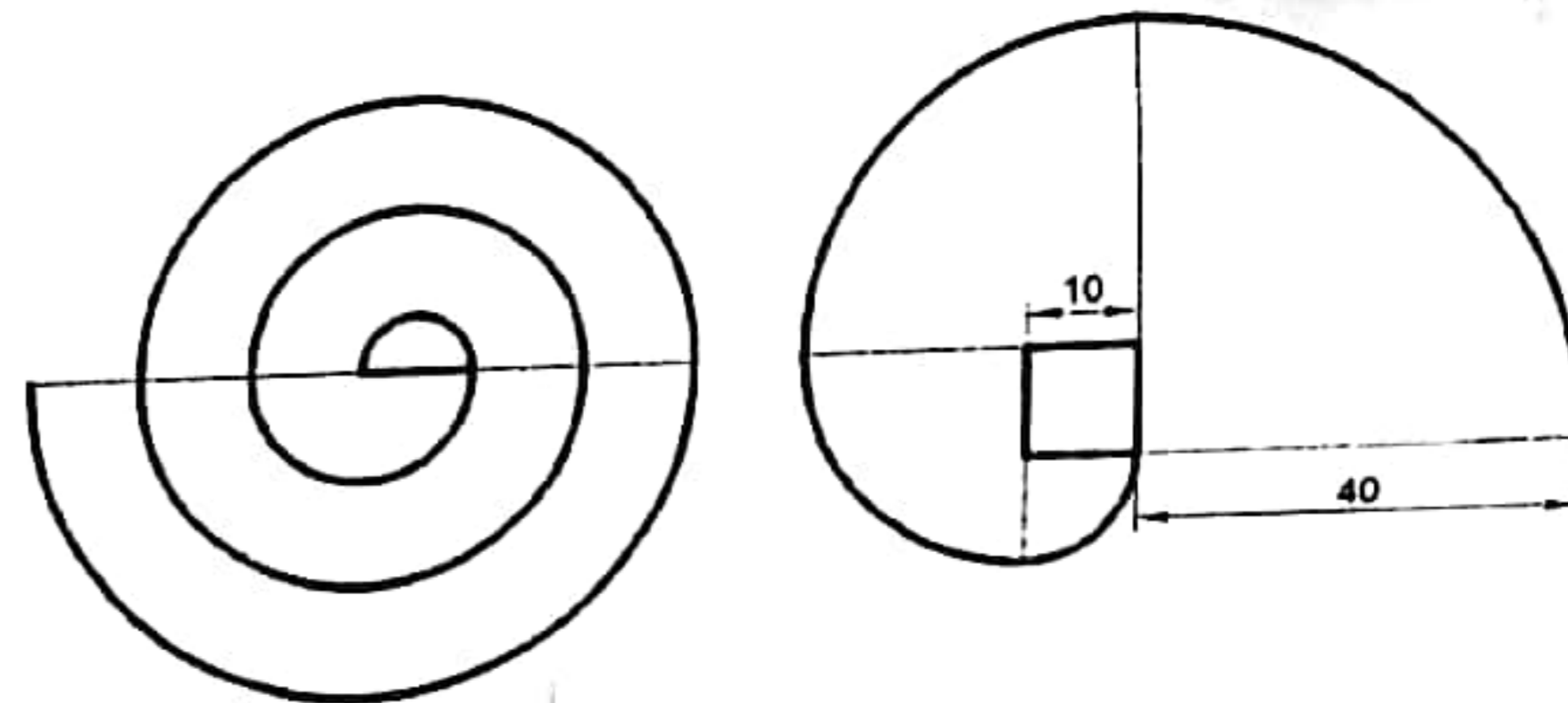

LINE INVOLUTE

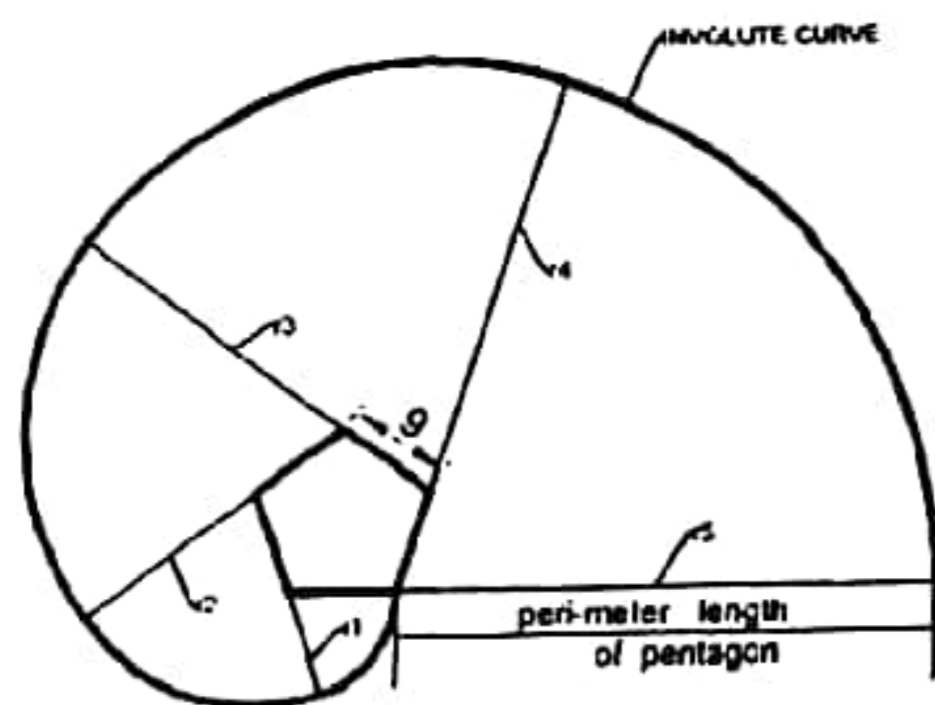

PENTAGONAL INVOLUTE

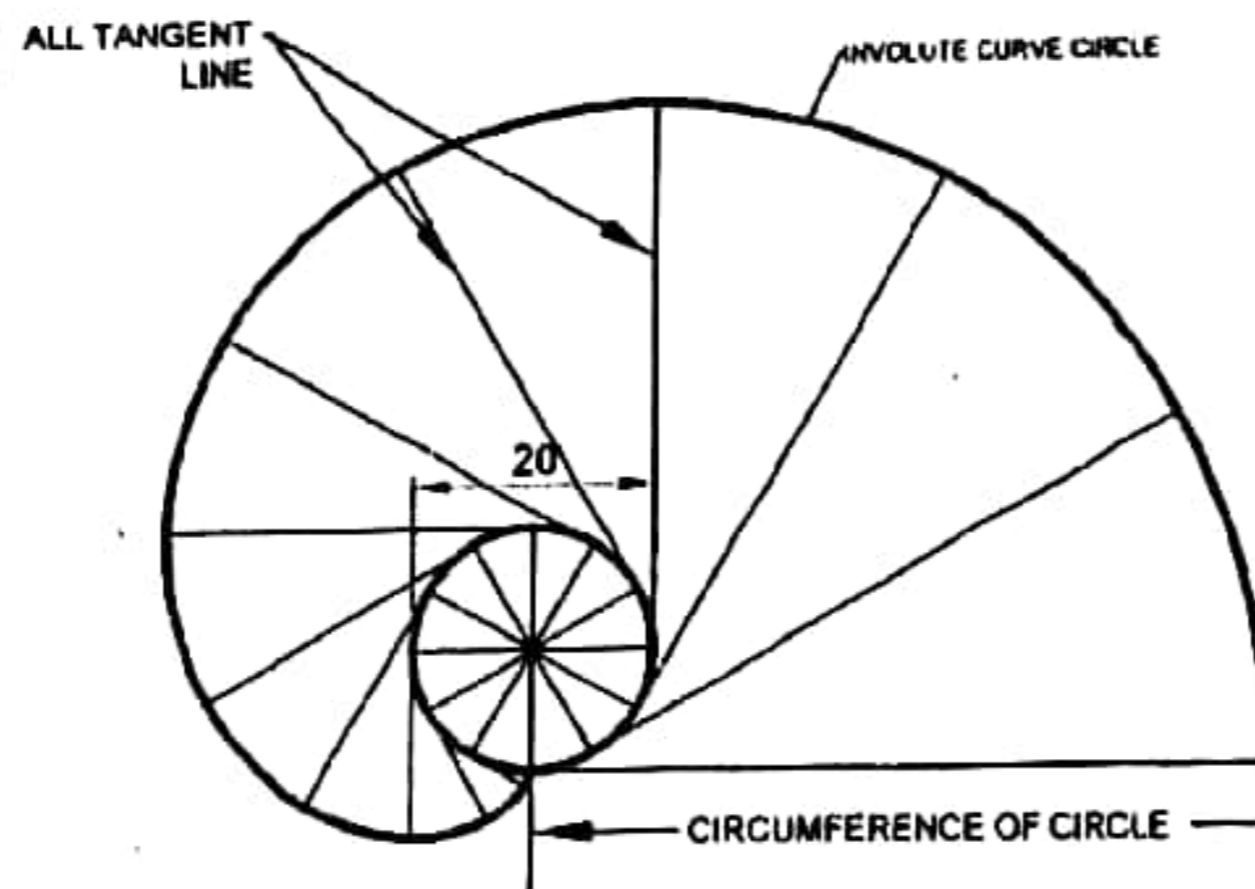

INVOLUTE IS A SINGLE CURVED LINE TRACED OUT BY AN END OF A STRING WHEN UNWOUND ITSELF FROM STRAIGHT LINE OR A CIRCLE OR POLYGON THE STRING BEING KEPT TAUT.

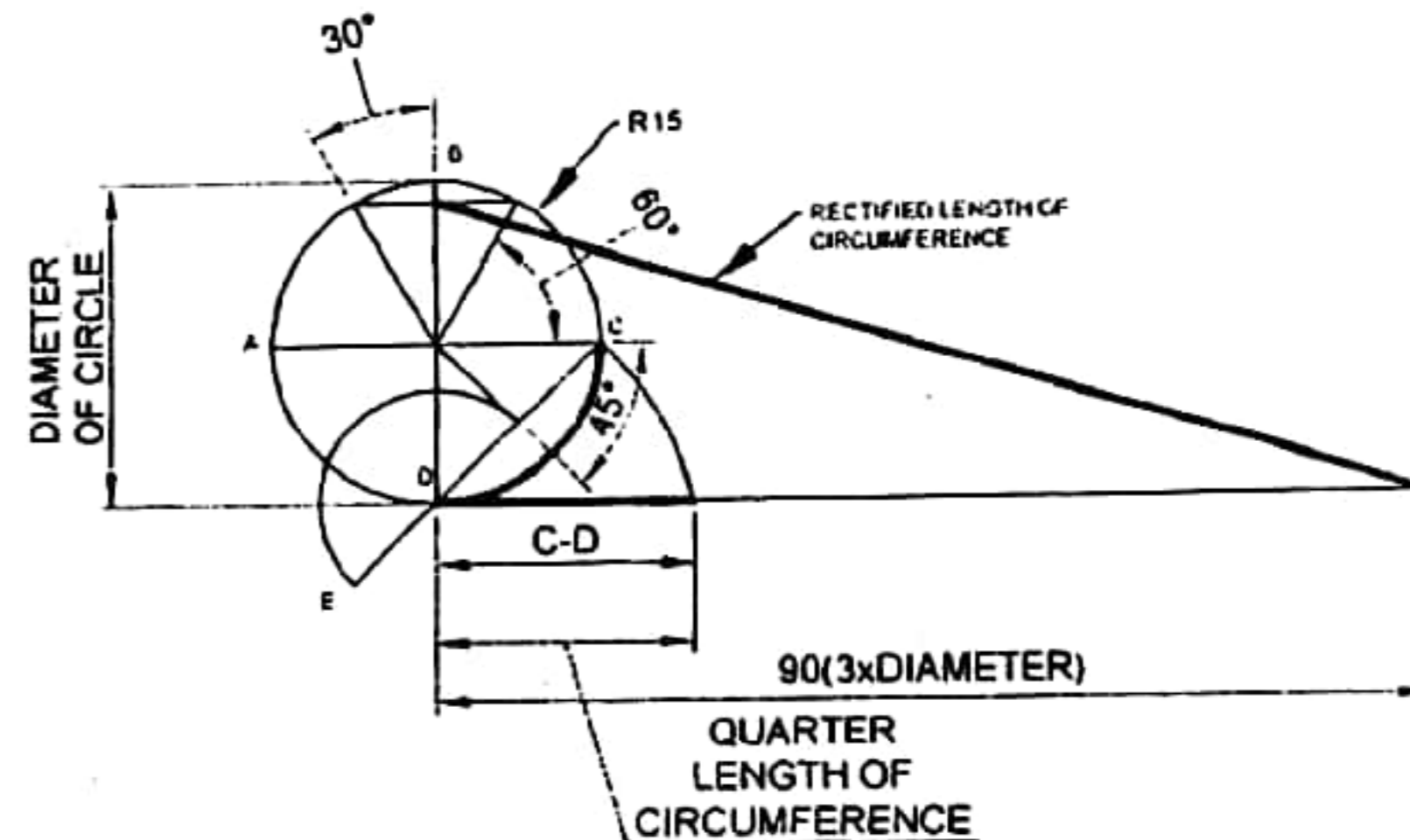

FINDING THE CIRCUMFERENCE LENGTH OF CIRCLE

SUBJECT ENGINEERING DRAWING	TOPIC CURVES SPIRAL, INVOLUTES, AND CIRCUMFERENCE LENGTH OF A CIRCLE	DRAWN BY NAME ROLL NO	CHECKED BY	DATE	SCALE
				DATE	DRAWING NO

WHEN A CIRCLE ROLLS ALONG A STRAIGHT LINE WITHOUT SLIPPING, THE LOCUS TRACED OUT BY ANY POINT OF THE CIRCUMFERENCE OF THE CIRCLE IS KNOWN AS CYCLOID

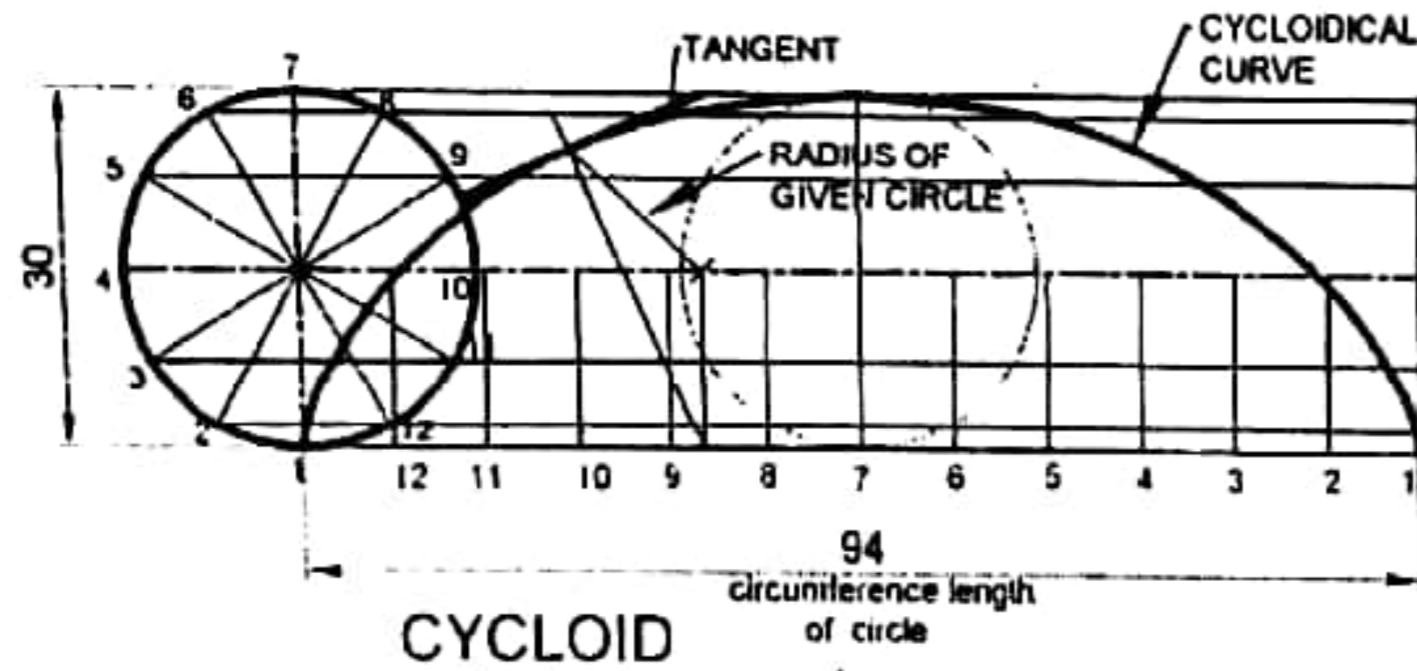

CYCLOID

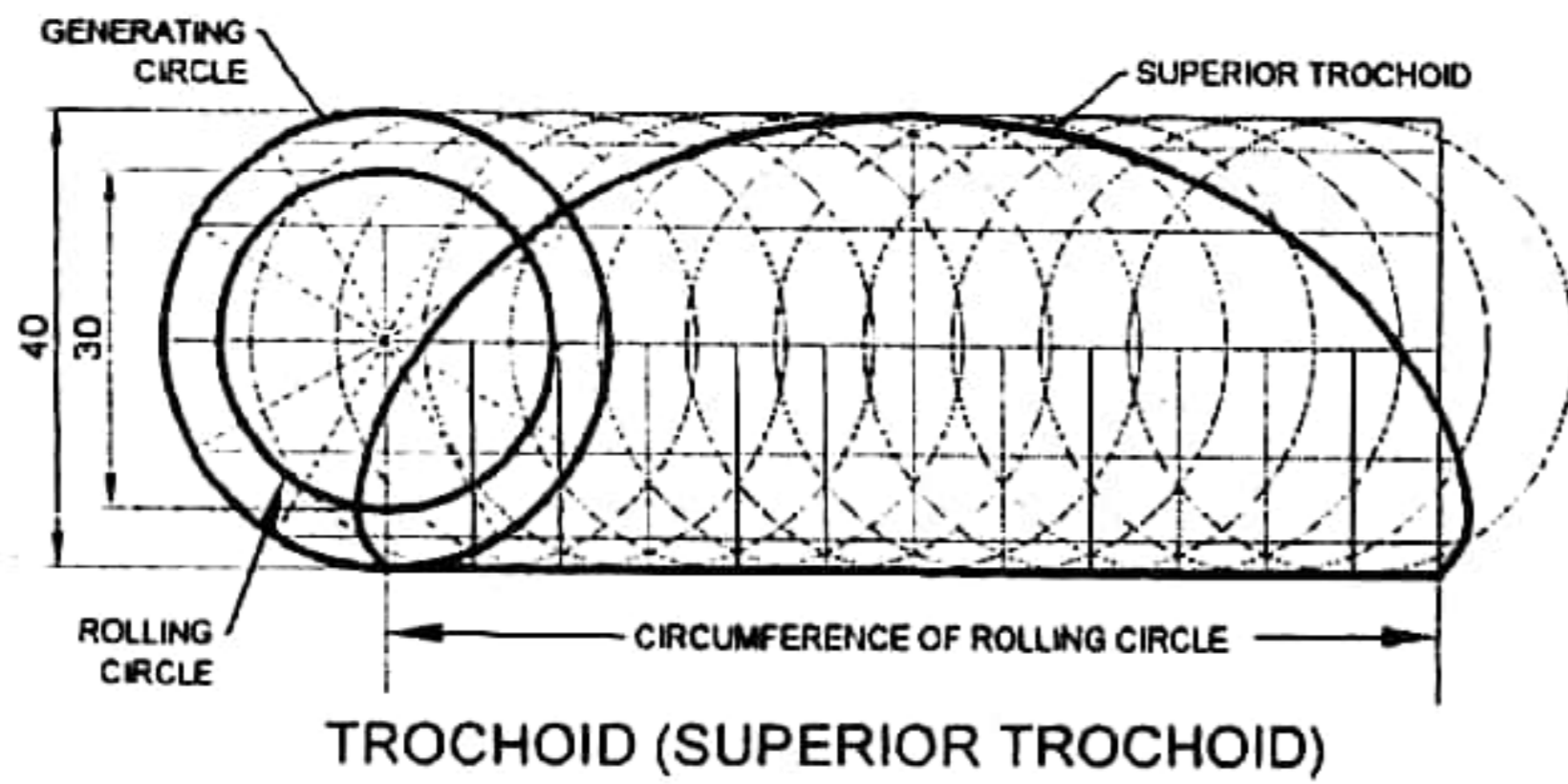

TROCHOID (SUPERIOR TROCHOID)

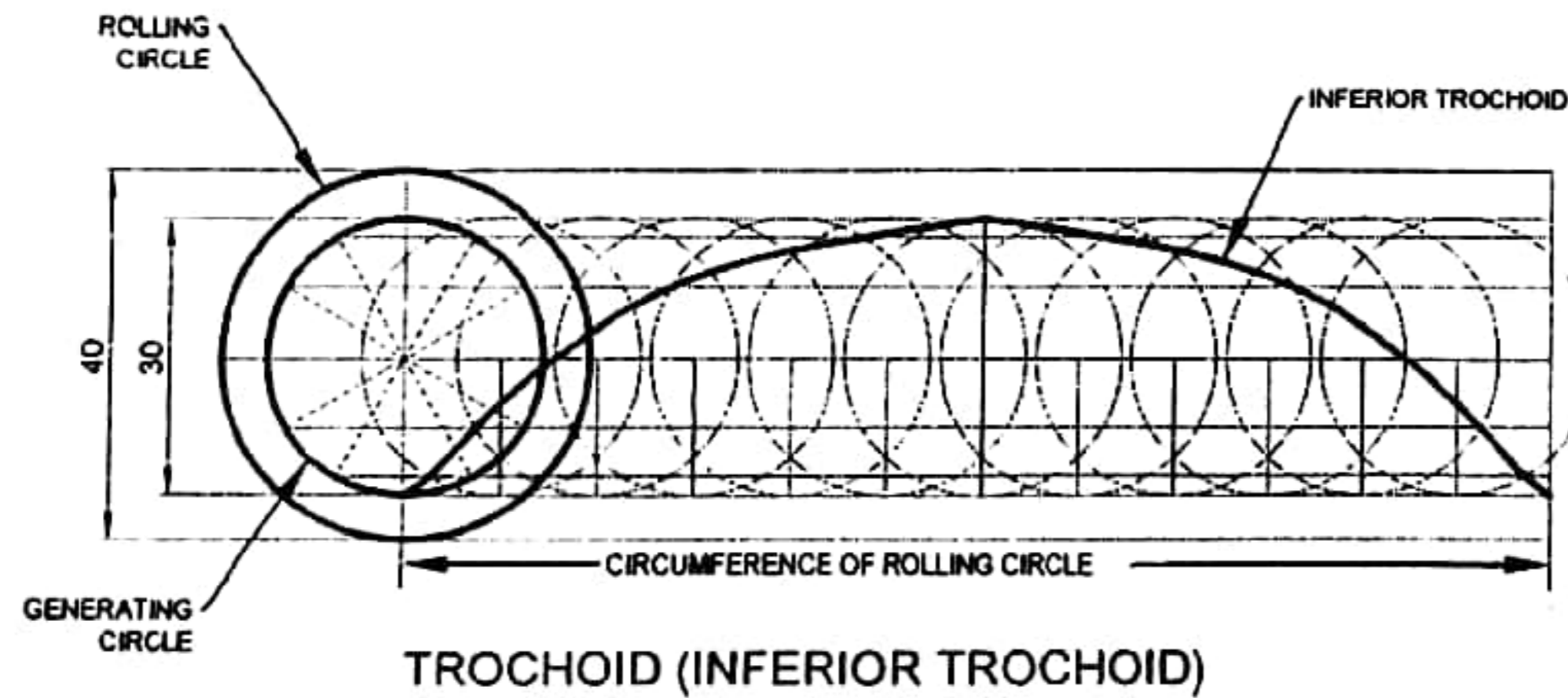

TROCHOID (INFERIOR TROCHOID)

EPICYCLOID IS A CURVE TRACED BY A POINT ON THE CIRCUMFERENCE OF A CIRCLE WHICH ROLLS WITHOUT SLIPPING ON THE OUTSIDE OF ANOTHER CIRCLE.

HYPOCYCLOID IS A CURVE TRACED BY A POINT ON THE CIRCUMFERENCE OF A CIRCLE WHICH ROLLS WITHOUT SLIPPING ON THE INSIDE OF ANOTHER CIRCLE.

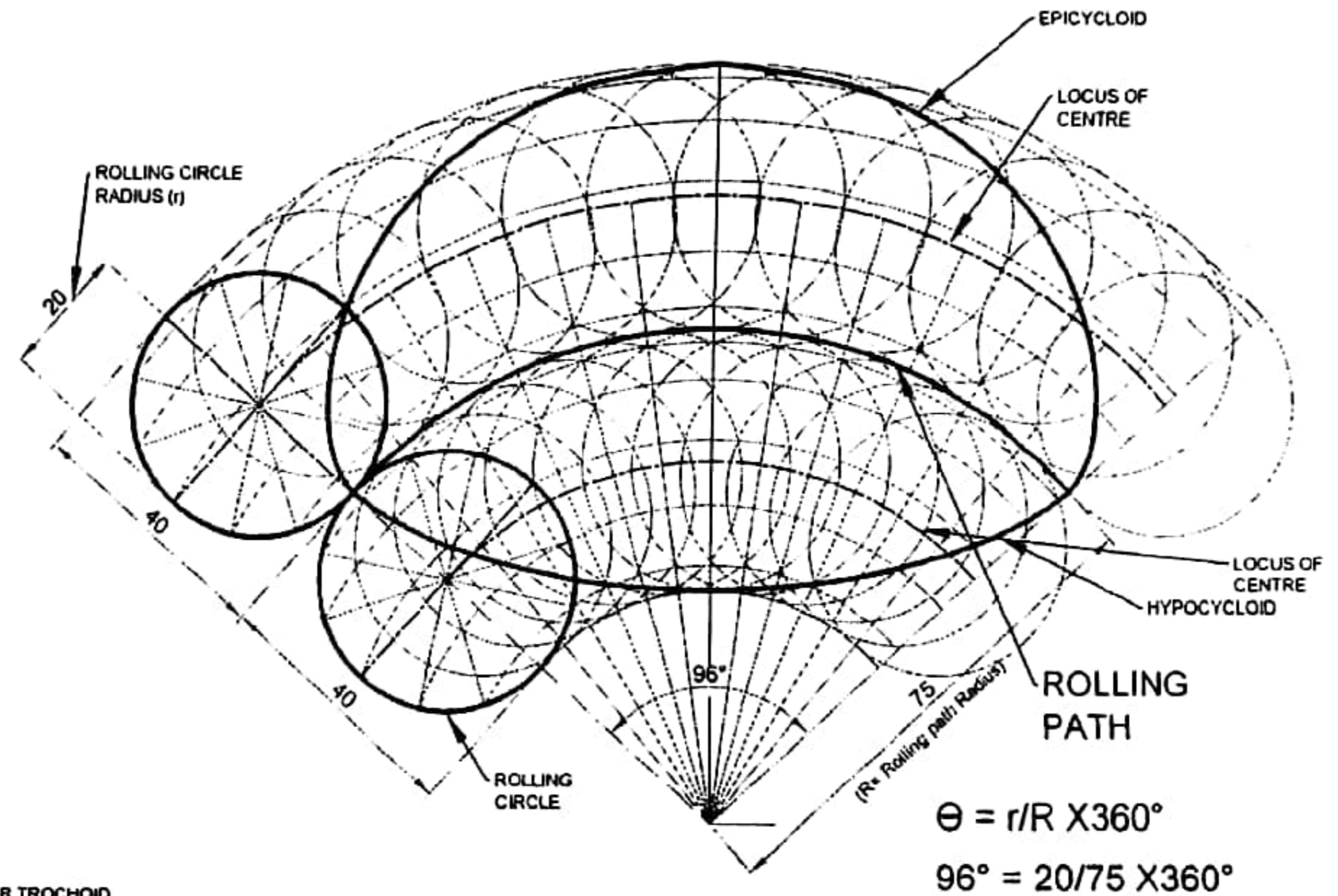

TROCHOID IT IS A CURVE TRACED OUT BY A POINT FIXED TO A CIRCLE, INSIDE OR OUTSIDE ITS CIRCUMFERENCE, AS THE CIRCLE ROLLS WITHOUT SLIPPING ALONG A STRAIGHT LINE.

IF THE POINT LIES OUTSIDE THE ROLLING CIRCLE, THE CURVE TRACED BY THE POINT IS CALLED AS SUPERIOR TROCHOID.

IF THE POINT LIES INSIDE THE ROLLING CIRCLE, THE CURVE TRACED BY THE POINT IS CALLED AS INFERIOR TROCHOID.

SUBJECT ENGINEERING DRAWING	TITLE CYCLOIDICAL CURVES	DRAWN BY NAME ROLL NO	CHECKED BY	DATE	SCALE
				DATE	DRAWING NO GC-5

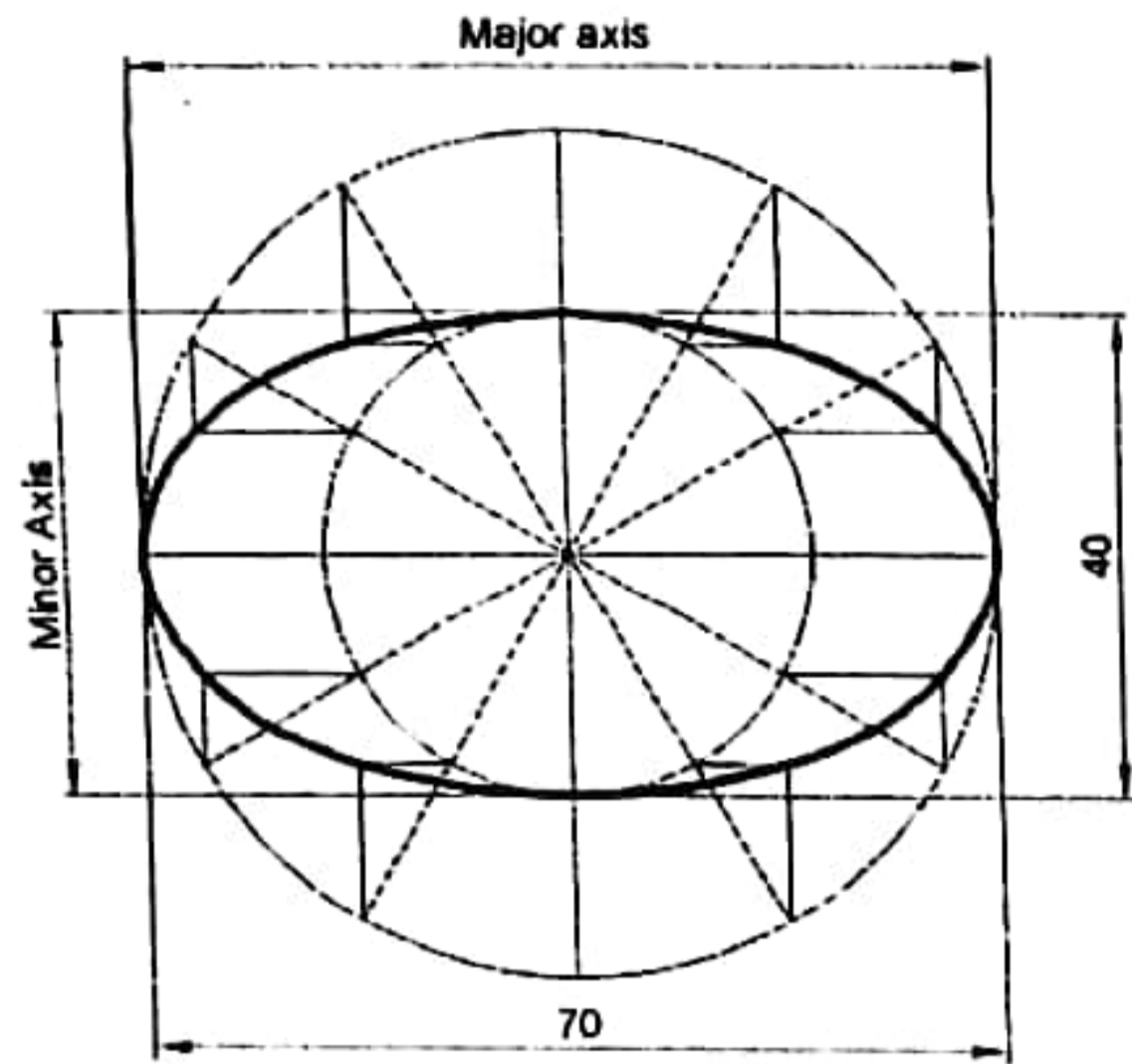

ELLIPSE CONSTRUCT BY CONCENTRIC CIRCLE METHOD

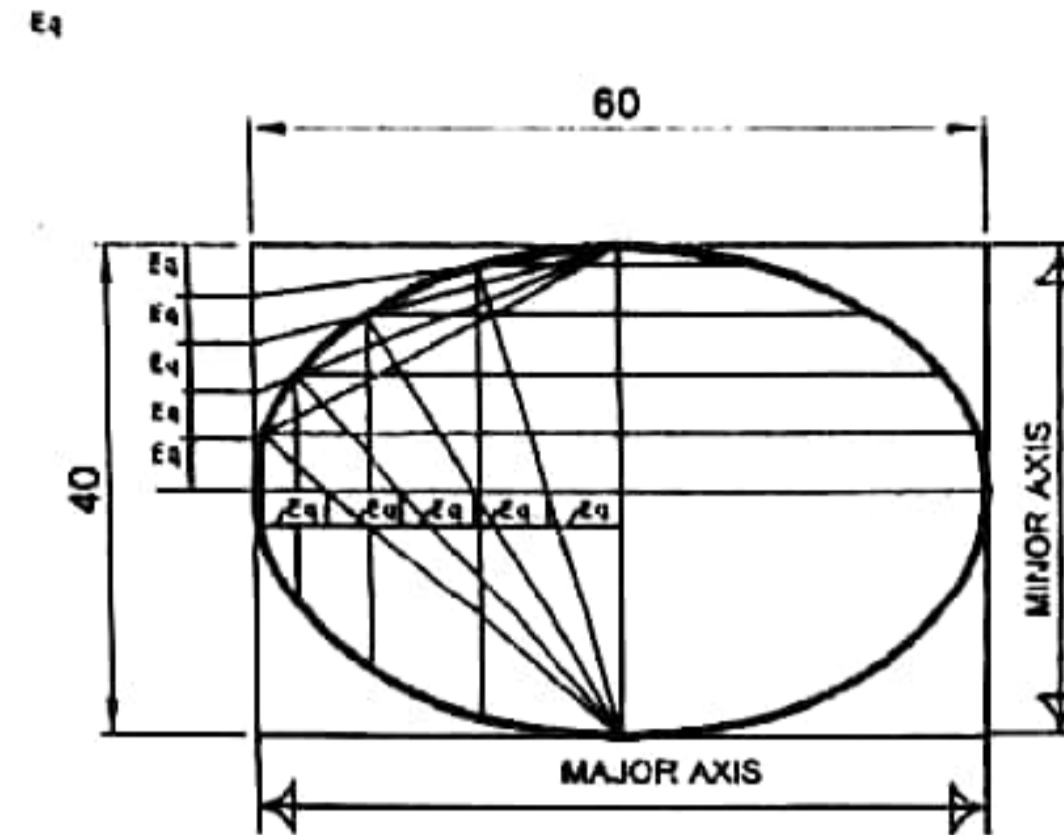

ELLIPSE CONSTRUCT BY OBLONG (RECTANGLE) METHOD

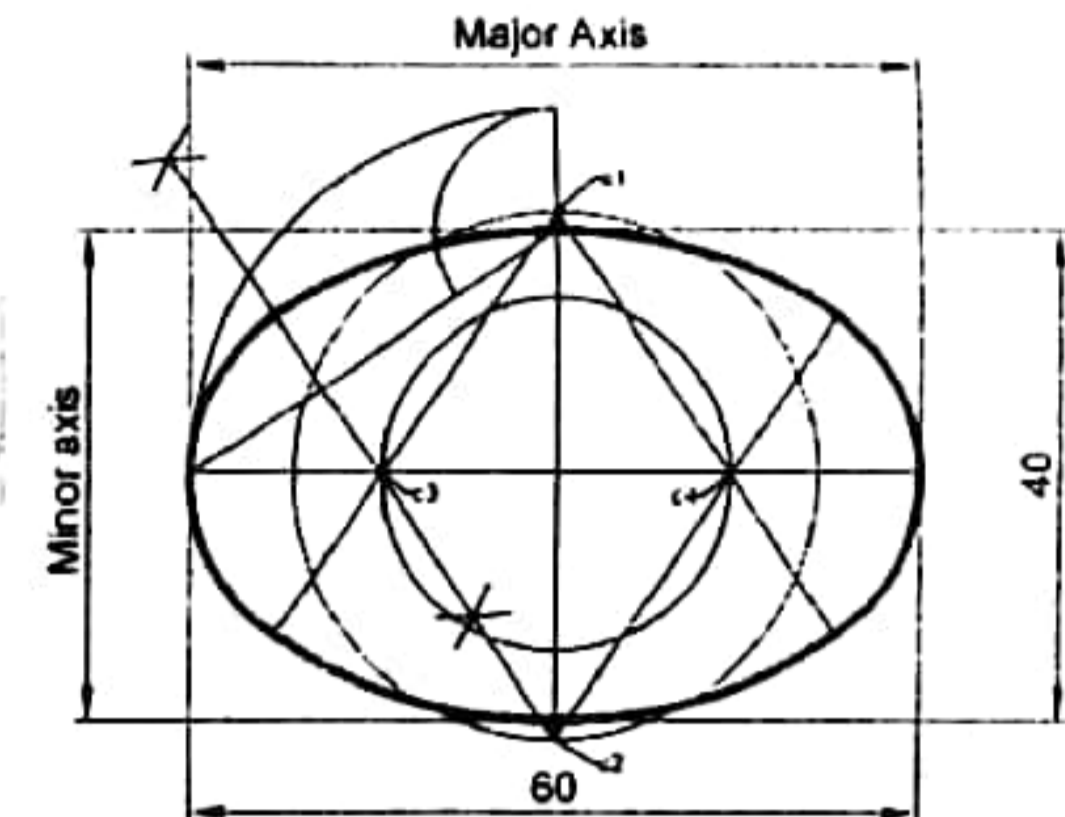

ELLIPSE CONSTRUCT BY FOUR CENTER METHOD

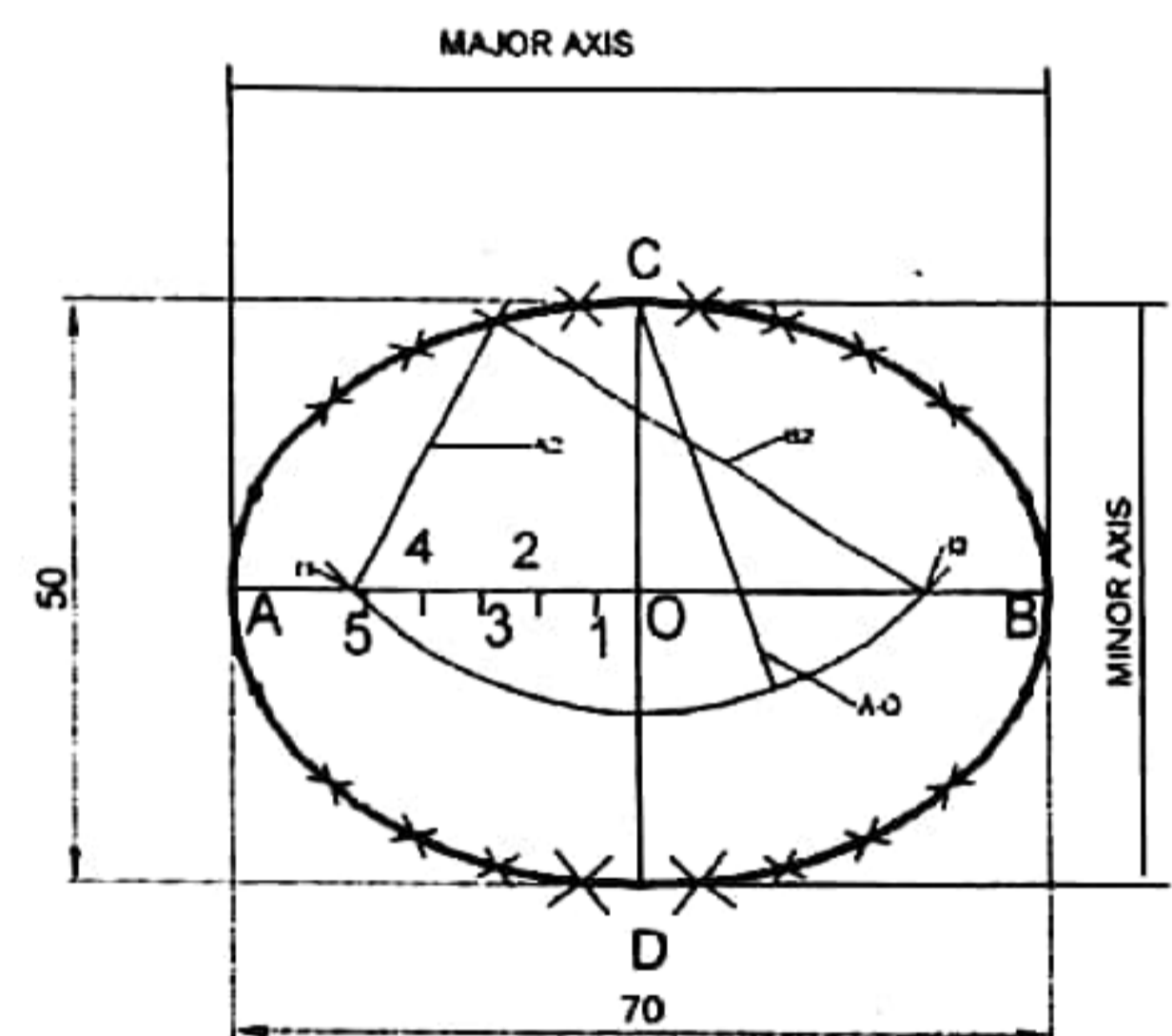

ELLIPSE CONSTRUCT BY FOCI CENTER METHOD $f_1 = f_2 = \text{Focus}$

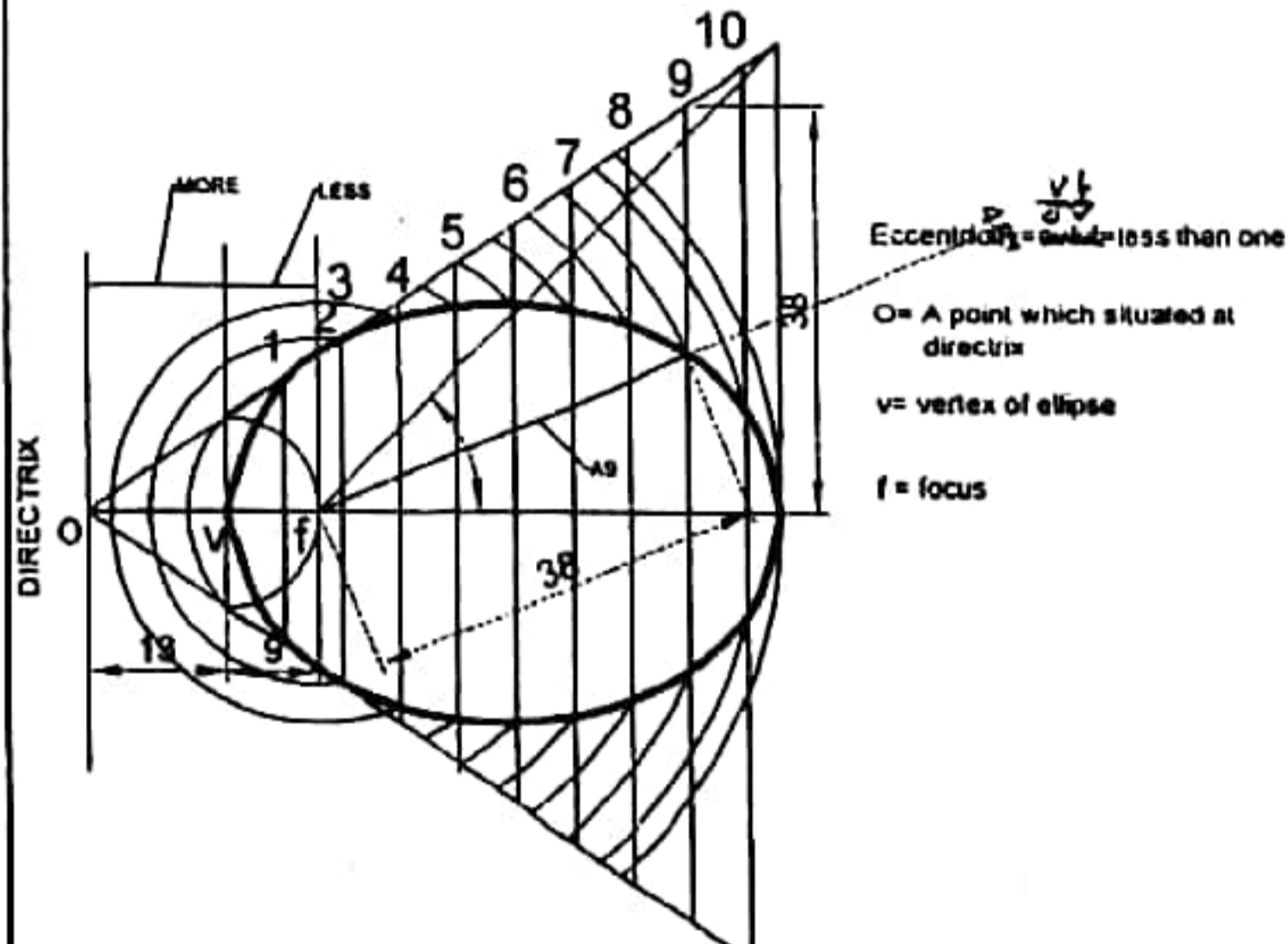

ELLIPSE CONSTRUCT BY ECCENTRICITY METHOD

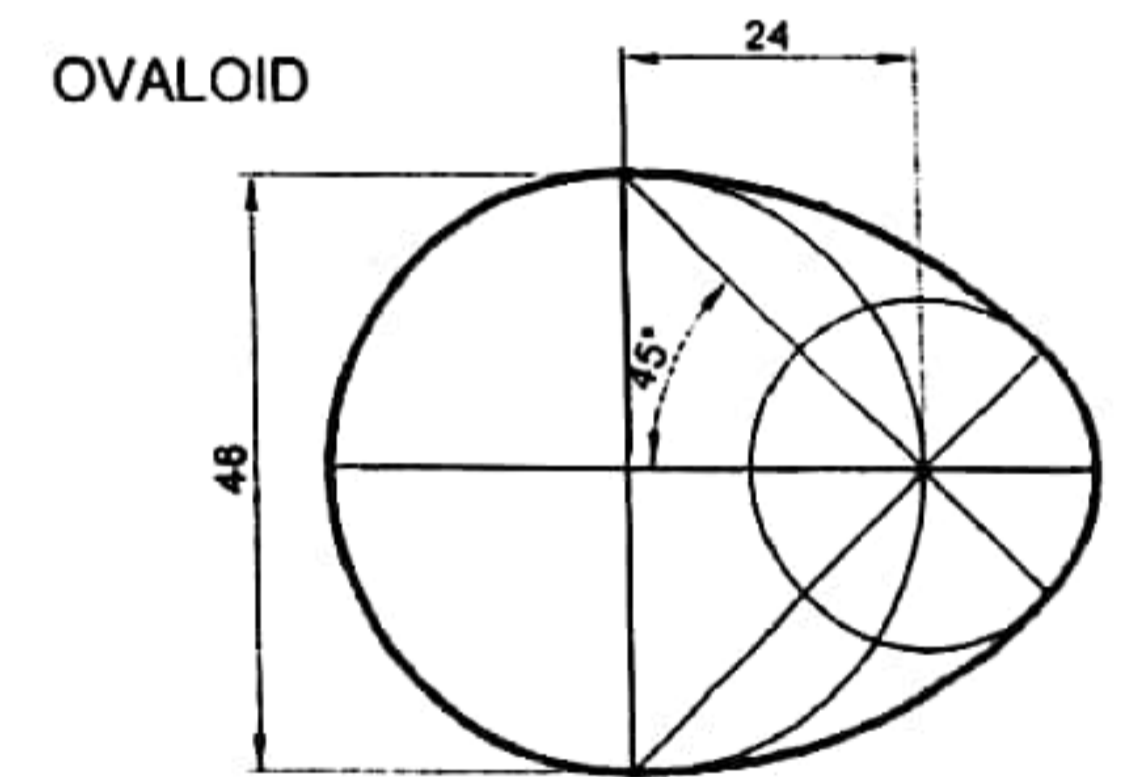

WHEN A RIGHT CONE IS CUT BY SECTIONAL PLANE IN DIFFERENT POSITION THERE WILL OCCUR FIVE TYPE OF CURVE BY ITS BOUNDARY SEEN ON NEW CUTTING AREA. THE NAMES OF DIFFERENT CURVE ARE CIRCLE, ELLIPSE, PARABOLA, HYPERBOLA AND ISOSCELES TRIANGLE.

SUBJECT ENGINEERING DRAWING	TOPIC CONIC SECTIONS ELLIPSE, PARABOLA AND HYPERBOLA	DRAWN BY NAME ROLL NO	CHECKED BY	DATE	SCALE
				DRAWING NO	GC/CS-1

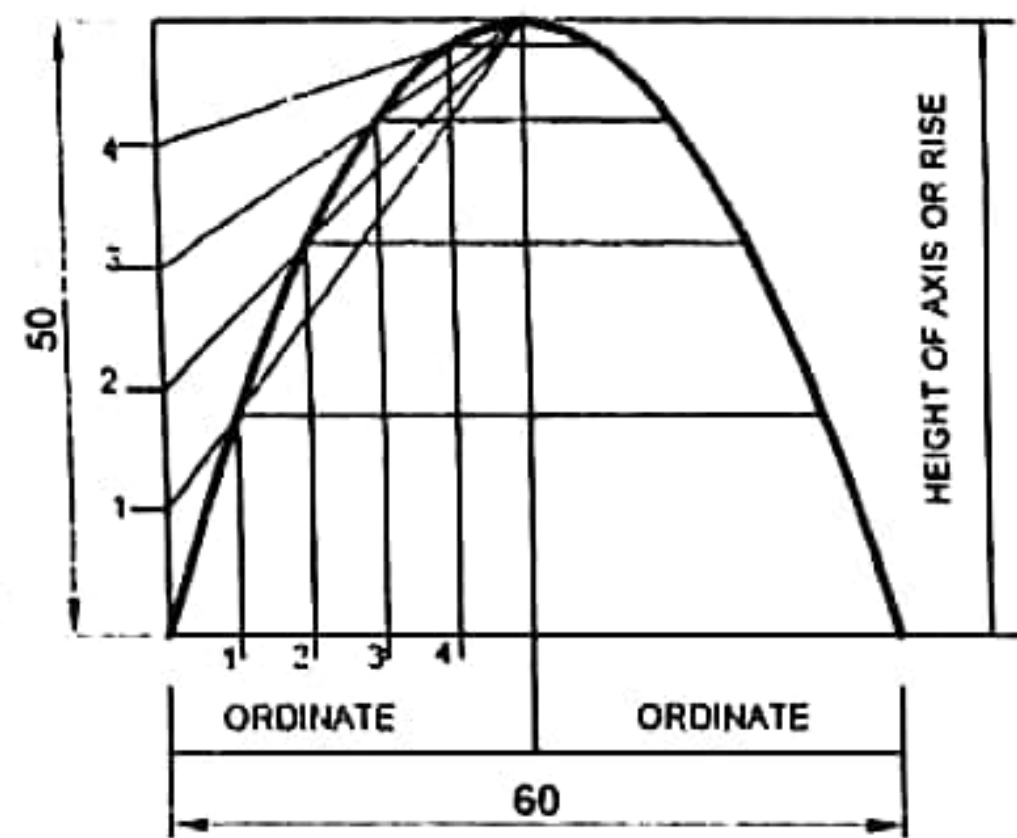

PARABOLA CONSTRUCT BY RECTANGLE METHOD

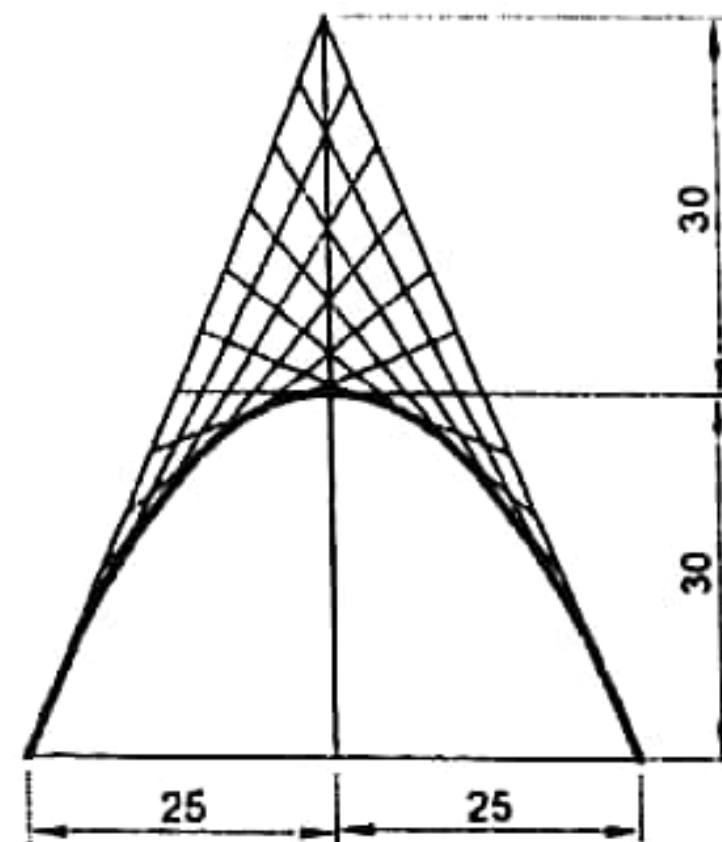

PARABOLA CONSTRUCT BY TANGENT METHOD

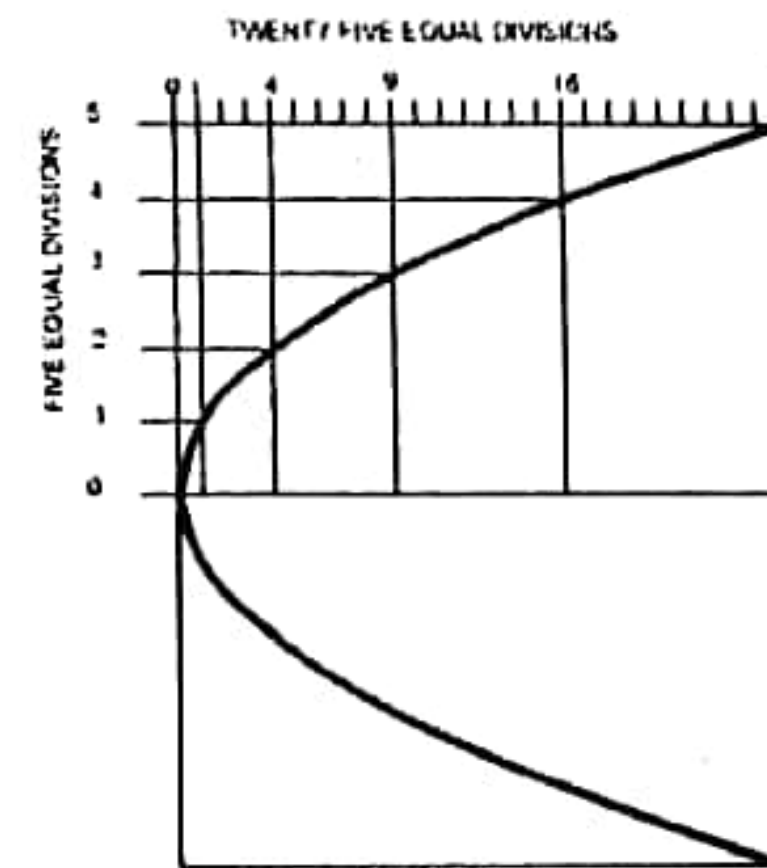

PARABOLA CONSTRUCT BY OFFSET METHOD

Eccentricity = ov/vf = equal to one
 O = A point which is situated at directrix
 v = vertex of parabola
 f = focus

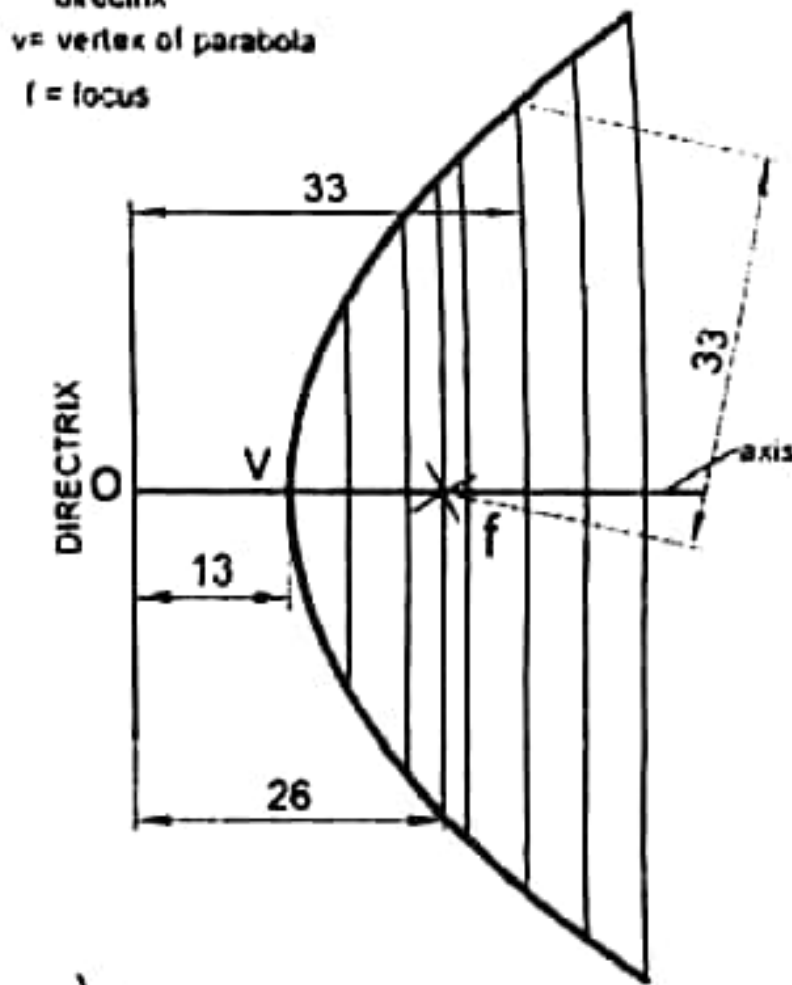

PARABOLA CONSTRUCT BY ECCENTRICITY METHOD

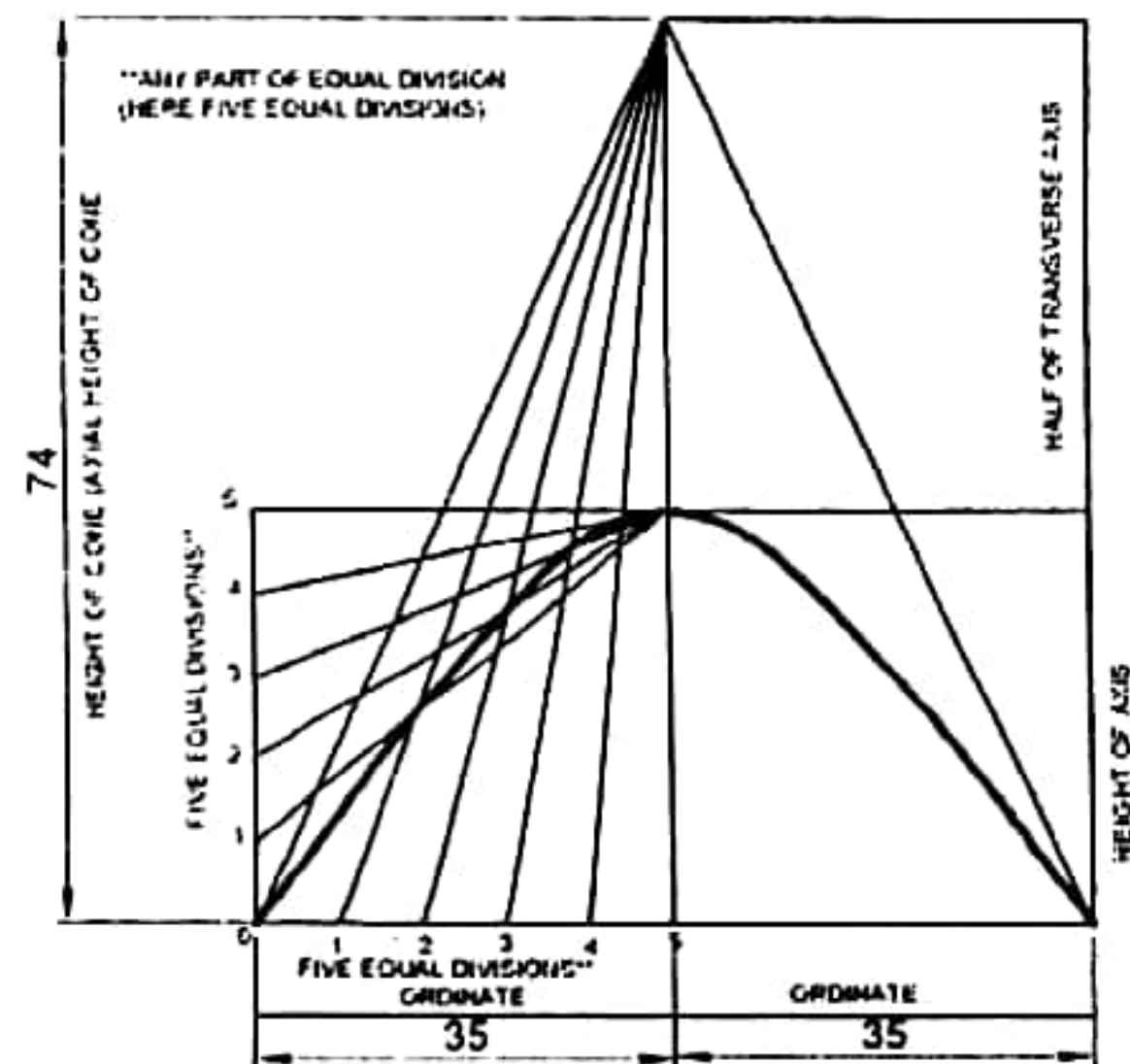

HYPERBOLA CONSTRUCT WHEN HEIGHT OF AXIS, HALF OF TRANSVERSE AXIS AND ORDINATE GIVEN.

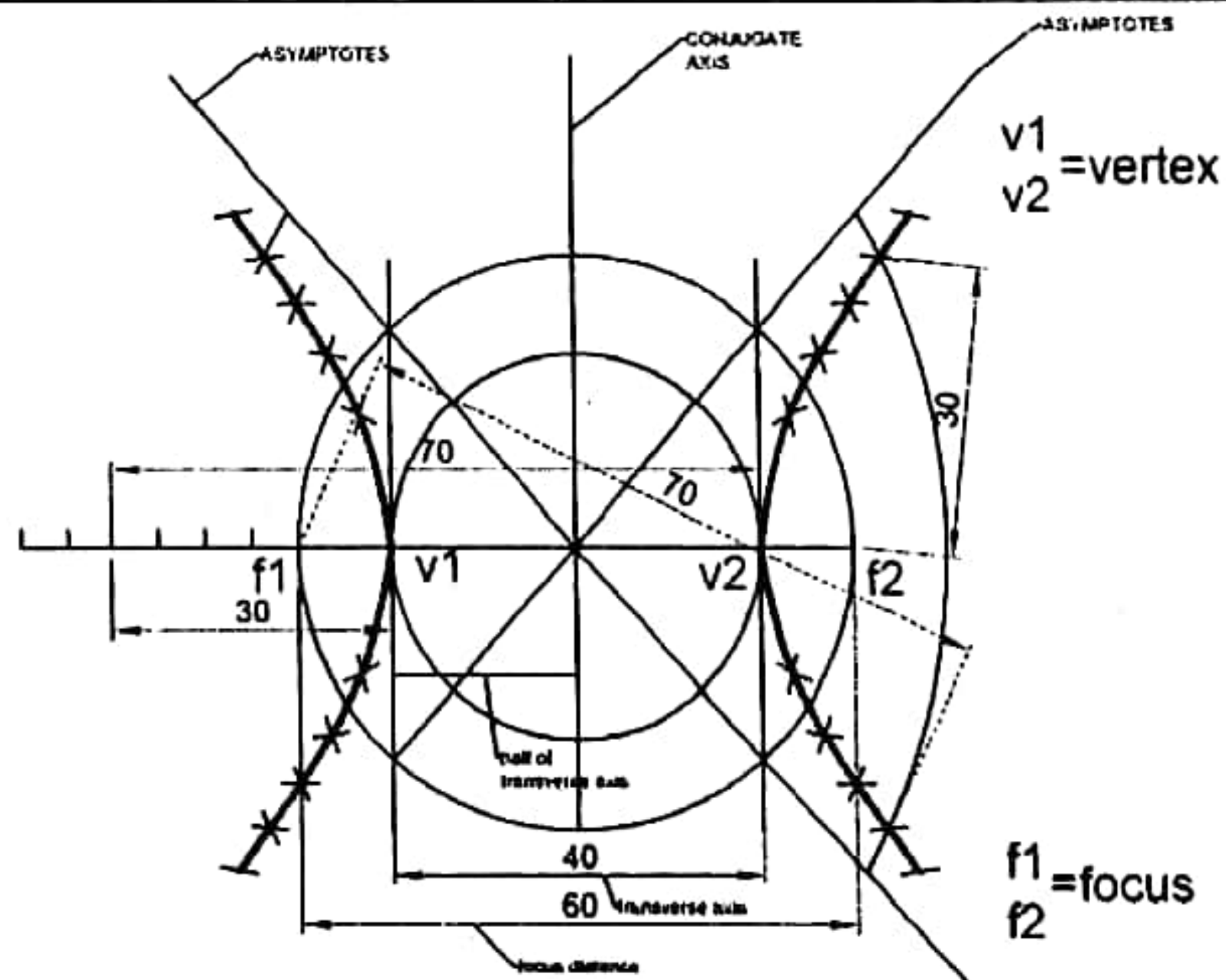

HYPERBOLA CONSTRUCT WHEN DISTANCE BETWEEN TWO VERTICES AND TWO FOCI GIVEN.

Eccentricity = ov/vf = greater than one
 O = A point which is situated at directrix
 v = vertex of hyperbola
 f = focus

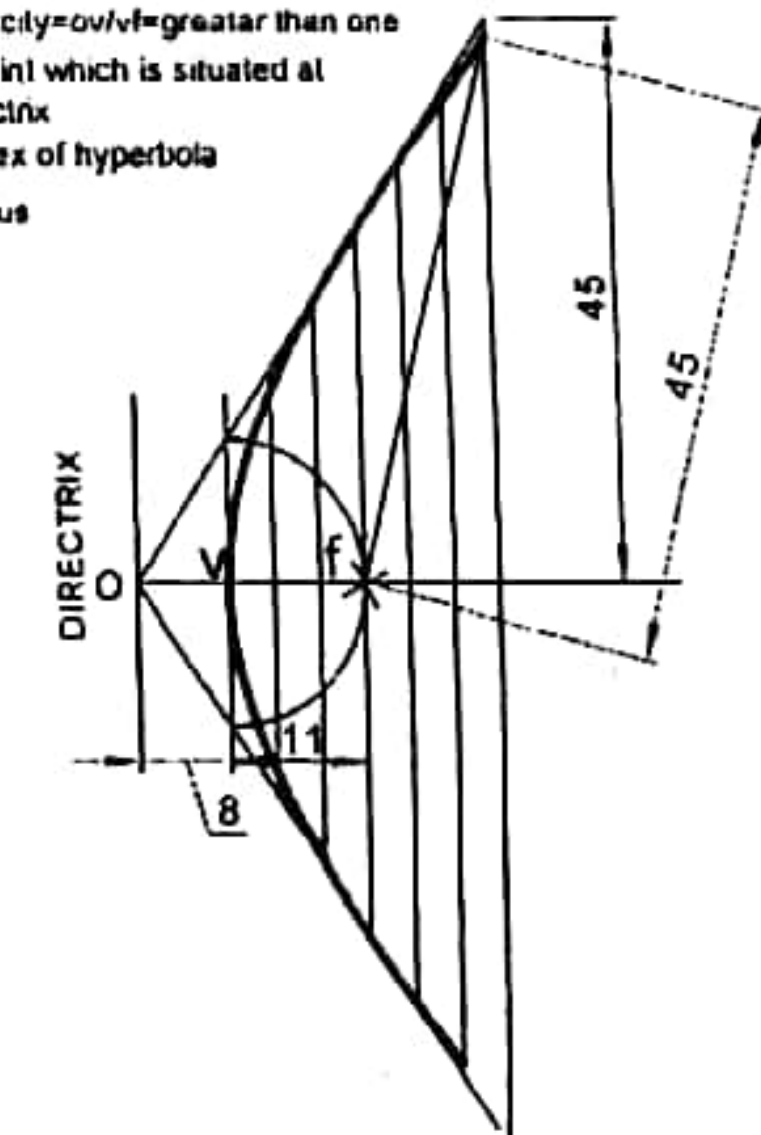

HYPERBOLA CONSTRUCT BY ECCENTRICITY METHOD

SUBJECT
 ENGINEERING DRAWING

TOPIC
 CONIC SECTIONS
 PARABOLA AND HYPERBOLA

DRAWN BY
 NAME
 ROLL NO

CHECKED BY
 DATE

DATE
 DRAWING NO

SCALE
 GC/CS-2

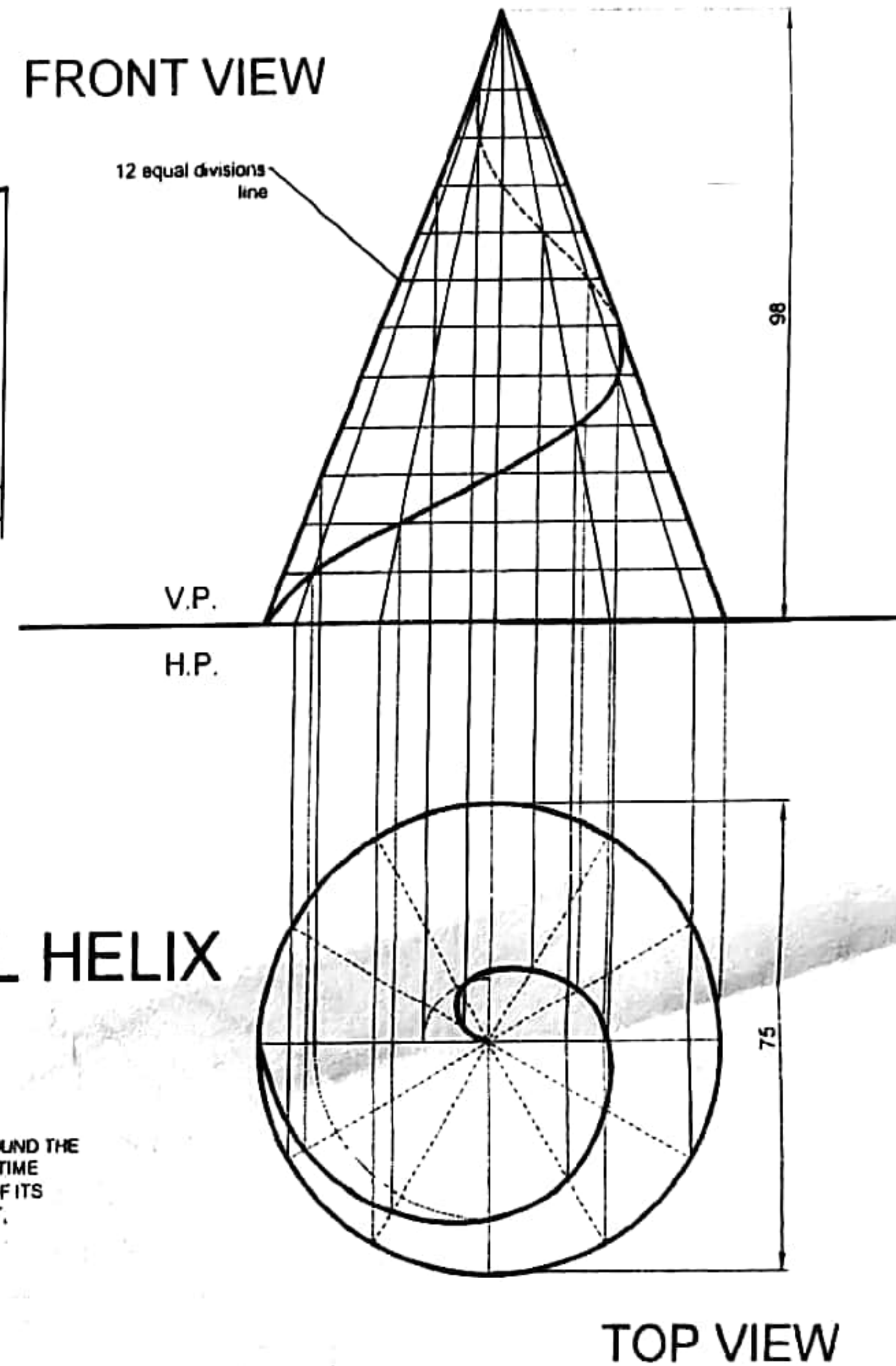
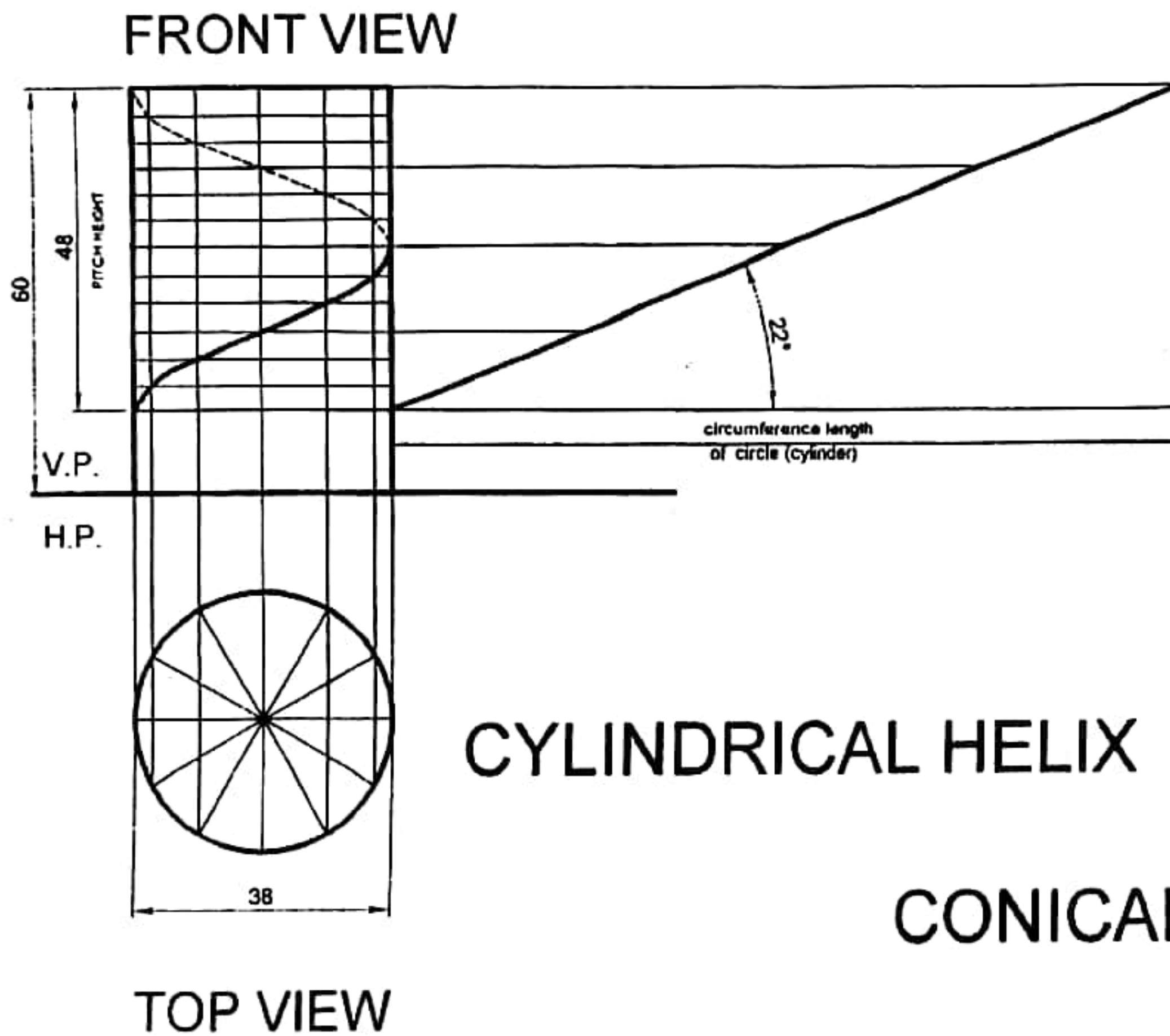

CYLINDRICAL HELIX

CONICAL HELIX

IA HELIX IS A LOCUS OF A POINT 'P' WHICH MOVES AROUND THE CIRCUMFERENCE OF A RIGHT CYLINDER, AT THE SAME TIME MOVING AXIALLY ALONG IT, IN SUCH WAY THAT RATIO OF ITS CIRCUMFERENTIAL AND AXIAL MOVEMENT IS CONSTANT.

	SUBJECT	TOPIC	DRAWN BY	CHECKED BY	DATE	SCALE
	ENGINEERING DRAWING	CURVES HELICES CYLINDRICAL AND CONICAL HELIX	NAME ROLL NO	DATE	DRAWING NO	GC/CC-3

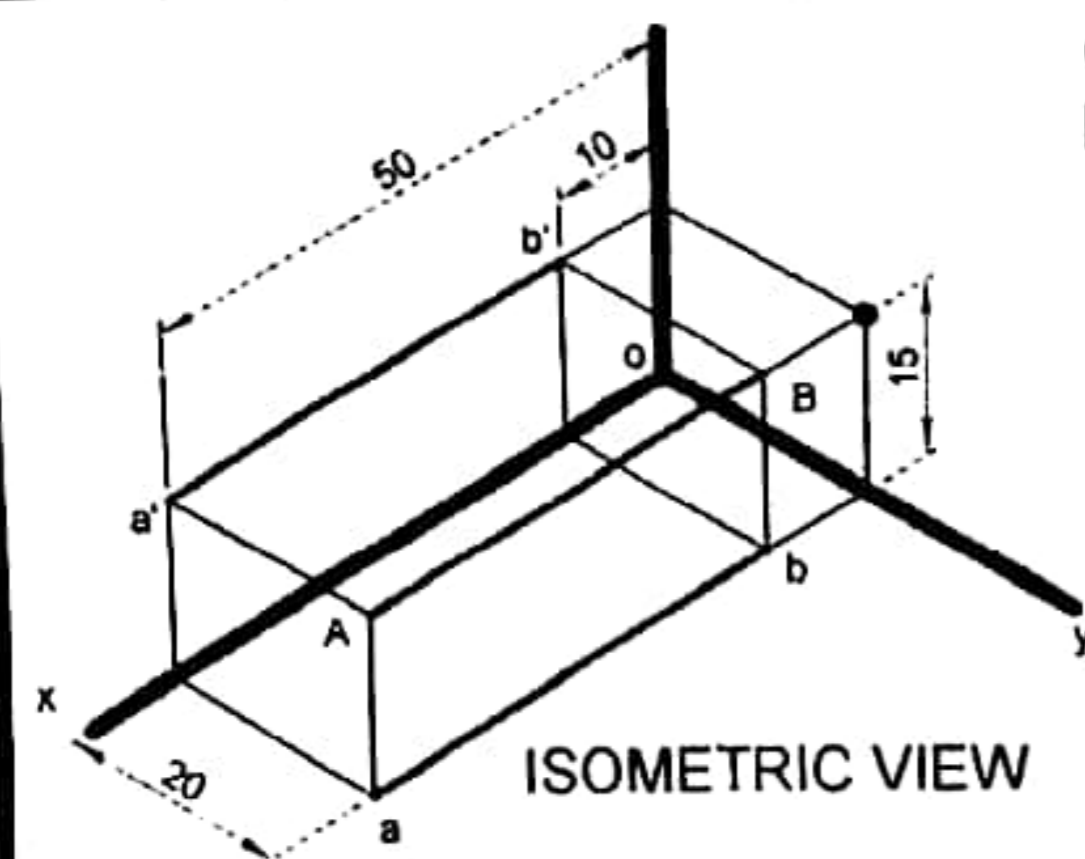

ORTHOGRAPHIC PROJECTION

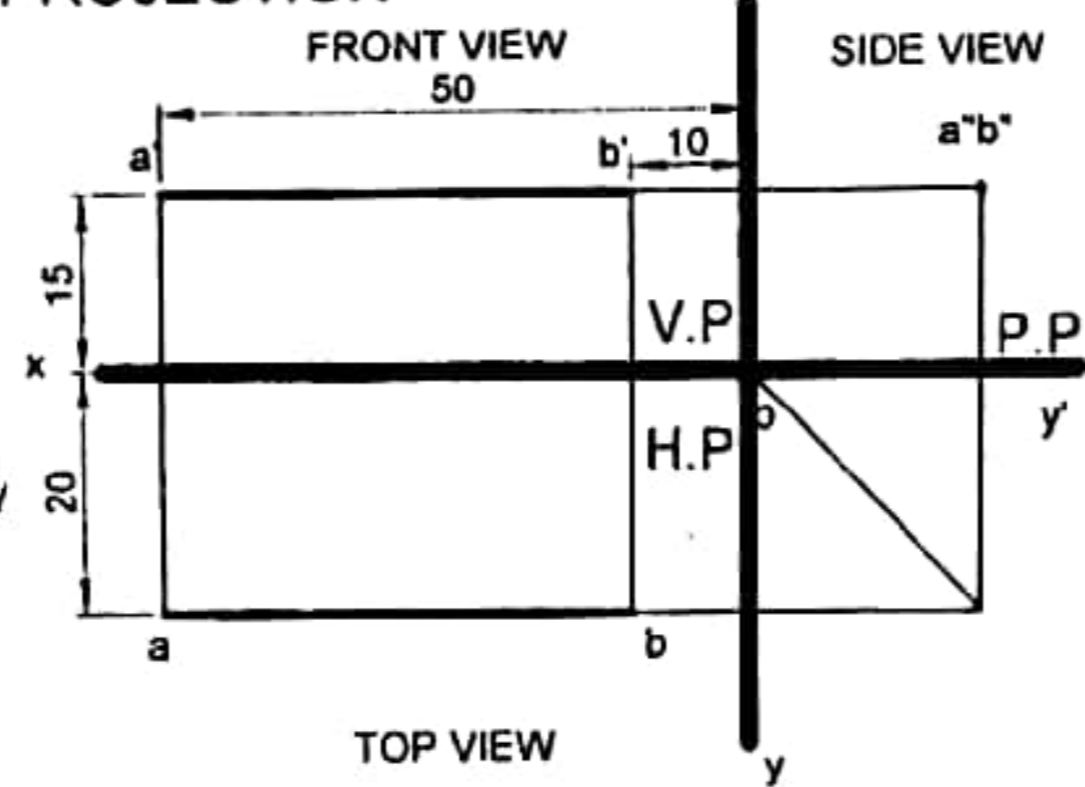

THIS LINE IS PARALLEL TO HP AND VP PERPENDICULAR TO PP

Draw three plane projection of a line AB, whose co-ordinate of the end points are as given in table, and also mention the position of line to principal plane.

	A	B
x	50	10
y	20	20
z	15	15

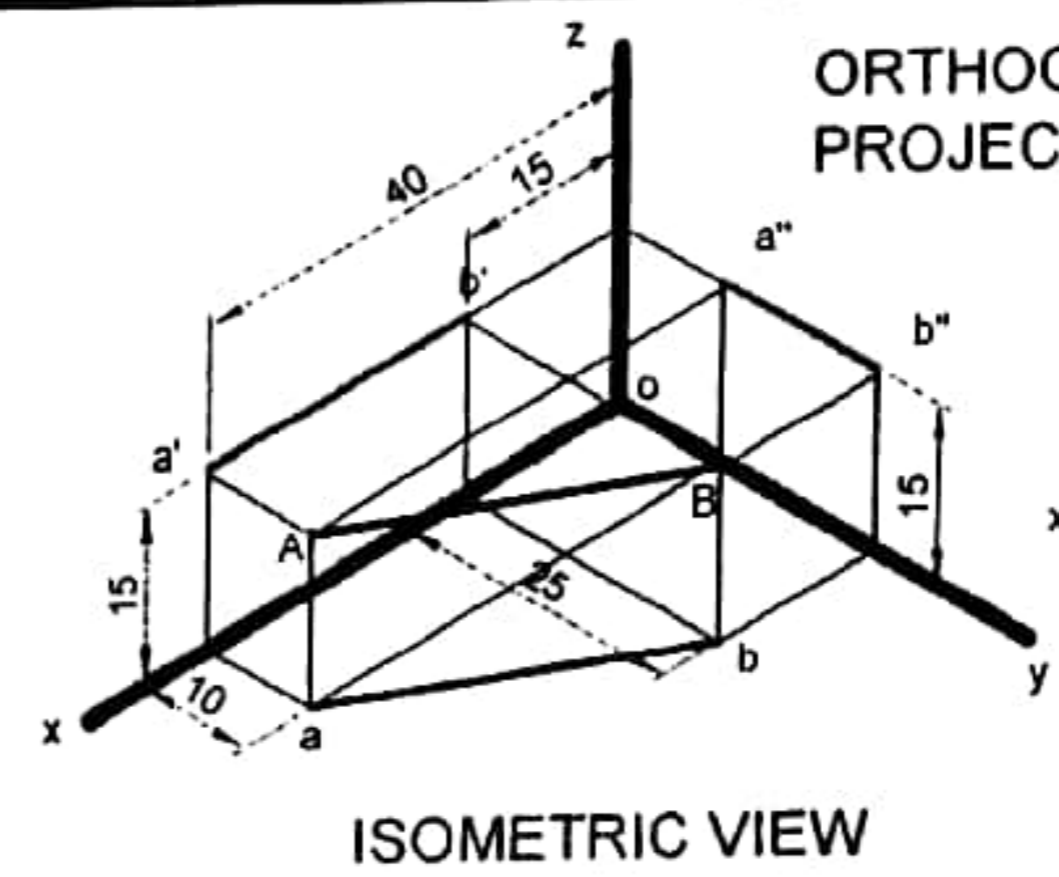

ORTHOGRAPHIC PROJECTION

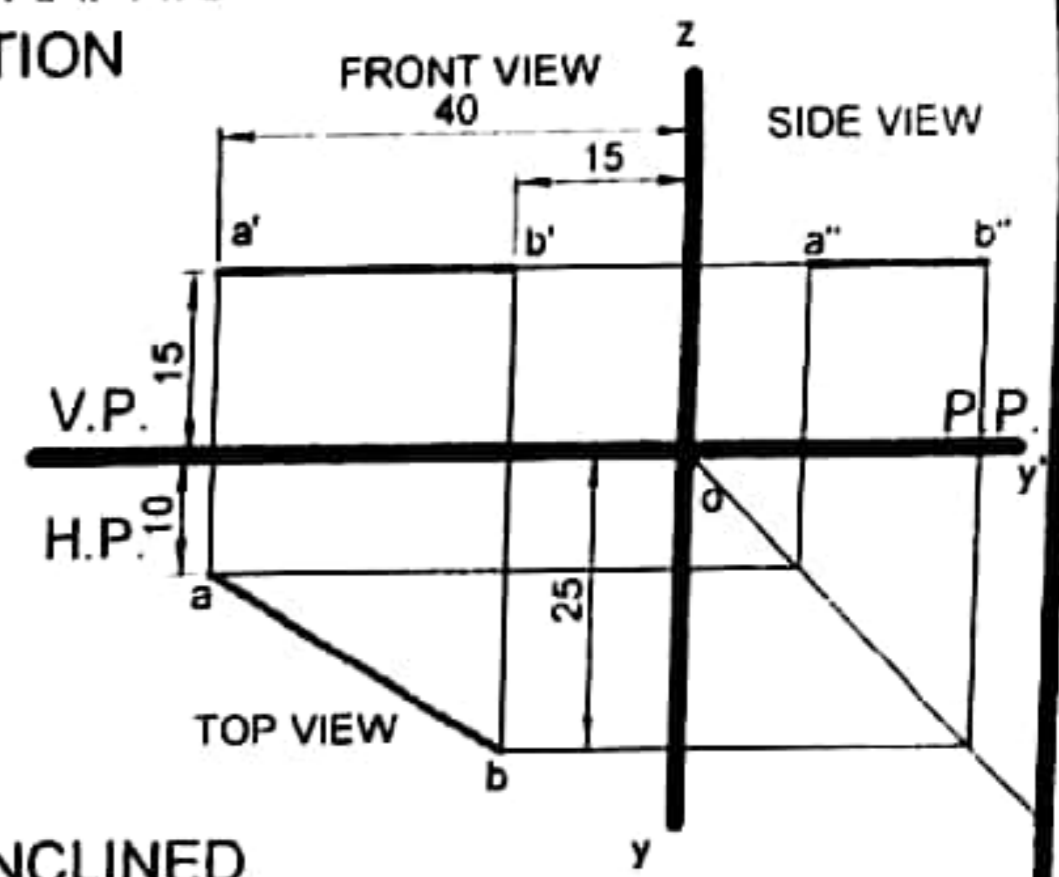

THIS LINE IS PARALLEL TO HP AND INCLINED TO VP AND PP

Draw three plane projection of a line AB, whose co-ordinate of the end points are as given in table, and also mention the position of line to principal plane.

	A	B
x	40	15
y	10	25
z	15	15

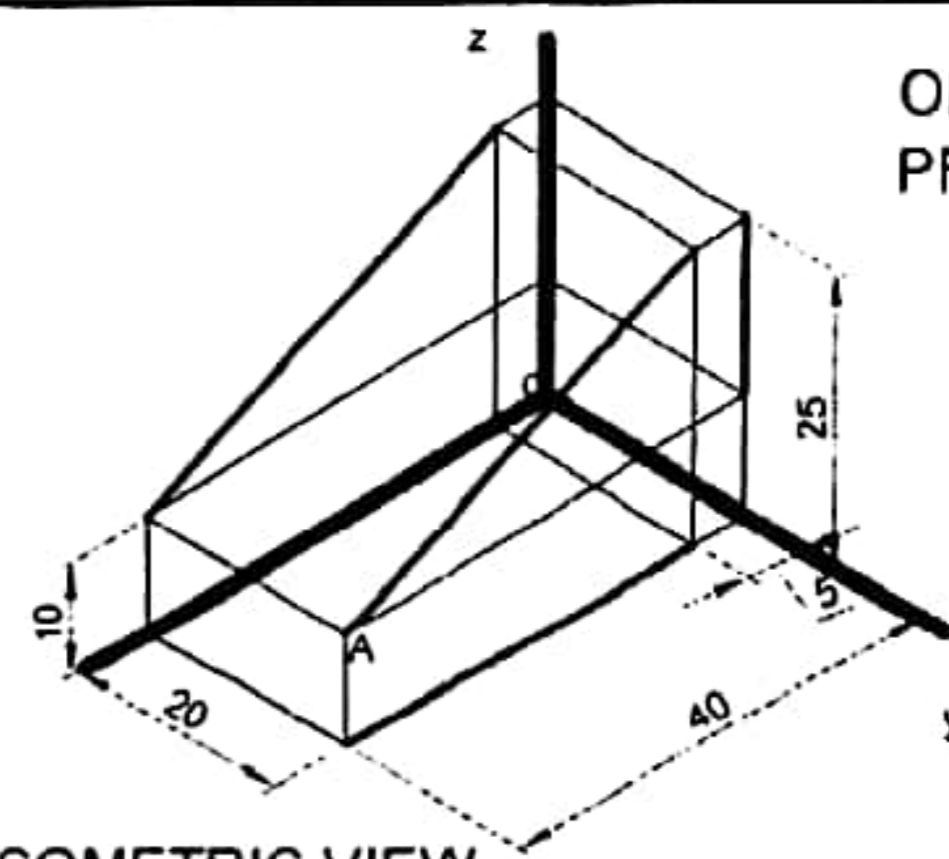

ORTHOGRAPHIC PROJECTION

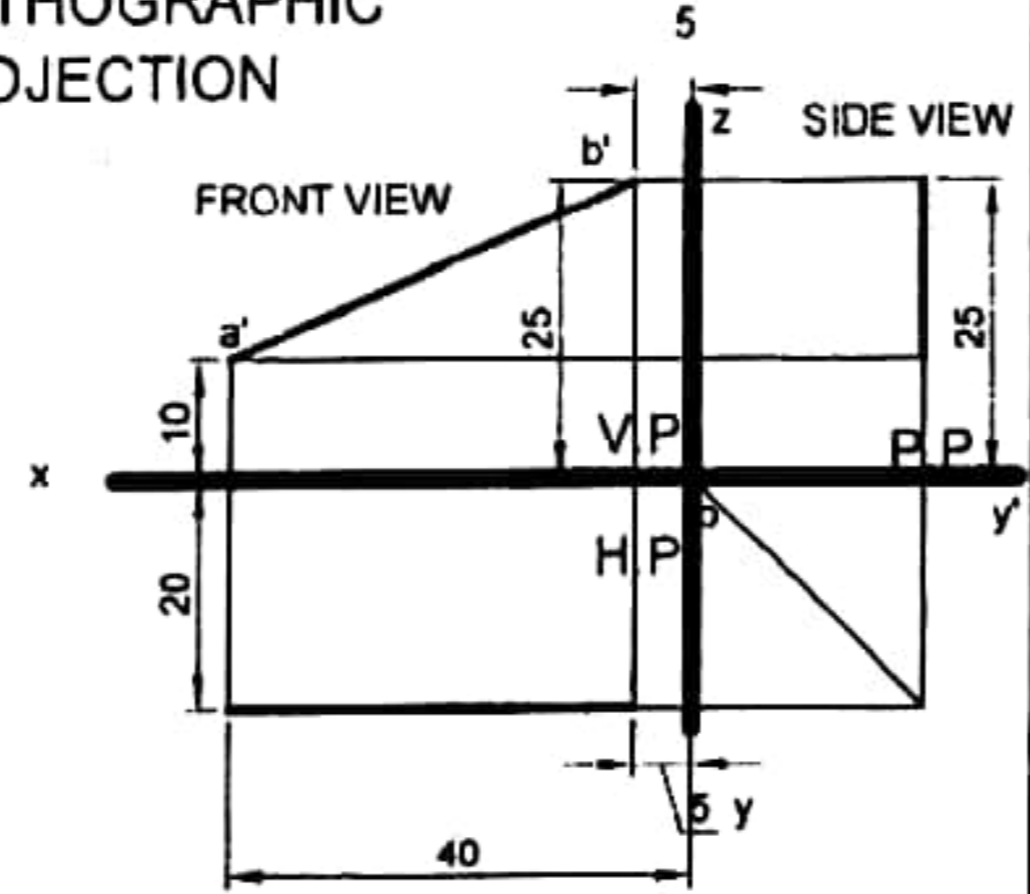

THIS LINE IS PARALLEL TO VP AND INCLINED TO HP AND PP

Draw three plane projection of a line AB, whose co-ordinate of the end points are as given in table, and also mention the position of line to principal plane.

	A	B
x	40	5
y	20	20
z	10	25

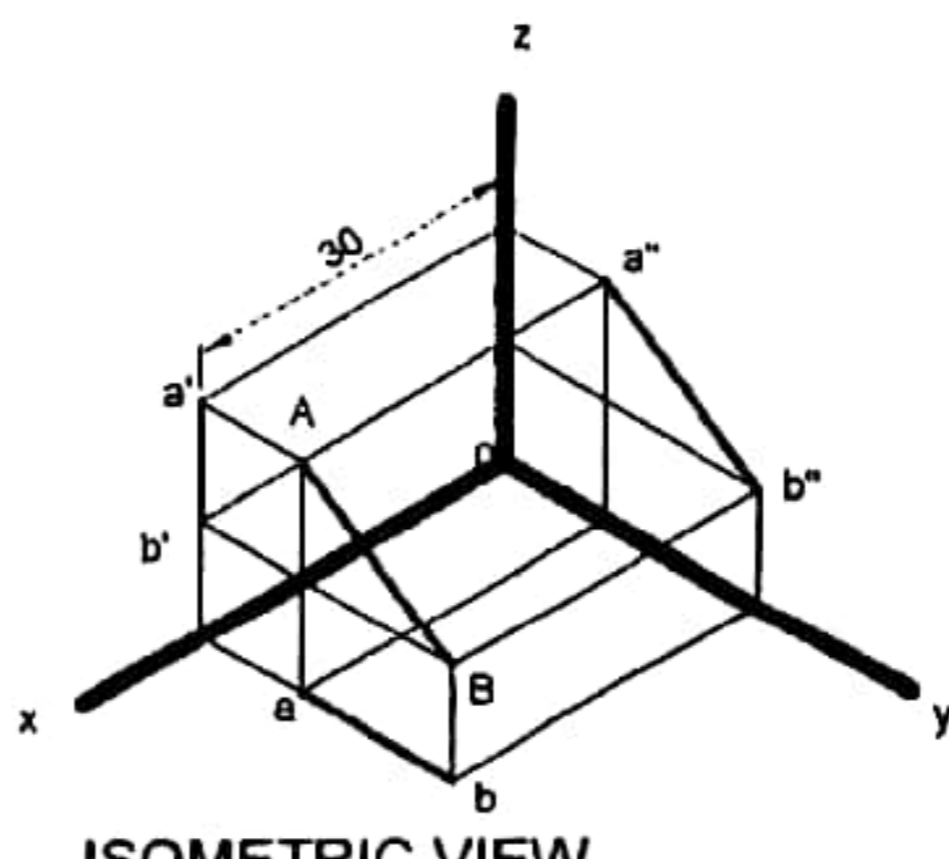

ORTHOGRAPHIC PROJECTION

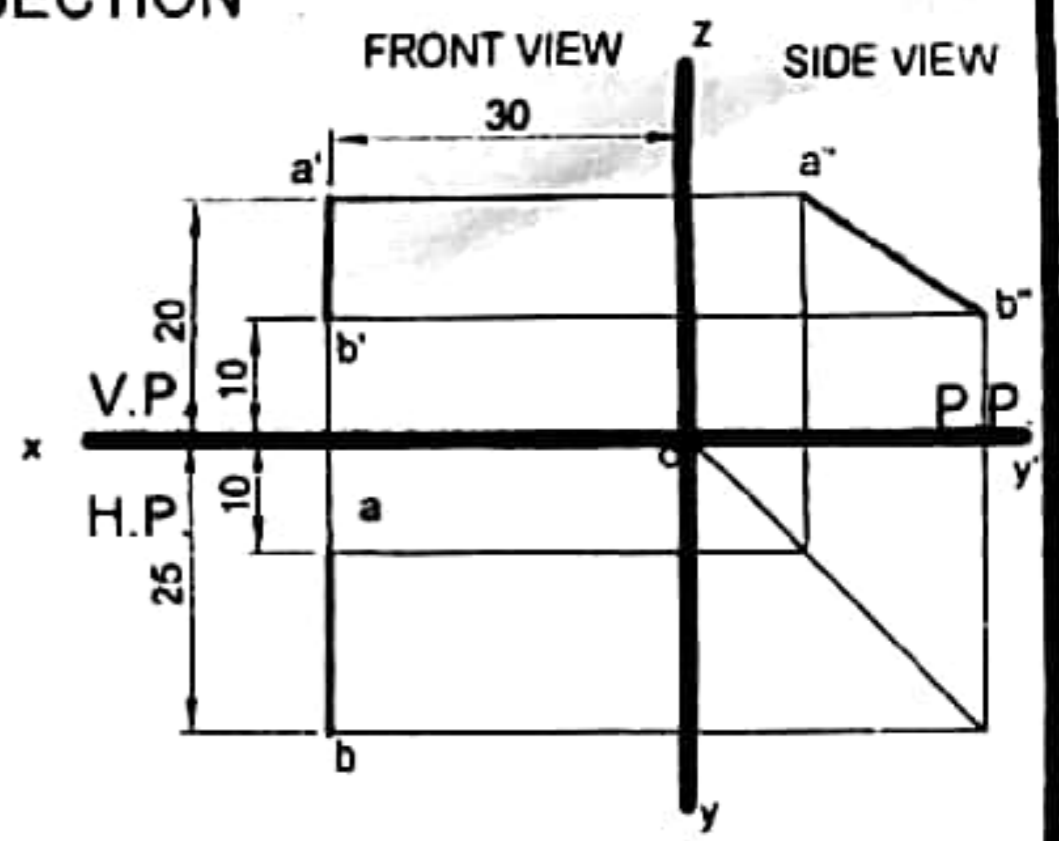

THIS LINE IS PARALLEL TO PP AND INCLINED TO HP AND VP

Draw three plane projection of a line AB, whose co-ordinate of the end points are as given in table, and also mention the position of line to principal plane.

	A	B
x	30	30
y	10	25
z	25	10

SUBJECT ENGINEERING DRAWING	TOPIC ORTHOGRAPHIC PROJECTION DESCRIPTIVE GEOMETRY POINT AND LINES PROJECTION	DRAWN BY	CHECKED BY	DATE	SCALE
		NAME	DATE	DRAWING NO	DG- 1
		ROLL NO			

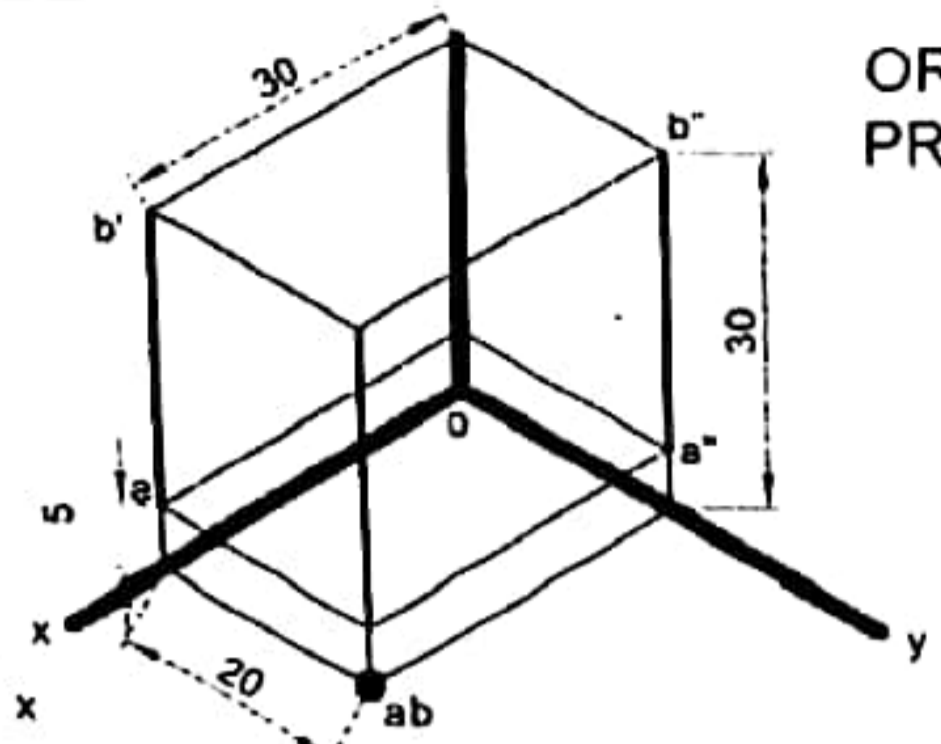

ISOMETRIC VIEW

THIS LINE IS PARALLEL TO VP AND PP AND PERPENDICULAR TO HP.

Draw three plane projection of a line AB, whose co-ordinate of the end points are as given in table, and also mention the position of line to principal plane.

	A	B
x	30	30
y	20	20
z	5	30

ORTHOGRAPHIC PROJECTION

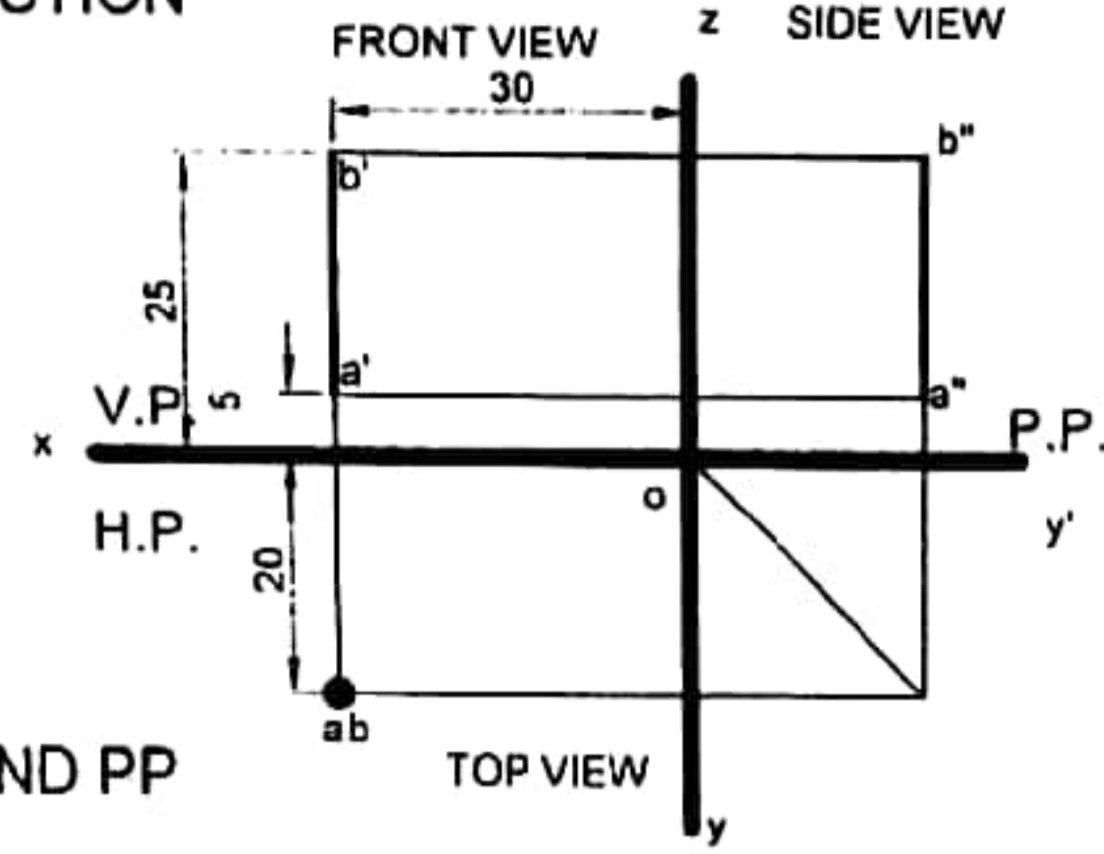

A line AB is 50mm long line is parallel to HP and to VP. The end A is 15mm above the HP and 10mm in front of VP. Draw the projection of line.

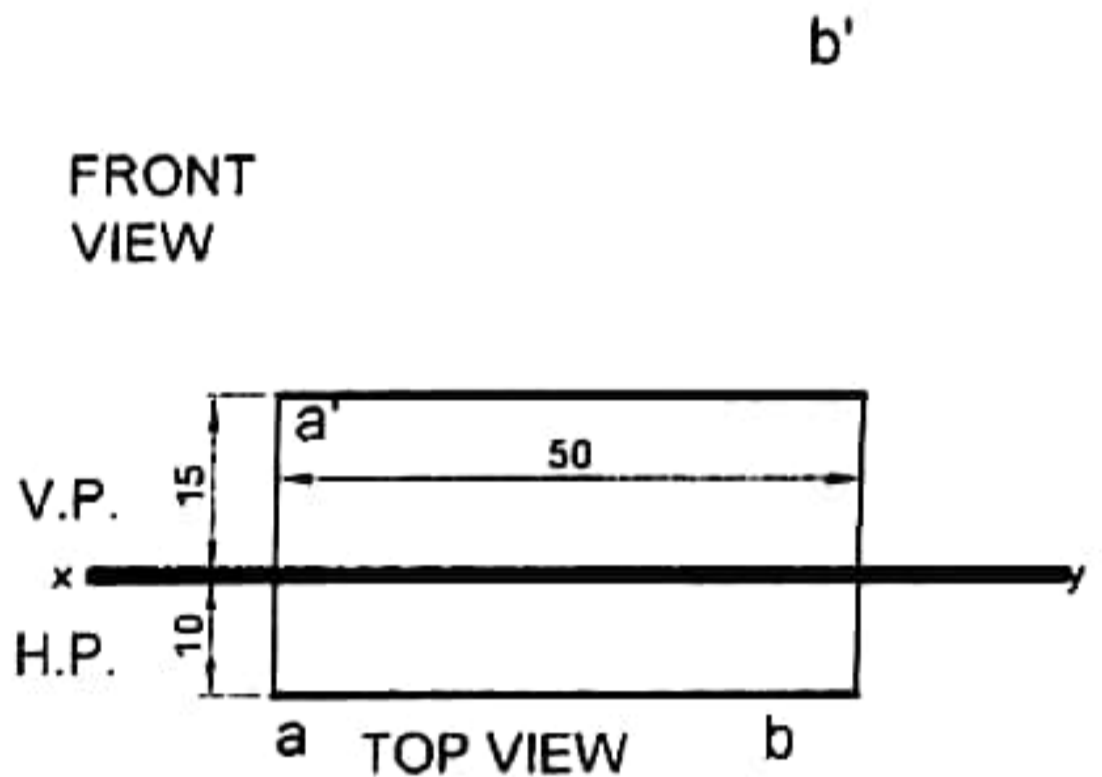

ORTHOGRAPHIC PROJECTION

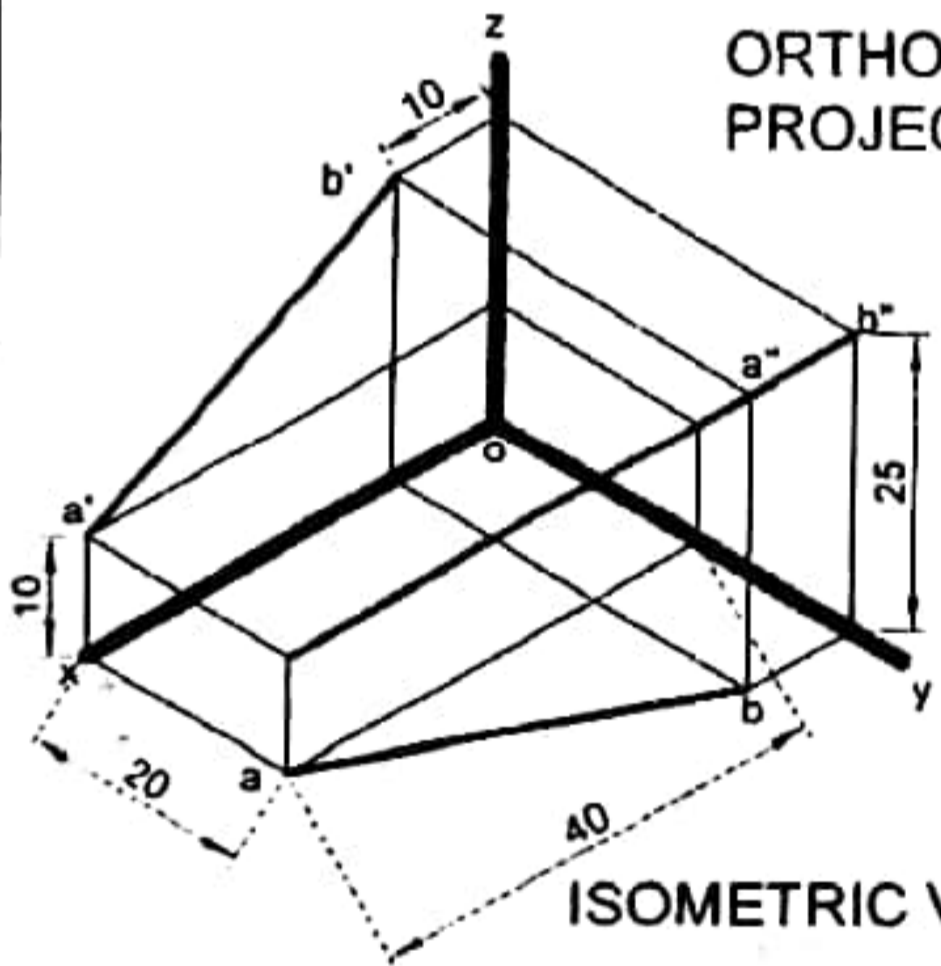

ISOMETRIC VIEW

THIS LINE IS IS INCLINED TO HP, VP AND PP. (THIS LINE CALLED OBLIQUE LINE.) or INCLINED TO ALL PRINCIPAL PLANE.

	A	B
x	40	10
y	20	35
z	10	25

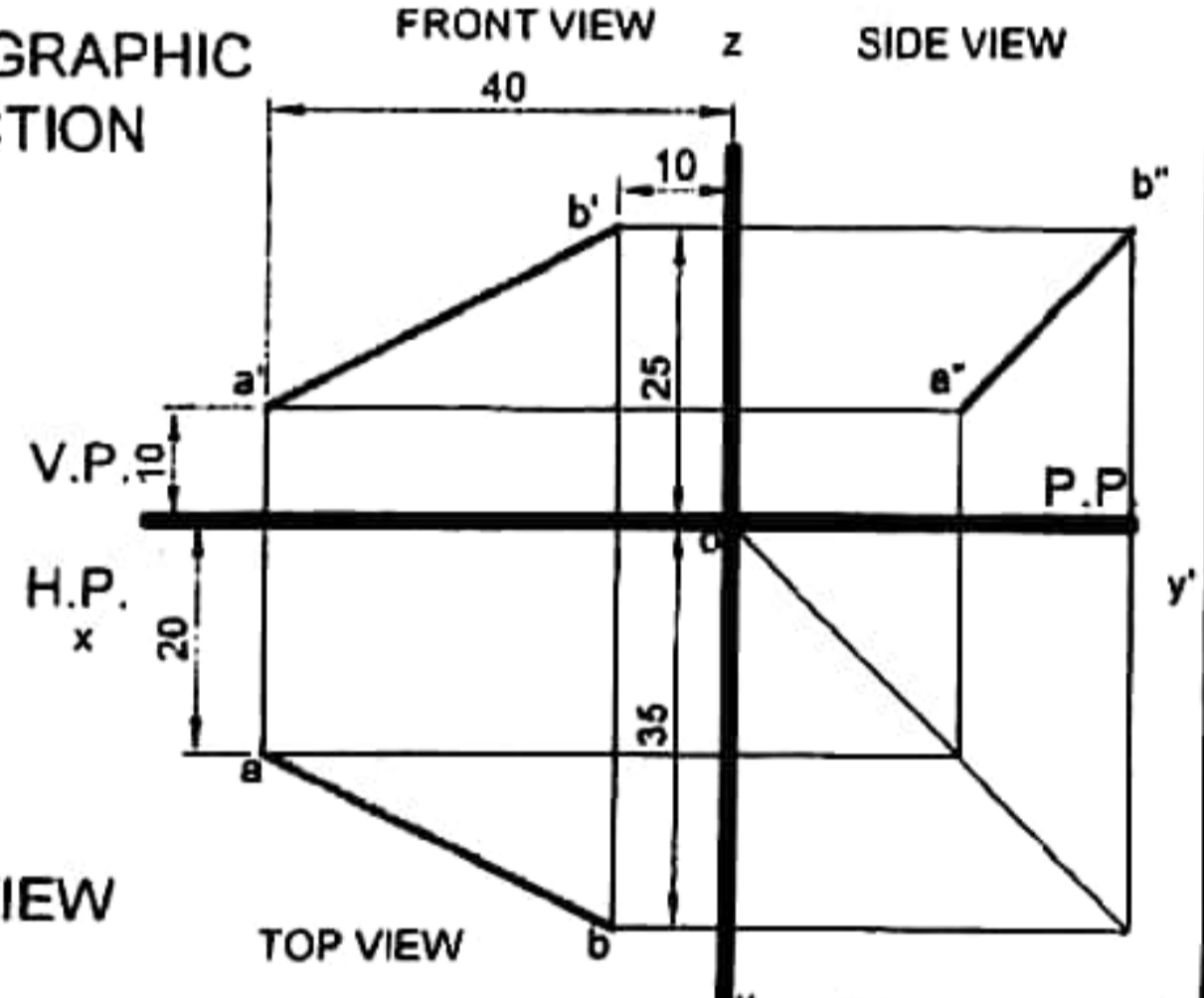

A line AB is 50mm long line is parallel to VP and inclined to HP at 30°. The end A is 15mm above the HP and 10mm in front of VP. draw the projection of line.

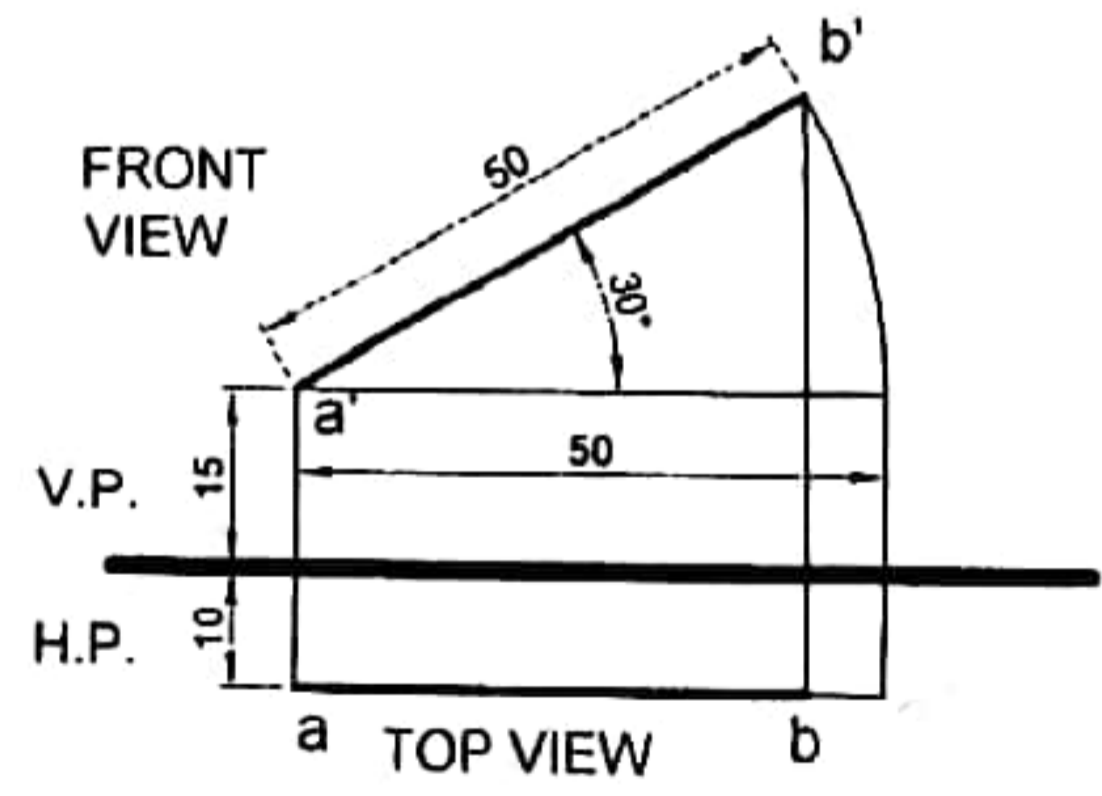

SUBJECT
ENGINEERING DRAWING

TOPIC
ORTHOGRAPHIC PROJECTION
POINT AND LINES PROJECTION

DRAWN BY
NAME
ROLL NO

CHECKED BY
DATE

DATE

SCALE

DRAWING NO
DG-2

A line AB is 60mm long line is parallel to HP and inclined to VP at 30°. The end A is 12mm above the HP and 15mm in front of VP. draw the projection of line.

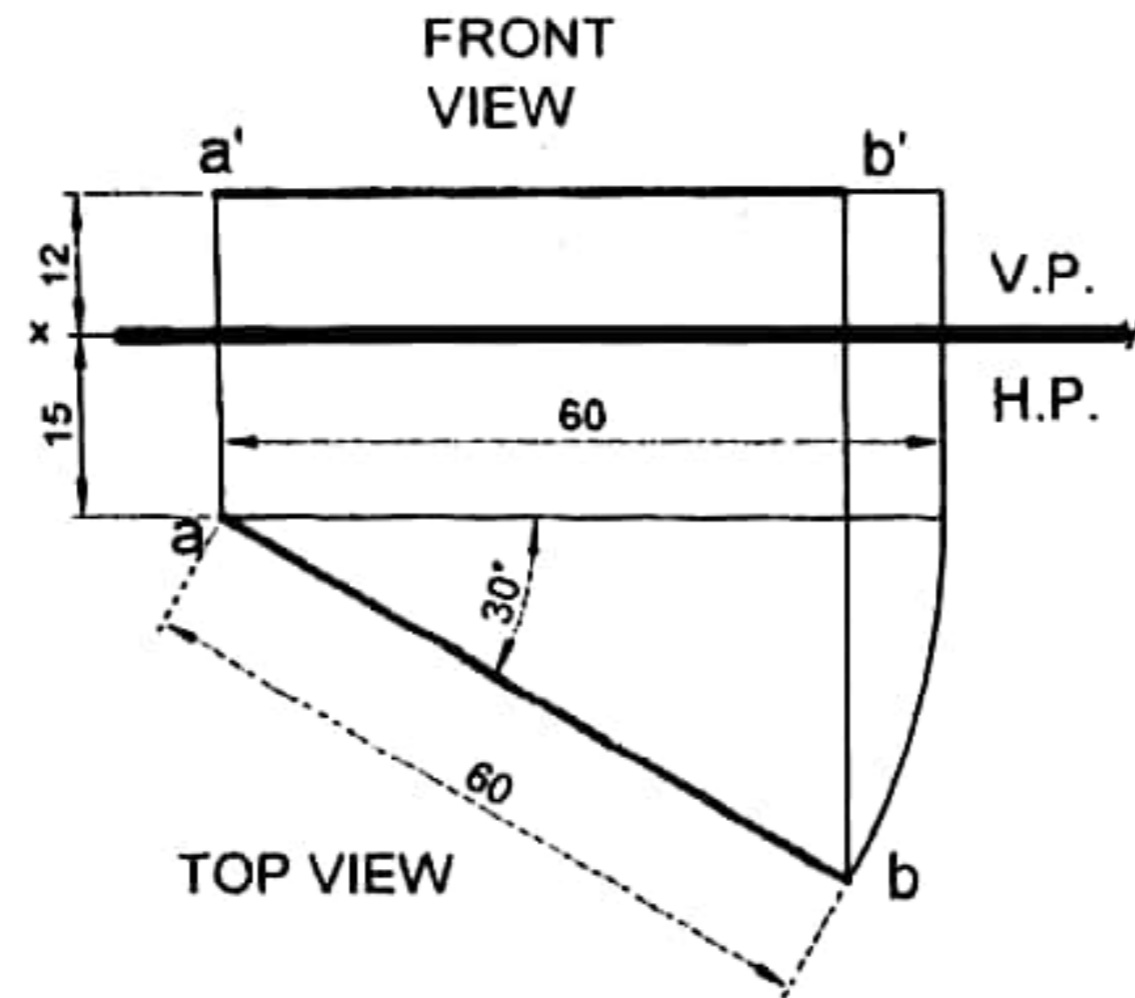

DRAW THE PROJECTION OF LINE AB WHEN END A IS 15 MM FROM HP AND 20MM FROM VP AND END B IS 25MM FROM HP AND 35MM FROM VP. ,AND PROJECTOR ARE 45 MM APART.

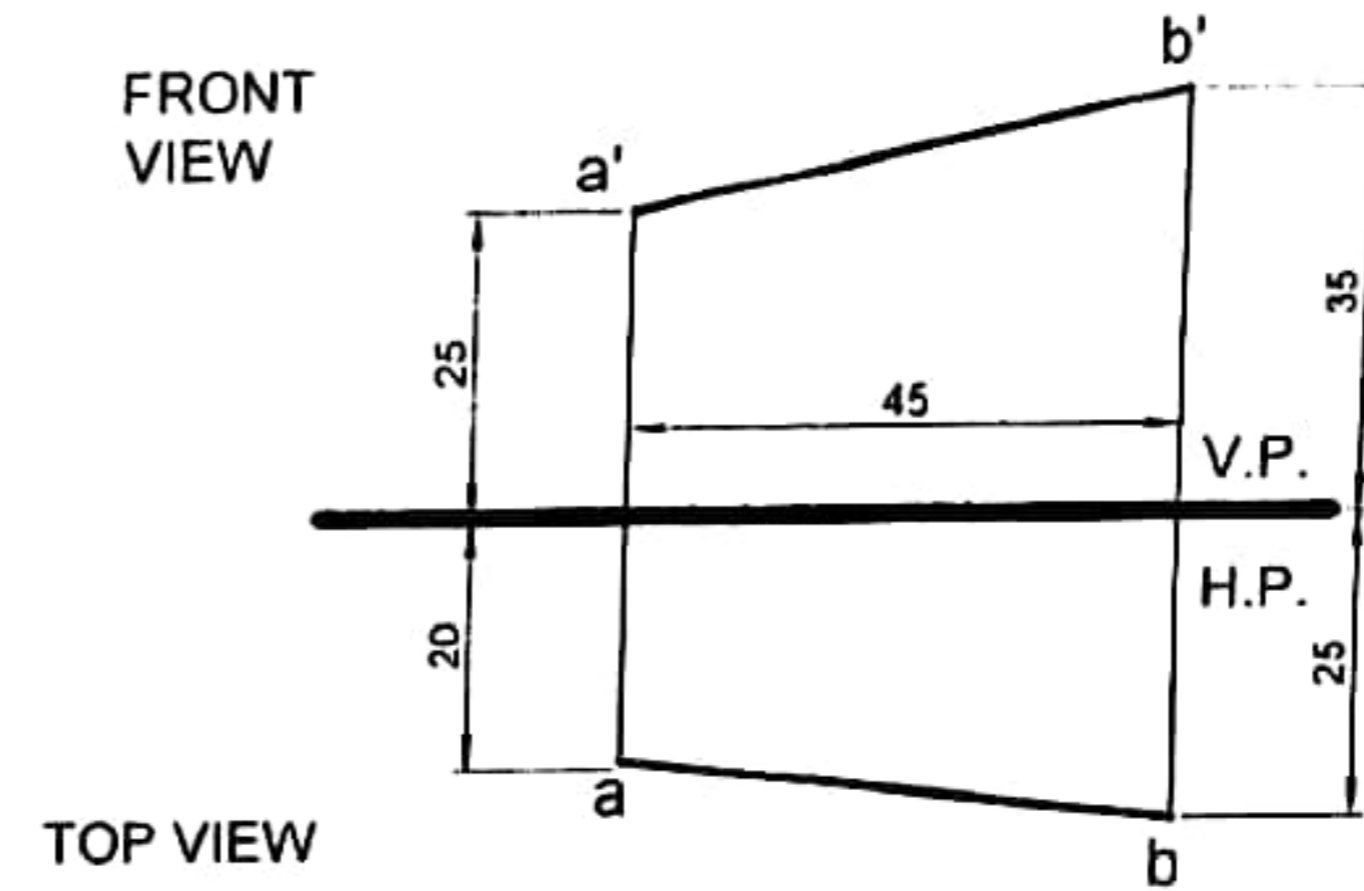

A LINE OF 90 MM LONG IS PARALLEL TO AND 25MM IN FRONT OF VP. ITS ONE END IS IN THE HP AND OTHER END IS 50MM ABOVE HP DRAW ITS PROJECTION AND FIND INCLINATION WITH HP.

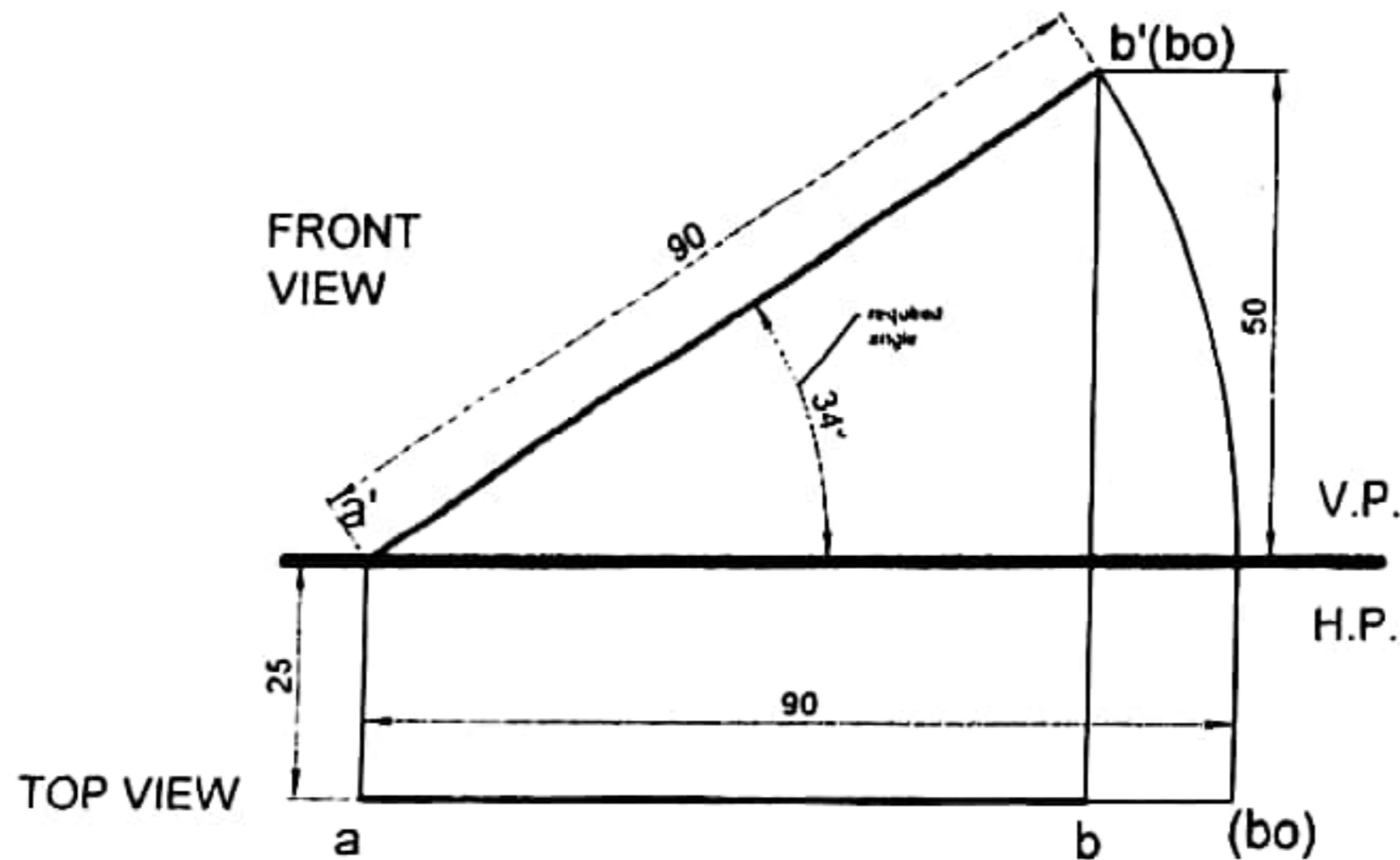

A LINE OF 60 MM LONG IS CONTAINED AT HP AND INCLINED TO VP AT 30°, ONE POINT OF THIS LINE IS 10 MM FROM VP. DRAW ITS PROJECTION.

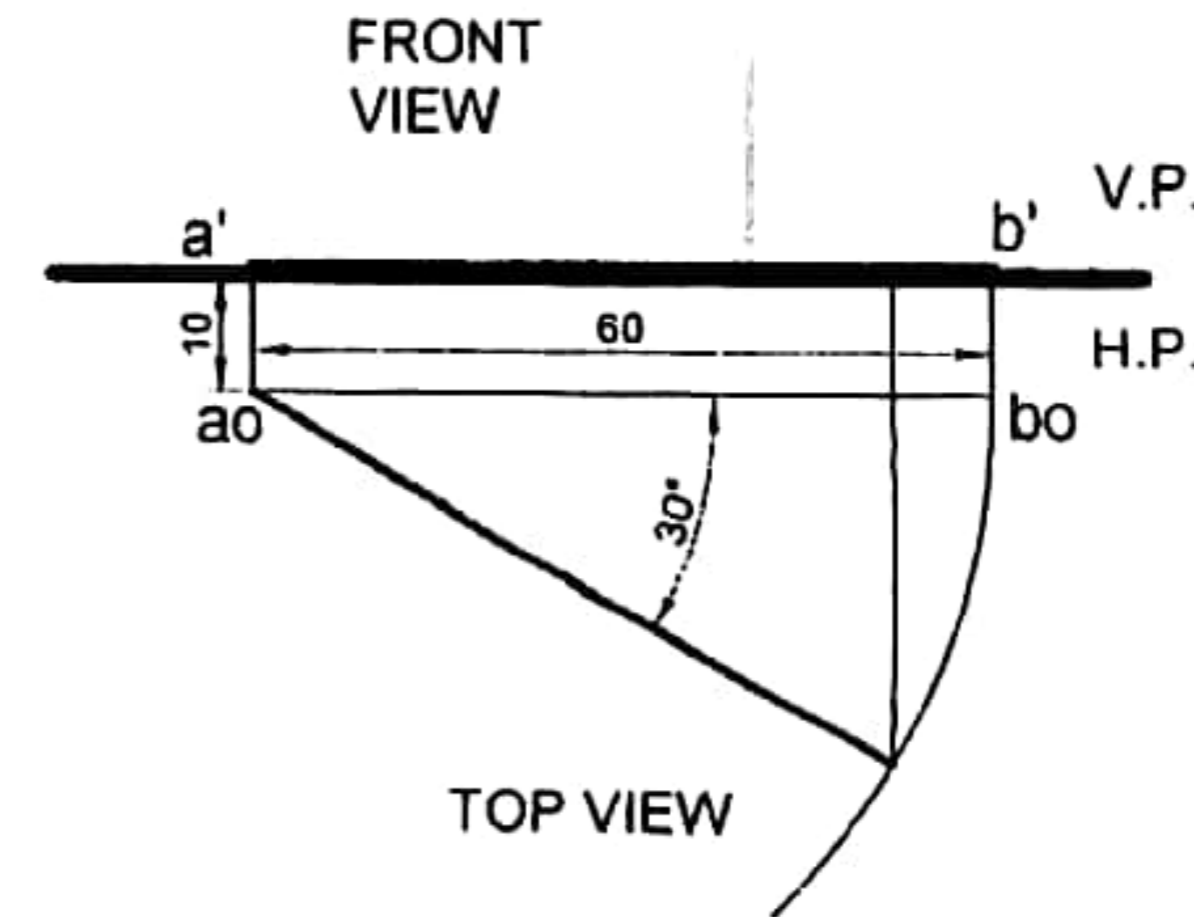

SUBJECT ENGINEERING DRAWING	TOPIC ORTHOGRAPHIC PROJECTION LINE PROJECTION	DRAWN BY NAME ROLL NO	CHECKED BY	DATE	SCALE
				DATE	DRAWING NO DG-3

A LINE AB IS 60MM LONG IS INCLINED TO HP AT 30° AND 45° TO VP ITS ONE END IS ON HP AND 15MM IN FRONT OF VP, DRAW ITS PROJECTION.

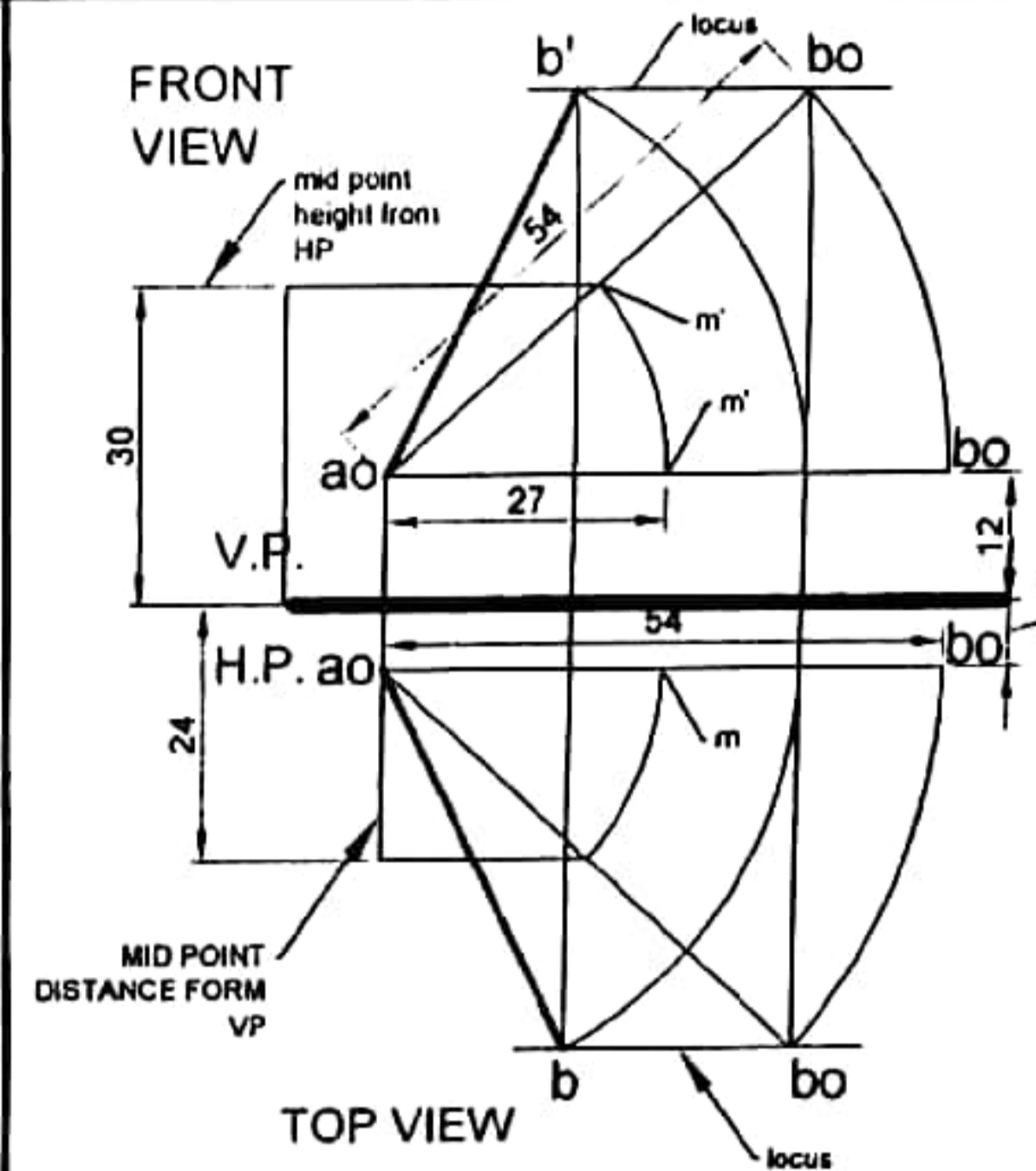
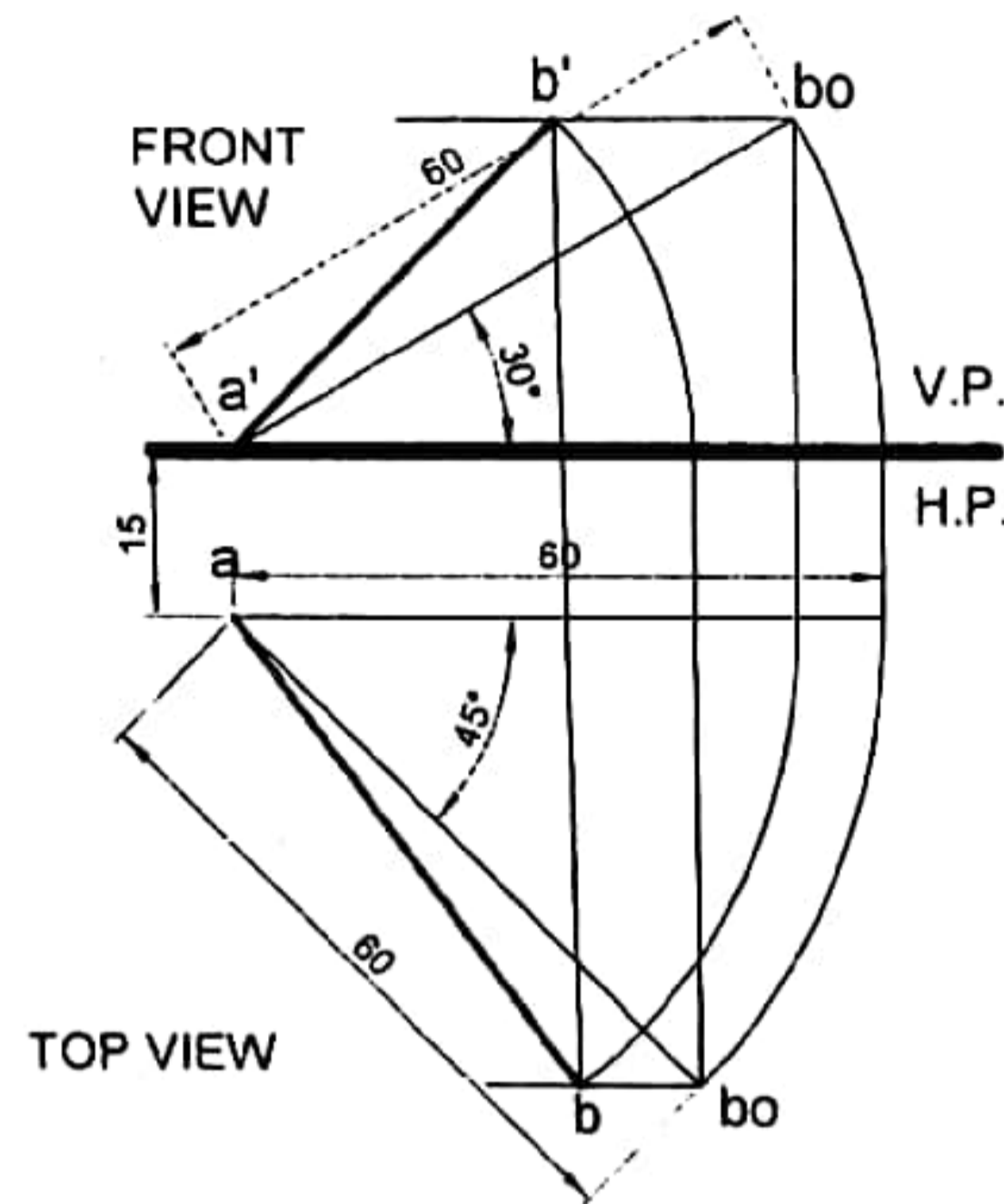

A LINE AB IS 54 MM LONG WHICH MID POINT M IS 30MM FROM HP AND 24 MM FROM VP, POINT A IS 12 MM ABOVE THE HP AND 6MM IN FRONT OF VP, DRAW ITS PROJECTION.

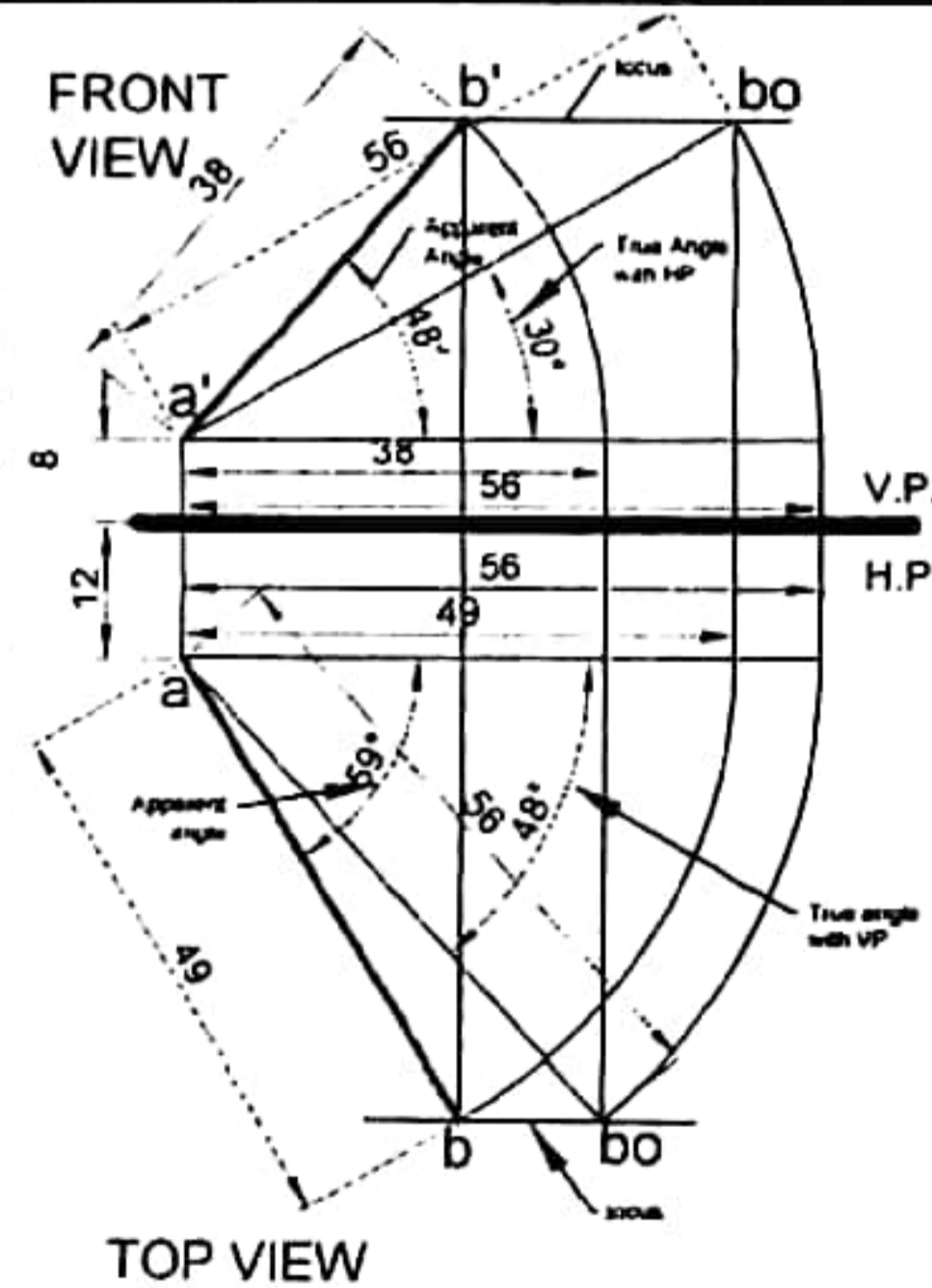

A LINE AB OF 56 MM LONG IS 49 MM IN TOP VIEW AND 38 MM IN FRONT VIEW, WHILE THE ONE POINT 'A' IS 8 MM ABOVE THE HP, AND 12 MM IN FRONT OF VP. DRAW THE PROJECTION OF LINE FINDING THE INCLINATION WITH HP AND VP.

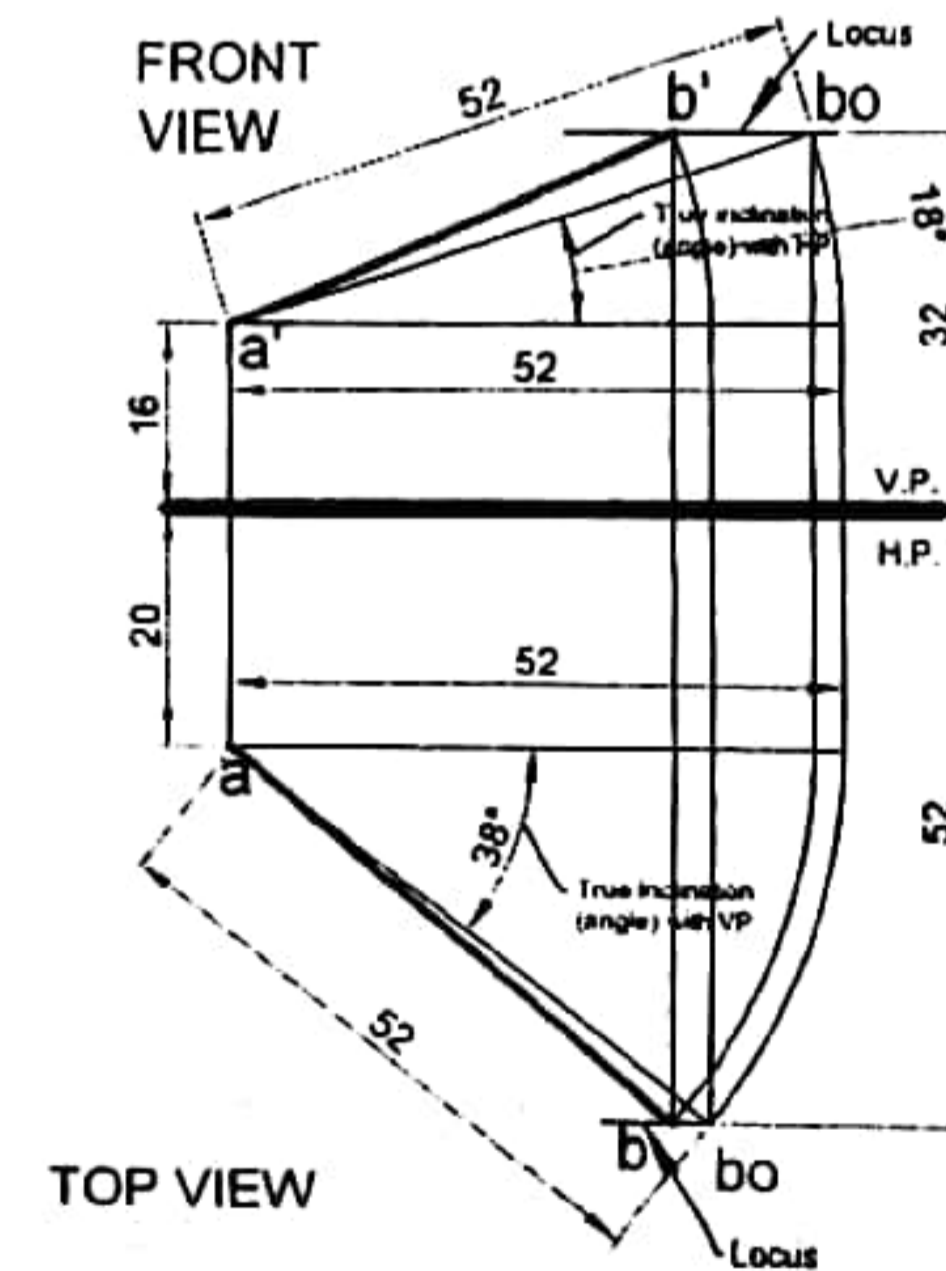

A LINE AB OF 52 MM LONG HAS ITS ONE 'A' IS 16 MM ABOVE THE HP, AND 20 MM IN FRONT OF VP, THE OTHER END IS 32 MM ABOVE THE HP AND 52 MM IN FRONT OF VP, DRAW THE PROJECTION OF LINE FINDING THE INCLINATION (ANGLE) WITH HP AND VP.

SUBJECT ENGINEERING DRAWING	TOPIC ORTHOGRAPHIC PROJECTION PROJECTION OF OBLIQUE LINE	DRAWN BY NAME ROLL NO	CHECKED BY	DATE	SCALE
				DATE	DRAWING NO DG-4

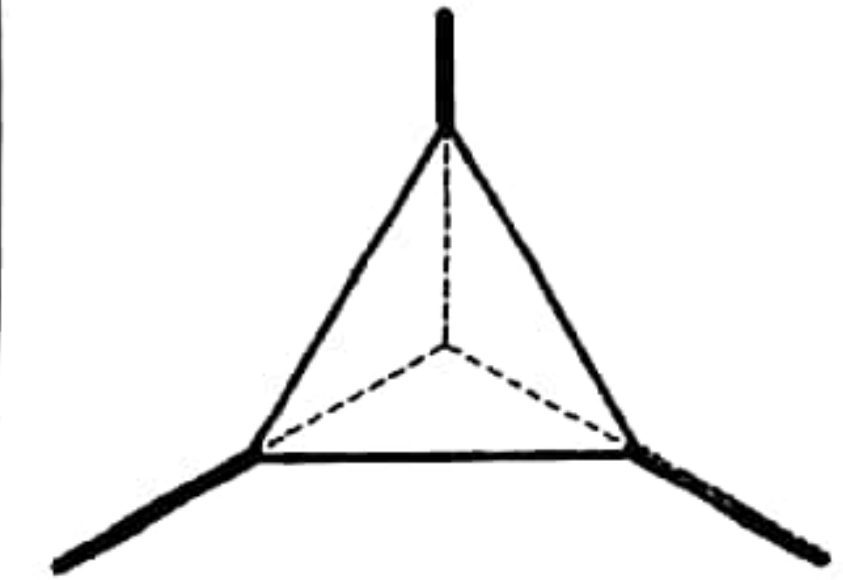
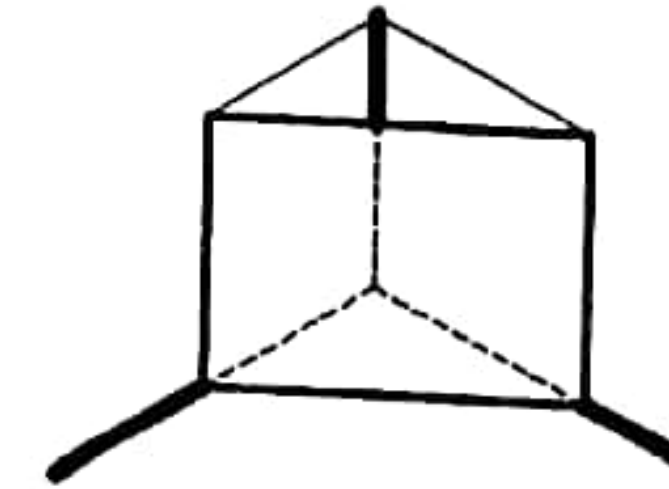
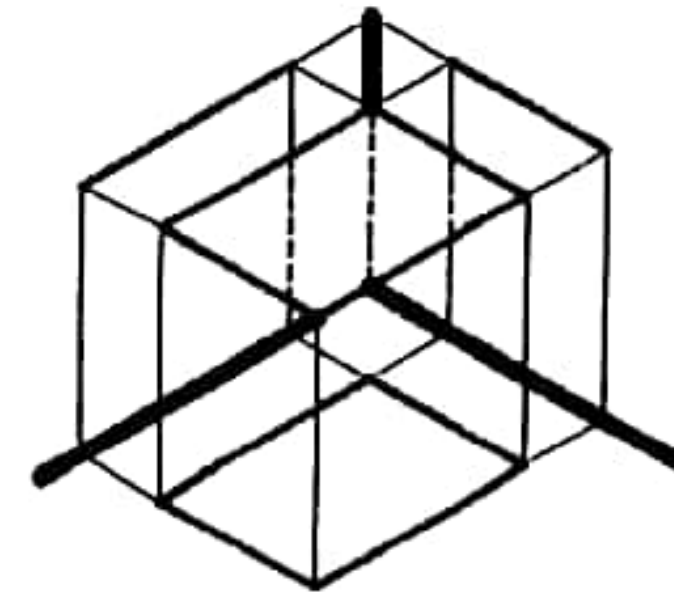
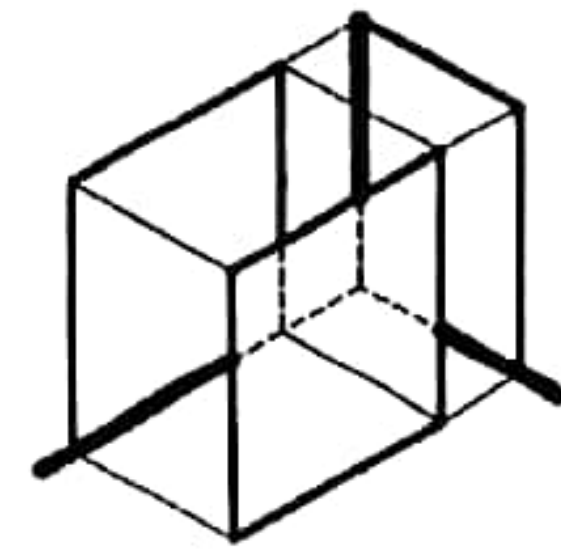
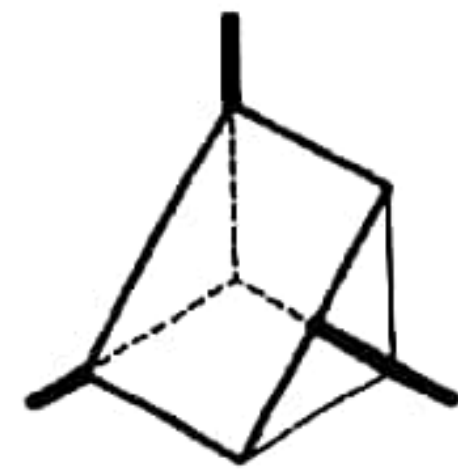

THE PLANE WHICH IS INCLINED TO HP, PP AND PERPENDICULAR TO VP.

THE PLANE WHICH IS PARALLEL TO VP AND PERPENDICULAR TO HP AND PP.

THE PLANE WHICH IS PARALLEL TO HP AND PERPENDICULAR TO VP AND PP.

THE PLANE WHICH IS PERPENDICULAR TO HP AND INCLINED TO VP AND PP.

THE PLANE WHICH IS INCLINED TO HP, VP AND PP.(OBLIQUE PLANE)

VERTICAL PROJECTING PLANE

PROFILE OR HORIZONTAL PROJECTING PLANE

PROFILE OR VERTICAL PROJECTING PLANE

HORIZONTAL PROJECTING PLANE

OBLIQUE PLANE

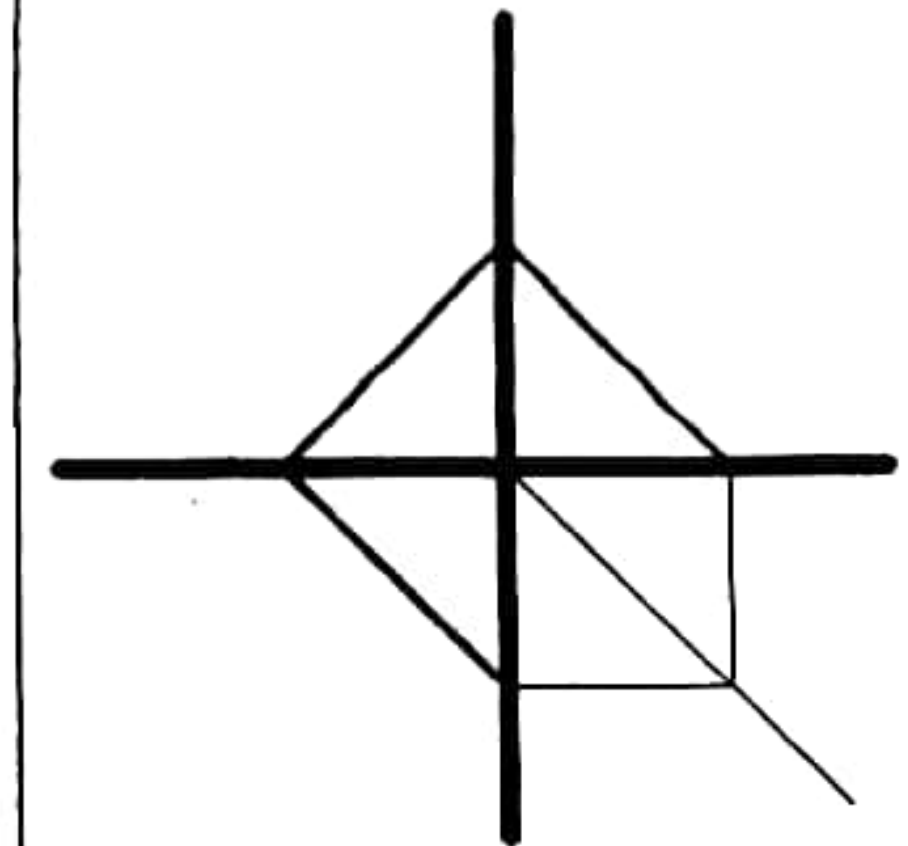
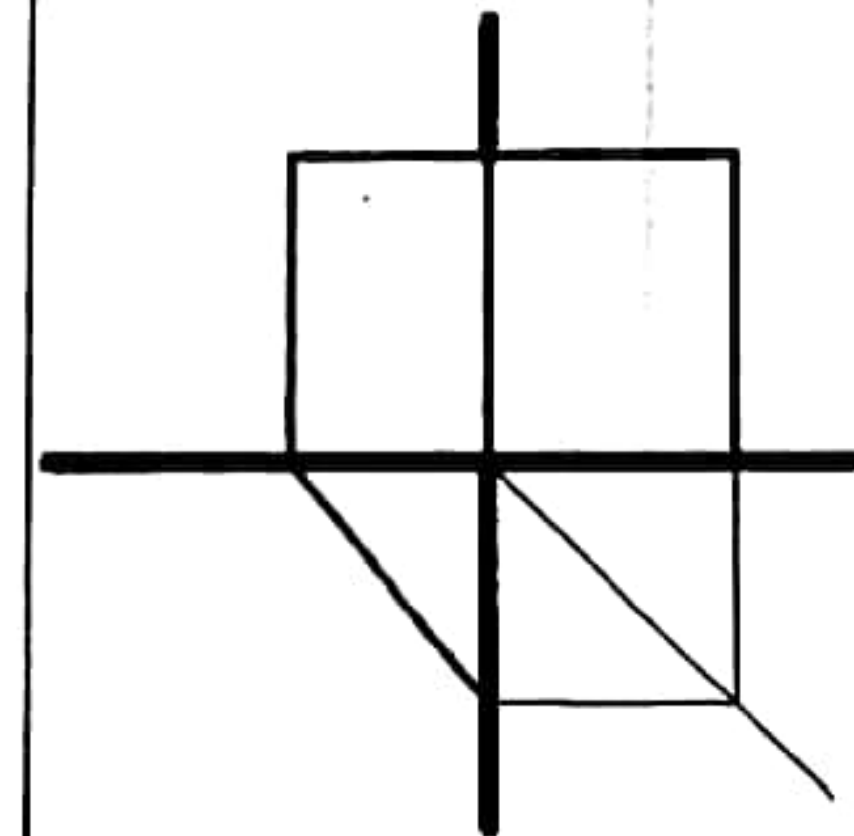
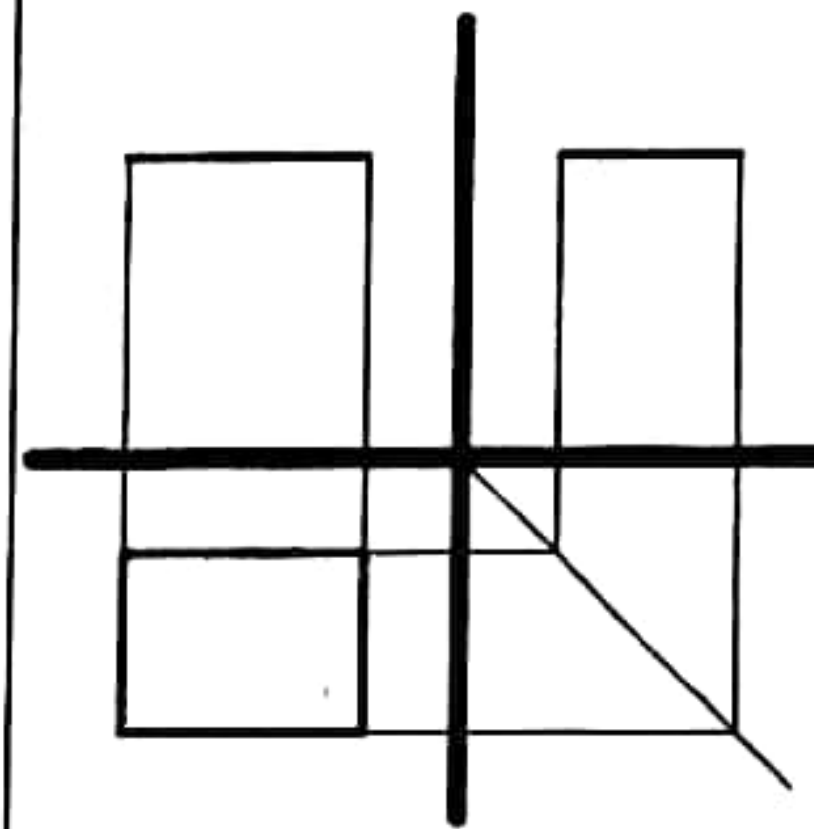
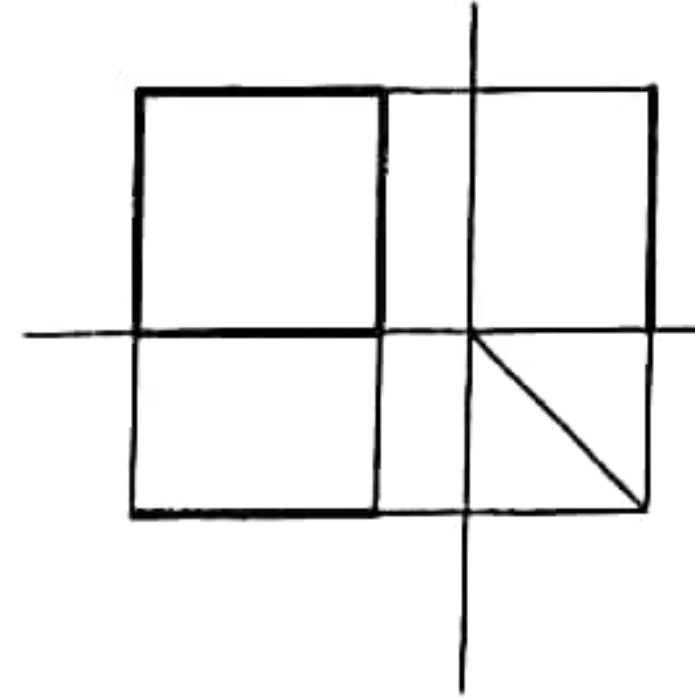
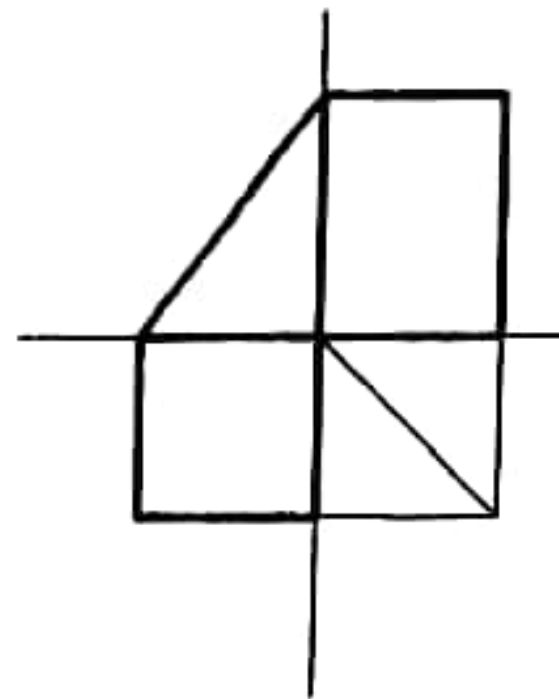

THE ORTHOGRAPHIC PROJECTIONS OF ABOVE MENTIONS PLANES.

SUBJECT

ENGINEERING DRAWING

TOPIC

ORTHOGRAPHIC PROJECTION
PROJECTION OF PLANES

DRAWN BY

NAME
ROLL NO

CHECKED BY

DATE

DATE

SCALE

DRAWING NO

DG-5

A square plane of 35mm sides is inclined to HP at 30°, one side of square is in HP and 20 mm in front of VP. Draw the projection.

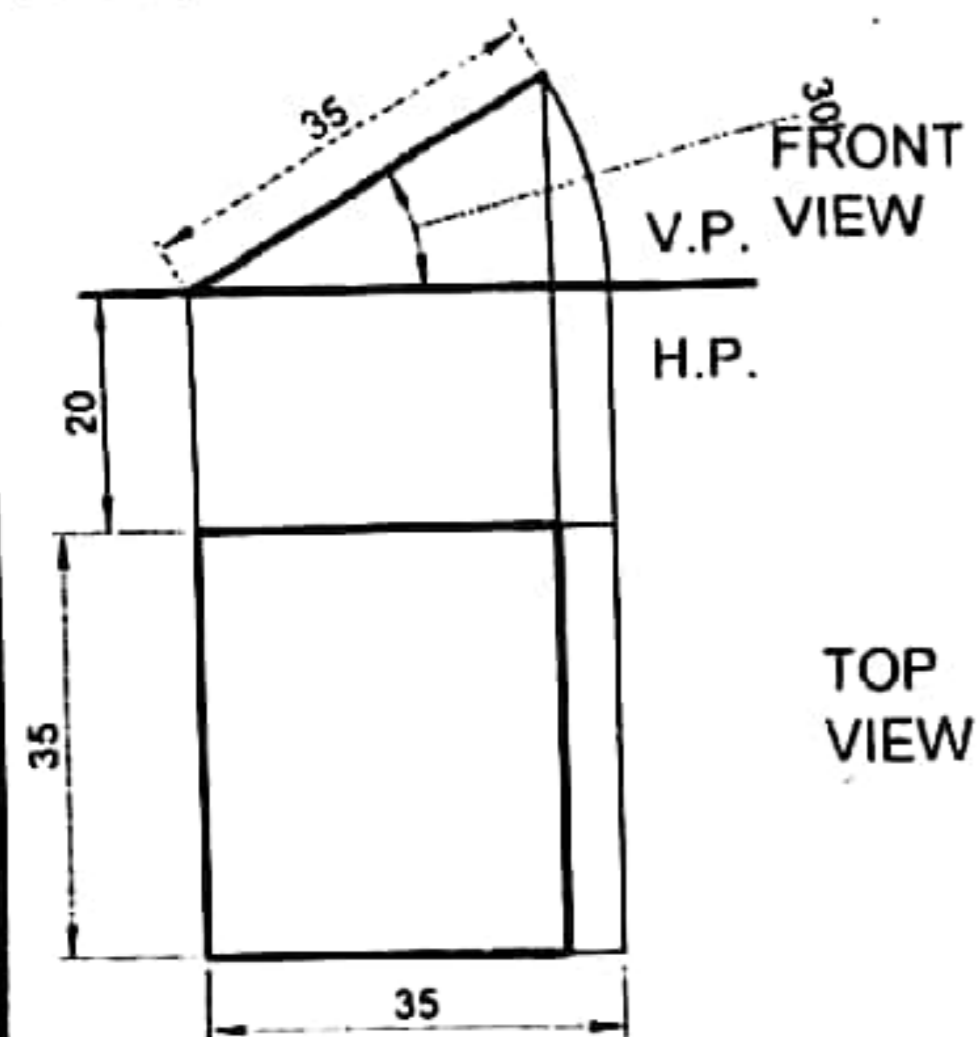

A rectangular plane of 40x25mm is parallel to HP. One of the nearest side and corner is 30° to VP, 15mm in front respectively, and 10mm above the HP.

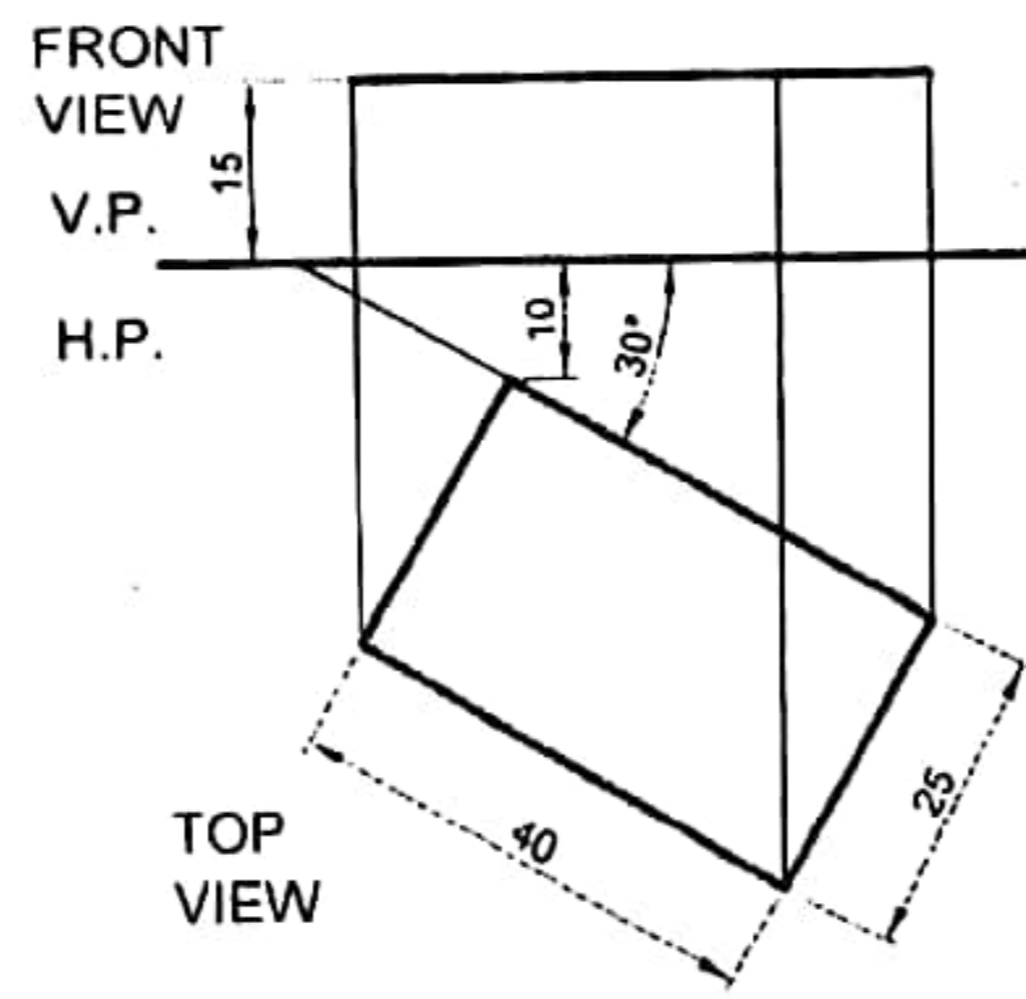

A square lamina of 25mm sides is perpendicular to HP and two sides of square is equally inclined to HP. One corner of the square is 10 mm above the HP and 15 mm in front of VP.

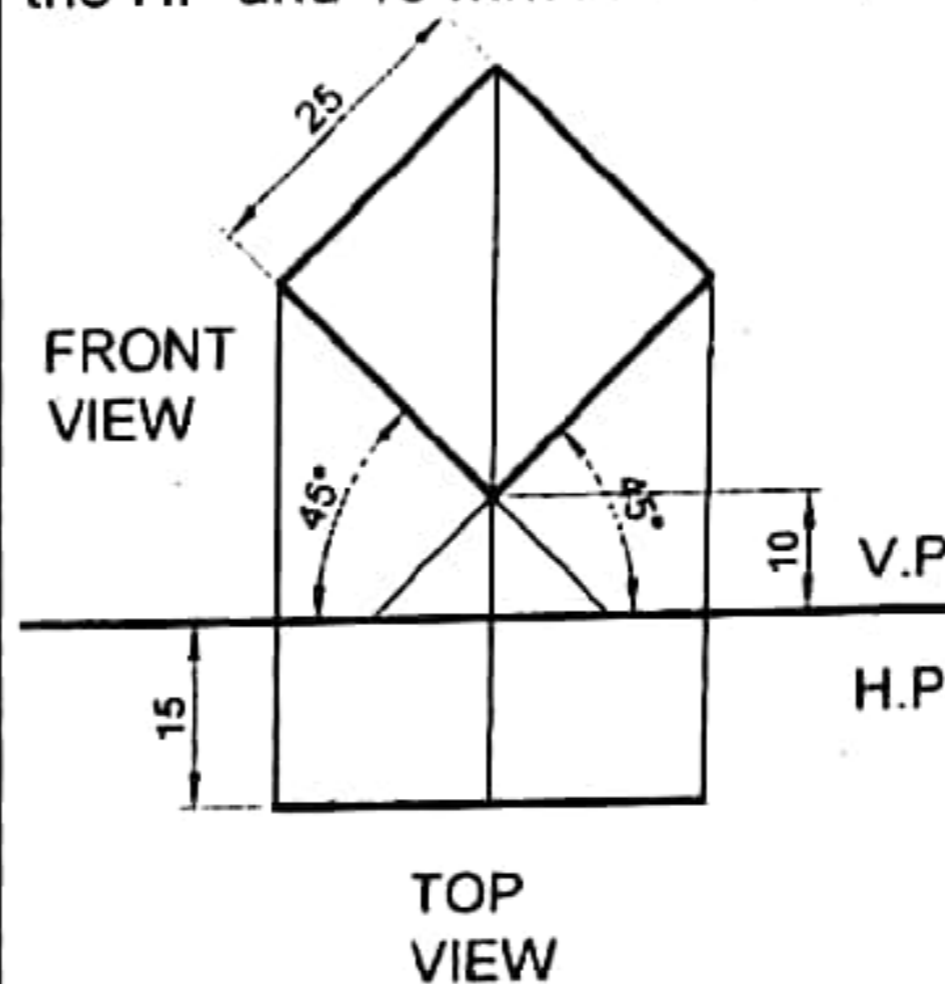

A square lamina of 25mm sides is perpendicular to HP and two sides of square is parallel to HP. One nearest side from HP and VP is 10mm. Draw the projection of plane.

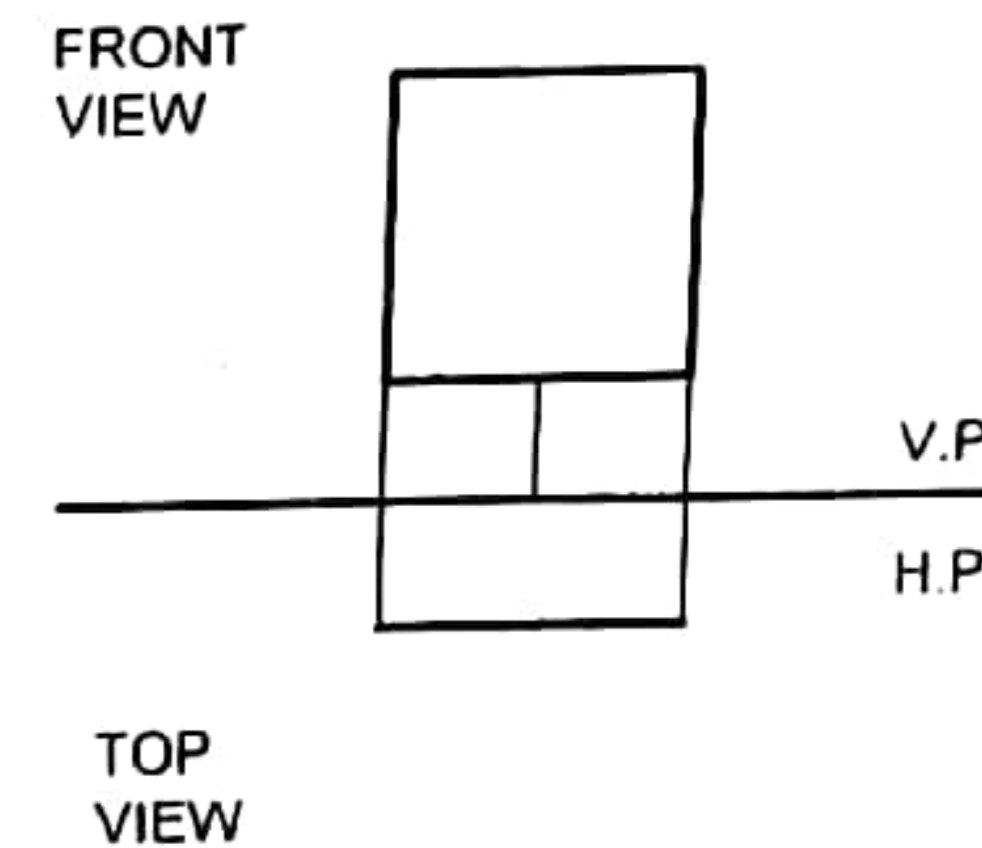

A REGULAR PENTAGON OF 30MM SIDES IS PERPENDICULAR TO HP AND INCLINED TO VP AT 30°, ONE SIDE OF PENTAGON IS ON HP AND NEAREST CORNER IS 15MM IN FRONT OF VP, DRAW ITS PROJECTION.

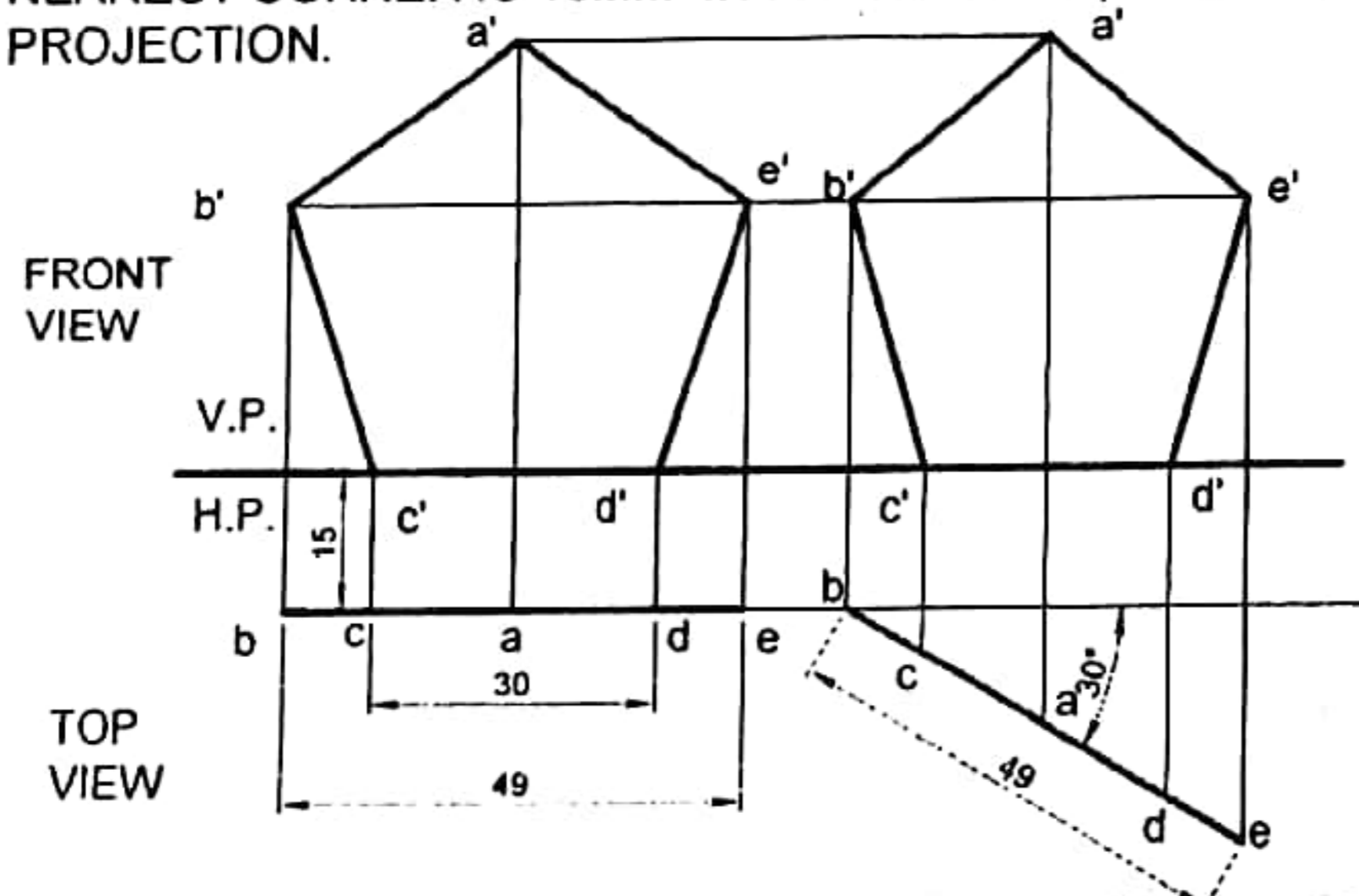

DRAW THE PROJECTION OF A THIN CIRCULAR SHEET OF 36MM Ø, THIS PLANE IS PERPENDICULAR TO HP AND INCLINED TO VP AT 30°, ONE OF THE NEAREST POINT OF CIRCUMFERENCE IS 10MM IN FRONT OF VP AND 10MM ABOVE THE HP.

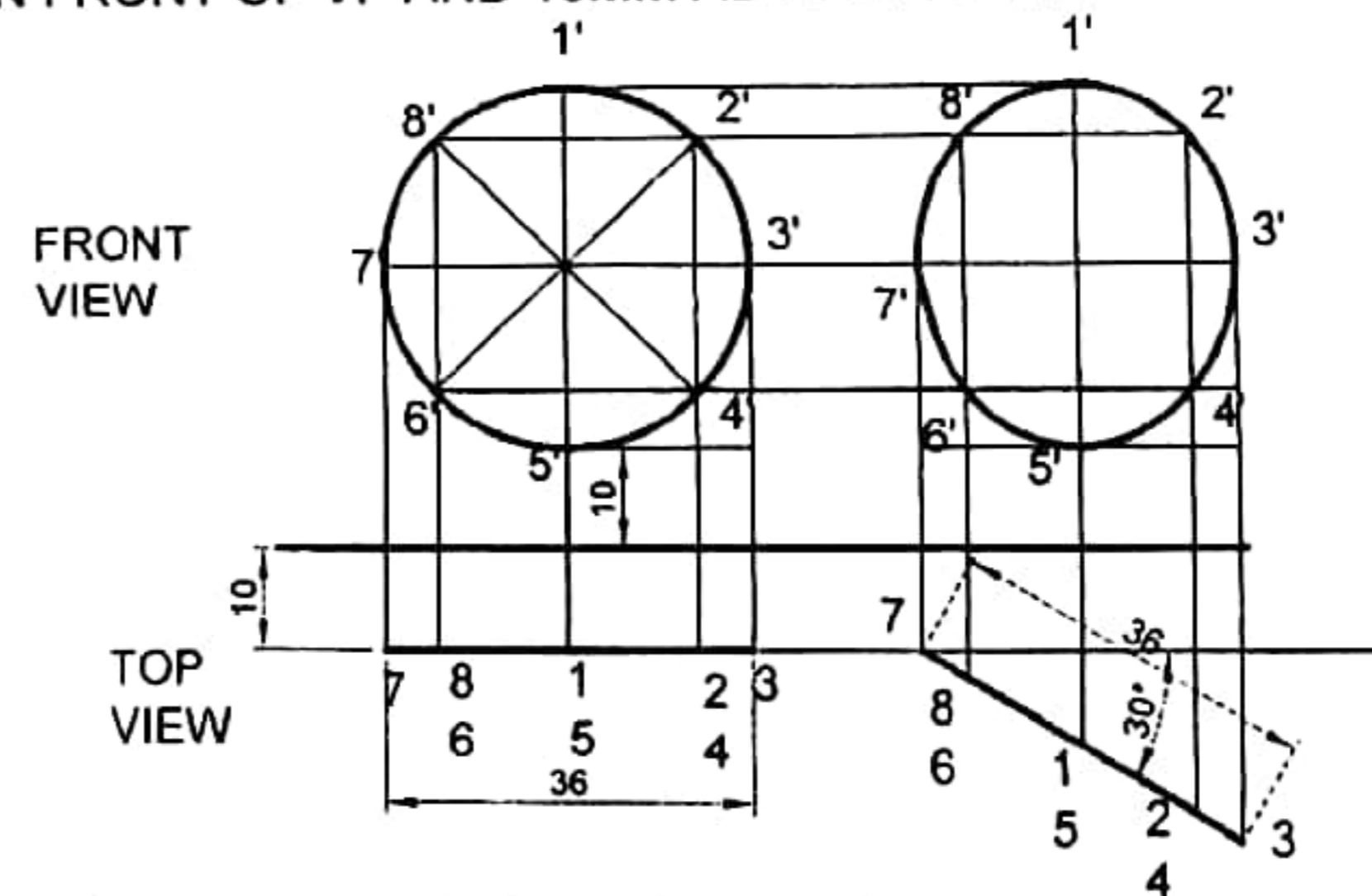

SUBJECT
ENGINEERING DRAWING

TOPIC
ORTHOGRAPHIC
PROJECTION
PROJECTION OF PLANES

DRAWN BY
NAME
ROLL NO

CHECKED BY
DATE

DATE

SCALE

DRAWING NO

DG-6

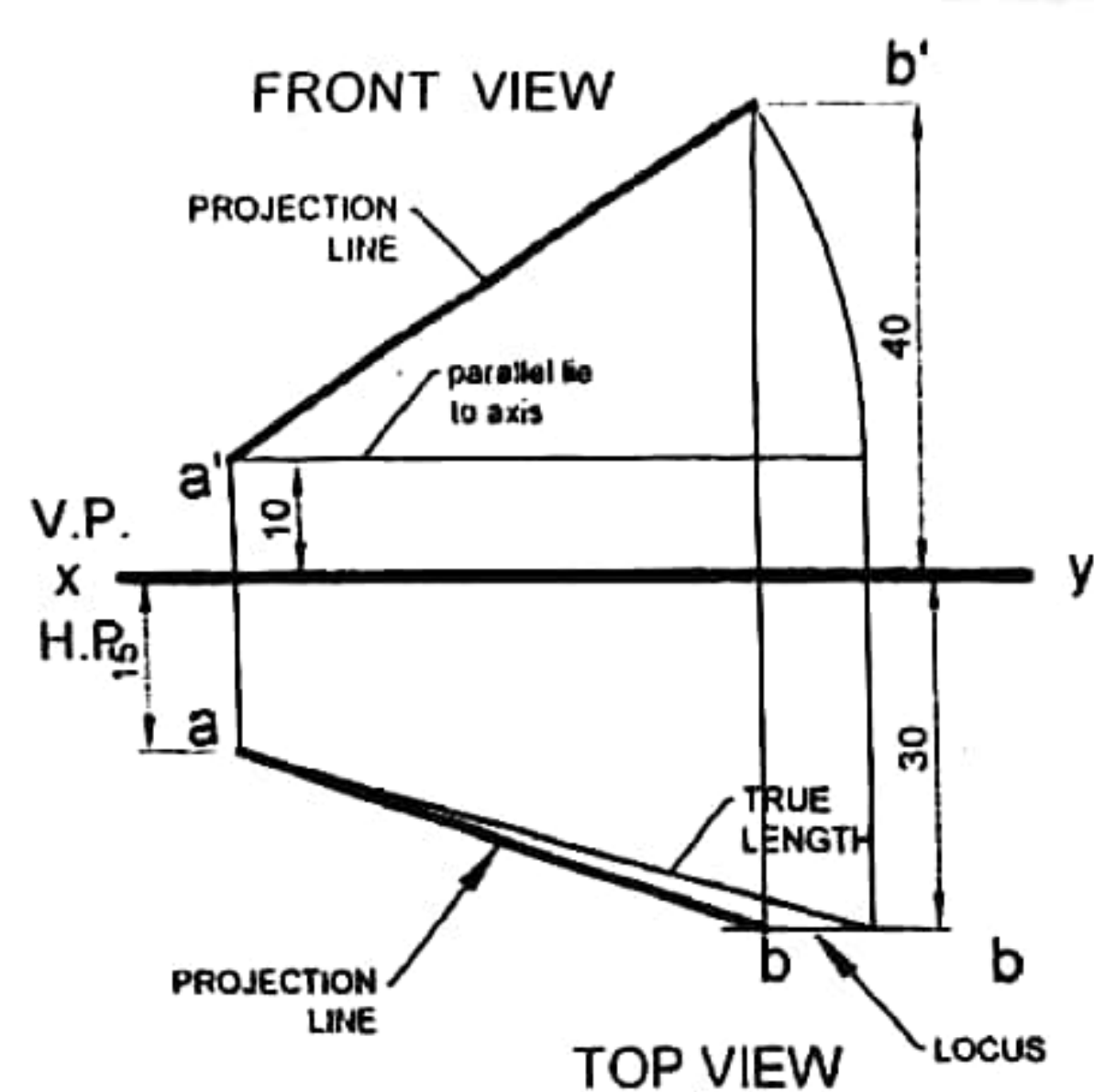

FINDING THE TRUE LENGTH OF LINE BY REVOLVING METHOD

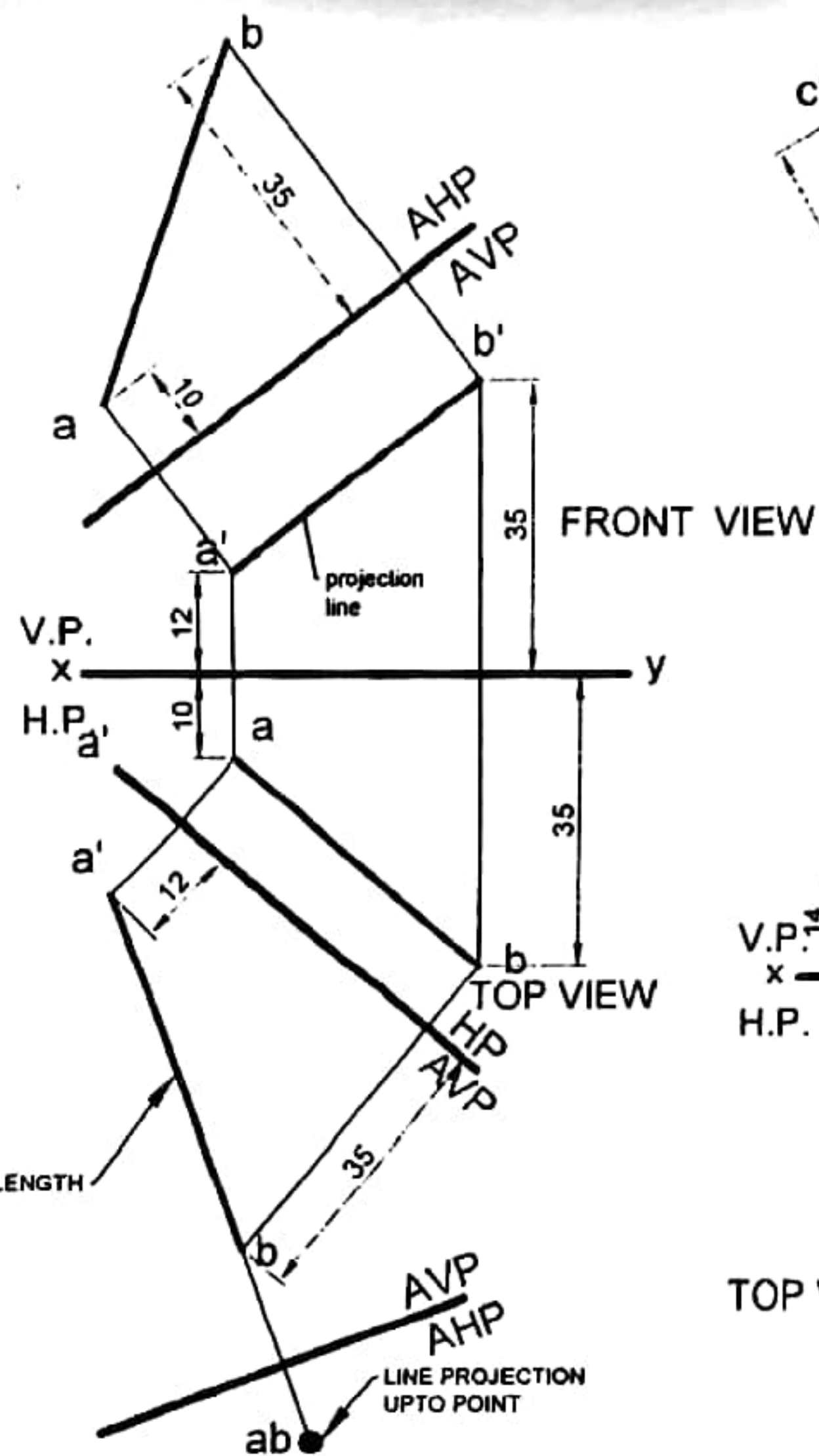

FINDING THE TRUE LENGTH OF A LINE BY AUXILIARY VIEW (REPLACING) METHOD

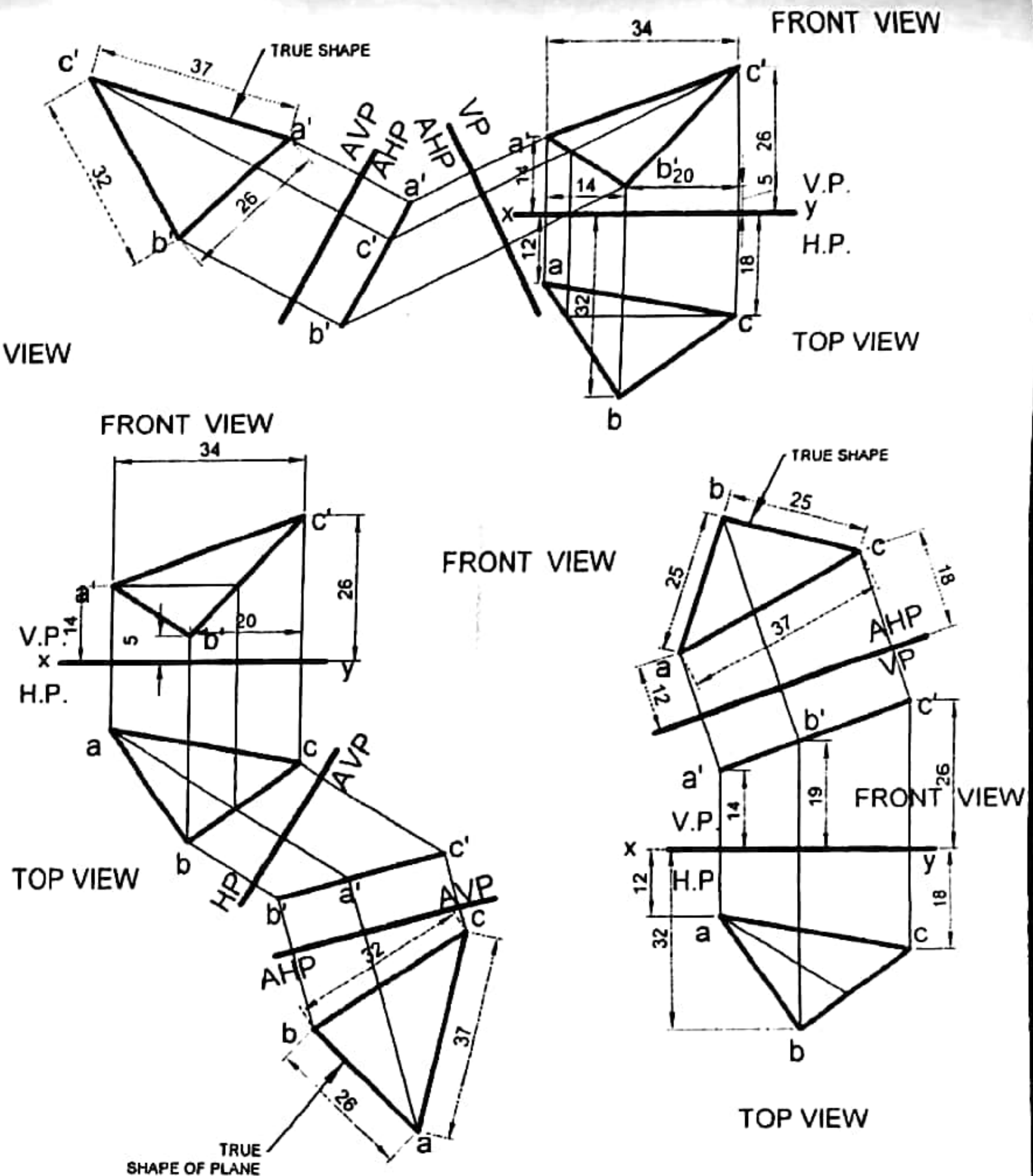

FINDING THE TRUE SHAPE OF A PLANE BY AUXILIARY VIEW (REPLACING) METHOD

SUBJECT ENGINEERING DRAWING	TITLE FINDING THE TRUE LENGTH AND SHAPE	DRAWN BY NAME ROLL NO	CHECKED BY	DATE	SCALE
				DATE	DRAWING NO DG-7

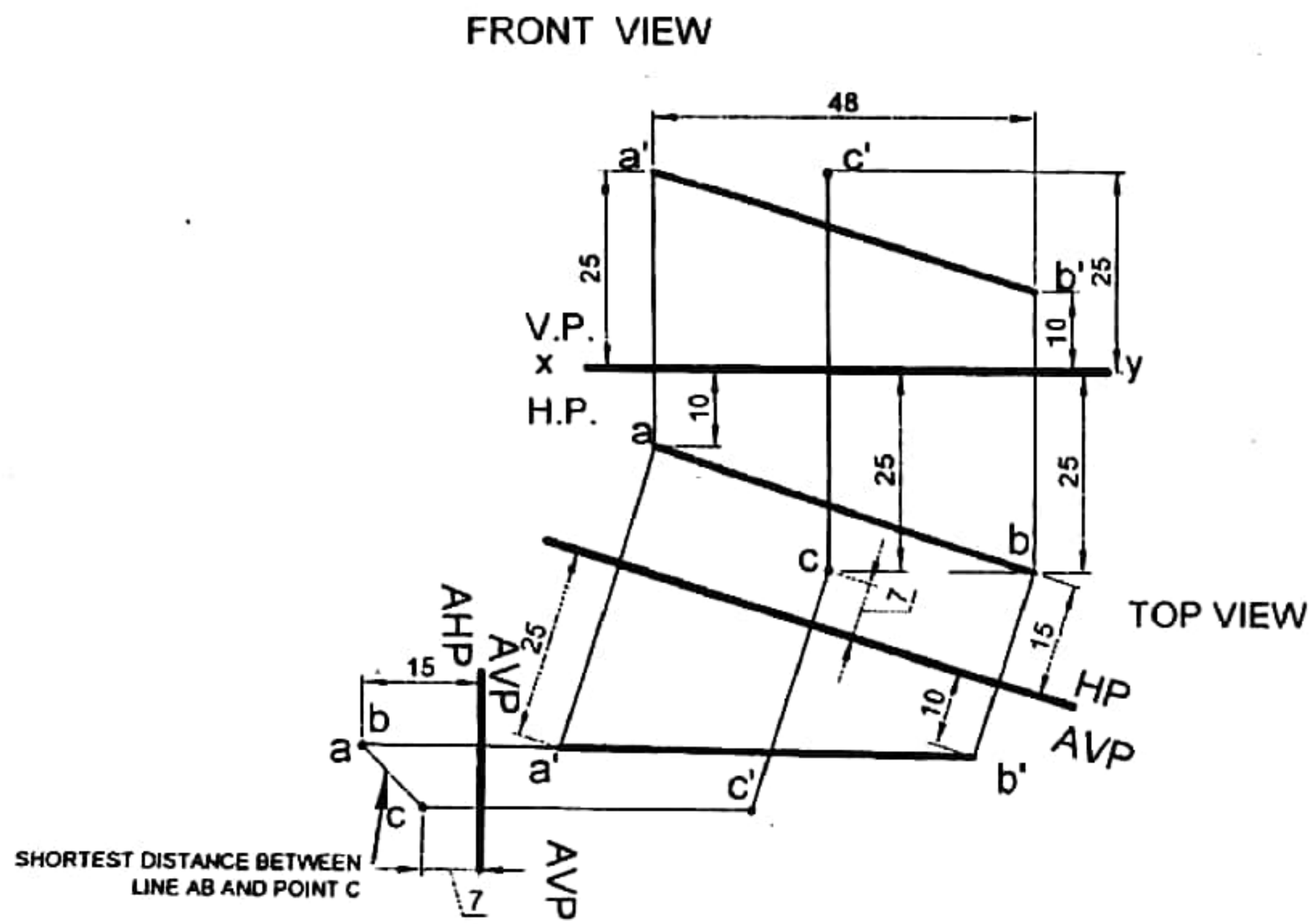

FINDING THE SHORTEST DISTANCE BETWEEN LINE AND POINT

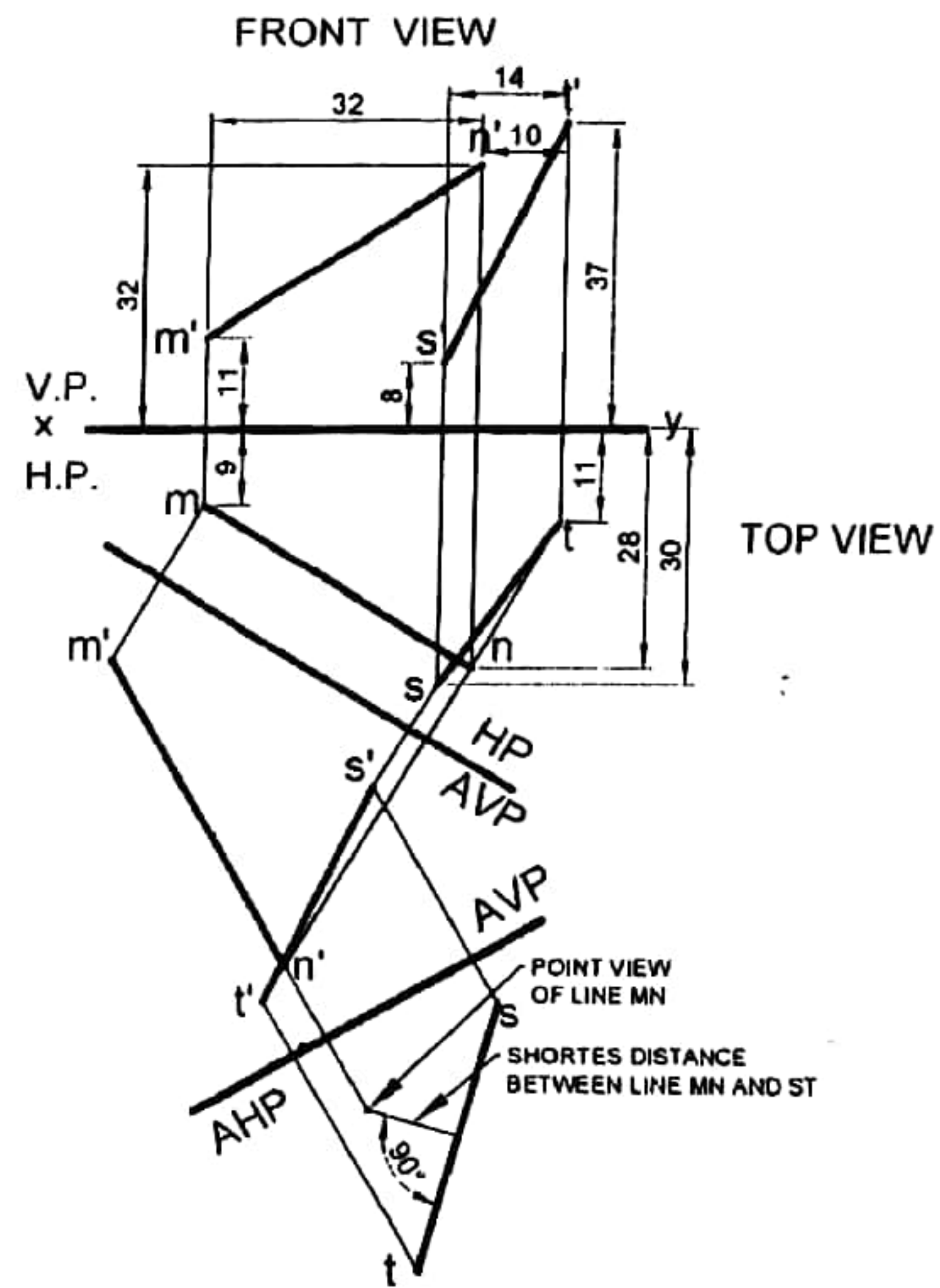

FINDING THE SHORTEST DISTANCE LINE MN AND ST

SUBJECT ENGINEERING DRAWING	TITLE DESCRIPTIVE GEOMETRY SHORTEST DISTANCE	DRAWN BY NAME ROLL NO	CHECKED BY	DATE	SCALE
				DATE	DRAWING NO DG-8

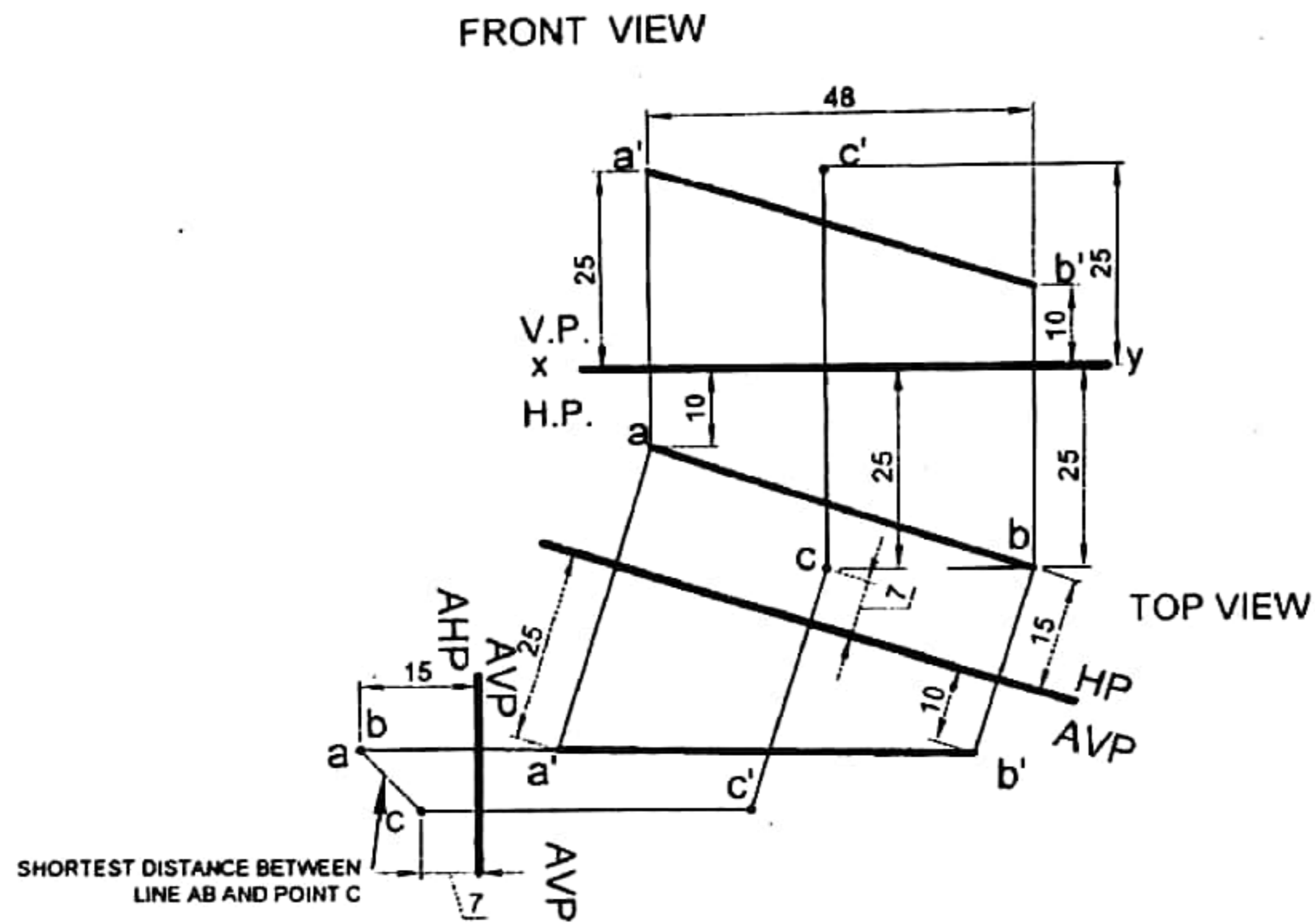

FINDING THE SHORTEST DISTANCE BETWEEN LINE AND POINT

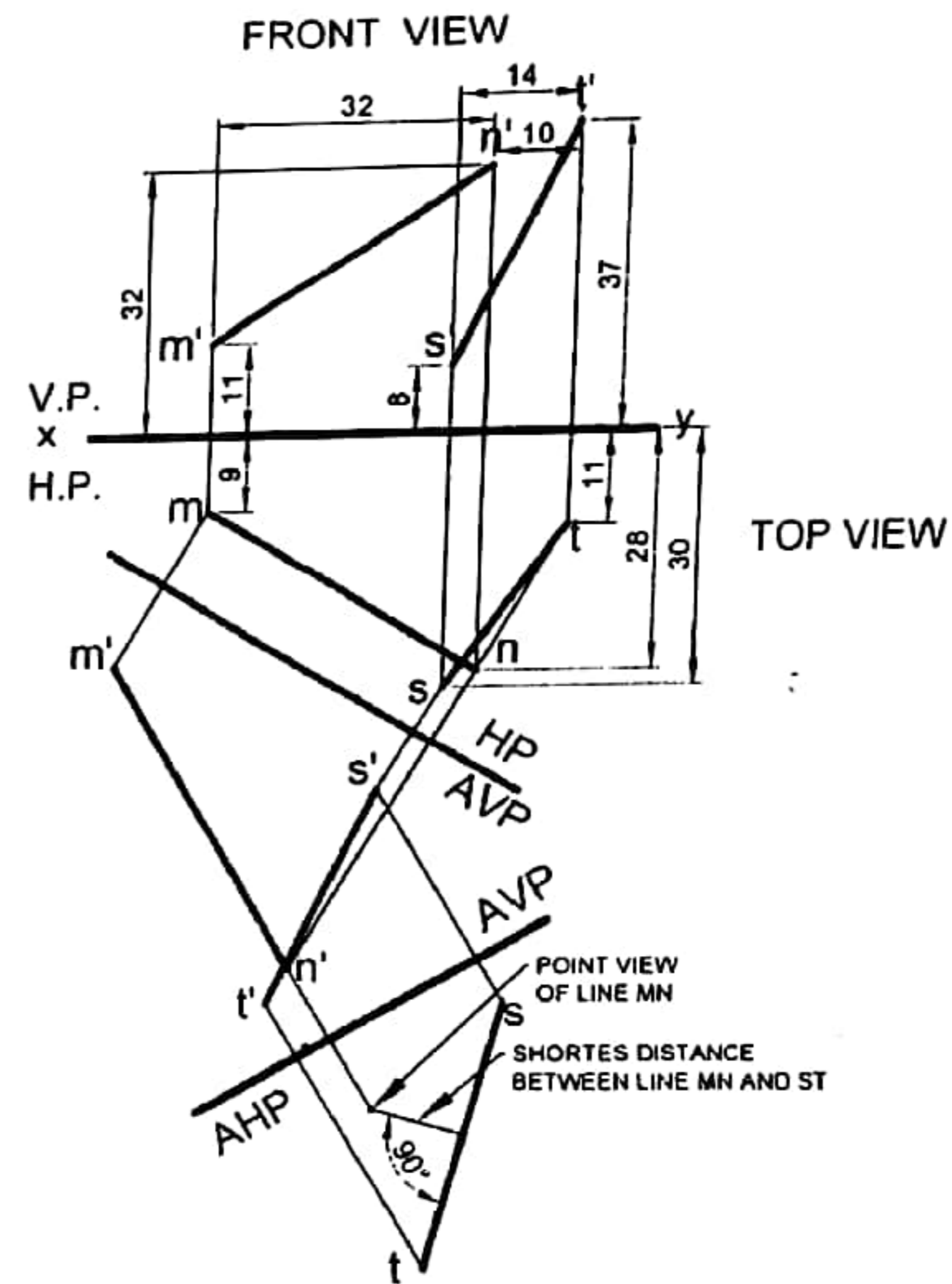

FINDING THE SHORTEST DISTANCE LINE MN AND ST

	SUBJECT	TITLE	DRAWN BY	CHECKED BY	DATE	SCALE
	ENGINEERING DRAWING	DESCRIPTIVE GEOMETRY SHORTEST DISTANCE	NAME ROLL NO			
				DATE	DRAWING NO DG-8	

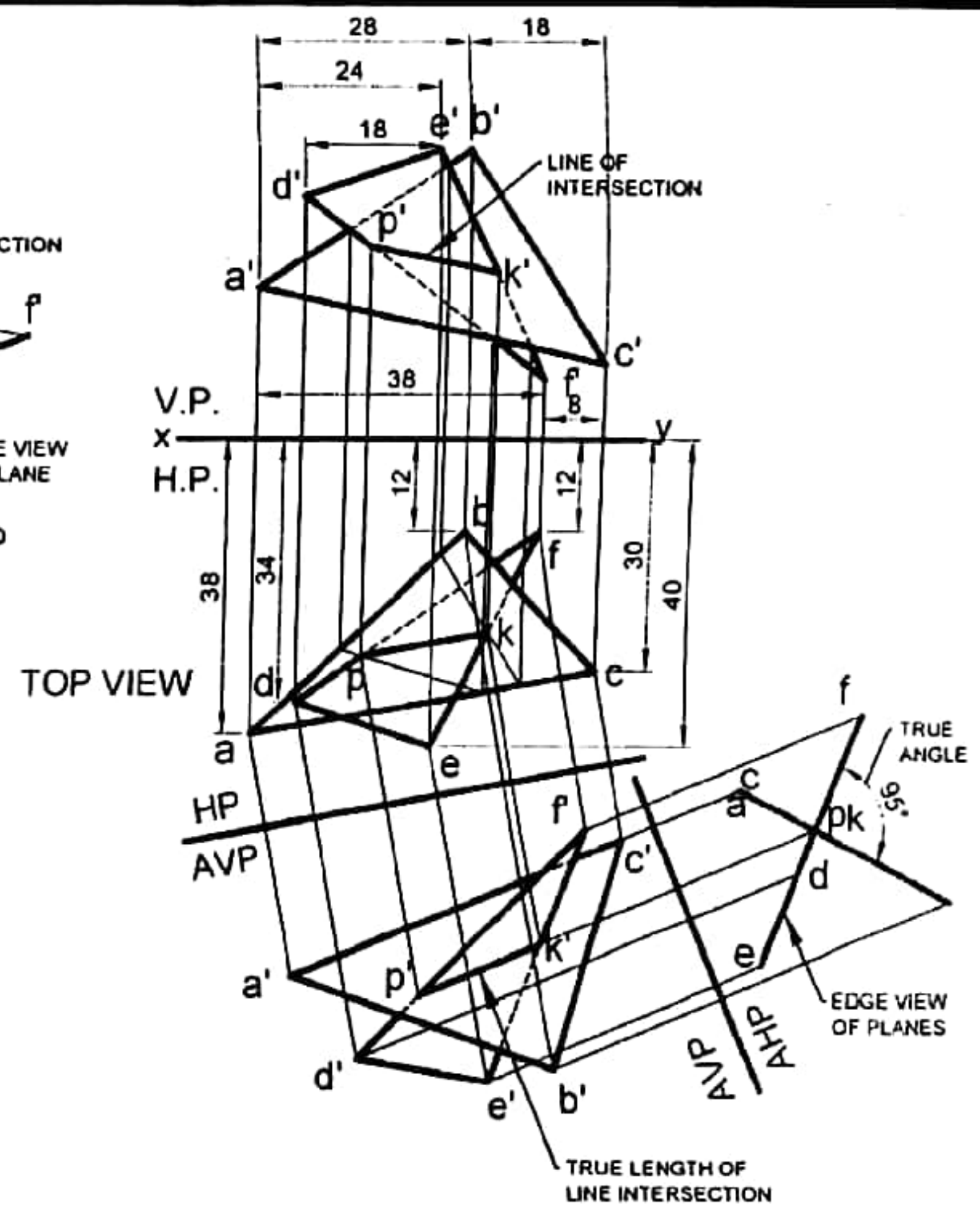
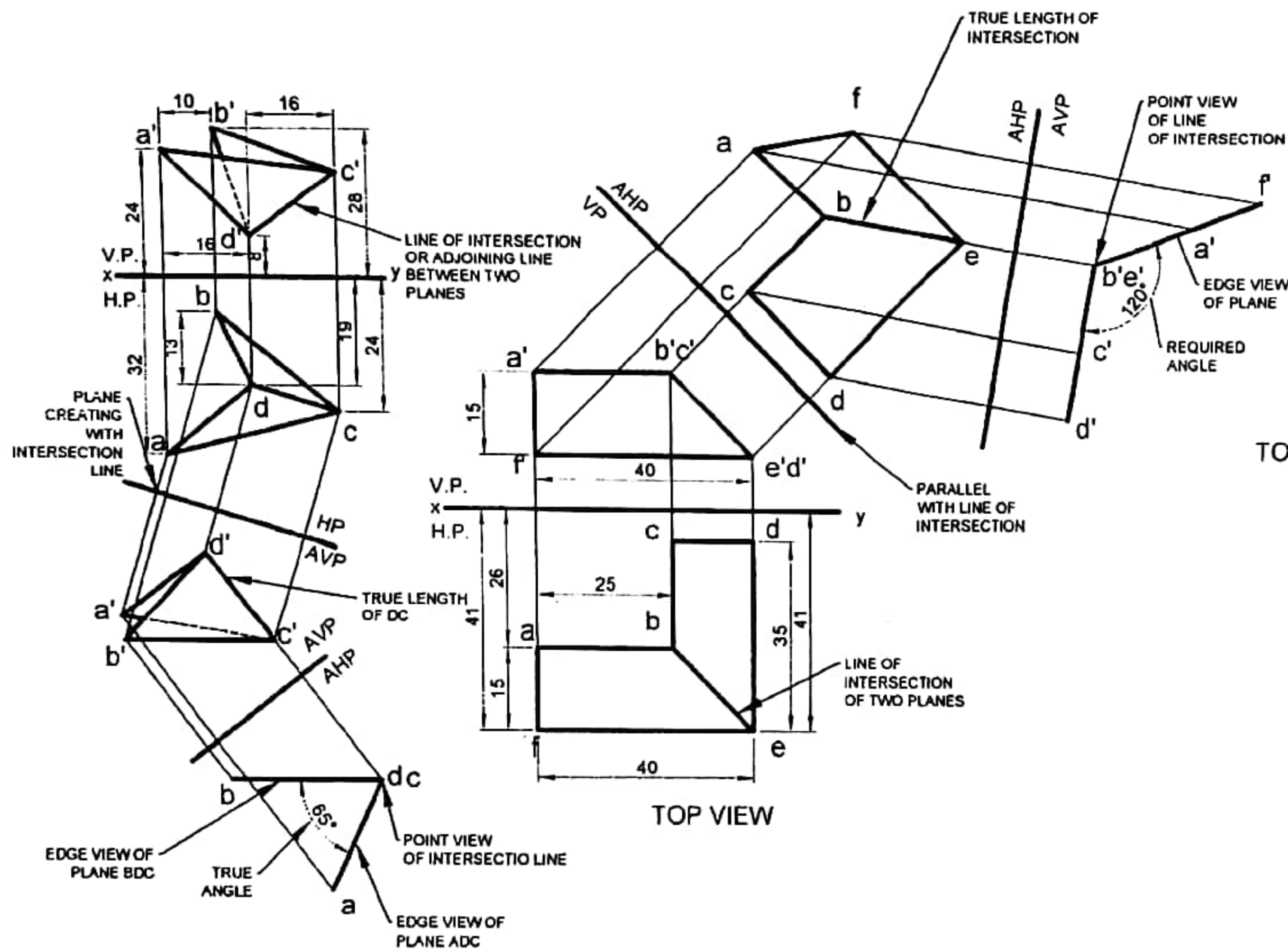

	PLANE 1			PLANE 2		
	A	B	C	D	E	F
x	51	23	05	45	27	13
y	38	12	30	41	23	19
z	20	38	10	34	40	12

FINDING THE ANGLE BETWEEN TWO INTERSECTION PLANE

	SUBJECT	TITLE	DRAWN BY	CHECKED BY	DATE	SCALE
	ENGINEERING DRAWING	DESCRIPTIVE GEOMETRY FINDING THE ANGLE BETWEEN TWO PLANES	NAME ROLL NO			
				DATE	DRAWING NO	DG-9

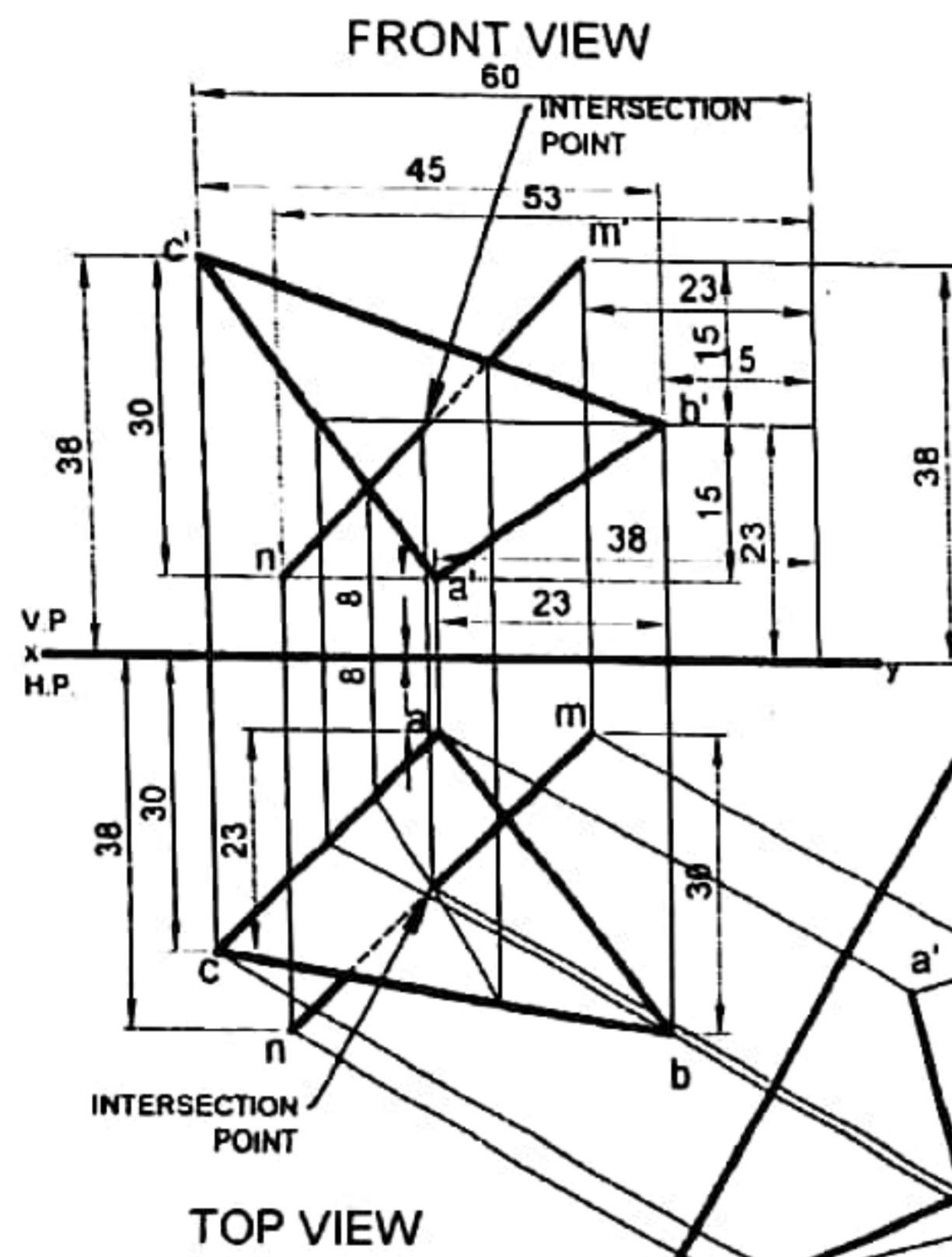

	PLANE			LINE	
	A	B	C	M	N
x	38	15	60	23	53
y	8	38	30	9	47
z	8	23	38	8	38

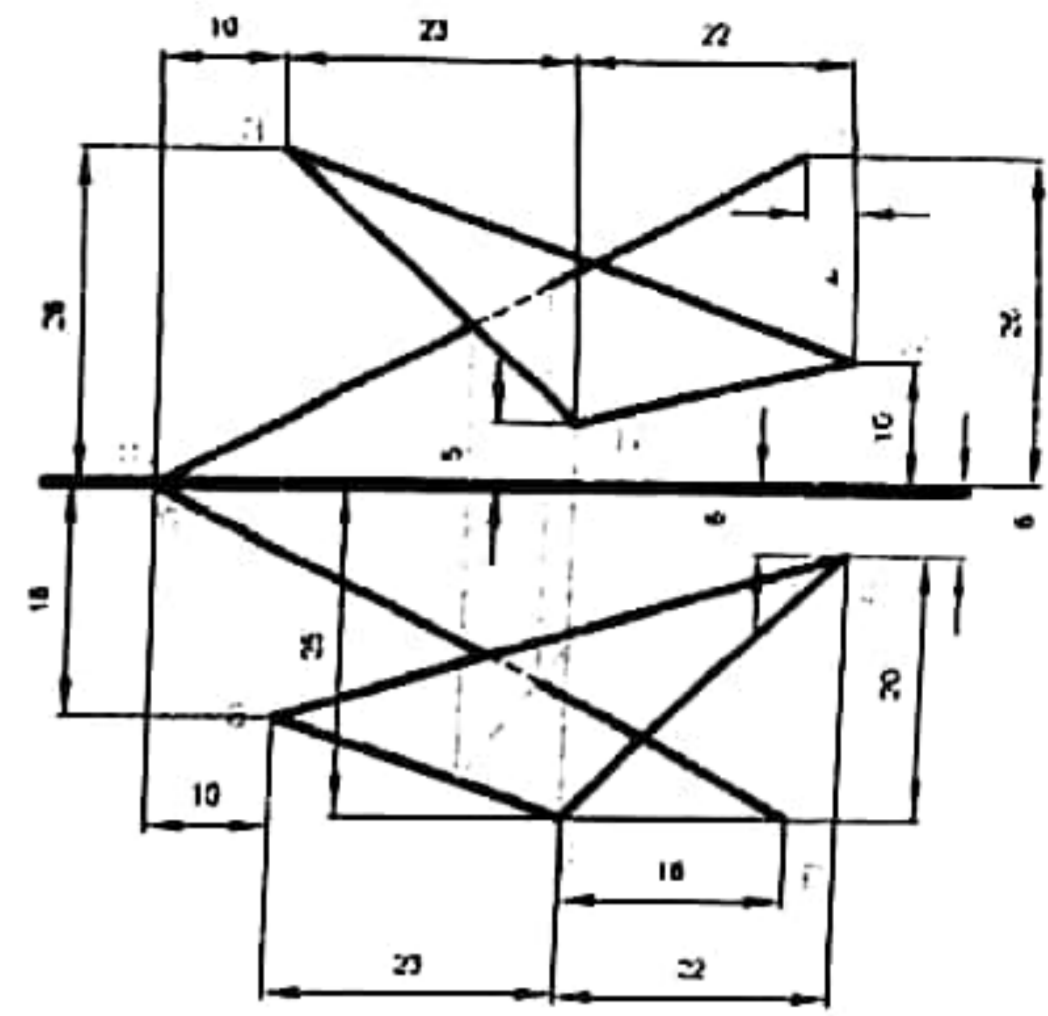
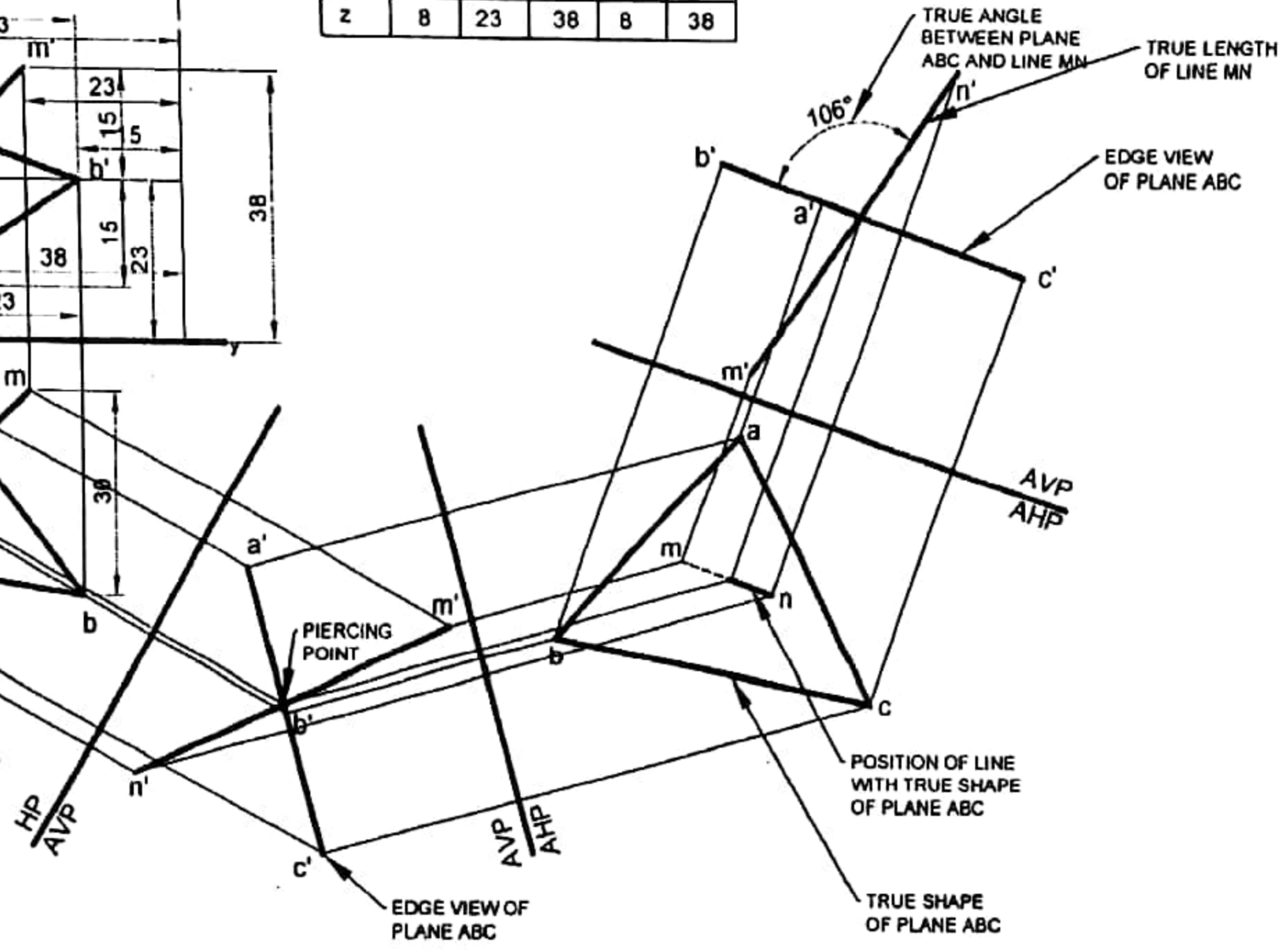

	PLANE			LINE	
	A	B	C	M	N
x	54	31	9	64	13
y	19	25	5	0	25
z	26	5	10	0	26

FINDING THE ANGLE BETWEEN PLANE AND LINE
(INTERSECTION BETWEEN PLANE AND LINE)

SUBJECT
ENGINEERING DRAWING

TITLE
DESCRIPTIVE GEOMETRY
INTERSECTION BETWEEN LINE AND PLANE (FINDING THE TRUE SHAPE AND LENGTH AND TRUE ANGLE BETWEEN LINE AND PLANE)

DRAWN BY
NAME
ROLL NO

CHECKED BY
DATE

DATE

SCALE

DRAWING NO

DG- 10

FINDING THE MISSING POINTS AND LINE ON THE SURFACE OF SQUARE BASE PYRAMID

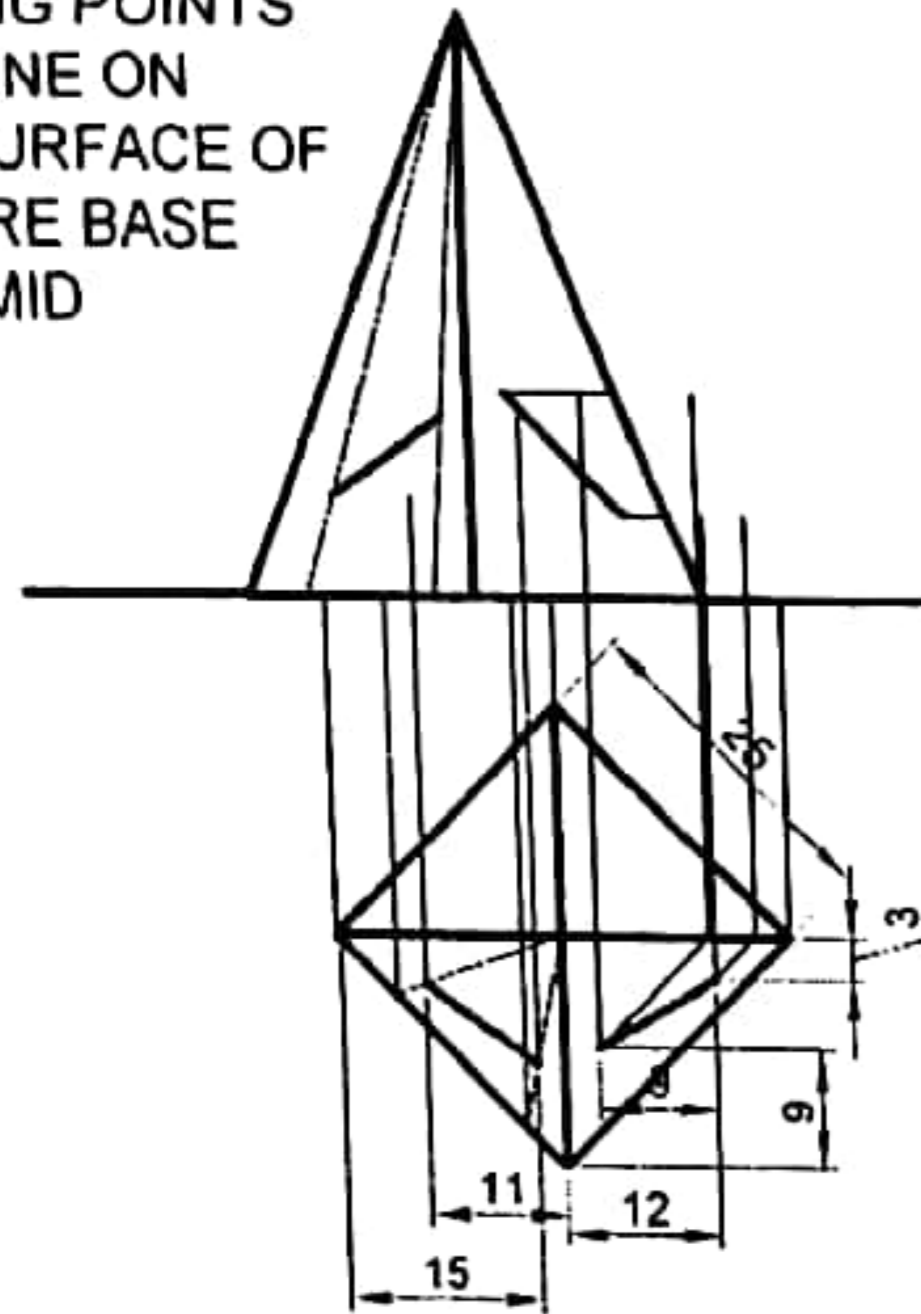

FINDING THE MISSING POINTS AND LINE ON THE SURFACE OF SQUARE BASE PYRAMID

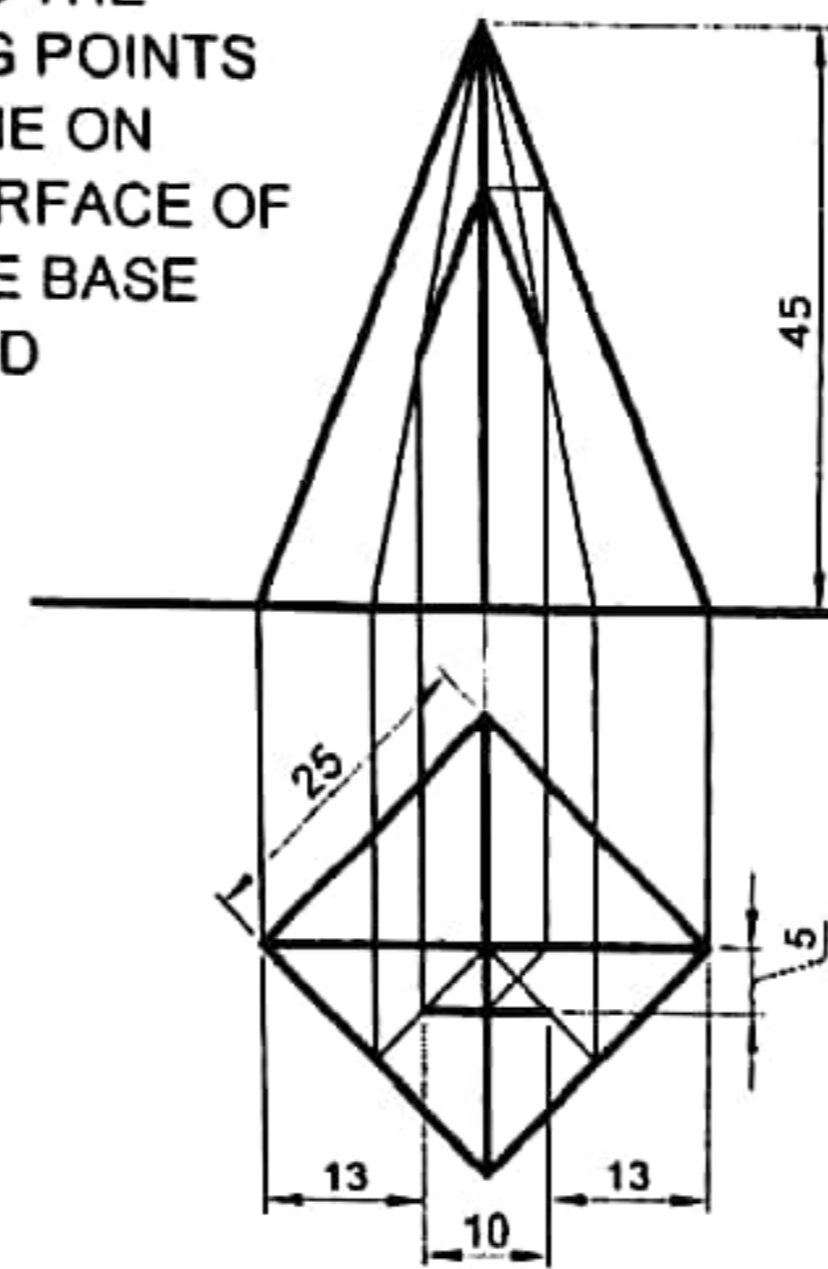

FINDING THE MISSING POINTS AND LINE ON THE SURFACE OF PENTAGONAL BASE PYRAMID

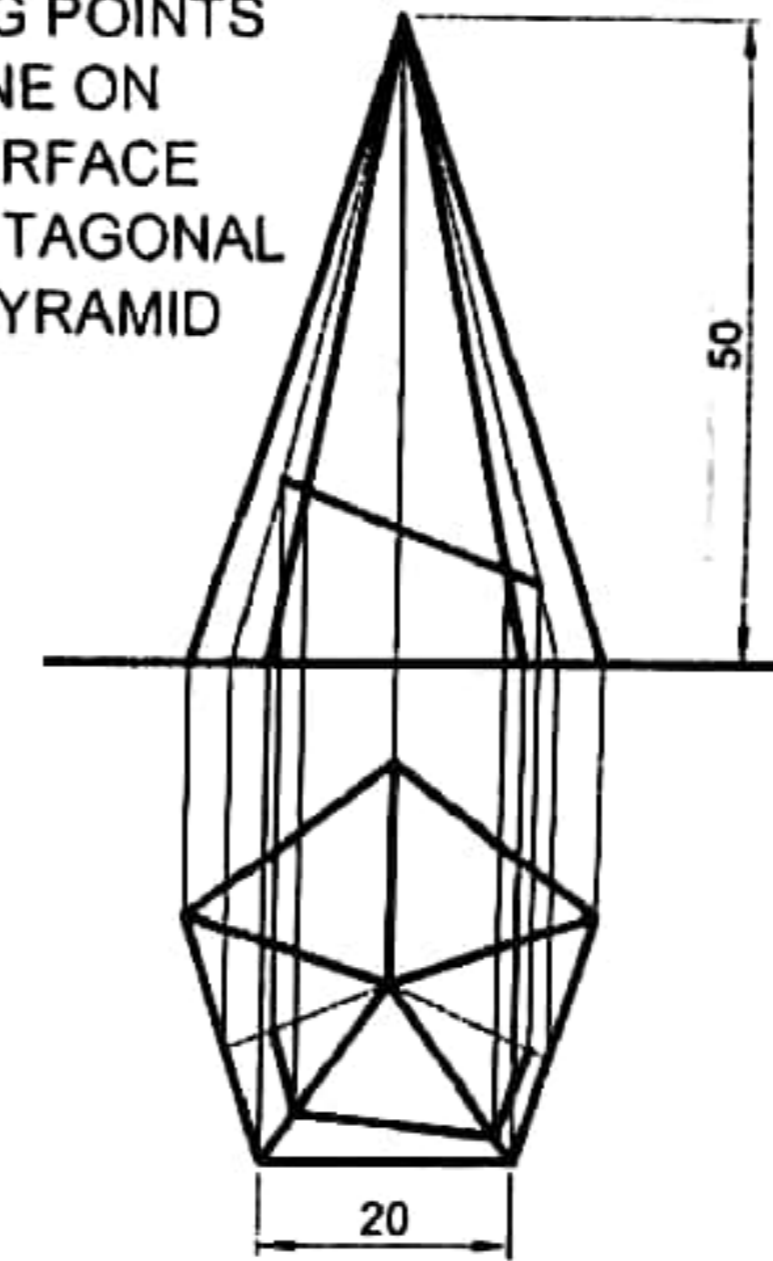

FINDING THE MISSING POINTS AND LINE ON THE SURFACE OF HEXAGONAL BASE PYRAMID

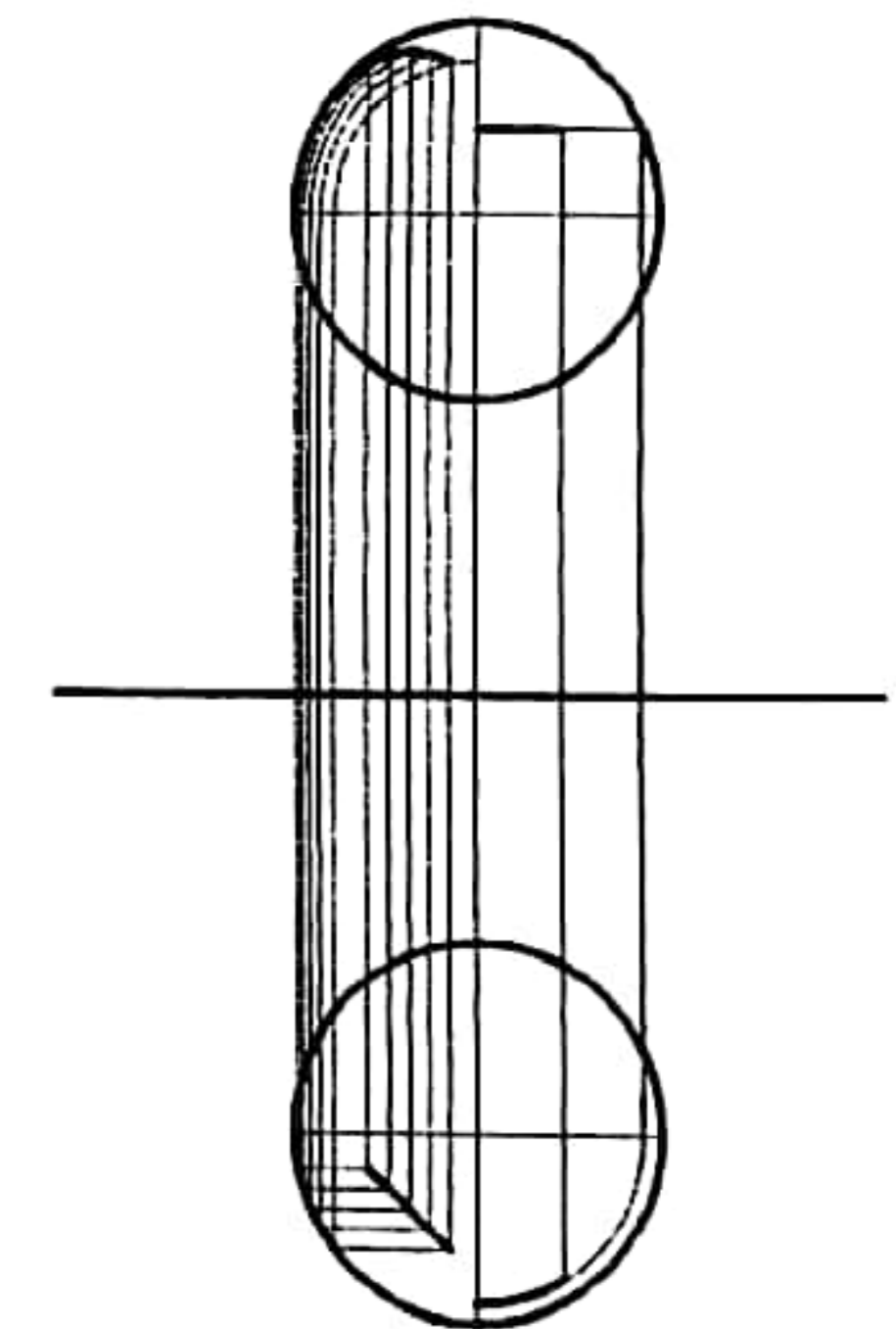
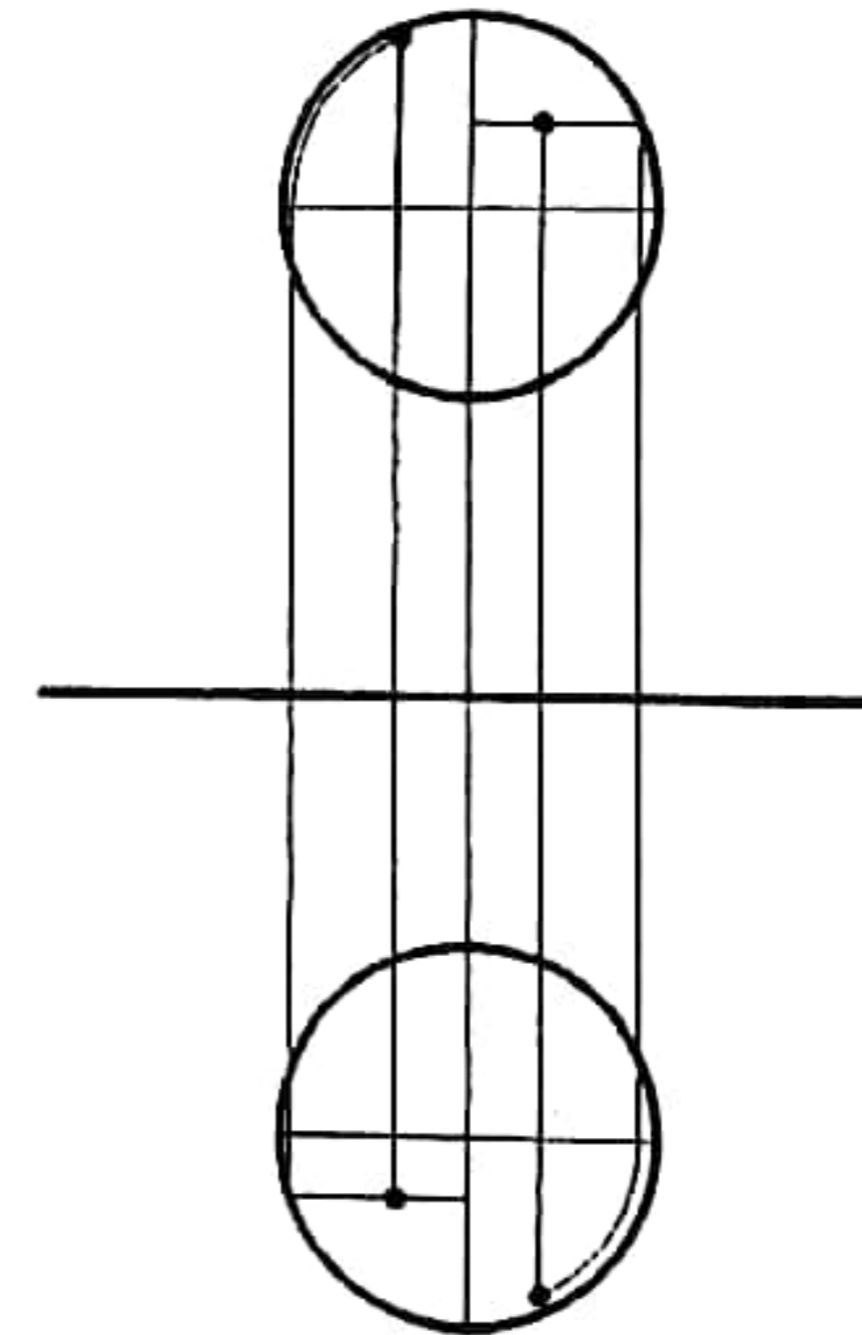
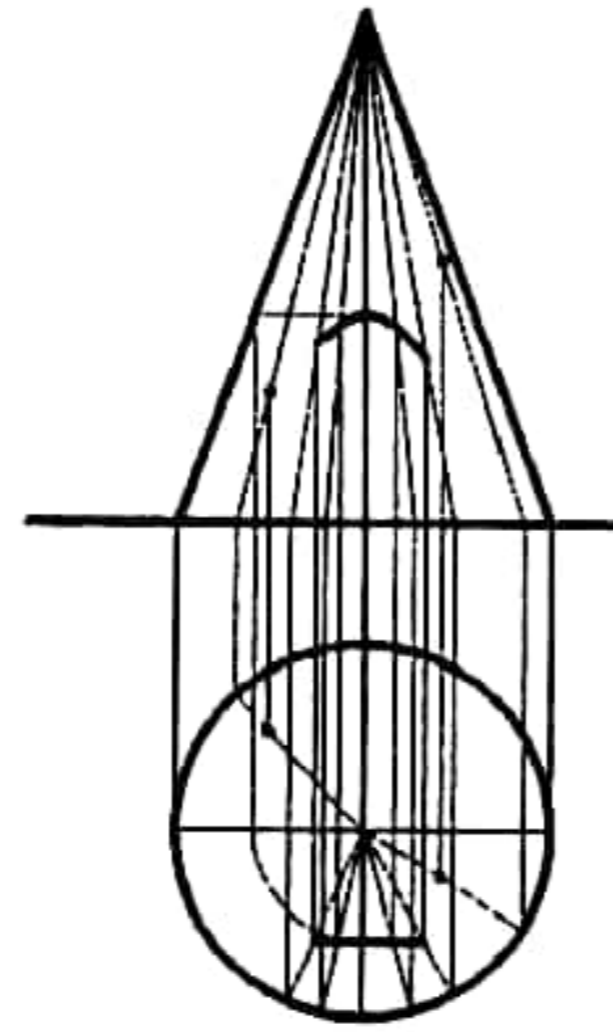
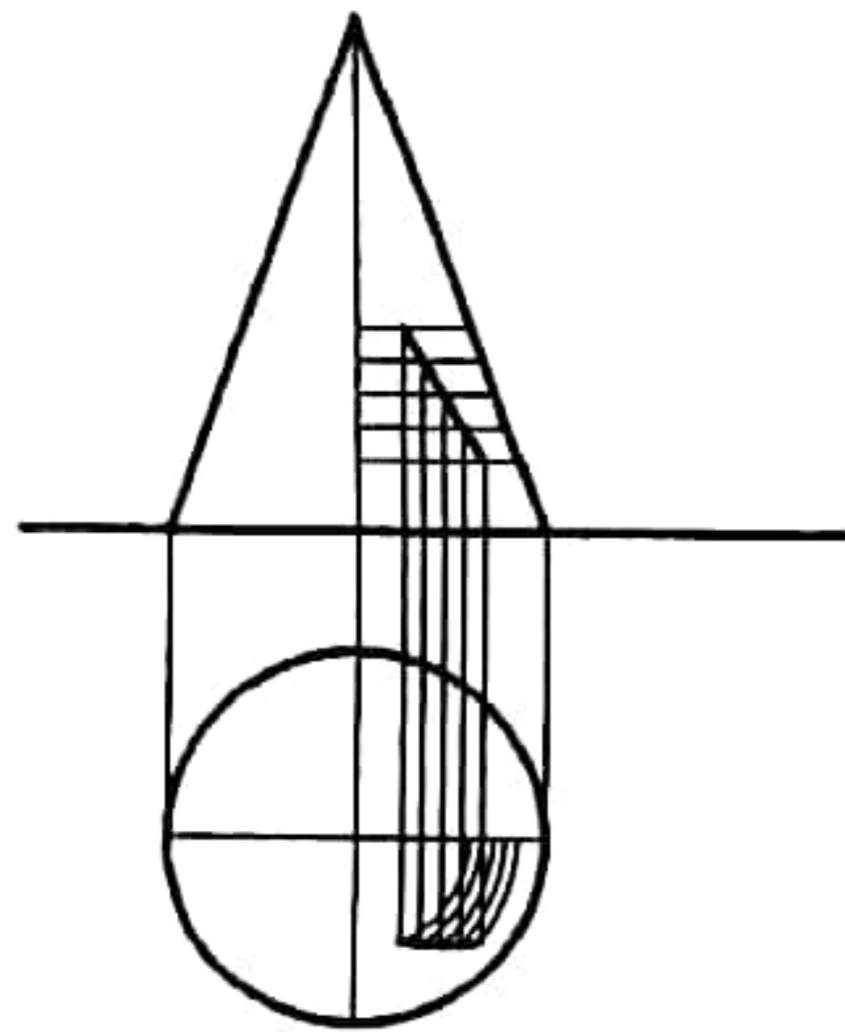
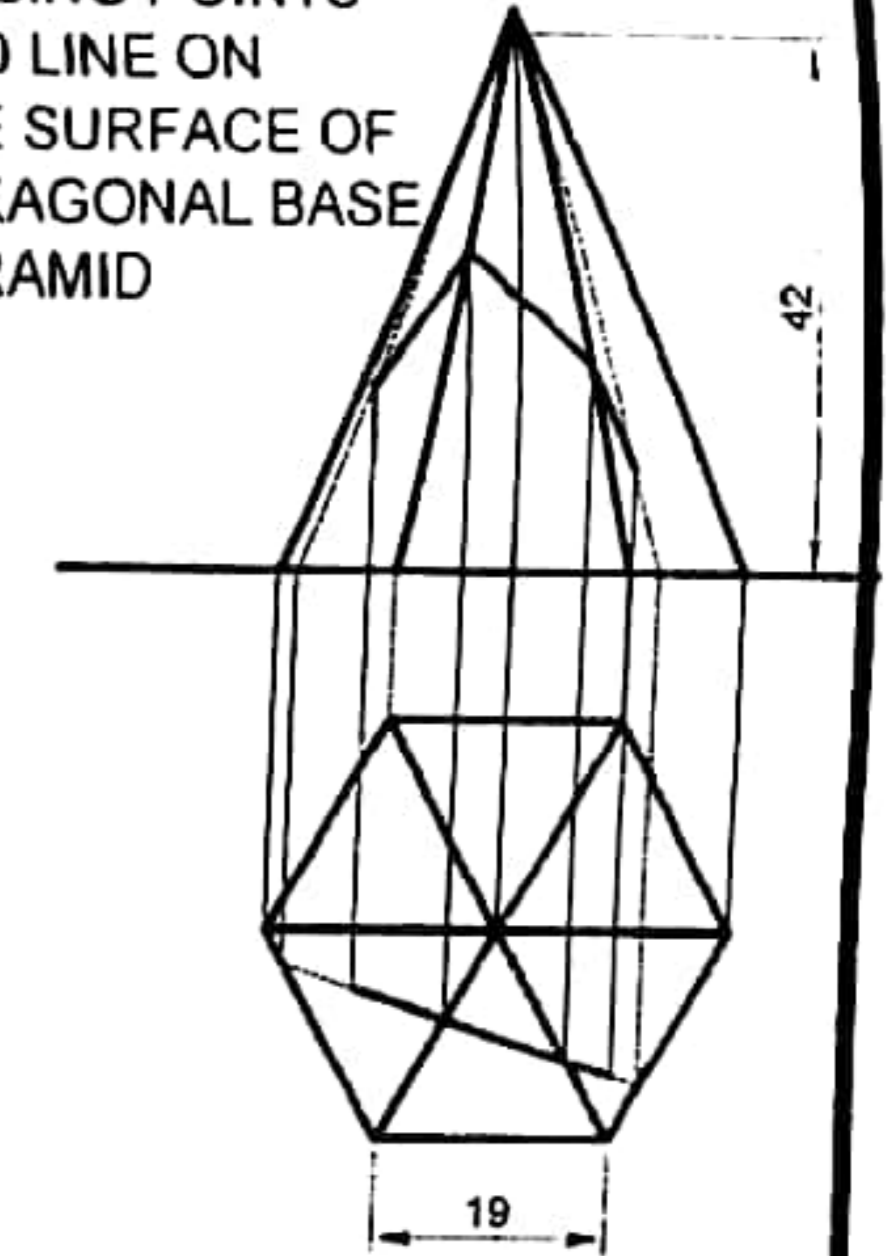

SUBJECT
ENGINEERING DRAWING

TITLE
FINDING THE MISSING POINTS AND LINES ON THE SURFACE OF GEOMETRICAL SOLIDS.

DRAWN BY
NAME
ROLL NO

CHECKED BY
DATE

DATE

SCALE

DRAWING NO

DG-11

FRONT VIEW

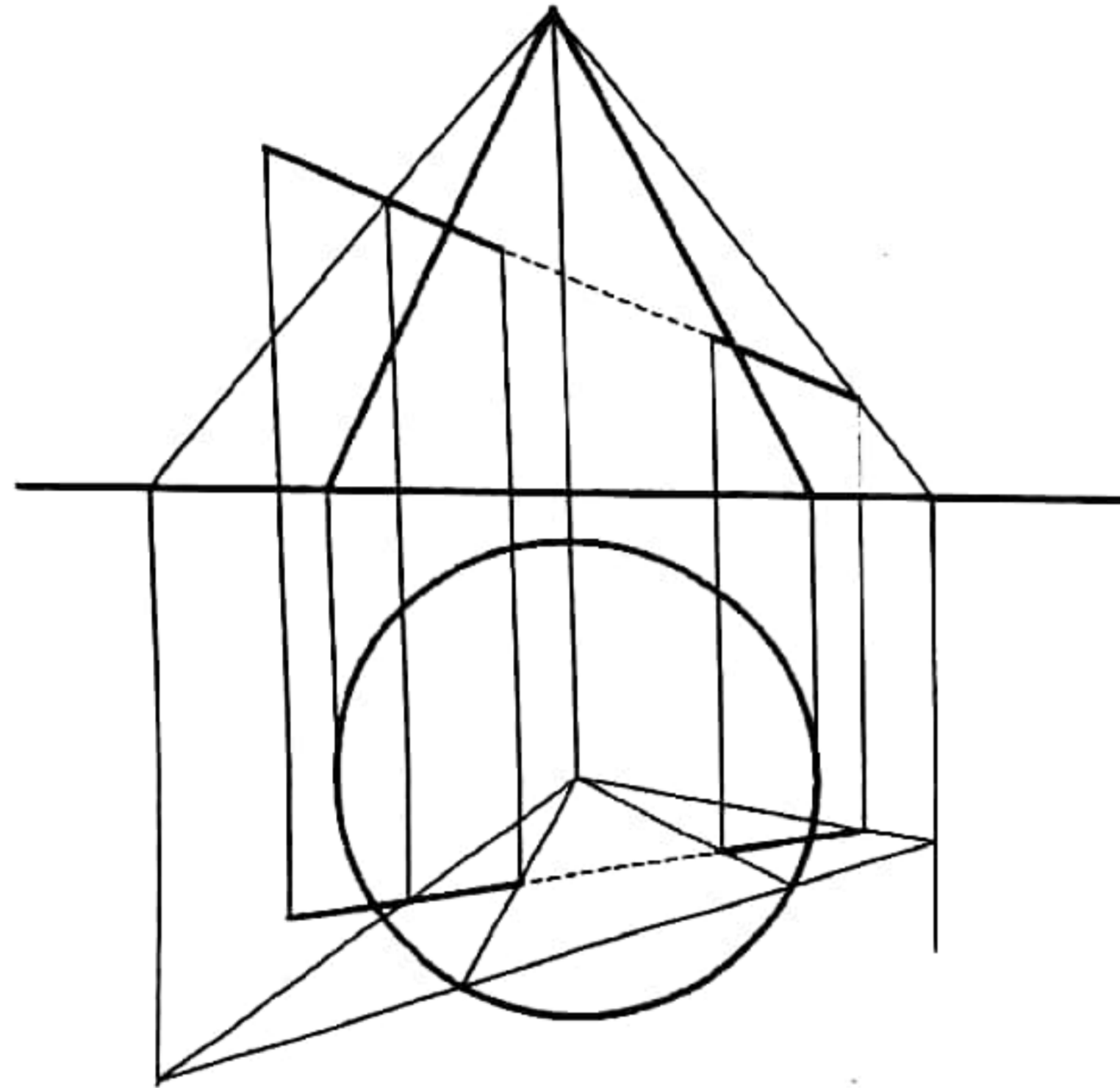

TOP VIEW

FRONT VIEW

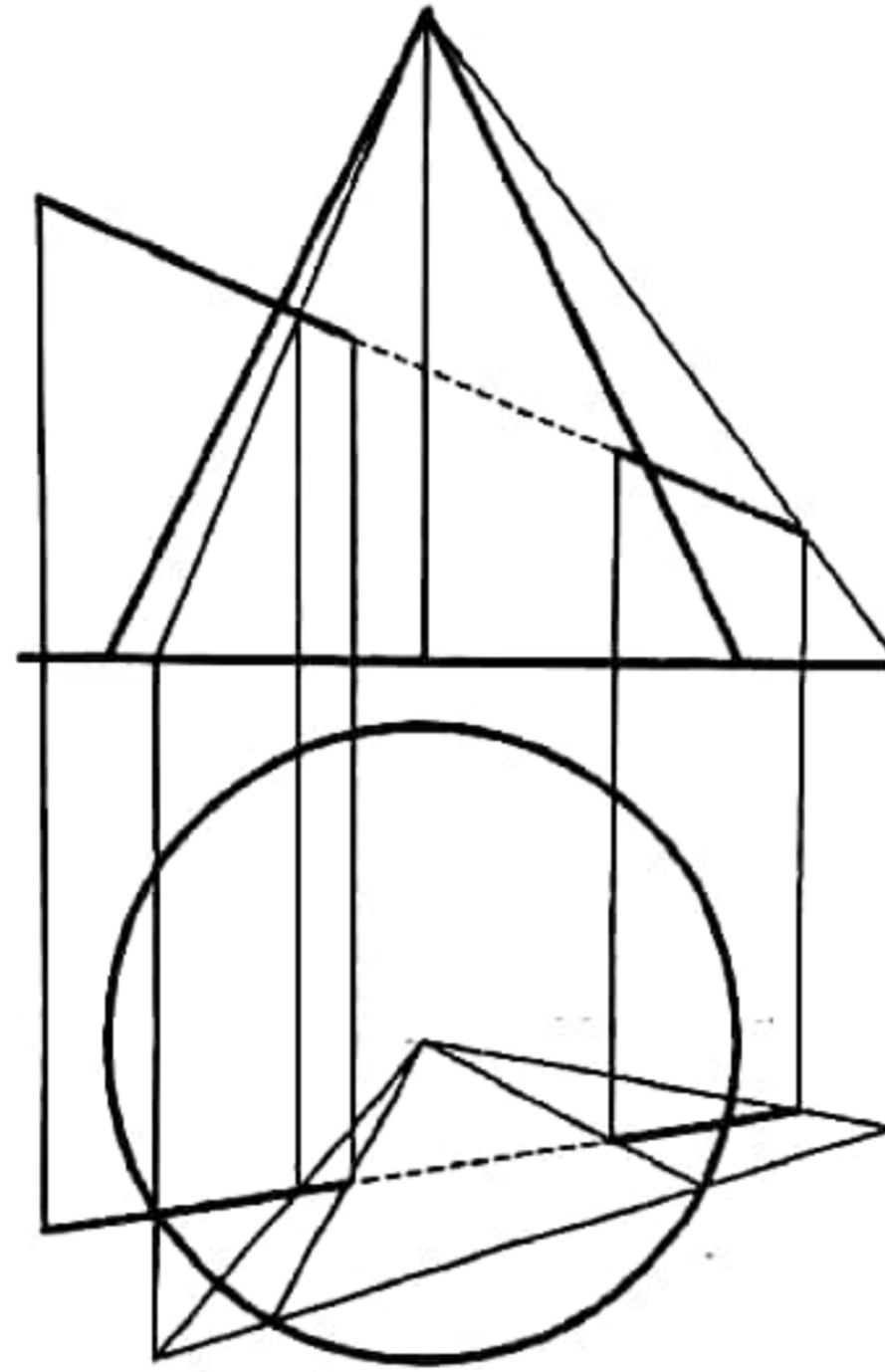

TOP VIEW

INTERSECTION BETWEEN CONE AND LINE

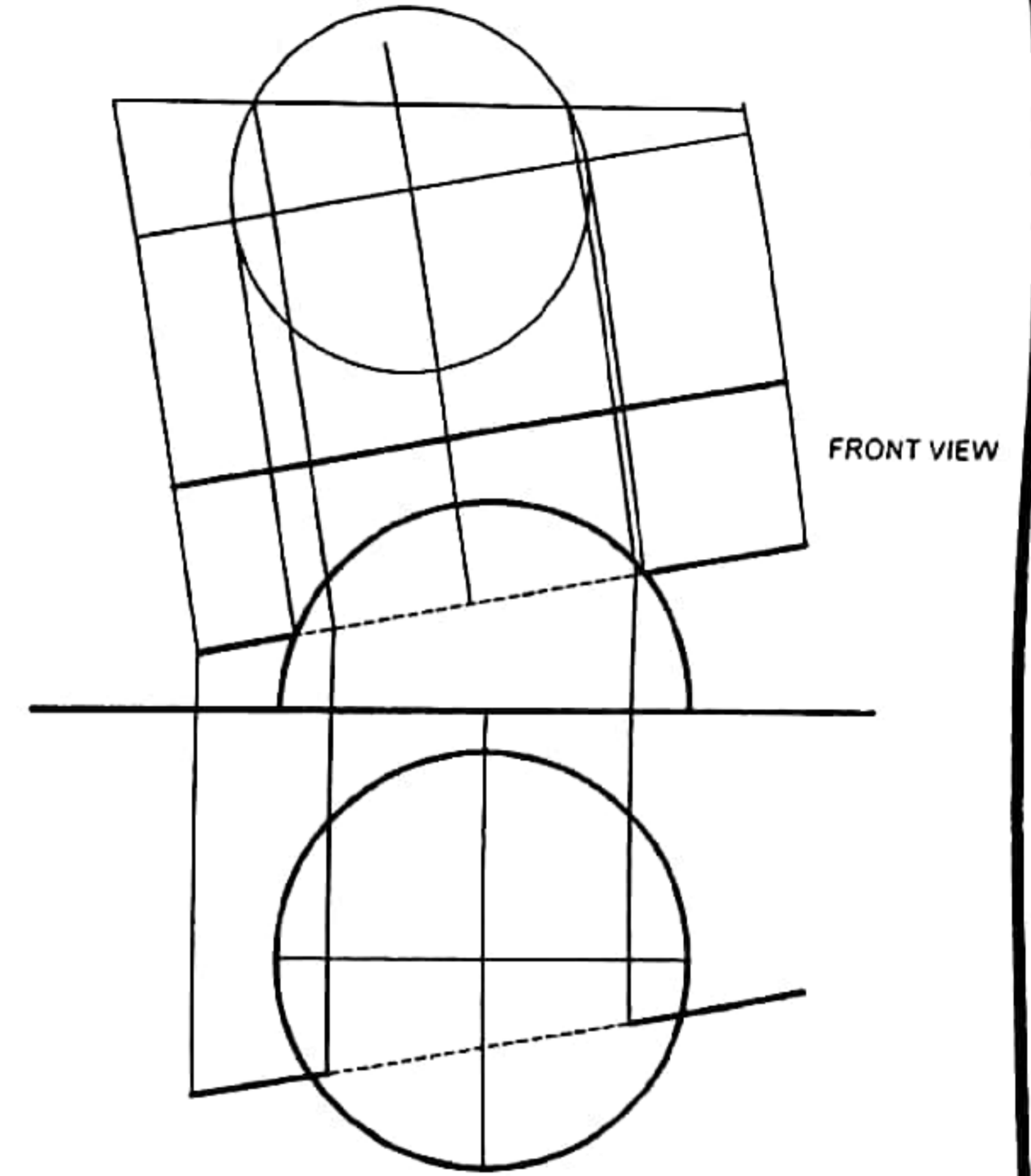

FRONT VIEW

TOP VIEW

INTERSECTION BETWEEN HEMISPHERE AND LINE

	SUBJECT ENGINEERING DRAWING	TITLE INTERSECTION BETWEEN LINE AND GEOMETRICAL SOLIDS	DRAWN BY NAME ROLL NO	CHECKED BY DATE	DATE DRAWING NO	SCALE DG-12
--	--------------------------------	---	-----------------------------	--------------------	--------------------	----------------

FRONT VIEW

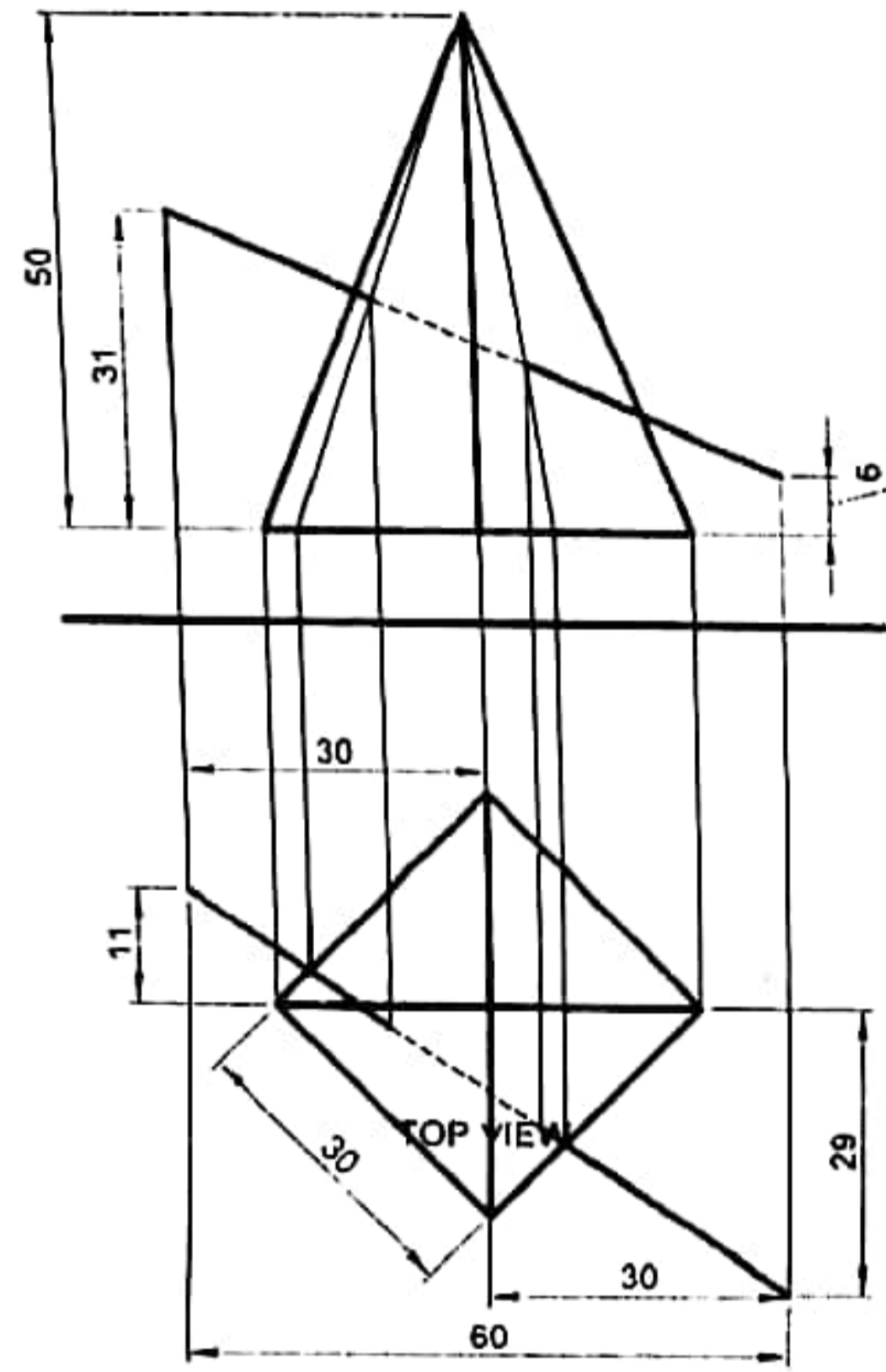

INTERSECTION BETWEEN SQUARE
BASE PYRAMID AND LINE

FRONT VIEW

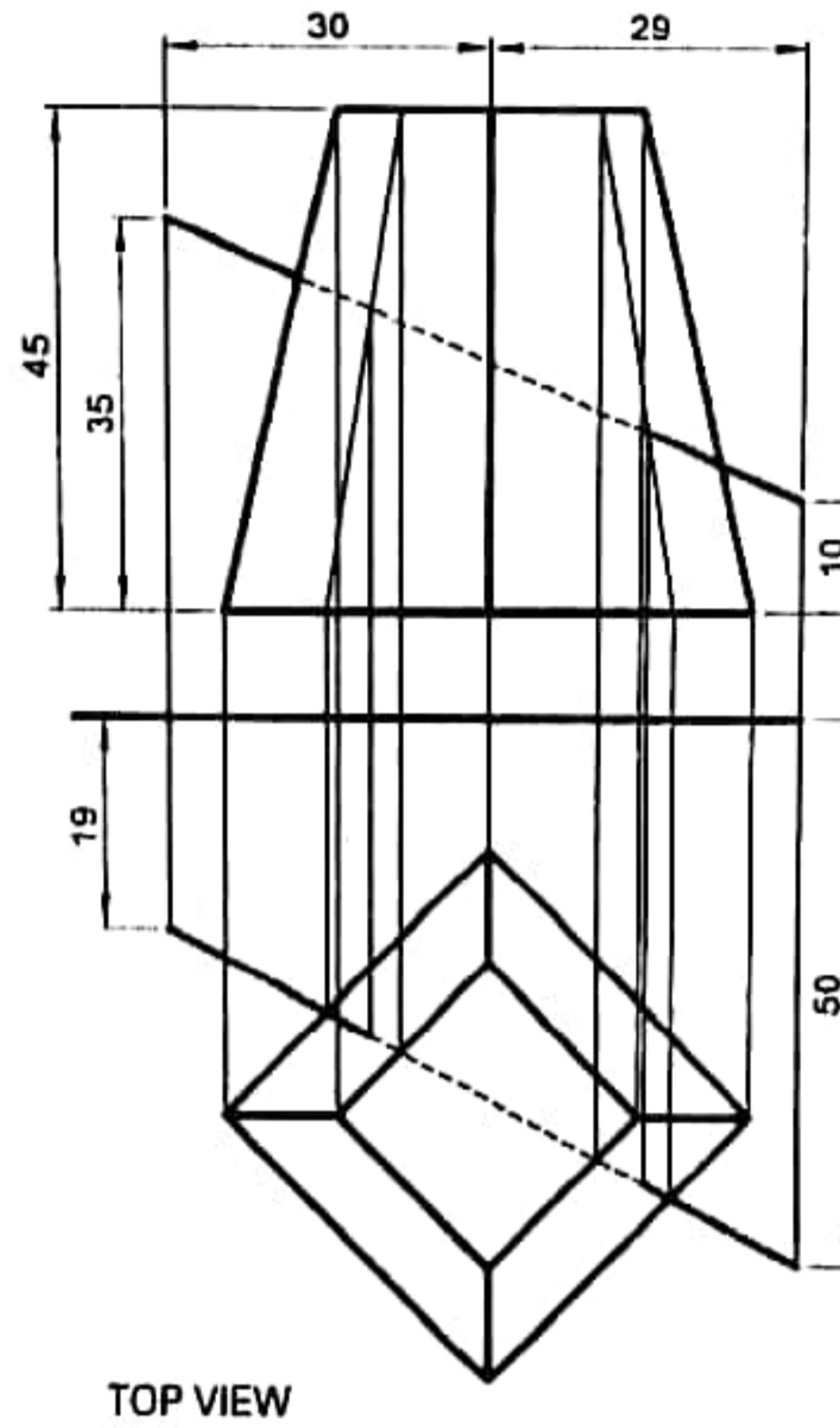

TOP VIEW

INTERSECTION BETWEEN
SQUARE BASE FRUSTUM
AND LINE

FRONT VIEW

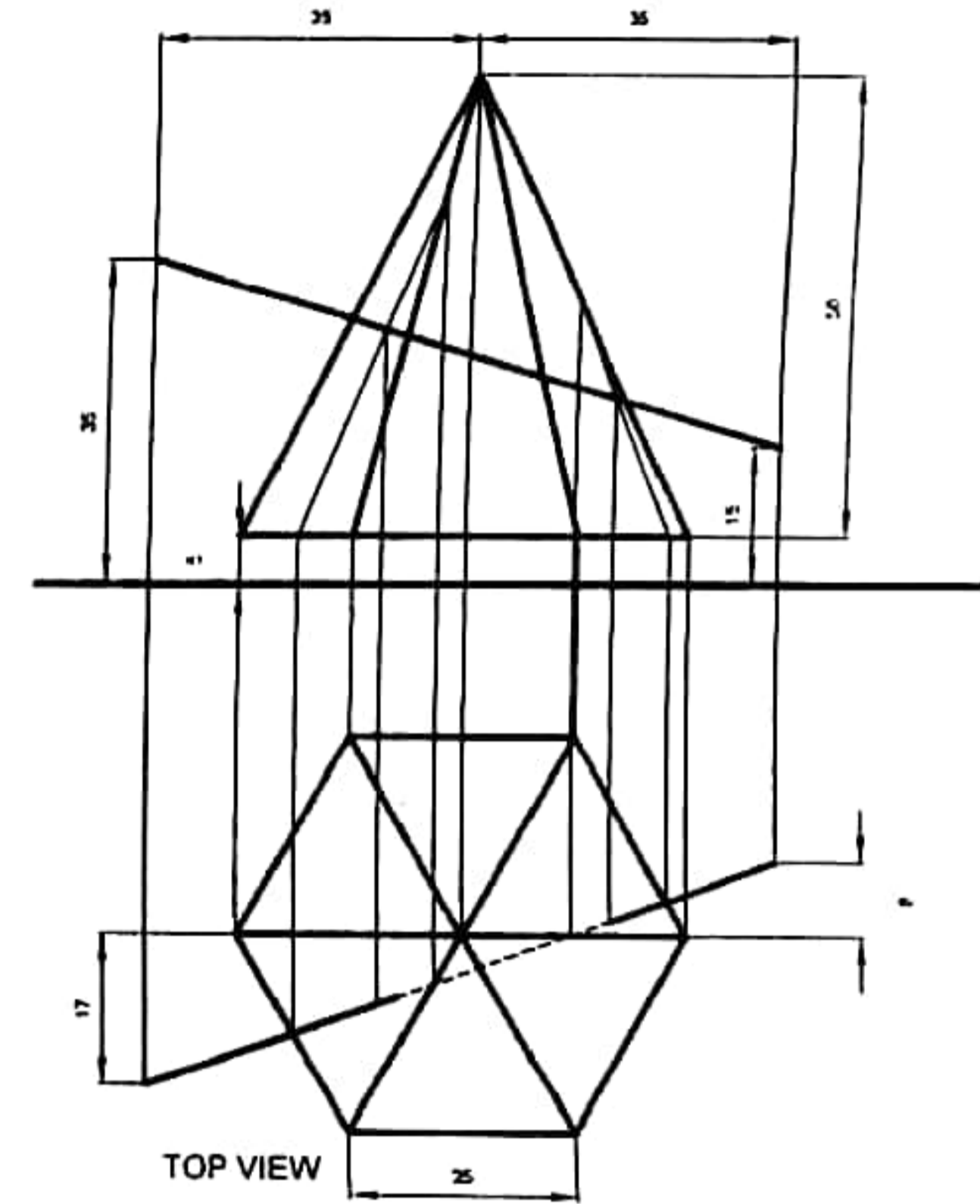

TOP VIEW

INTERSECTION BETWEEN
HEXAGONAL BASE
PYRAMID AND LINE

TOP VIEW

SUBJECT ENGINEERING DRAWING	TOPIC INTERSECTION BETWEEN LINE AND GEOMETRICAL SOLIDS	DRAWN BY NAME ROLL NO	CHECKED BY	DATE	SCALE
				DATE	DRAWING NO DG-13

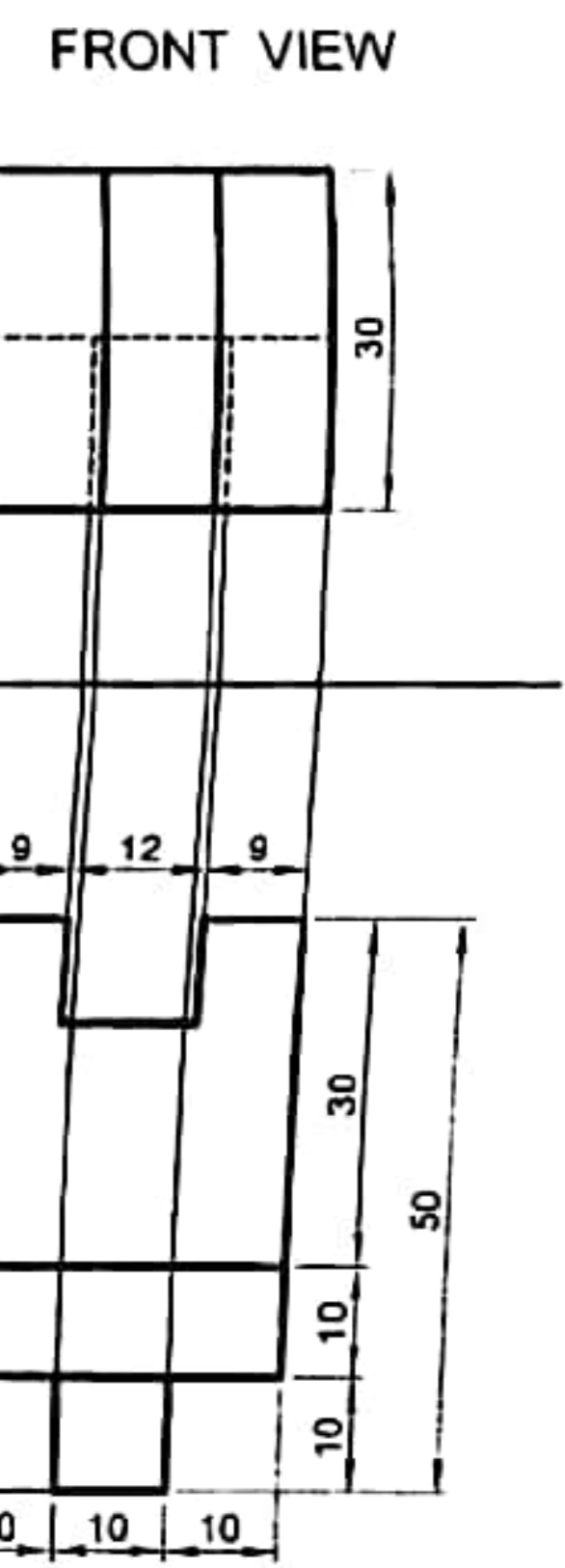
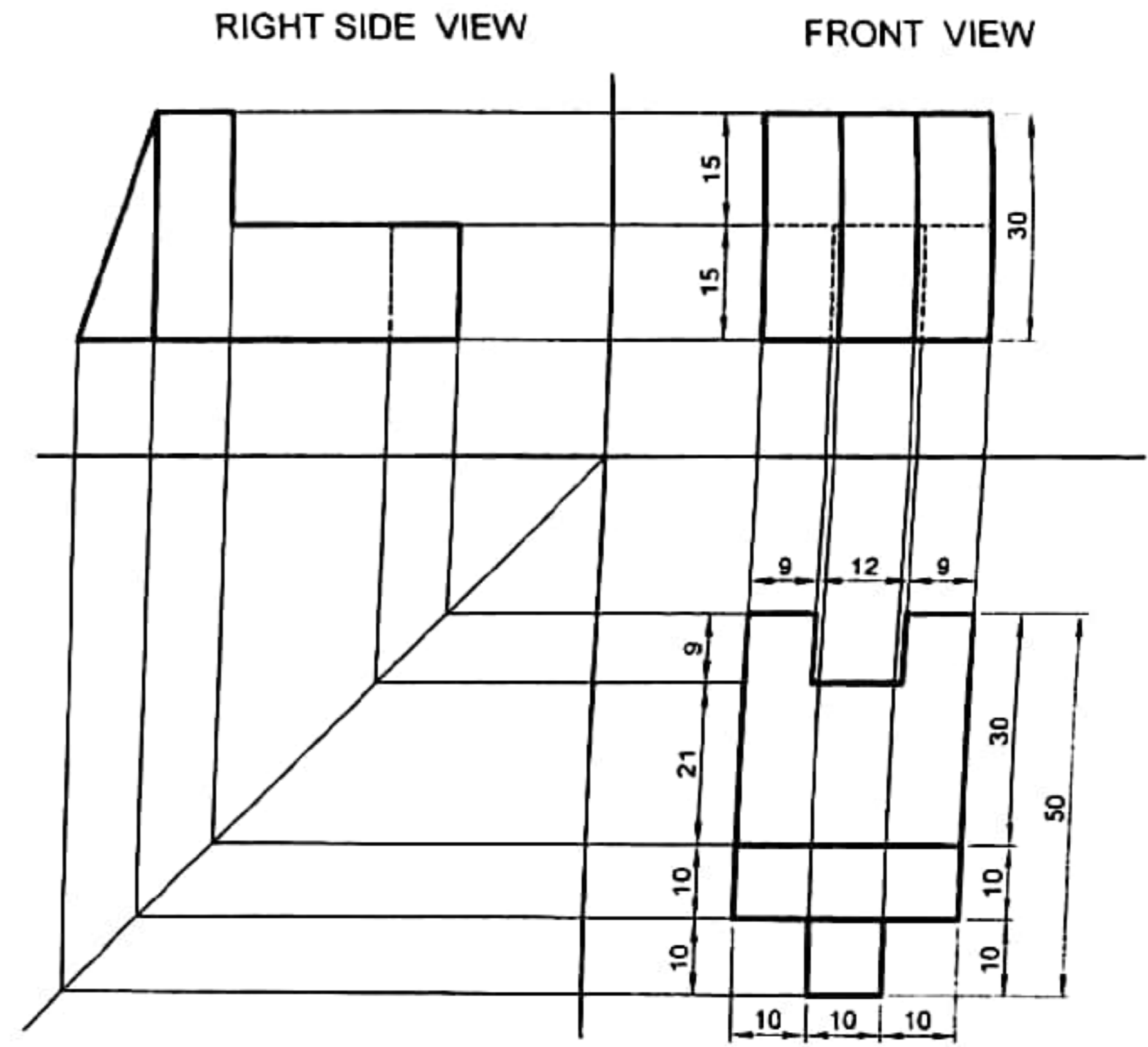
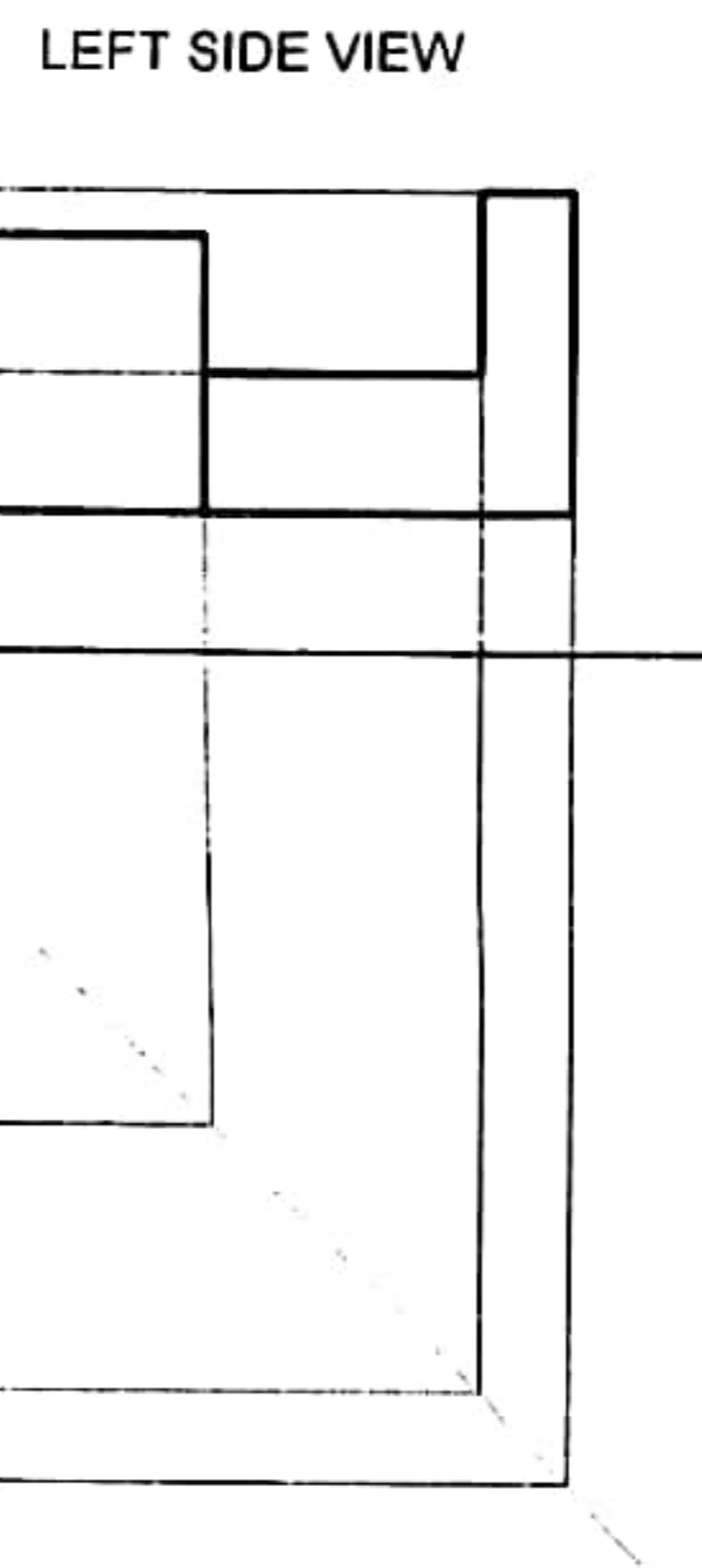
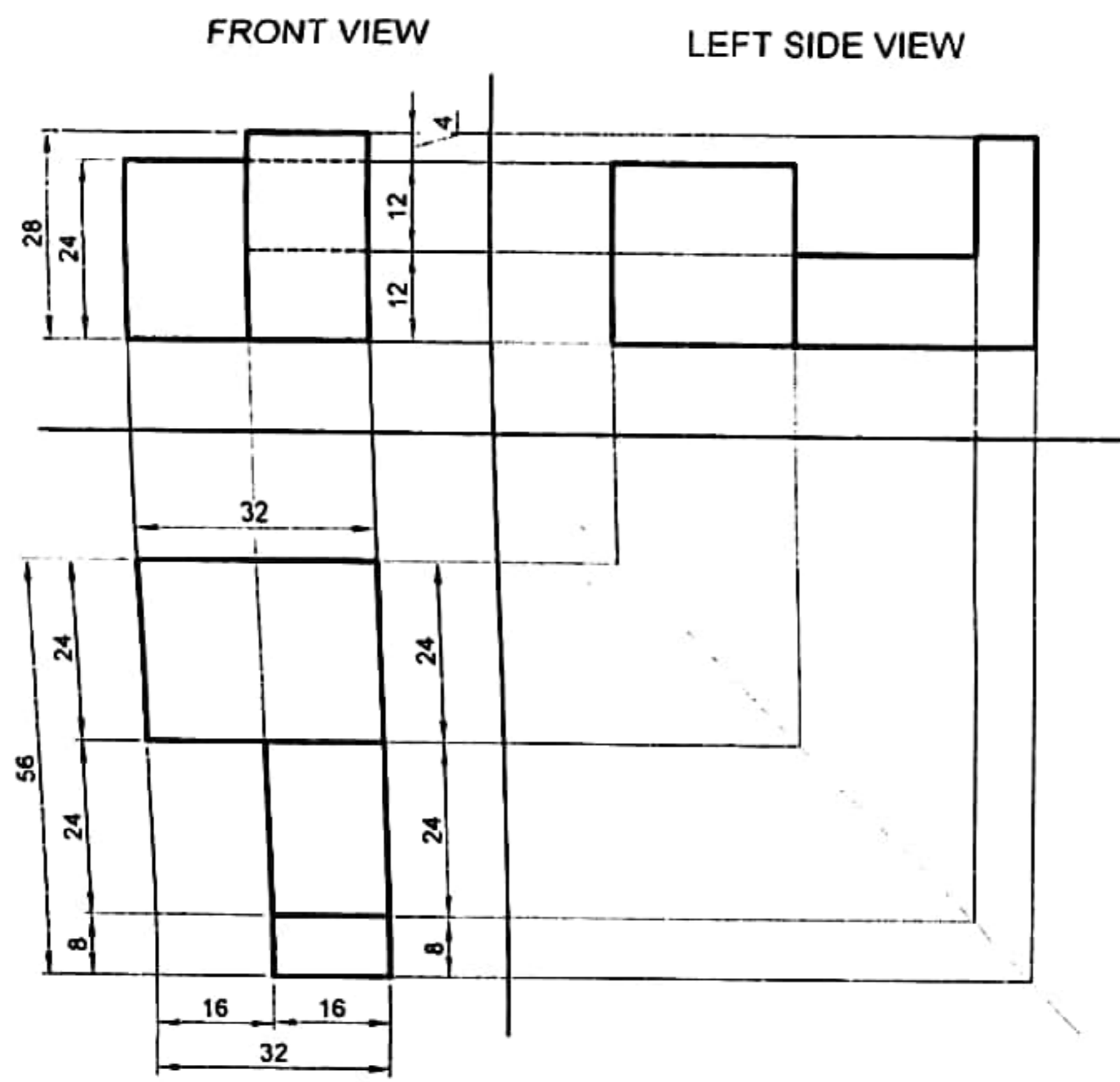

TOP VIEW

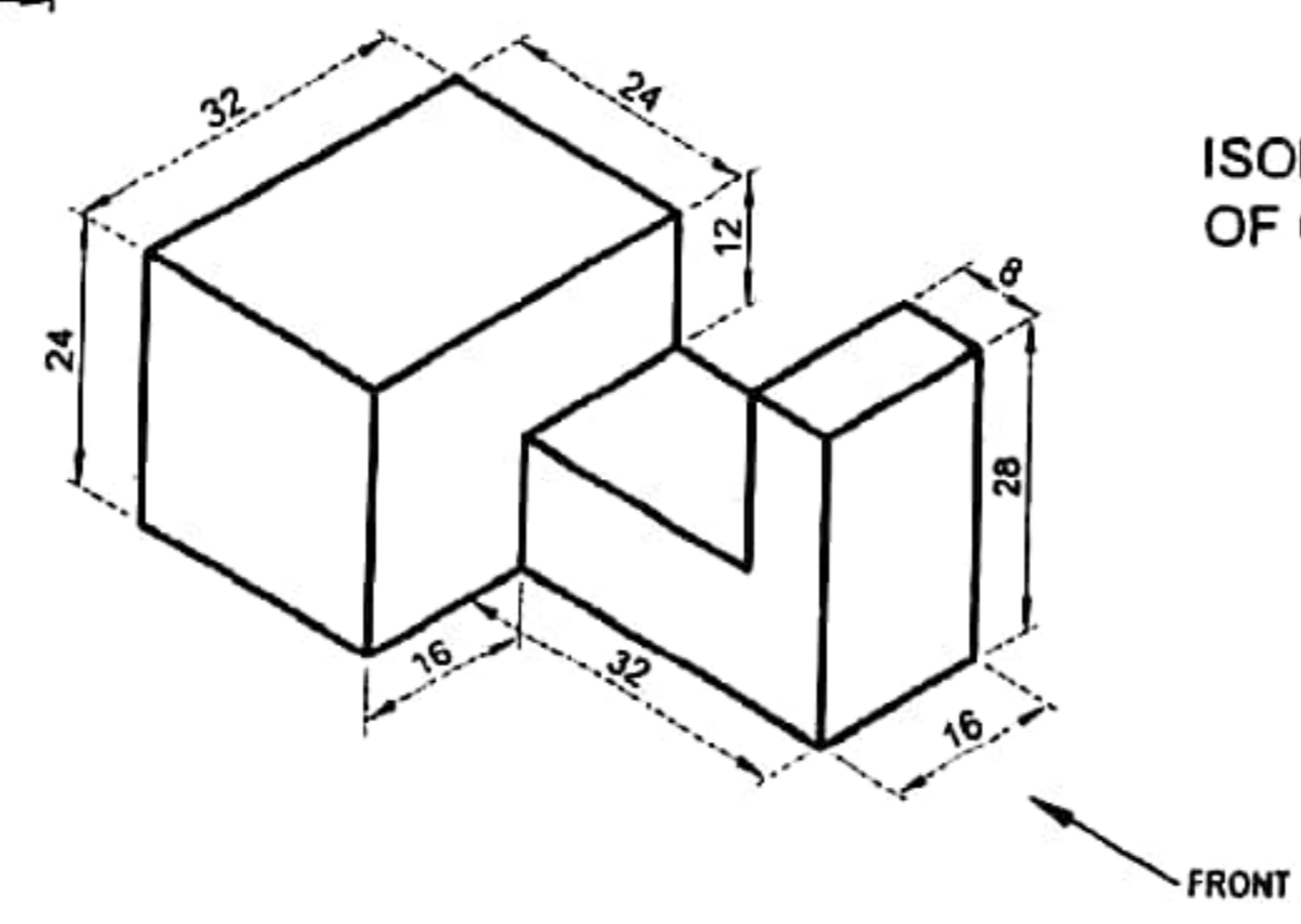

ISOMETRIC VIEW OF GIVEN SOLID

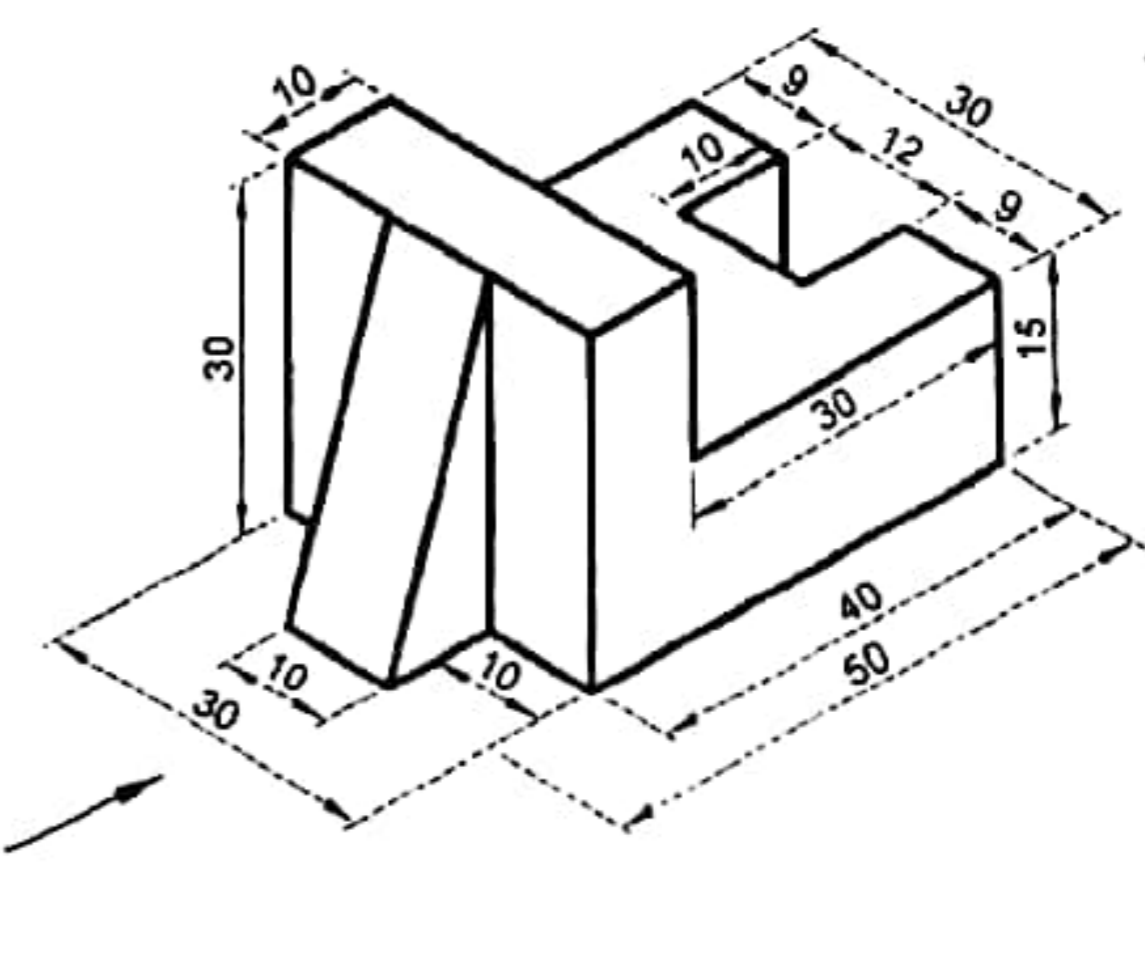

TOP VIEW

	SUBJECT	TOPIC	DRAWN BY	CHECKED BY	DATE	SCALE
	ENGINEERING DRAWING	ORTHOGRAPHIC PROJECTION PROJECTION OF SOLIDS (First angle projection)	NAME ROLL NO			
				DATE	DRAWING NO	
					OP-1	

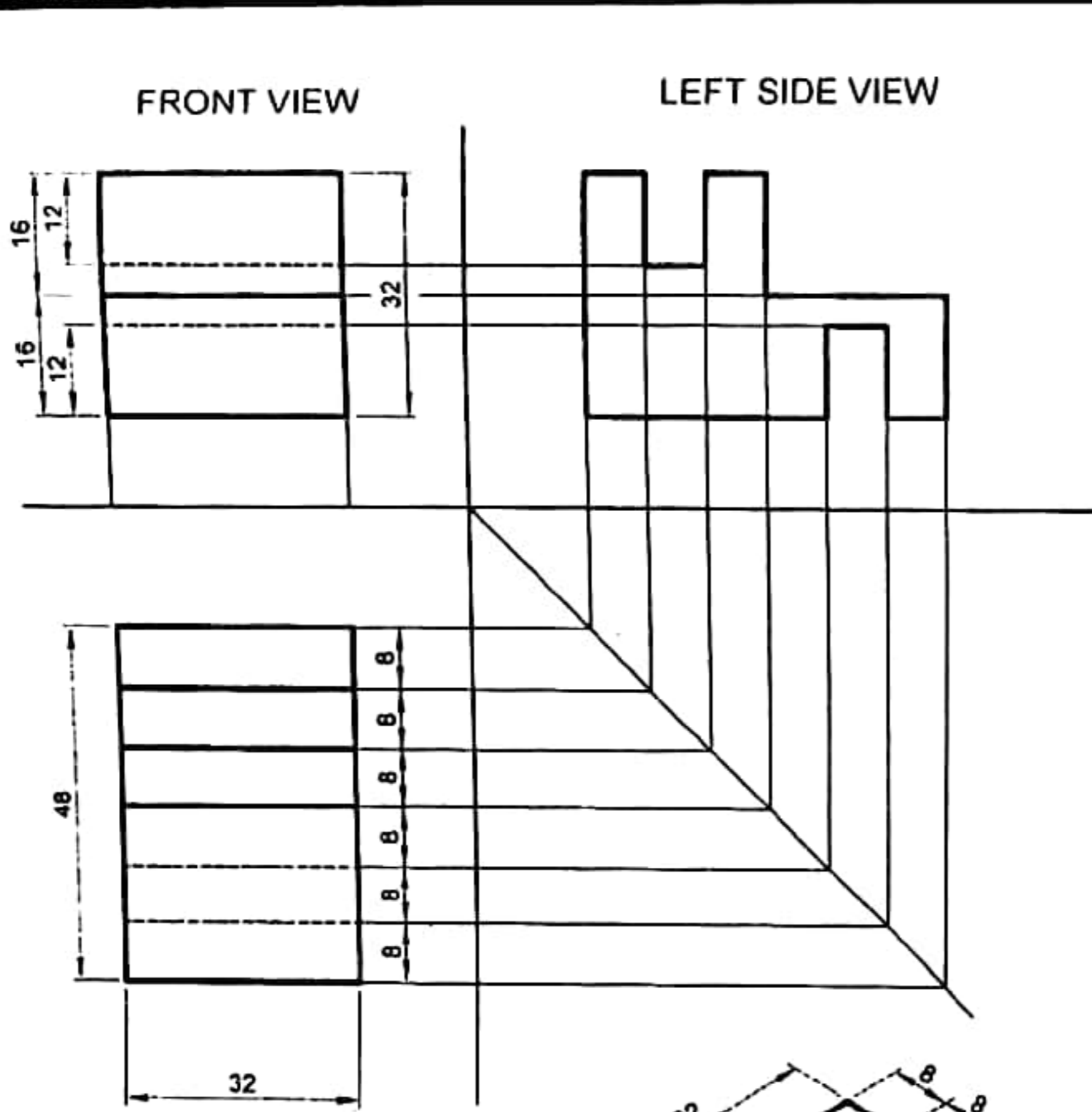

TOP VIEW

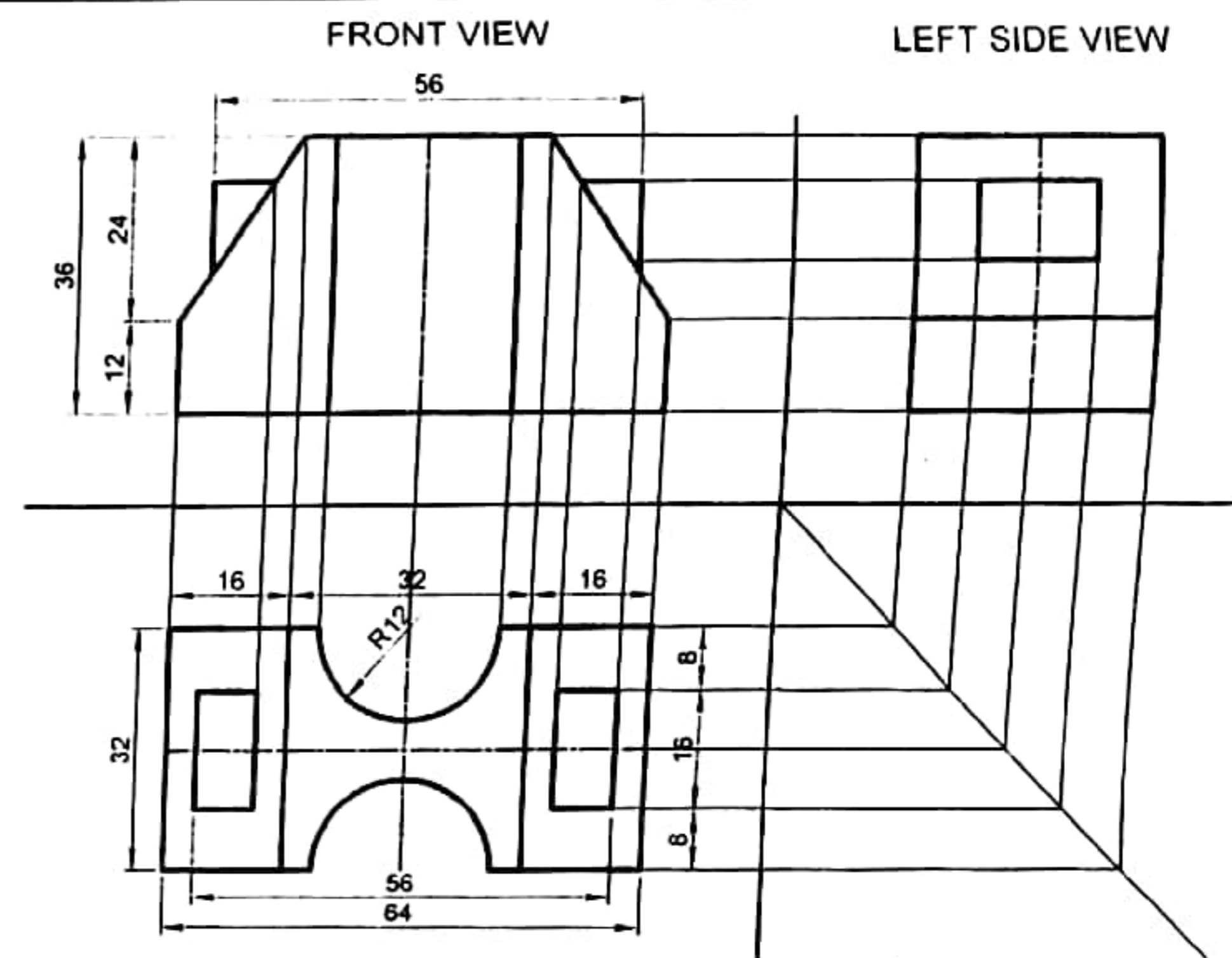
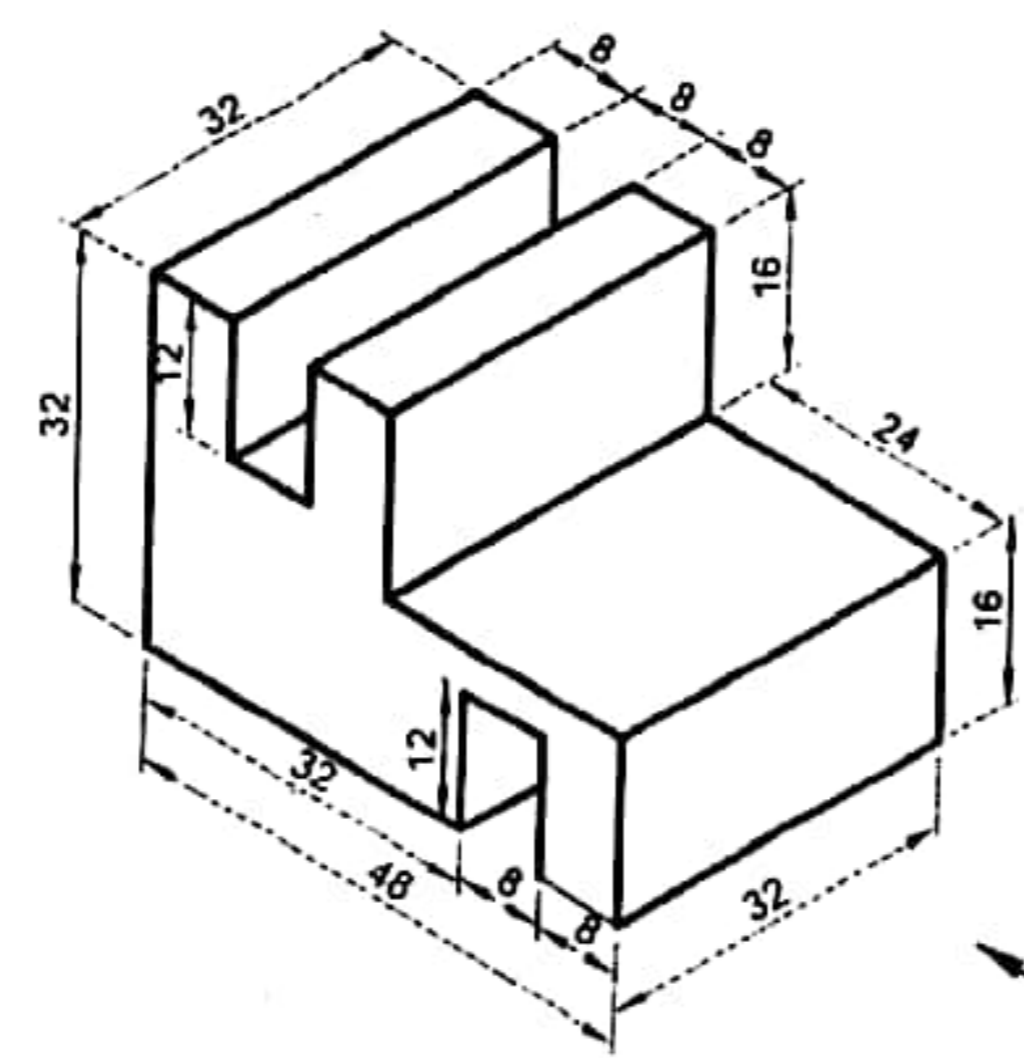

TOP VIEW

ISOMETRIC VIEW OF GIVEN SOLID

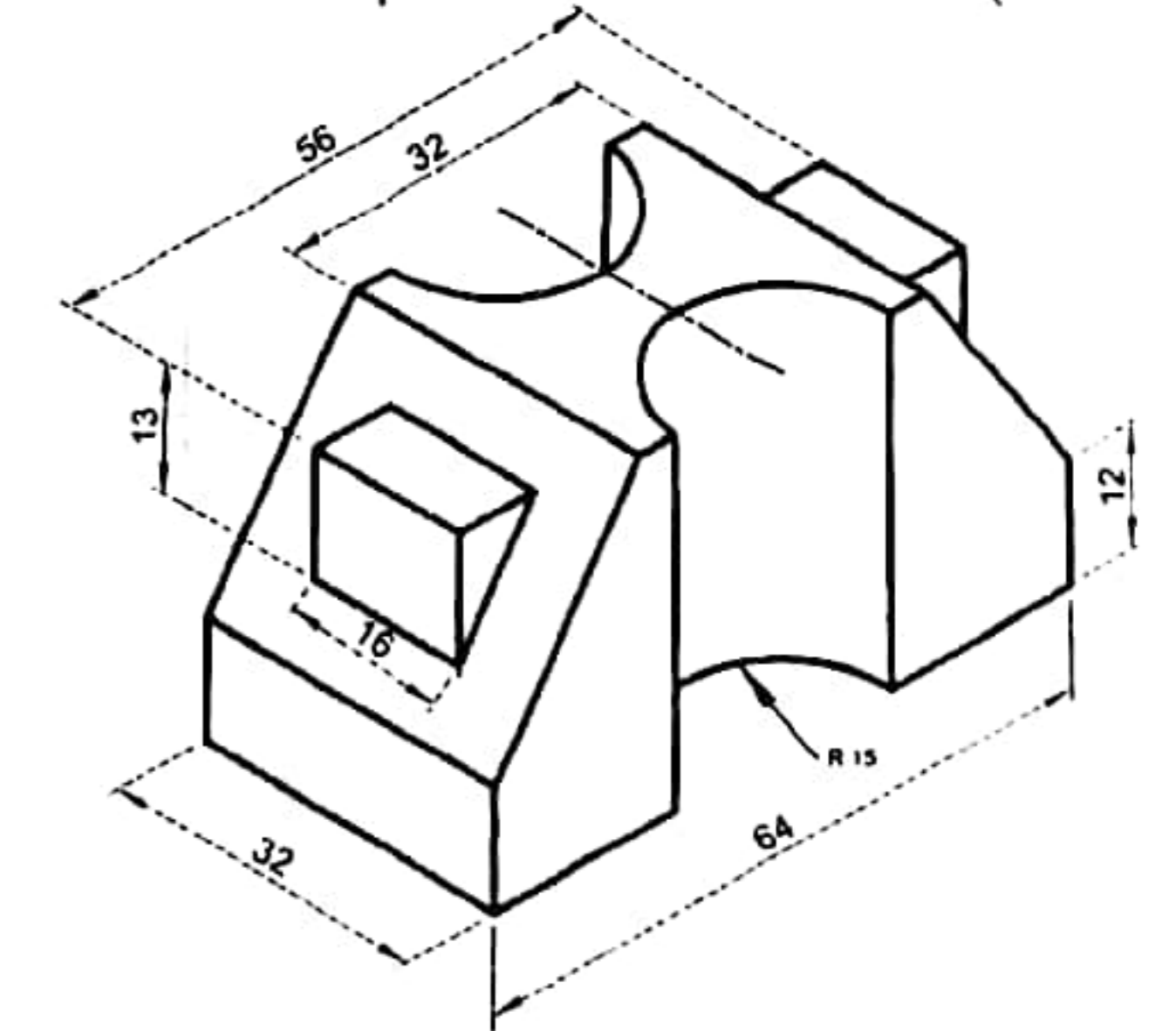

	SUBJECT	TITLE	DRAWN BY	CHECKED BY	DATE	SCALE
	ENGINEERING DRAWING	ORTHOGRAPHIC PROJECTION PROJECTION OF SOLIDS (First angle projection)	NAME ROLL NO			
				DATE	DRAWING NO	
						OP-2

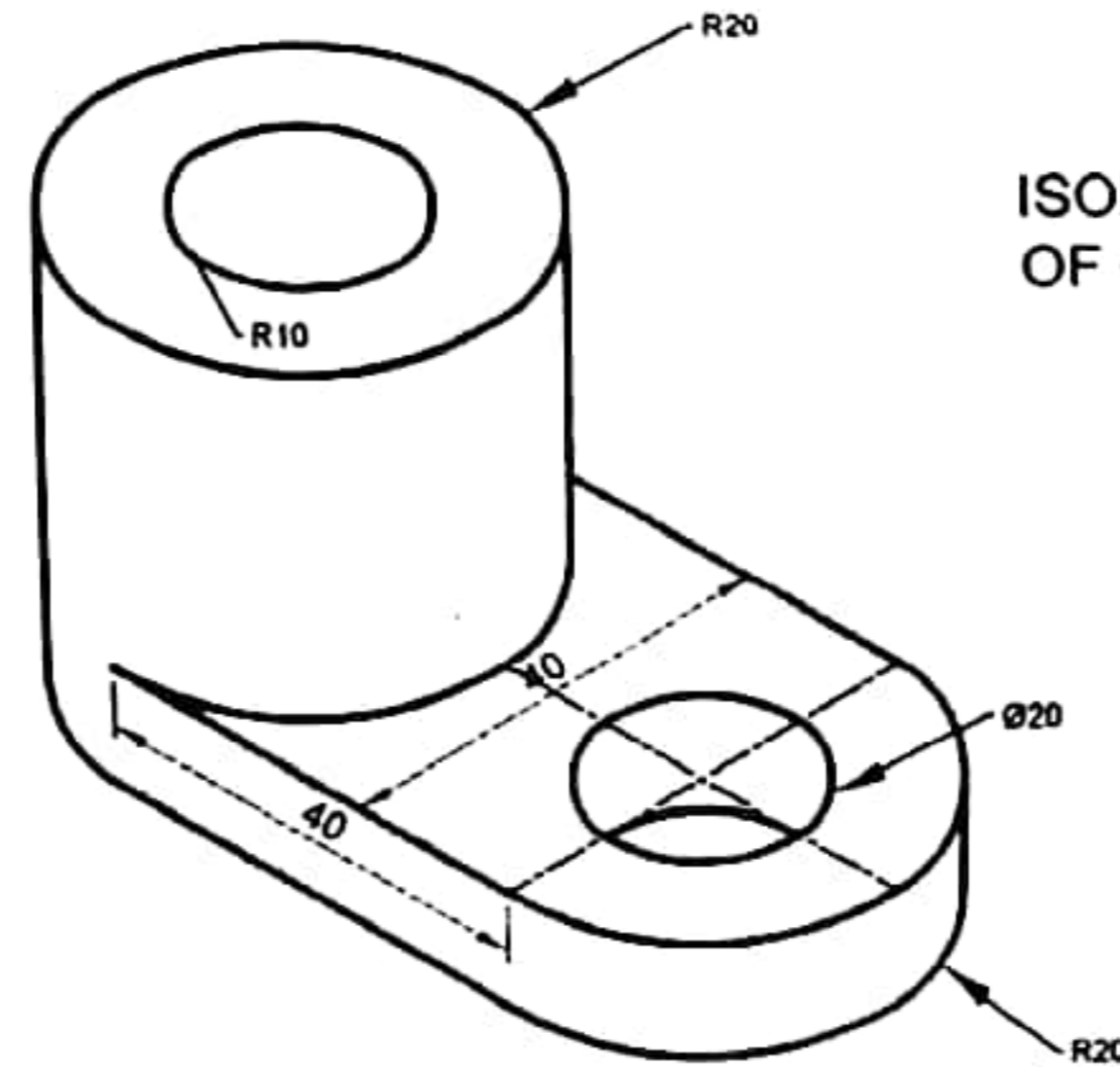

ISOMETRIC VIEW OF GIVEN SOLID

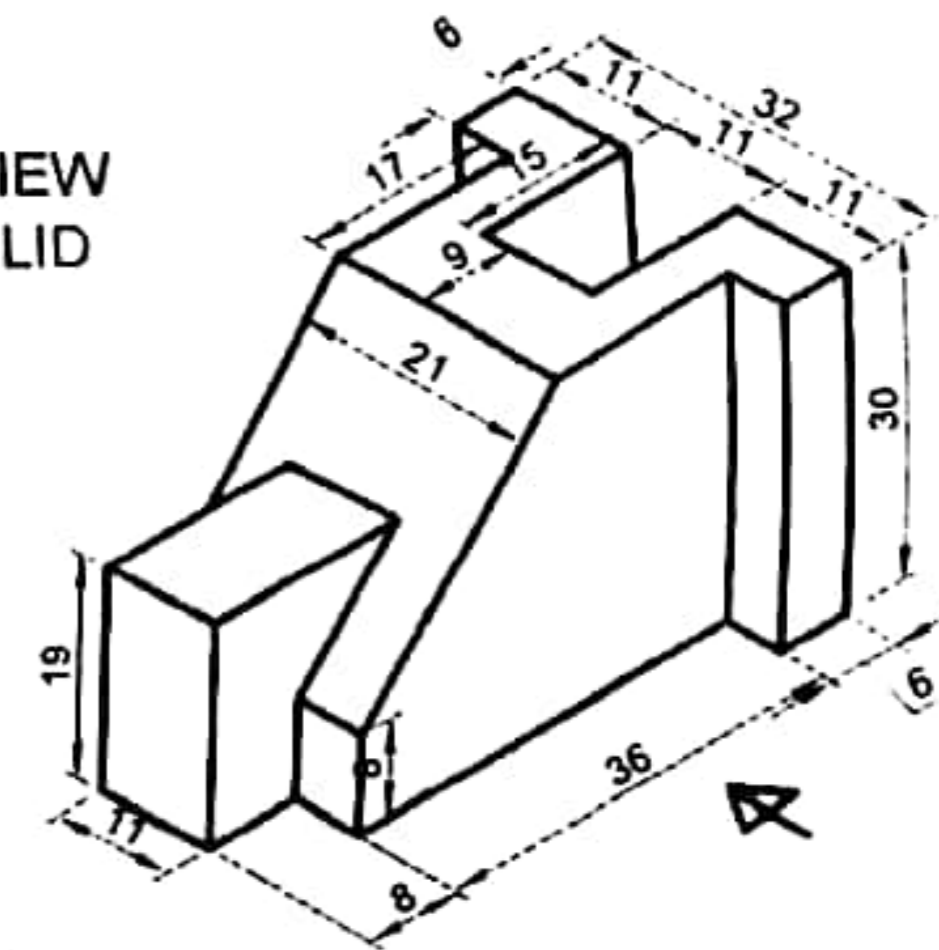

FRONT VIEW

LEFT SIDE VIEW

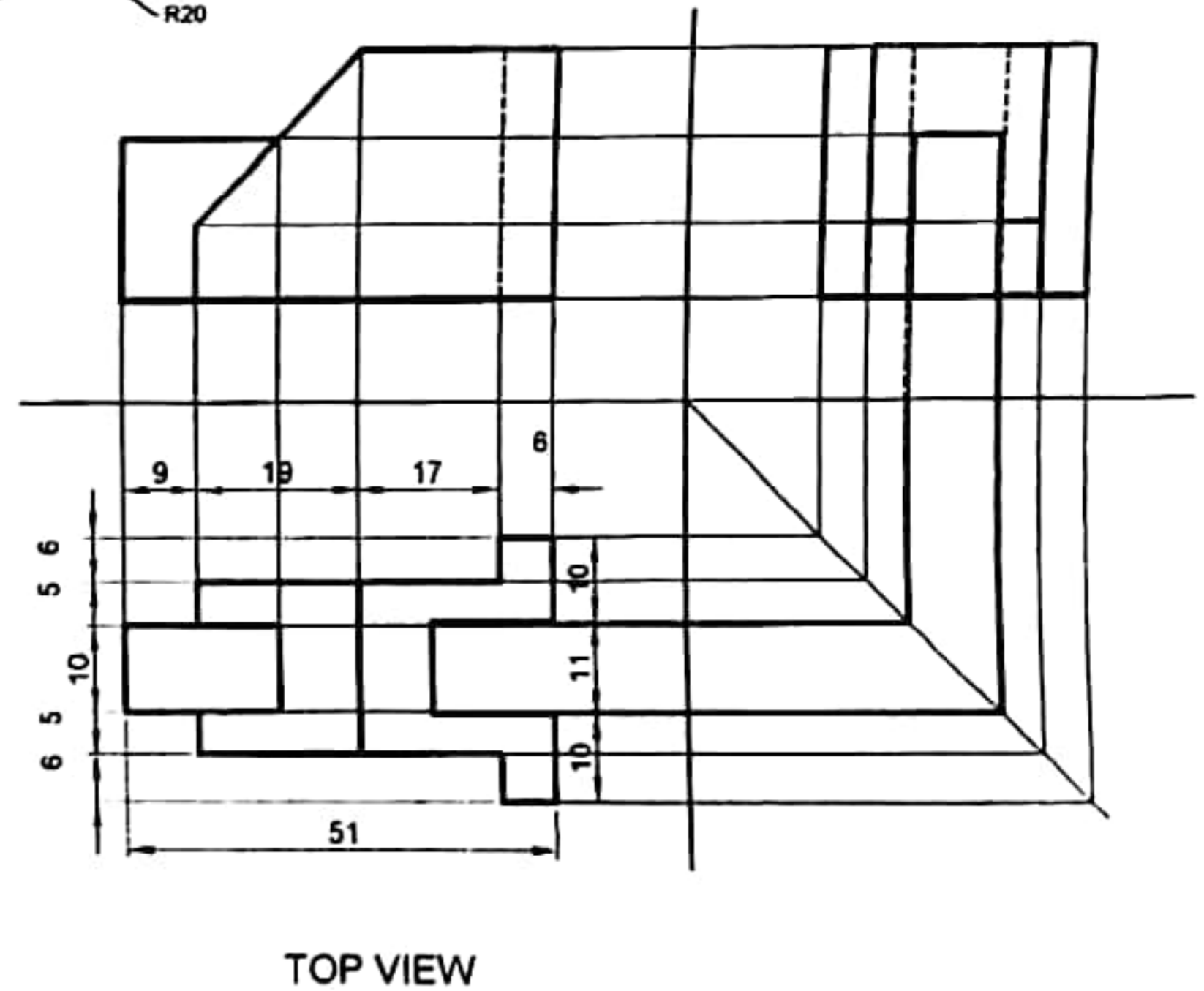
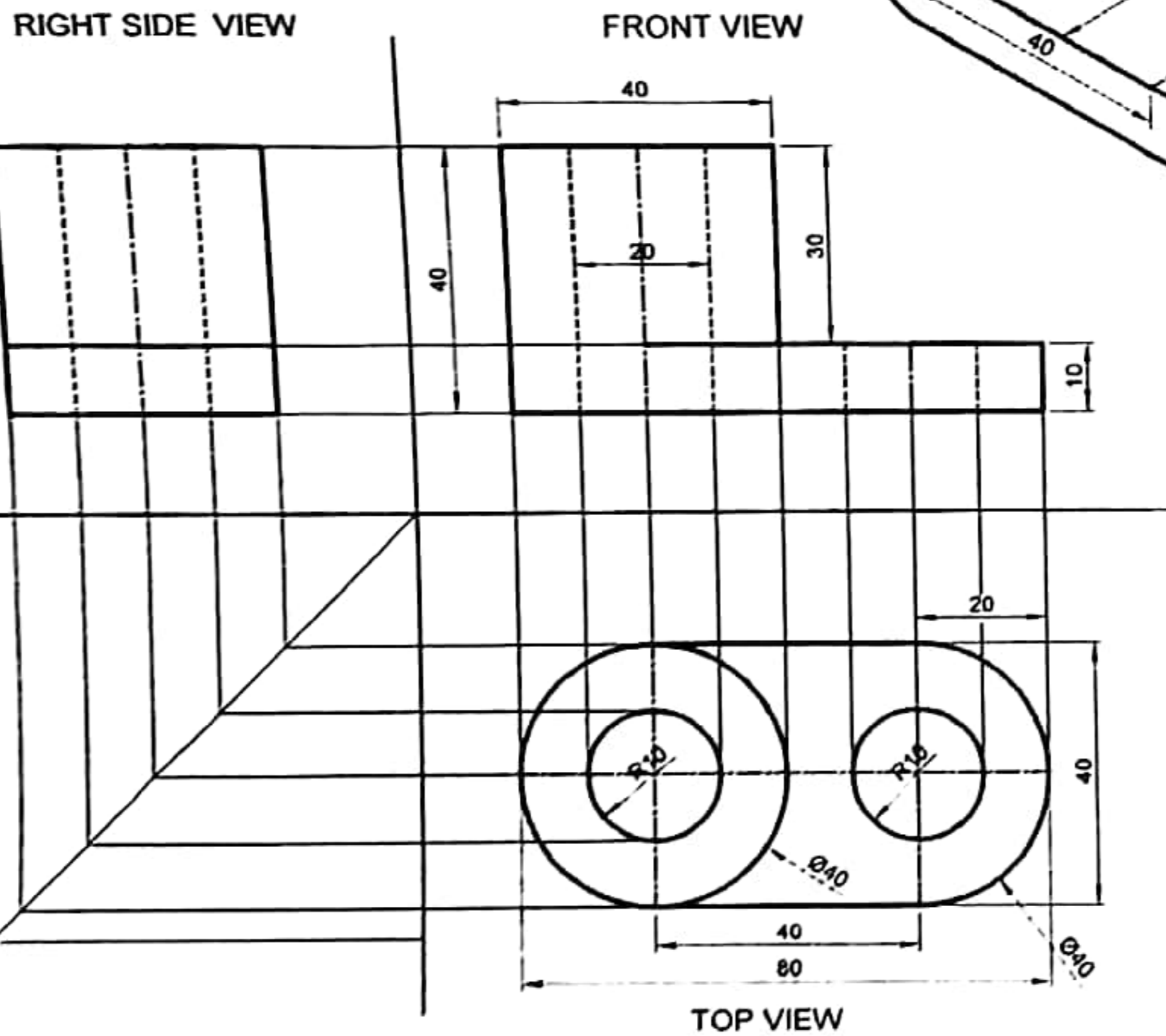

TOP VIEW

	SUBJECT	TITLE	DRAWN BY	CHECKED BY	DATE	SCALE
	ENGINEERING DRAWING	ORTHOGRAPHIC PROJECTION PROJECTION OF SOLIDS (First angle projection)	NAME ROLL NO			
				DATE	DRAWING NO	OP-3

RIGHT SIDE VIEW

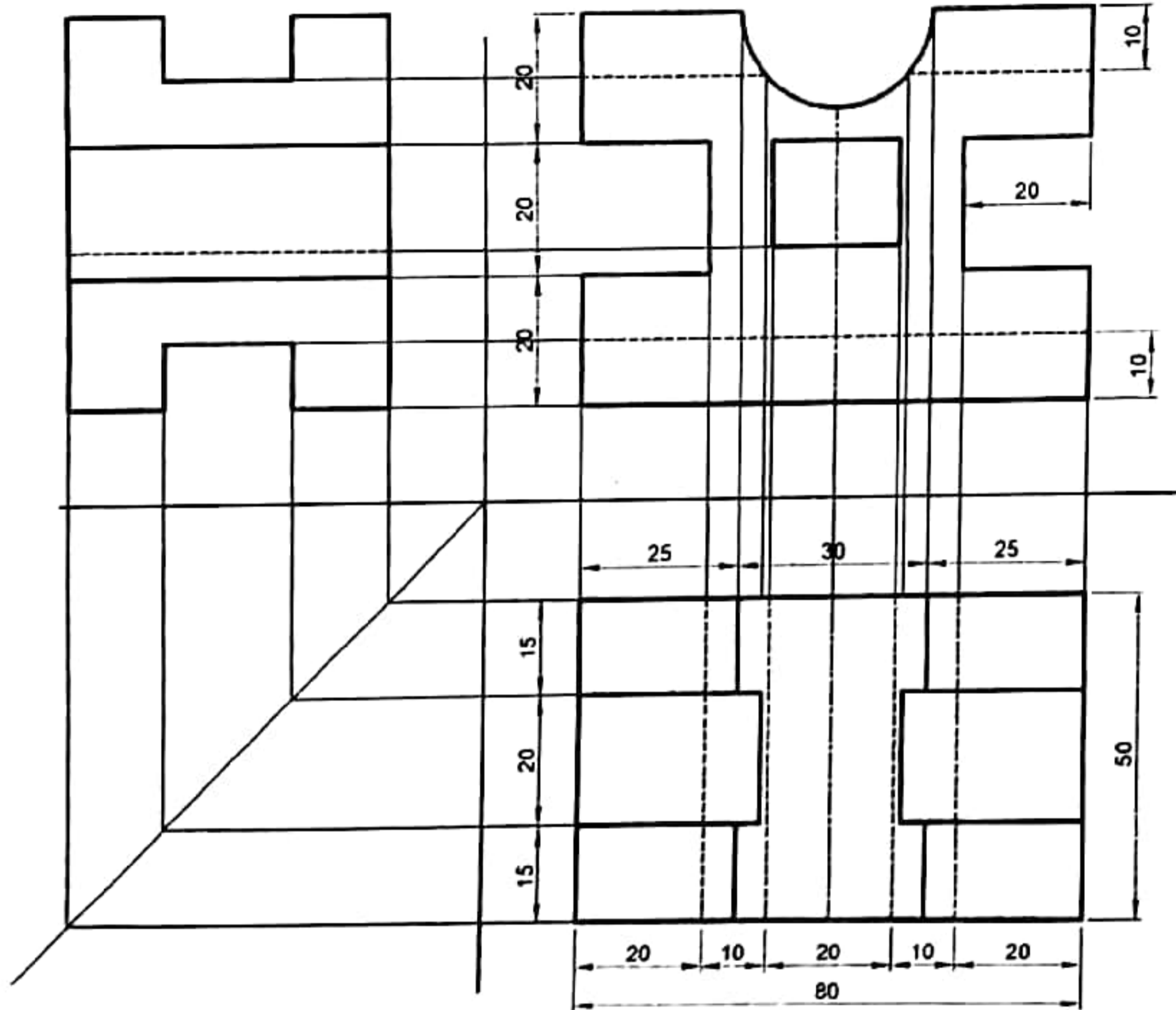

FRONT VIEW

ISOMETRIC VIEW OF GIVEN SOLID

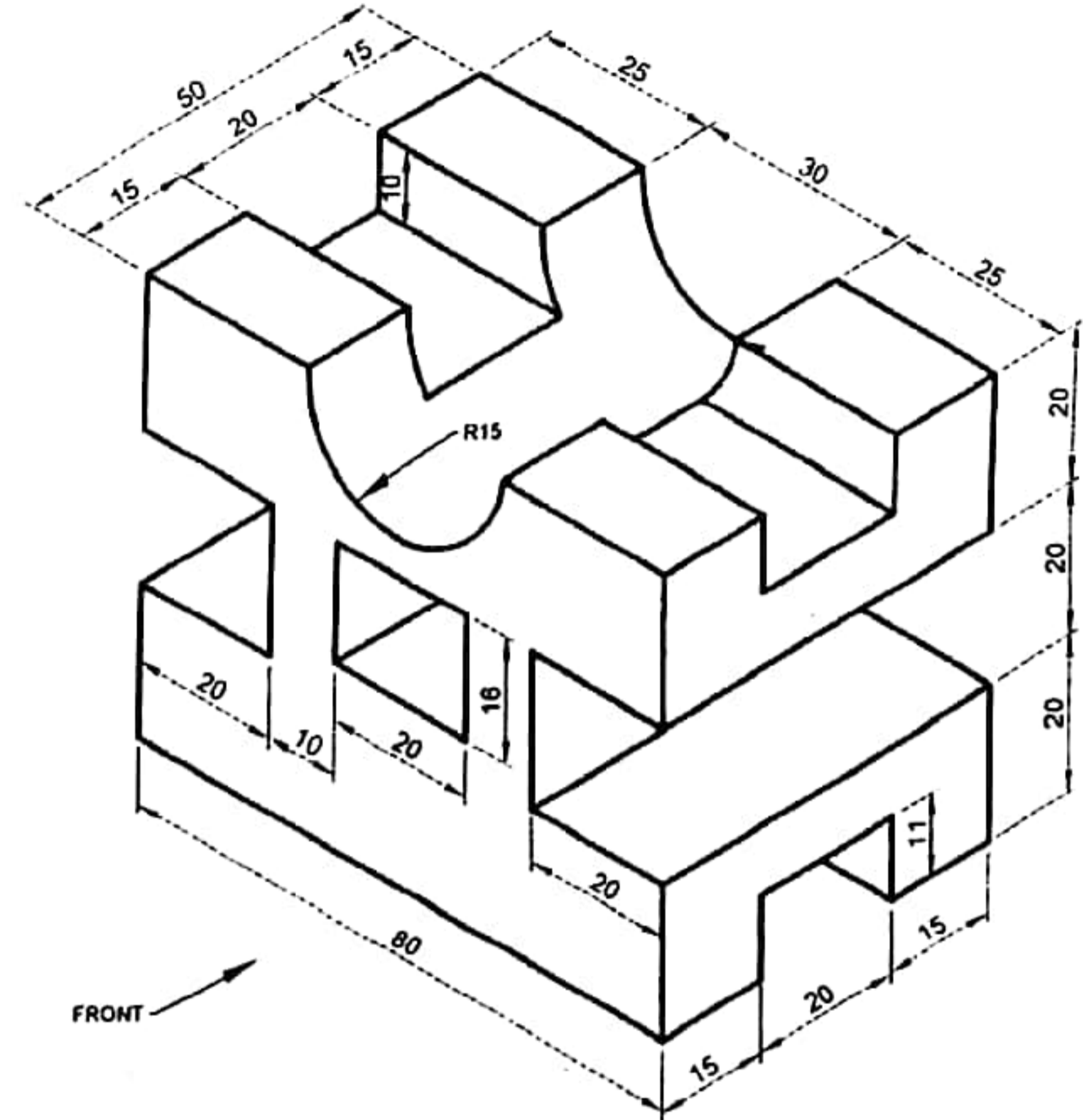

TOP VIEW

	SUBJECT	TITLE	DRAWN BY	CHECKED BY	DATE	SCALE
	ENGINEERING DRAWING	ORTHOGRAPHIC PROJECTION PROJECTION OF SOLIDS (First angle projection)	NAME ROLL NO	DATE	DRAWING NO	OP-4

COLLECTION AND PREPARED BY NARESH DEVI...

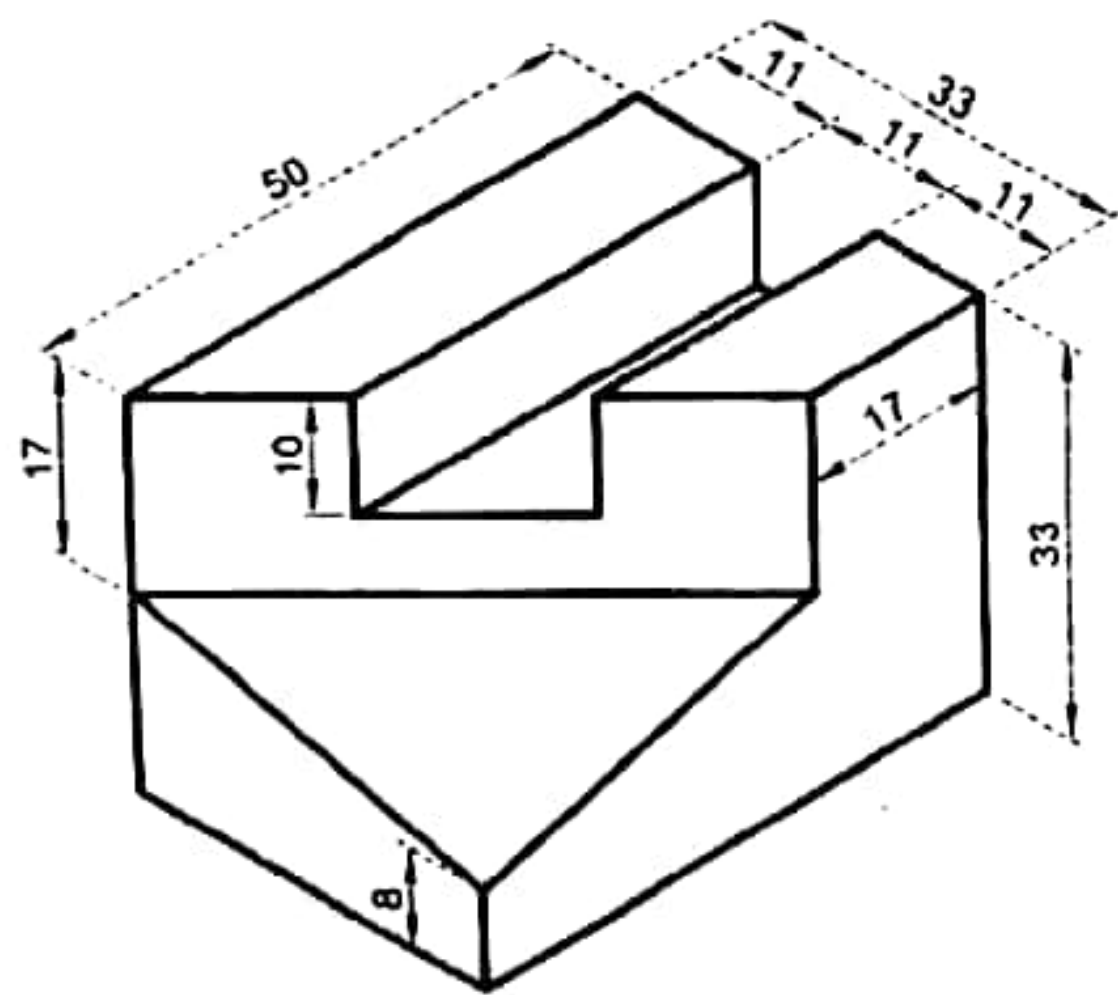

ISOMETRIC VIEW OF GIVEN SOLID

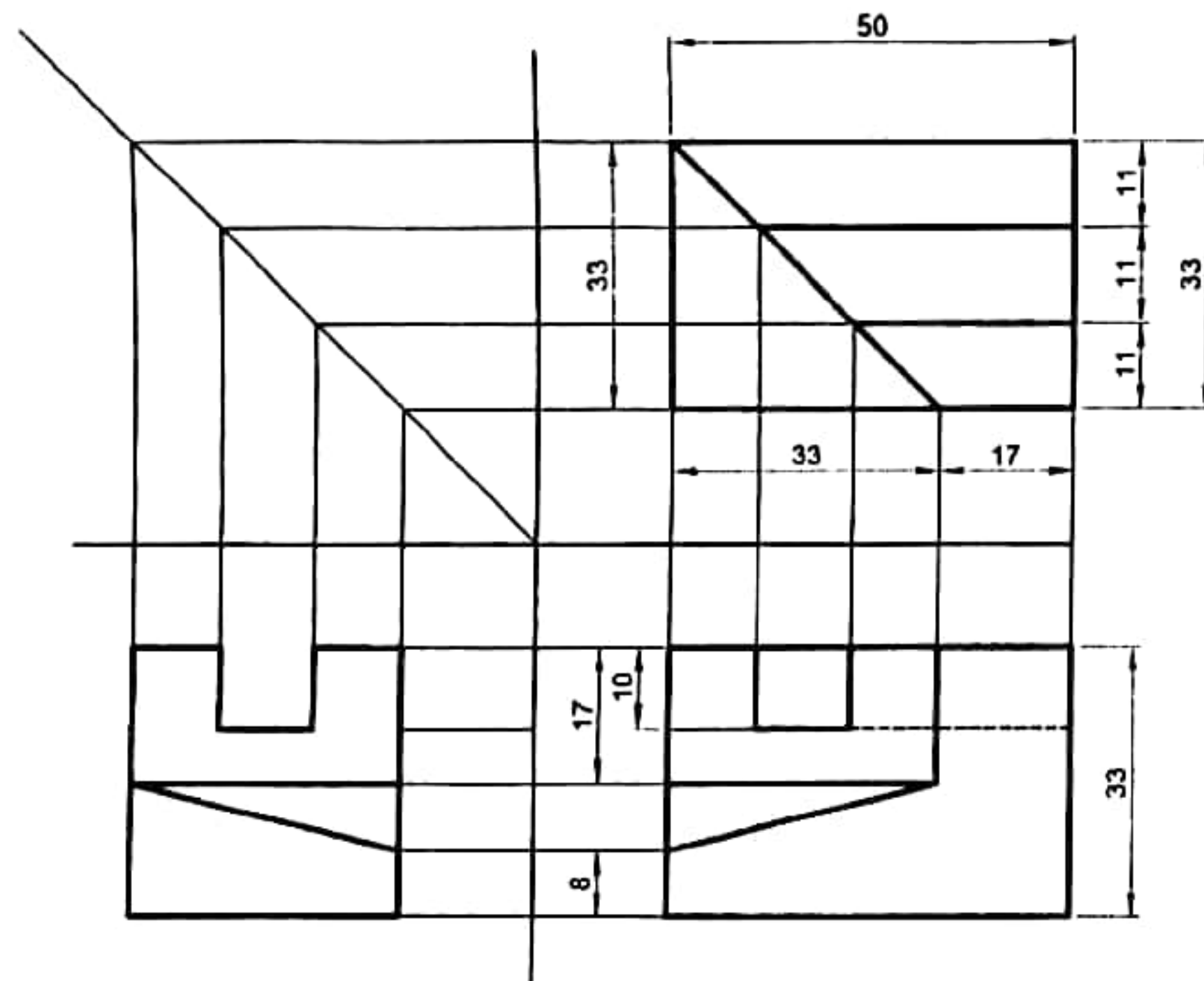
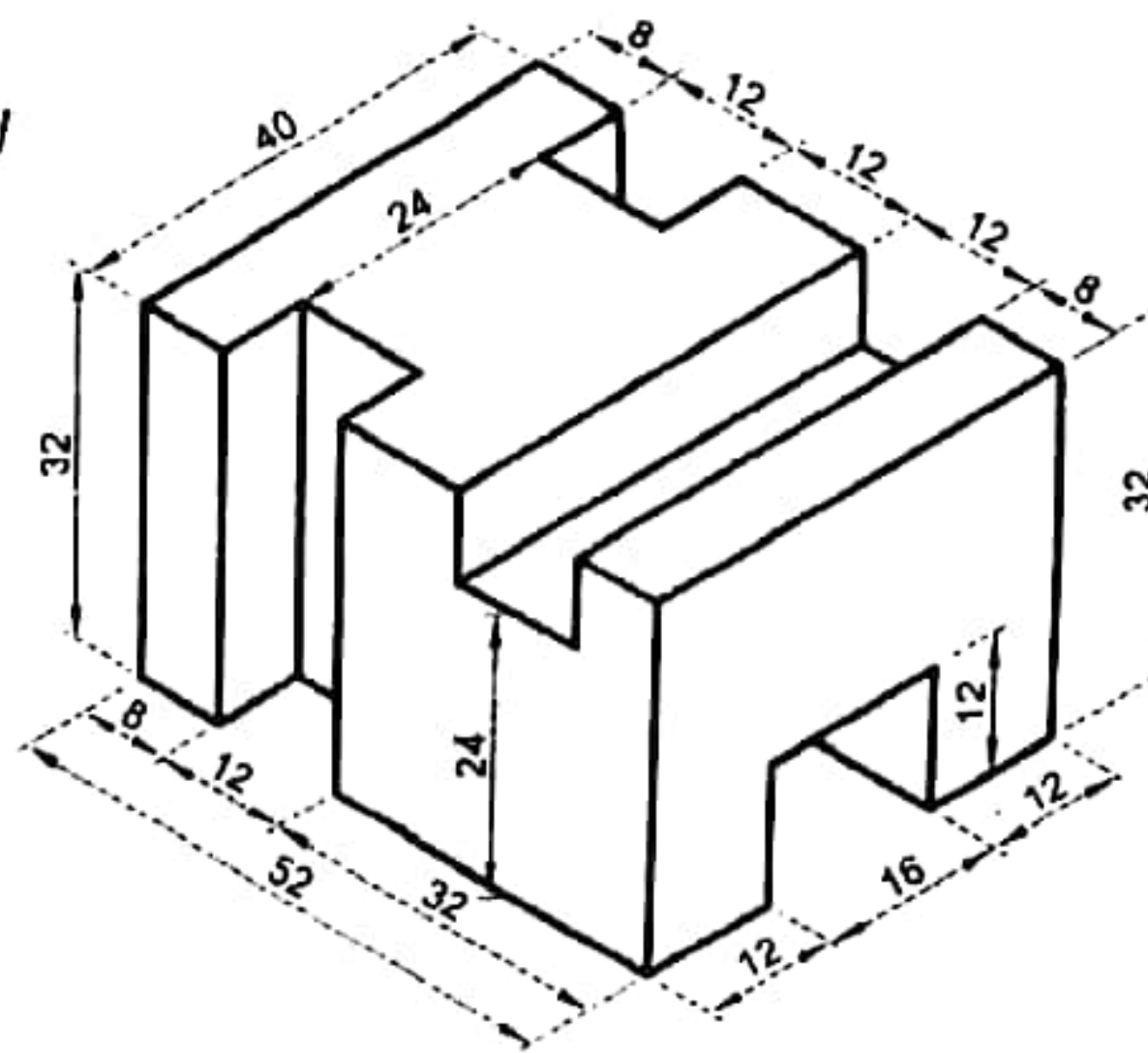

LEFT SIDE VIEW

FRONT VIEW

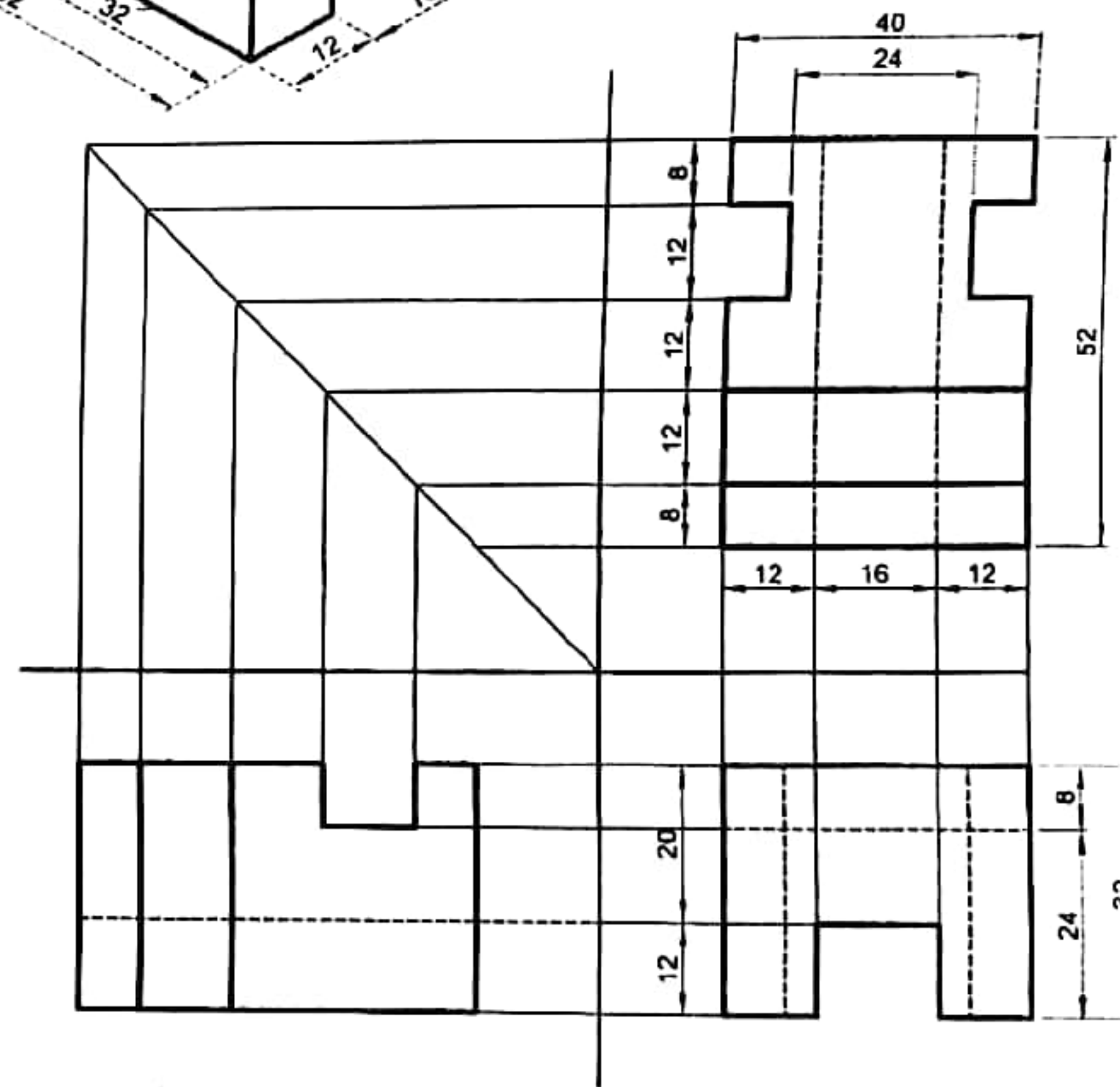

LEFT SIDE VIEW

FRONT VIEW

	SUBJECT	TITLE	DRAWN BY	CHECKED BY	DATE	SCALE
	ENGINEERING DRAWING	ORTHOGRAPHIC PROJECTION OF SOLIDS (Third angle projection)	NAME ROLL NO			
				DATE	DRAWING NO OP-5	

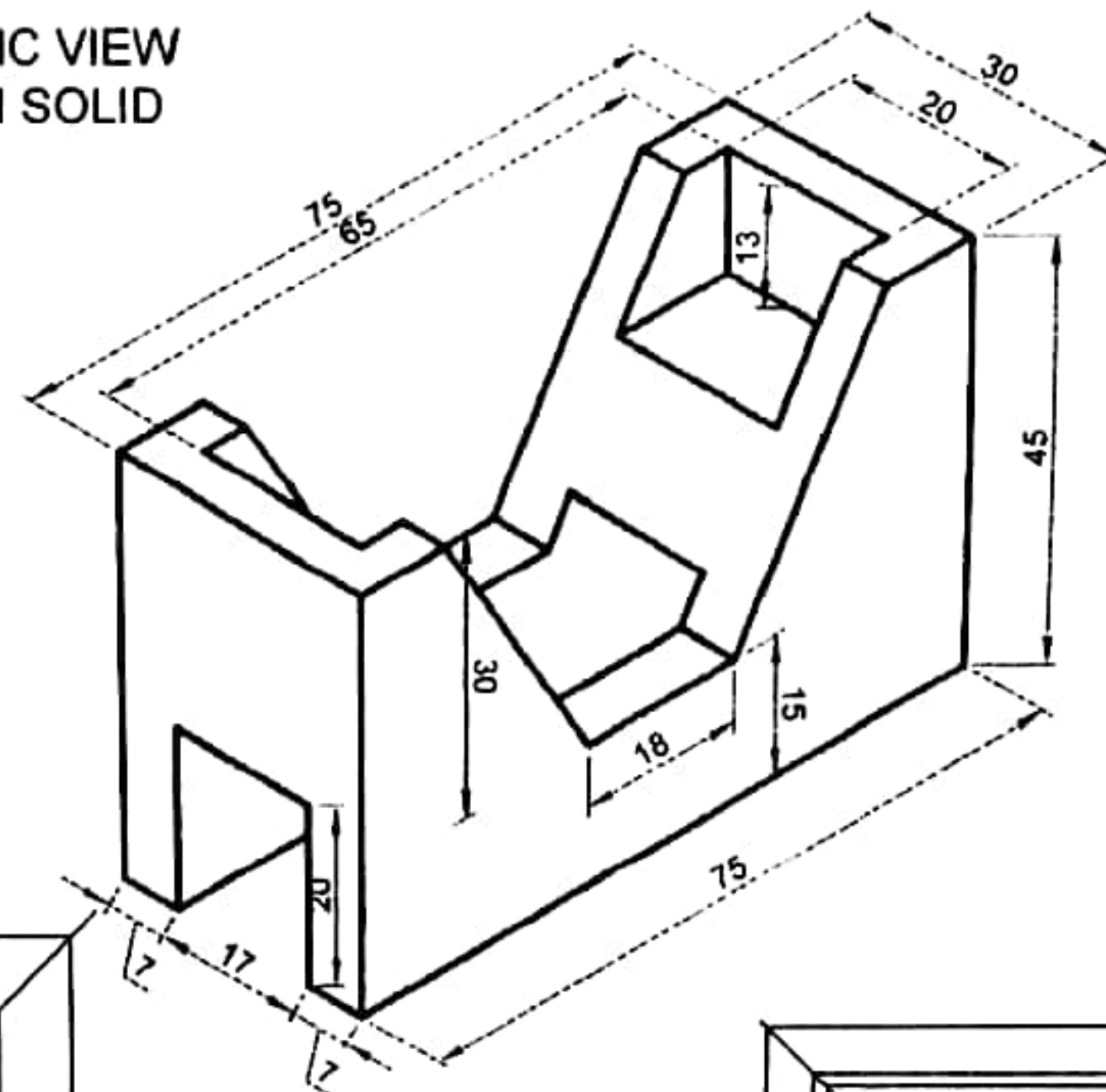
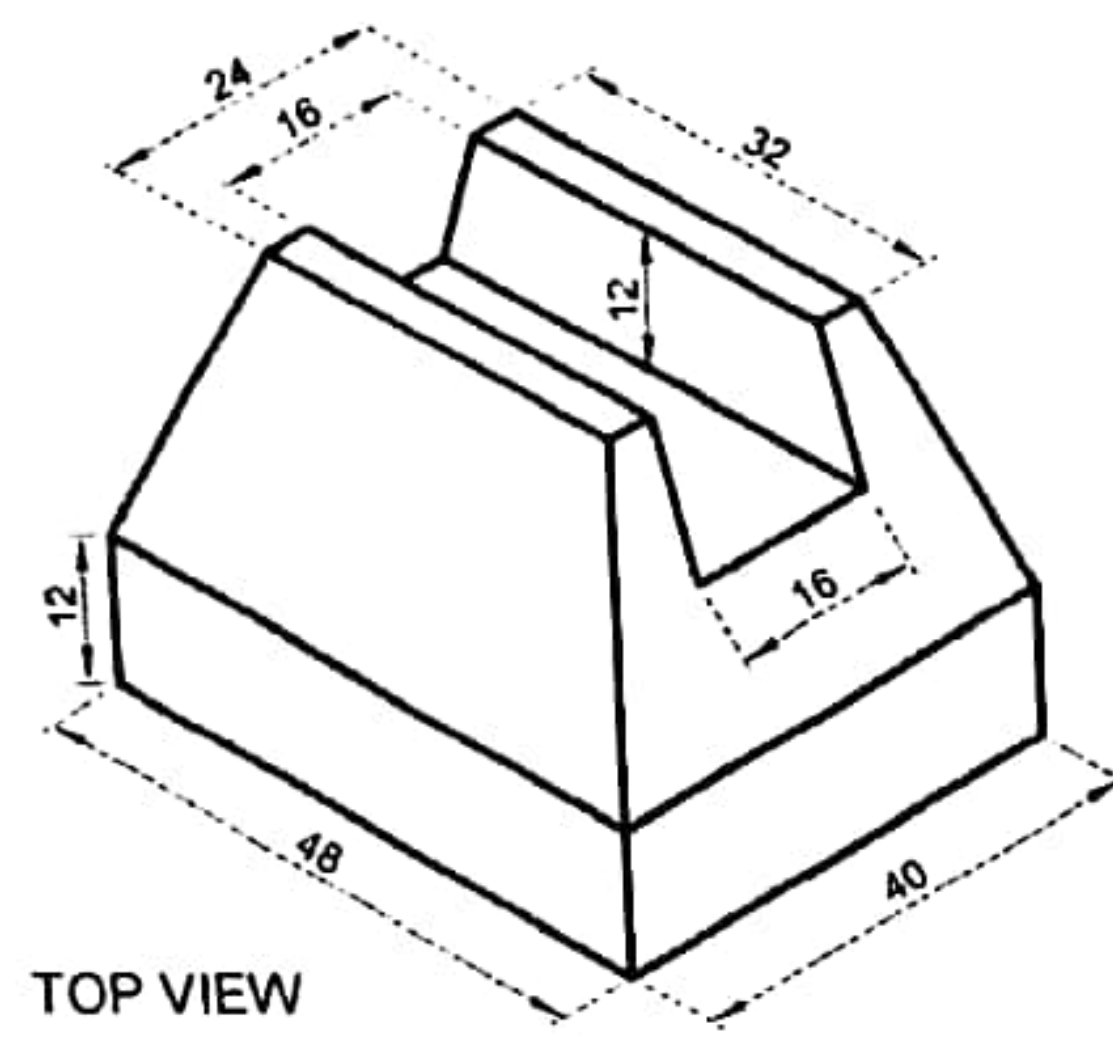

TOP VIEW

TOP VIEW

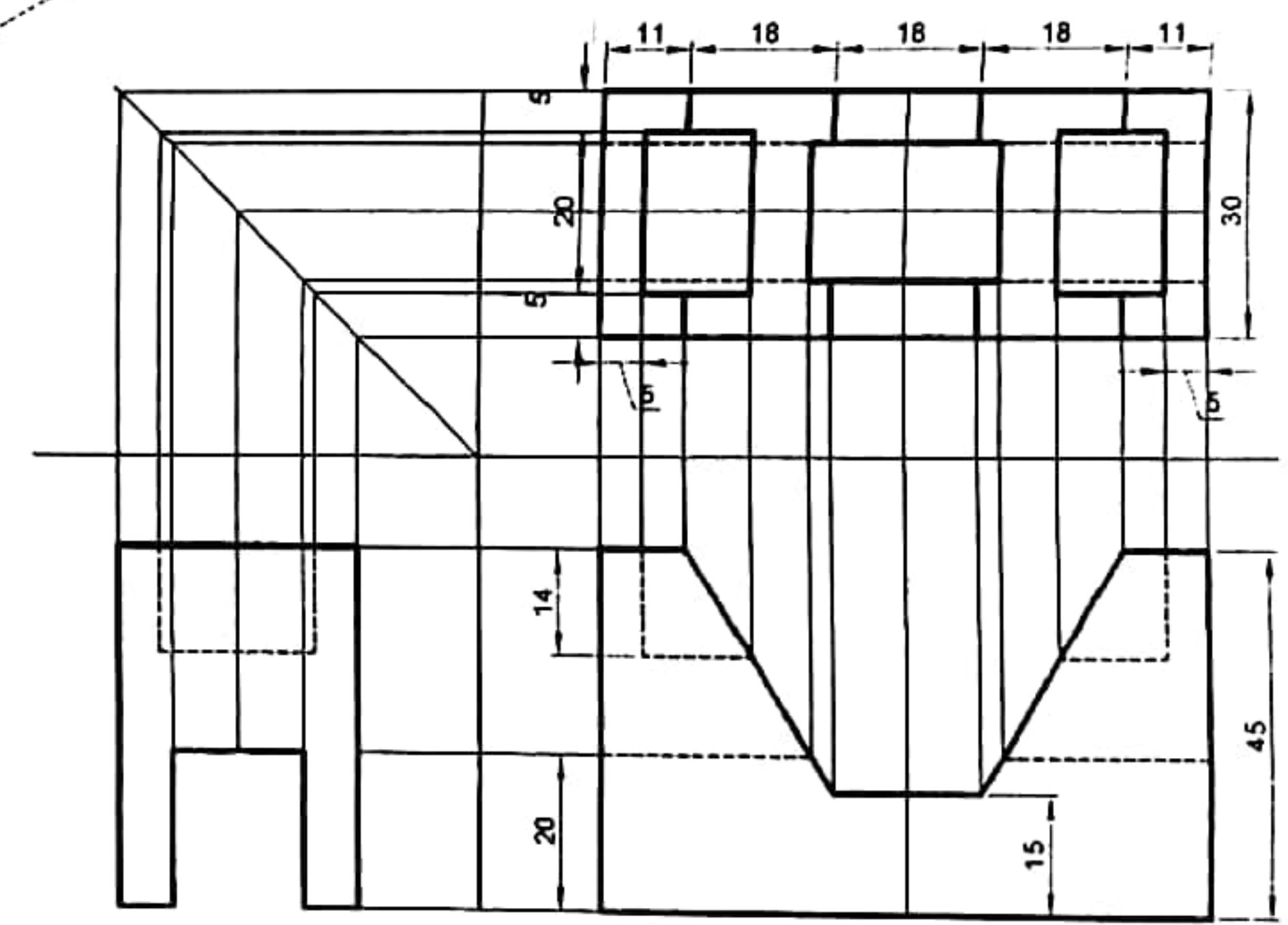
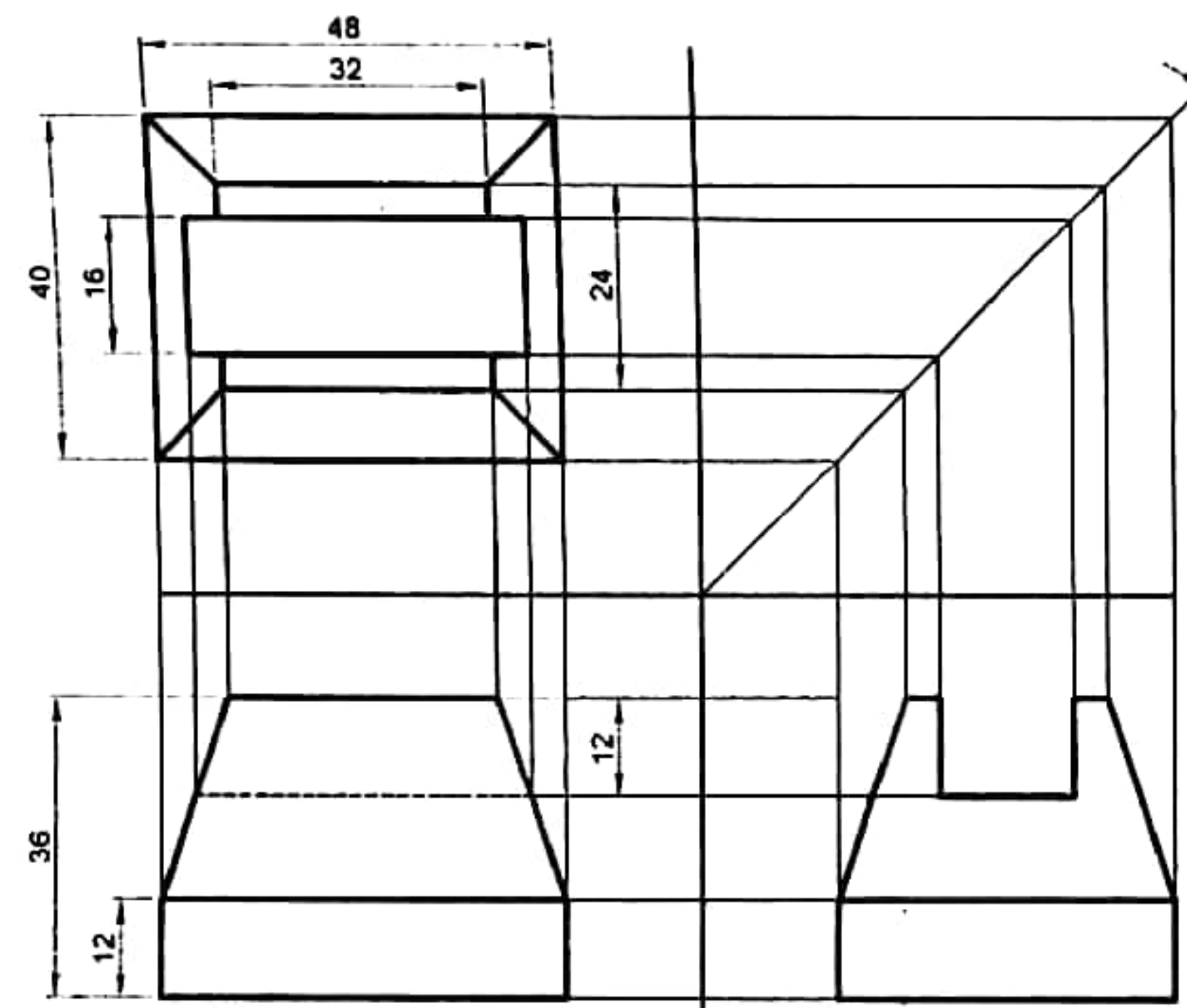

FRONT VIEW

RIGHT SIDE VIEW

LEFT SIDE VIEW

FRONT VIEW

	SUBJECT	TITLE	DRAWN BY	CHECKED BY	DATE	SCALE
	ENGINEERING DRAWING	ORTHOGRAPHIC PROJECTION OF SOLIDS (Third angle projection)	NAME ROLL NO			
				DATE	DRAWING NO OP-6	

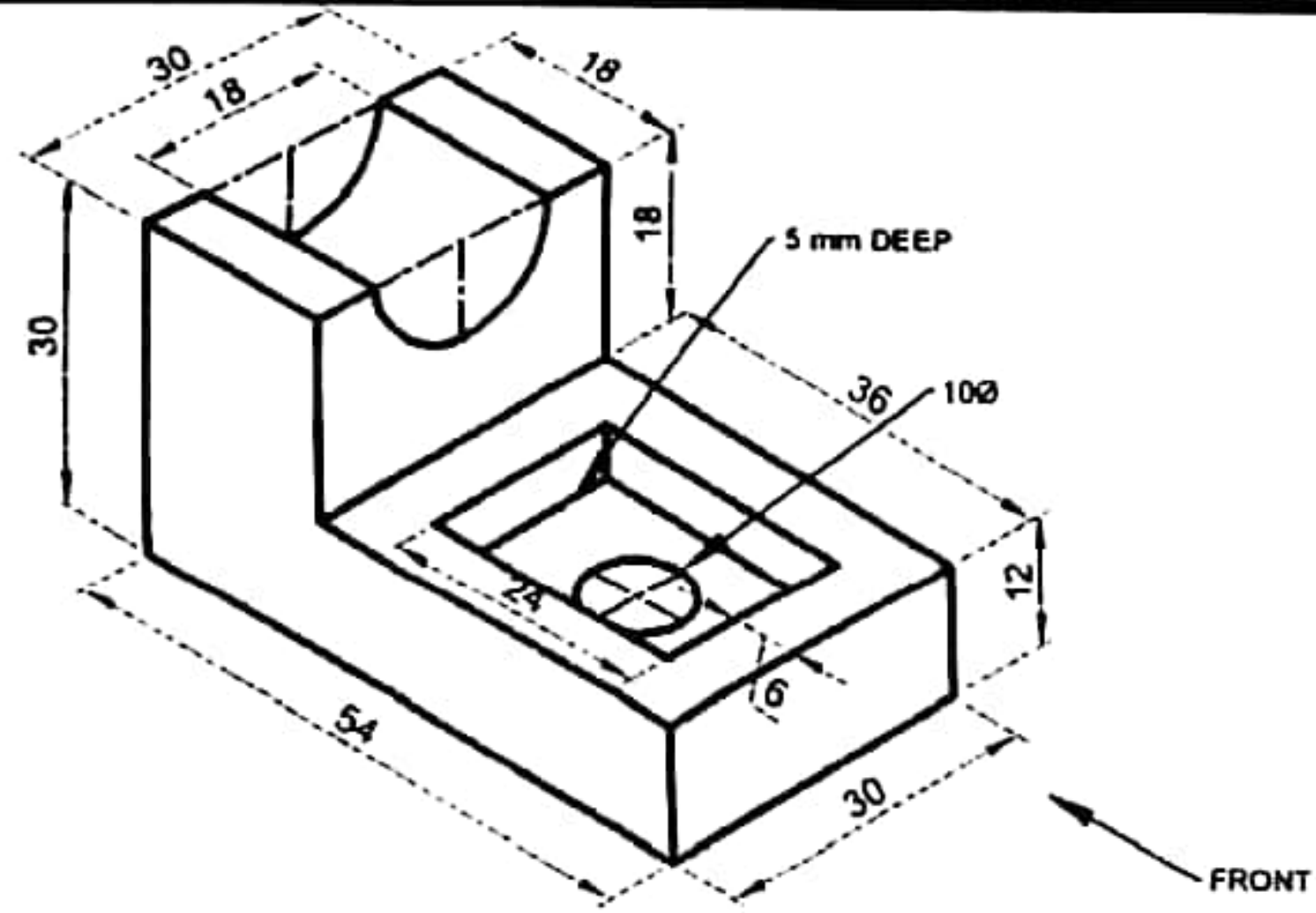

ISOMETRIC VIEW OF GIVEN SOLID

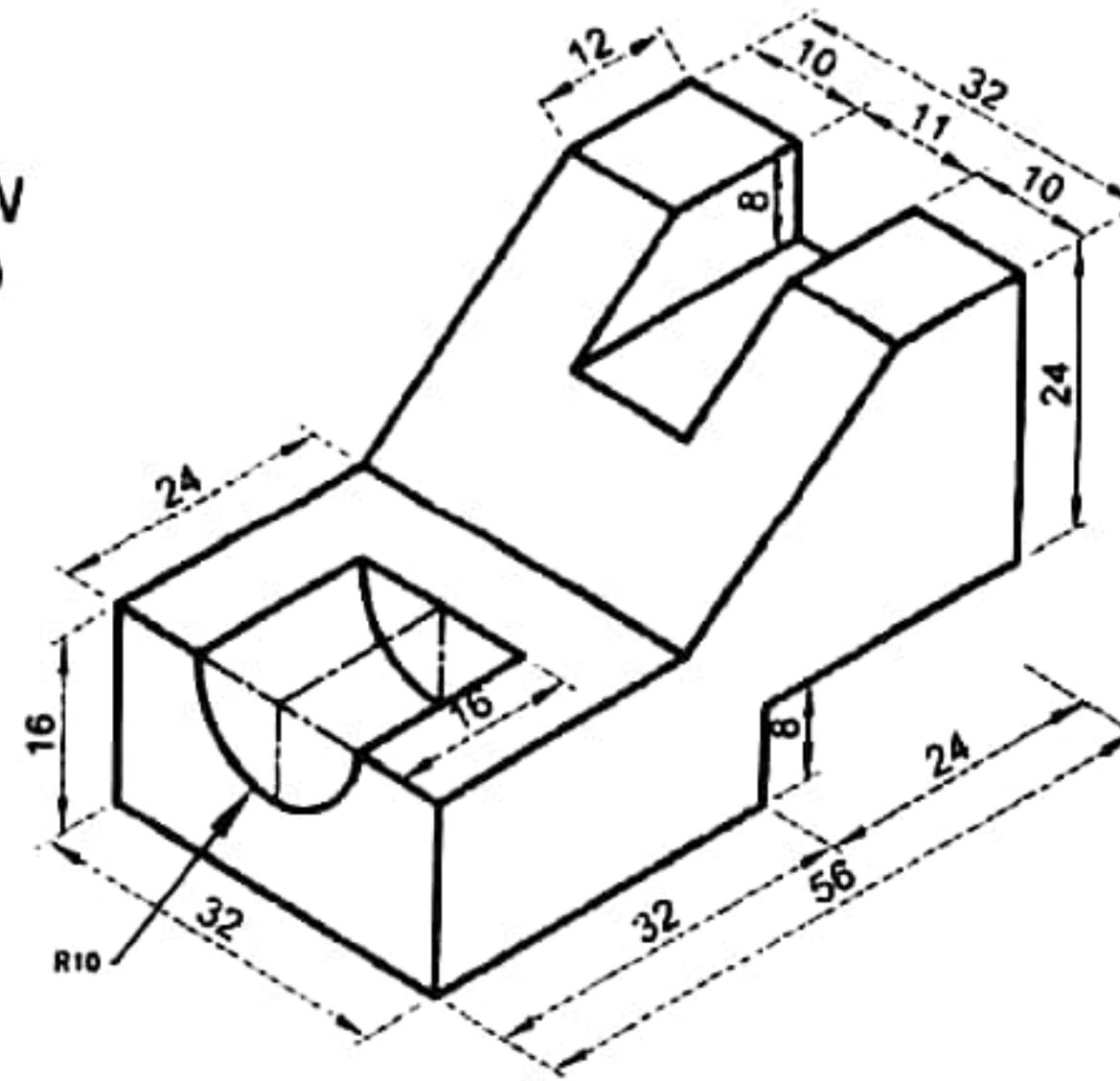

TOP VIEW

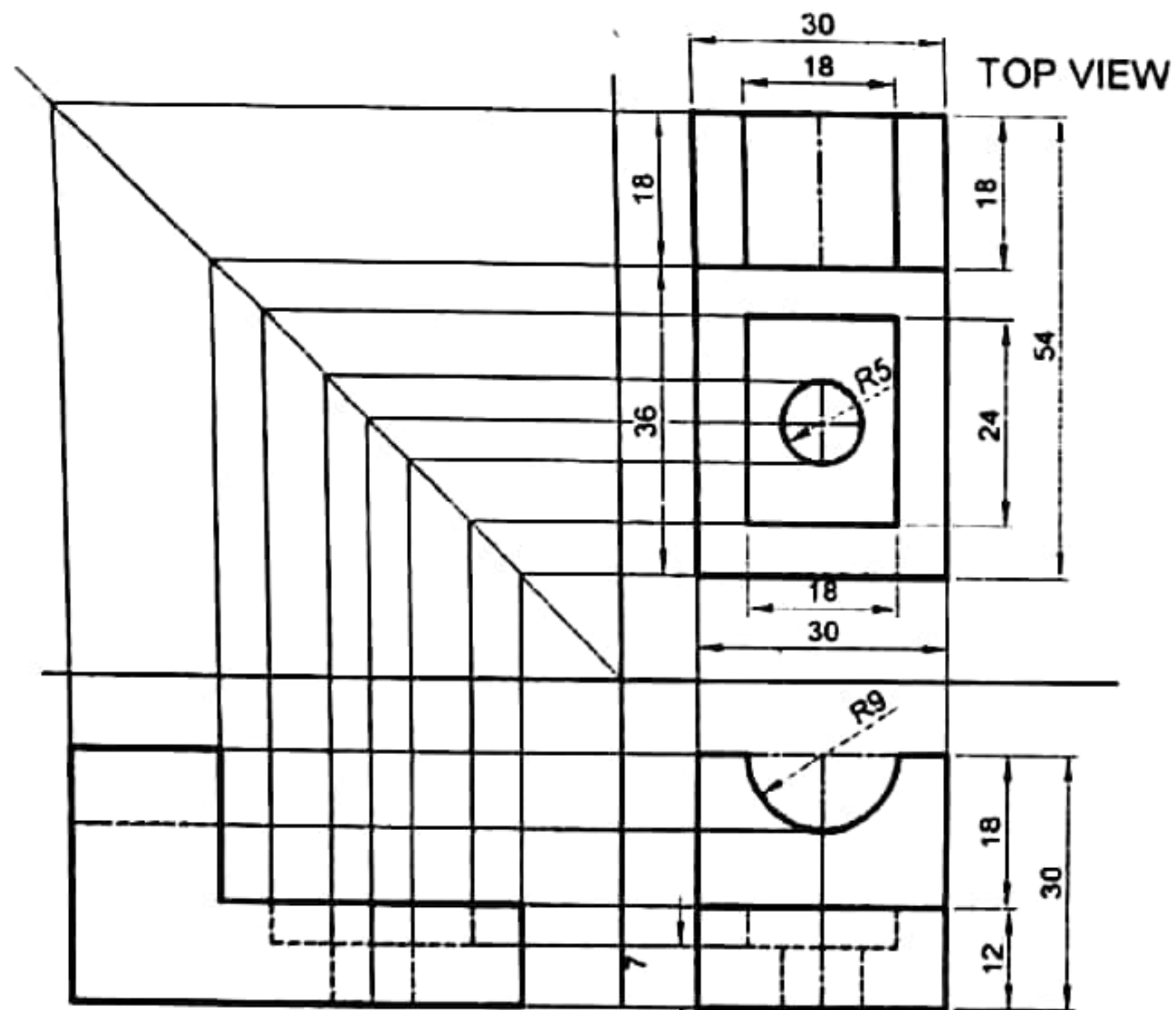

LEFT SIDE VIEW

FRONT VIEW

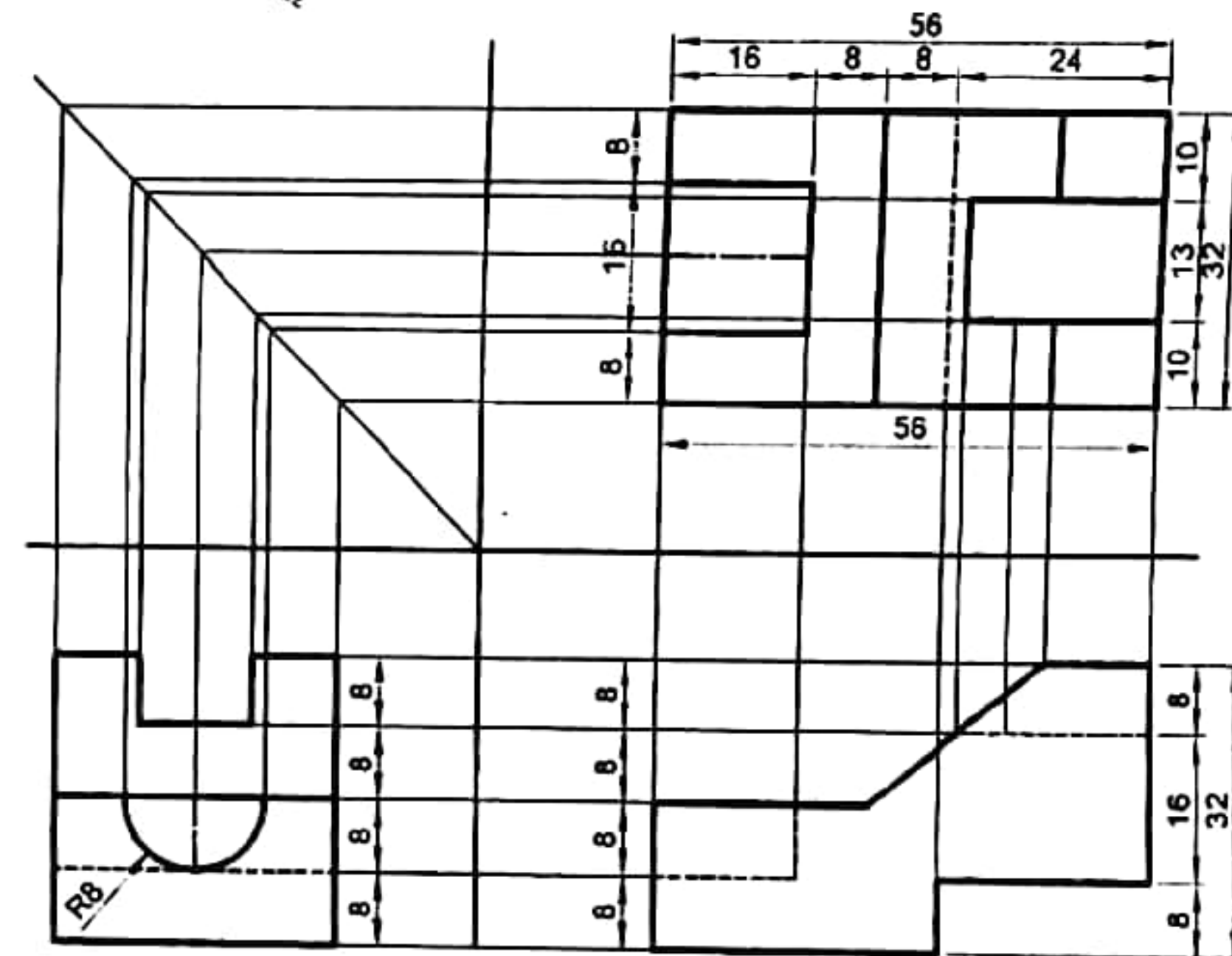

LEFT SIDE VIEW

FRONT VIEW

				50		45		45			
SUBJECT		TITLE		DRAWN BY		CHECKED BY		DATE		SCALE	
ENGINEERING DRAWING		ORTHOGRAPHIC PROJECTION PROJECTION OF SOLIDS (Third angle projection)		NAME ROLL NO							
				DATE		DRAWING NO				OP-7	

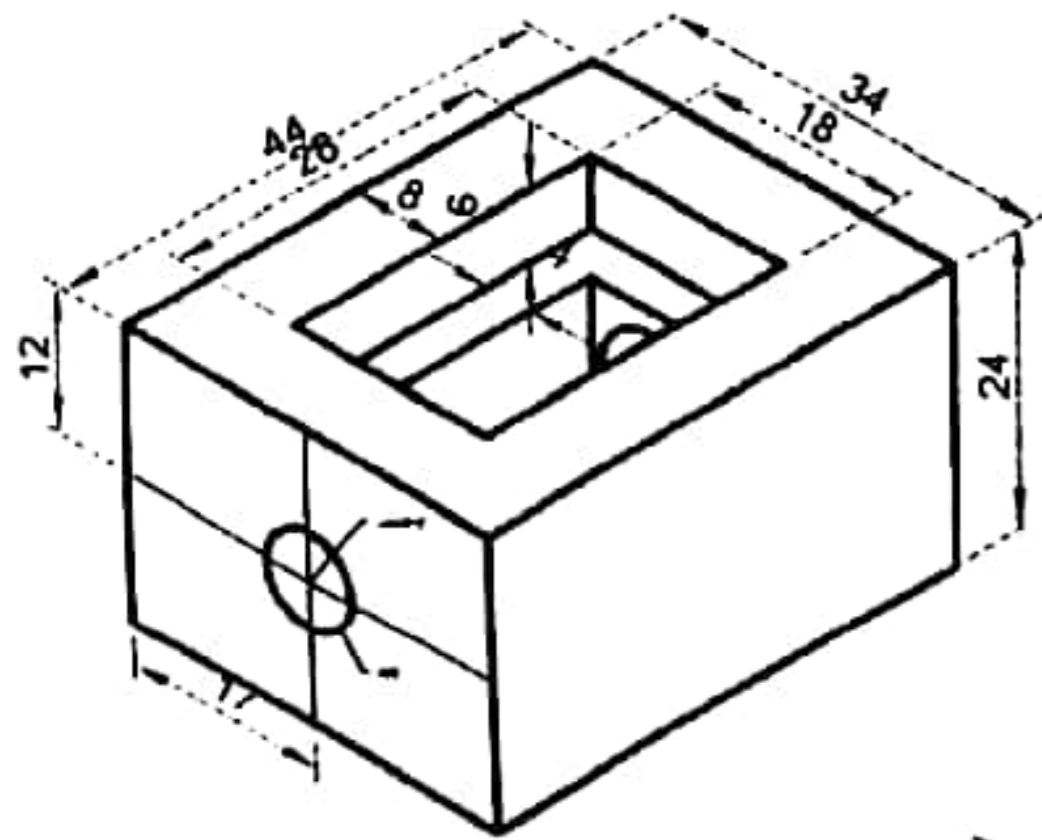

ISOMETRIC VIEW

Draw the orthographic projection of solids (three plane projection) in scale 2:1 with necessary dimension. (Third angle projection)

ISOMETRIC VIEW OF GIVEN SOLID

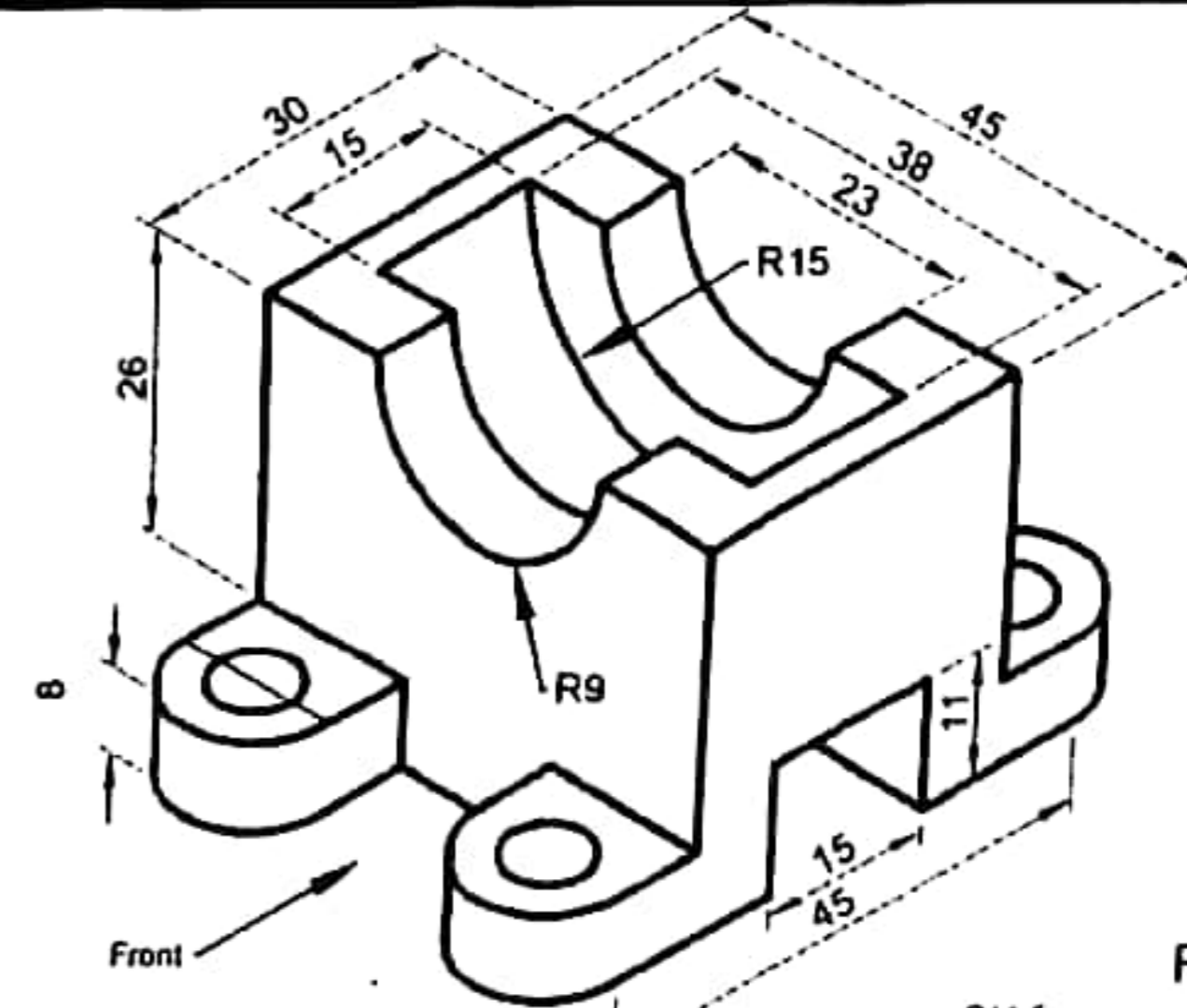

FRONT VIEW

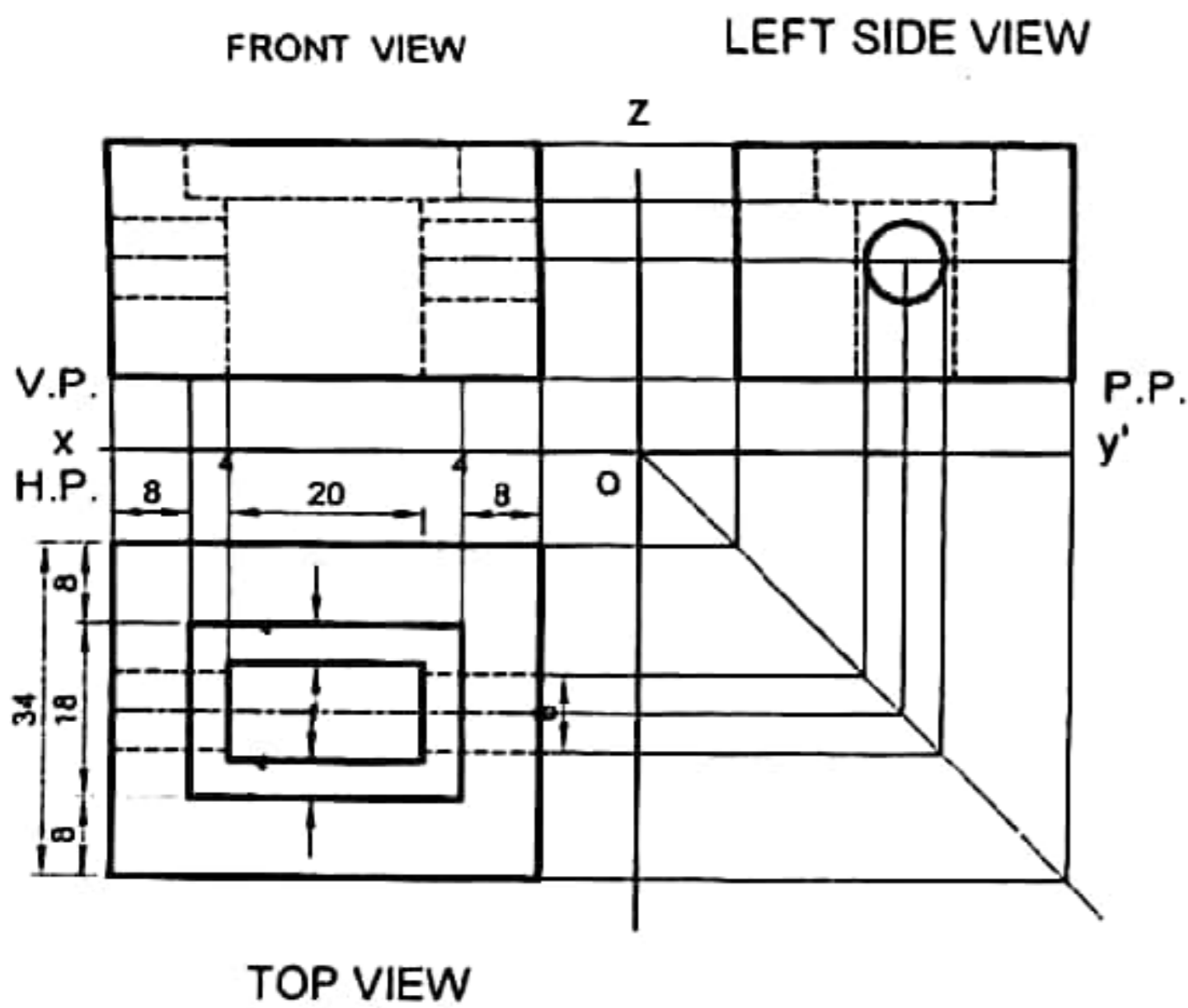

ORTHOGRAPHIC PROJECTION OF SOLIDS IN FIRST ANGLE PROJECTION

LEFT SIDE VIEW

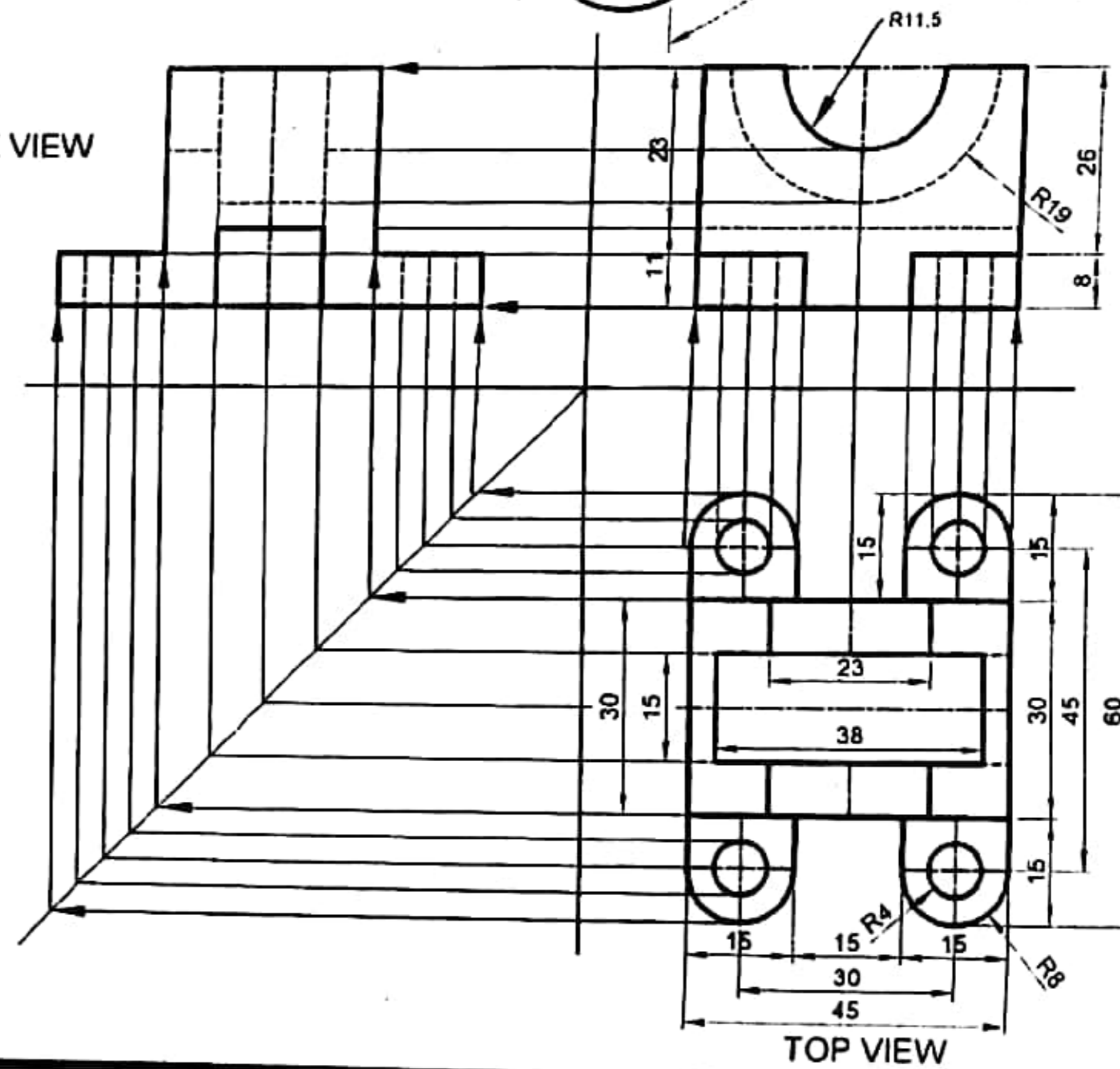

TOP VIEW

SUBJECT ENGINEERING DRAWING	TITLE ORTHOGRAPHIC PROJECTION OF SOLIDS (First angle projection)	DRAWN BY NAME ROLL NO	CHECKED BY	DATE	SCALE
				DATE	DRAWING NO OP-8

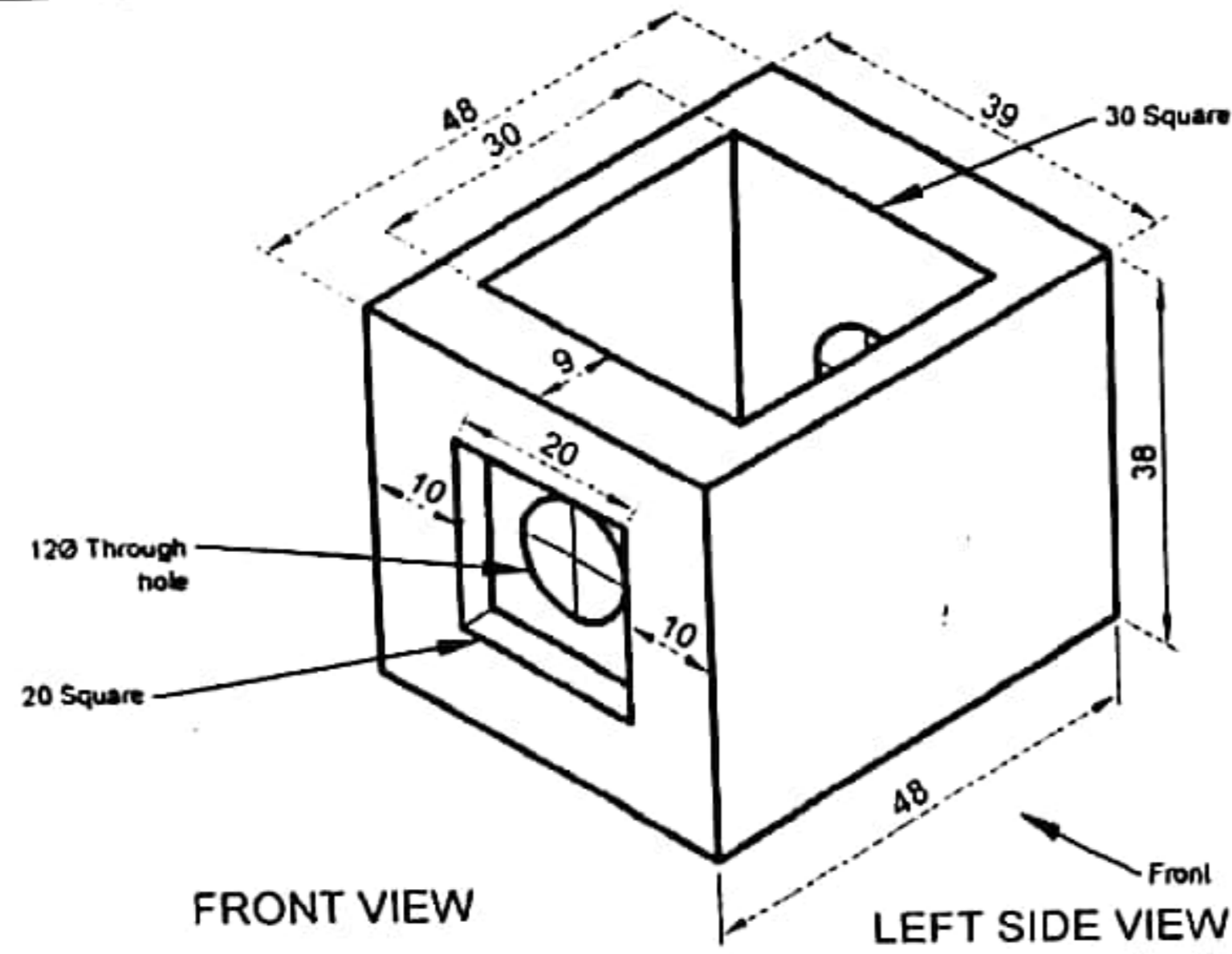

ISOMETRIC VIEW OF GIVEN SOLID

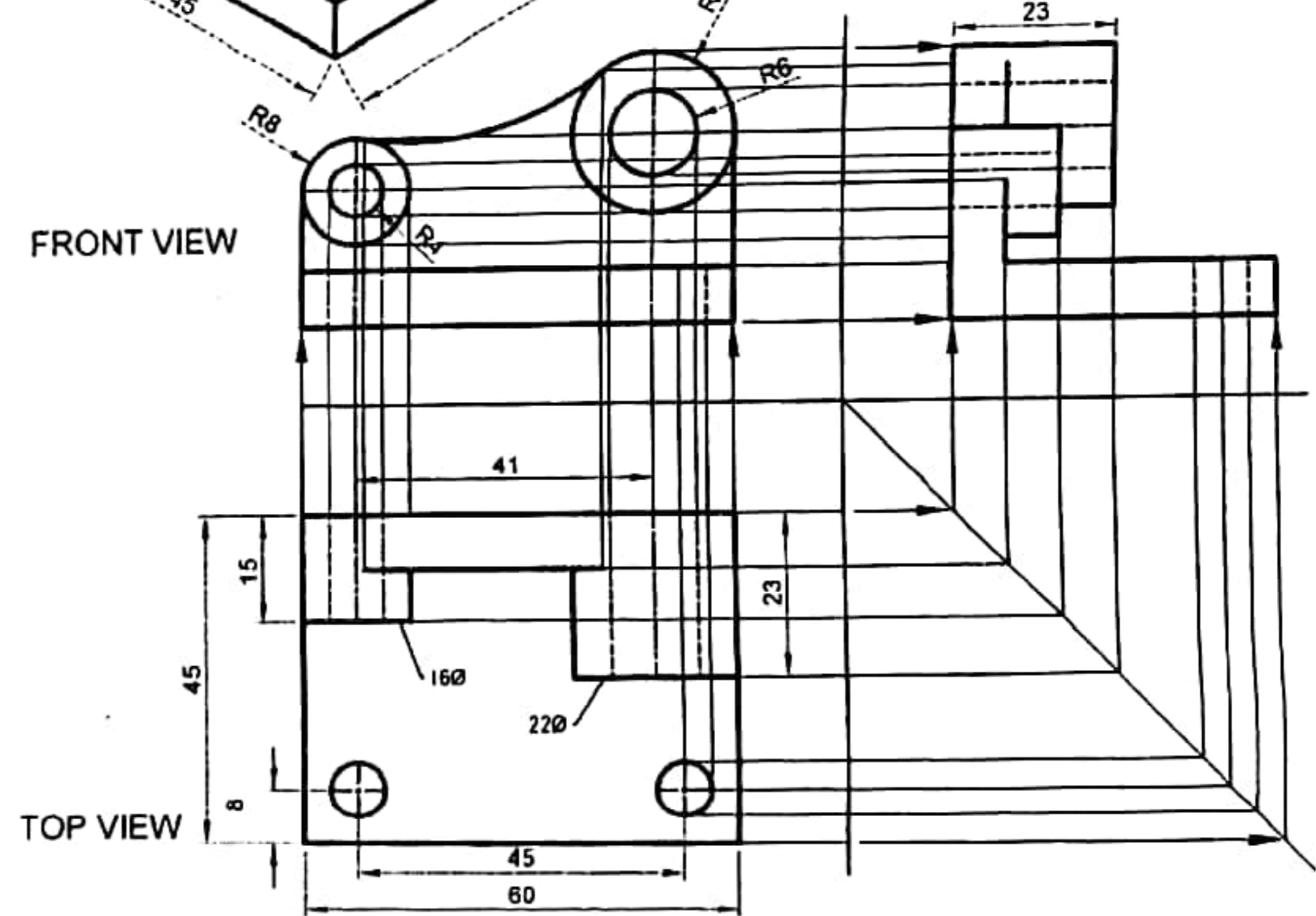
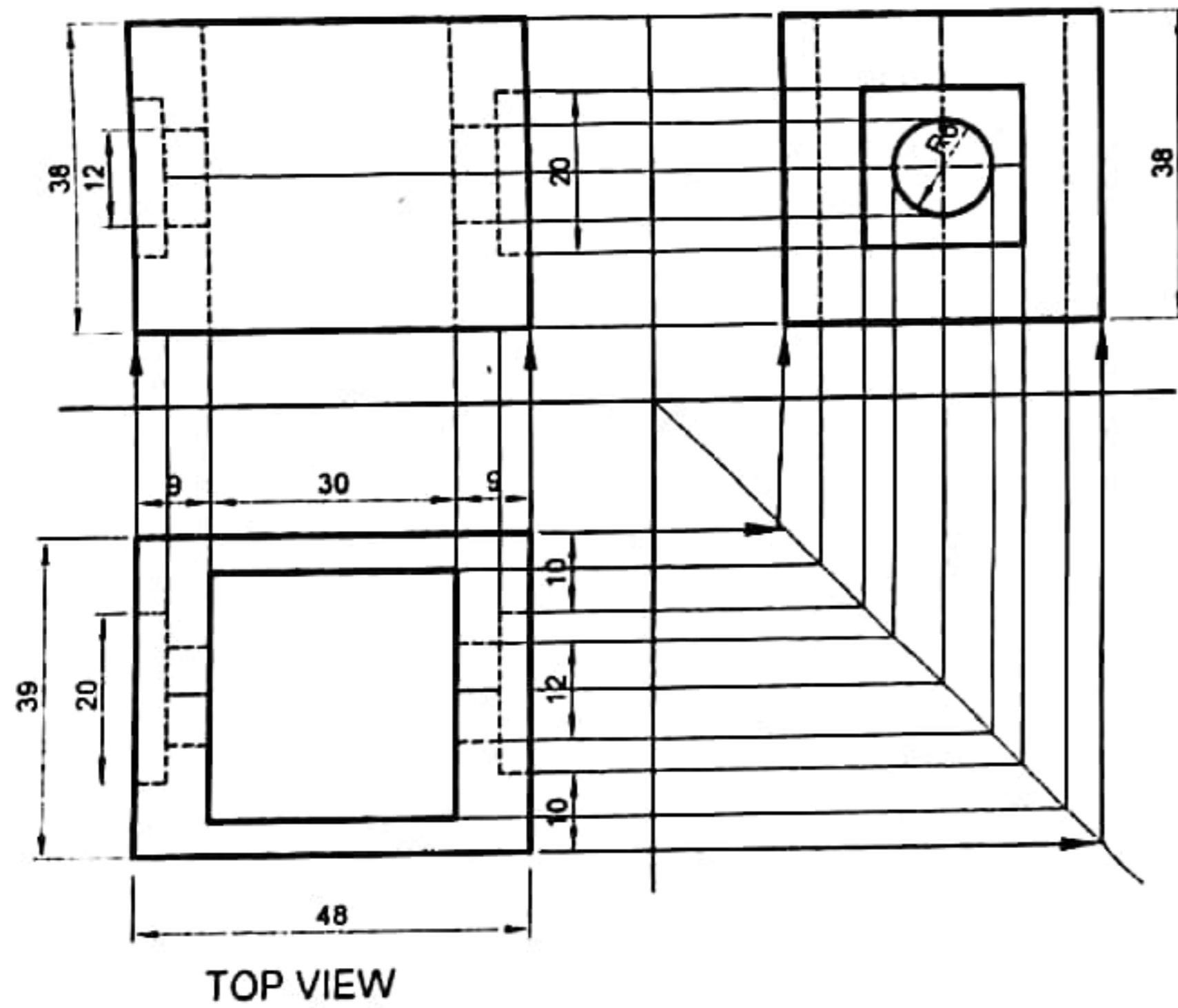
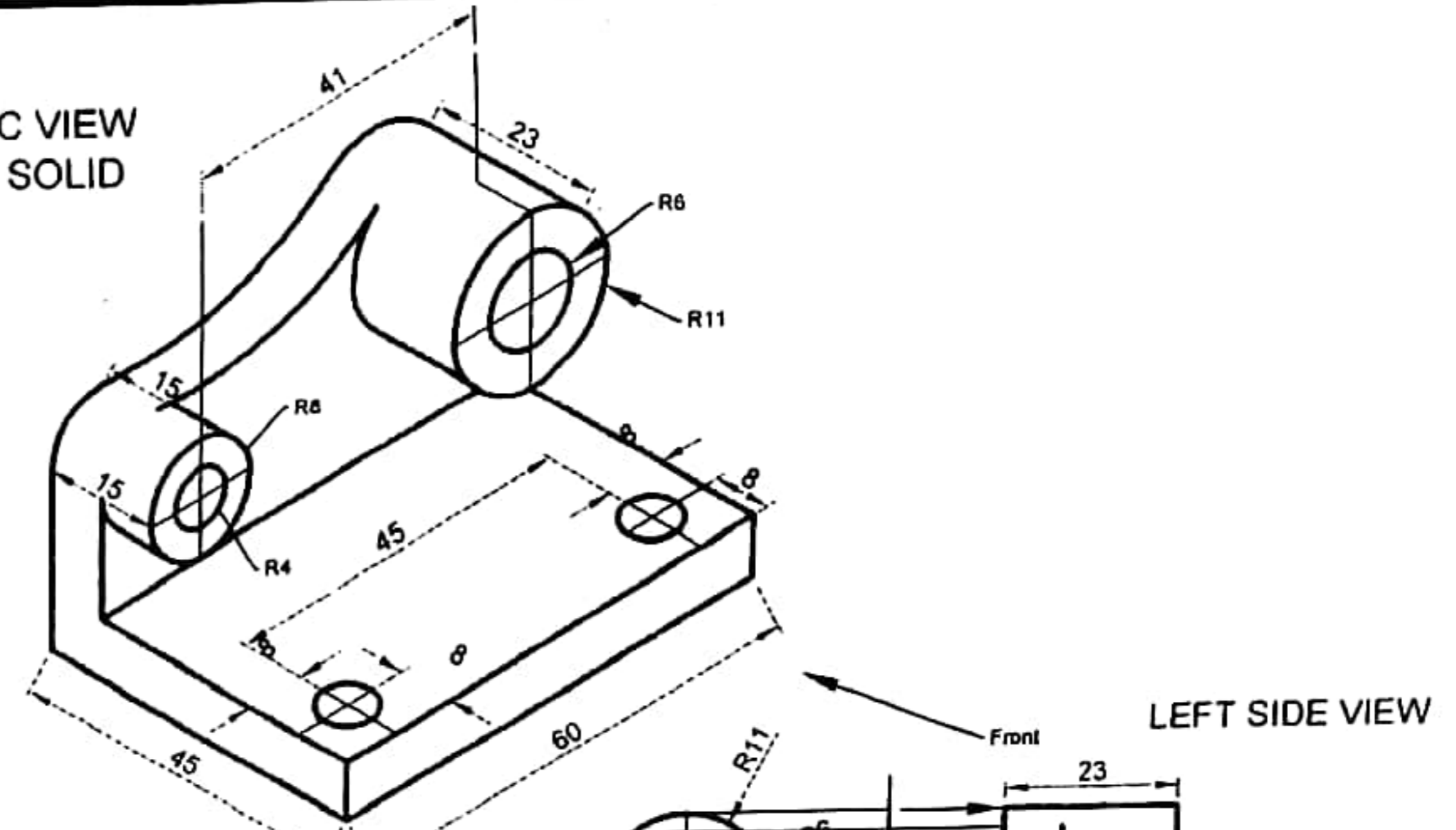

	SUBJECT	TITLE	DRAWN BY	CHECKED BY	DATE	SCALE
	ENGINEERING DRAWING	ORTHOGRAPHIC PROJECTION OF SOLIDS (First angle projection)	NAME ROLL NO			
				DATE	DRAWING NO	OP-9

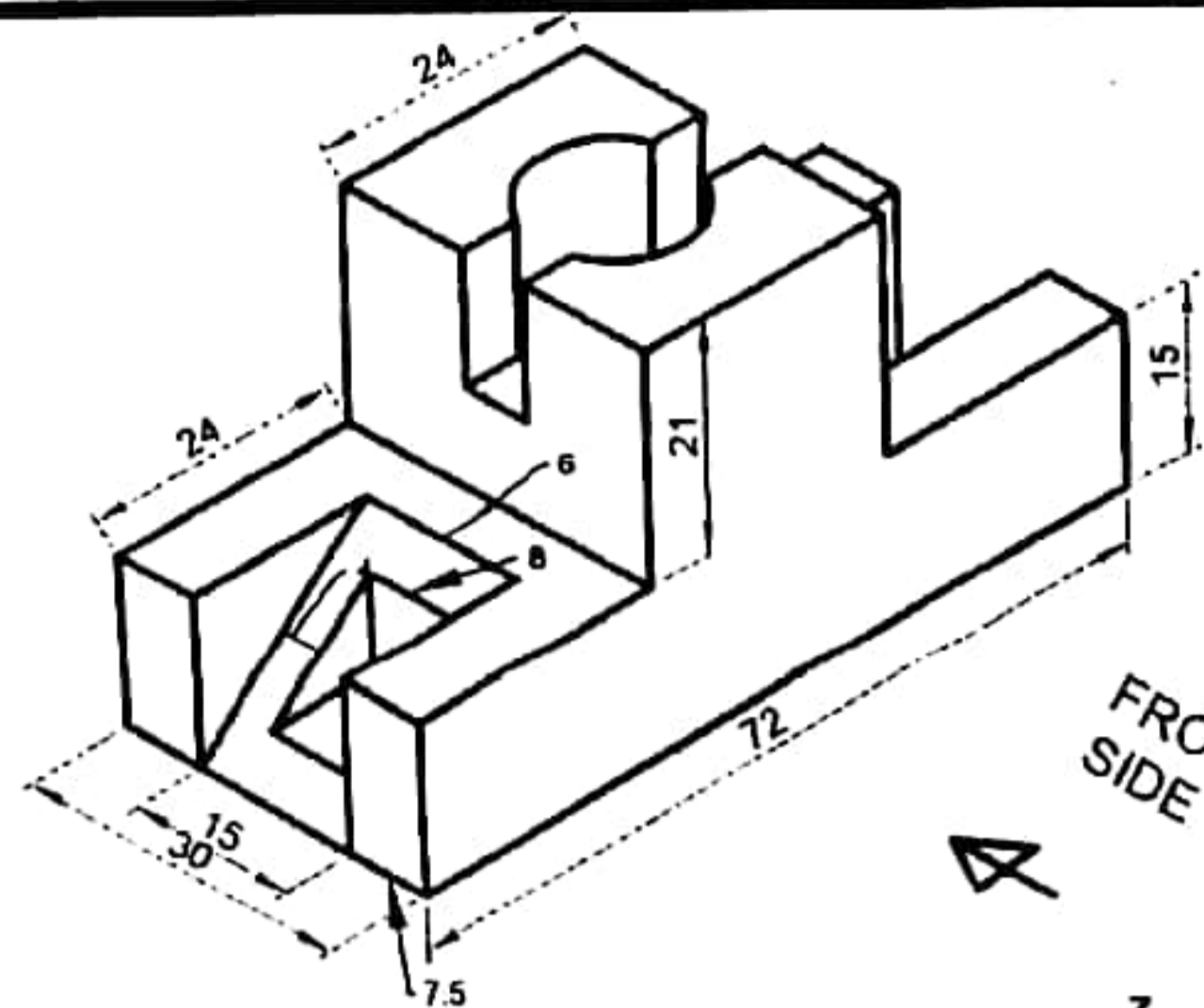

ISOMETRIC VIEW OF GIVEN SOLID

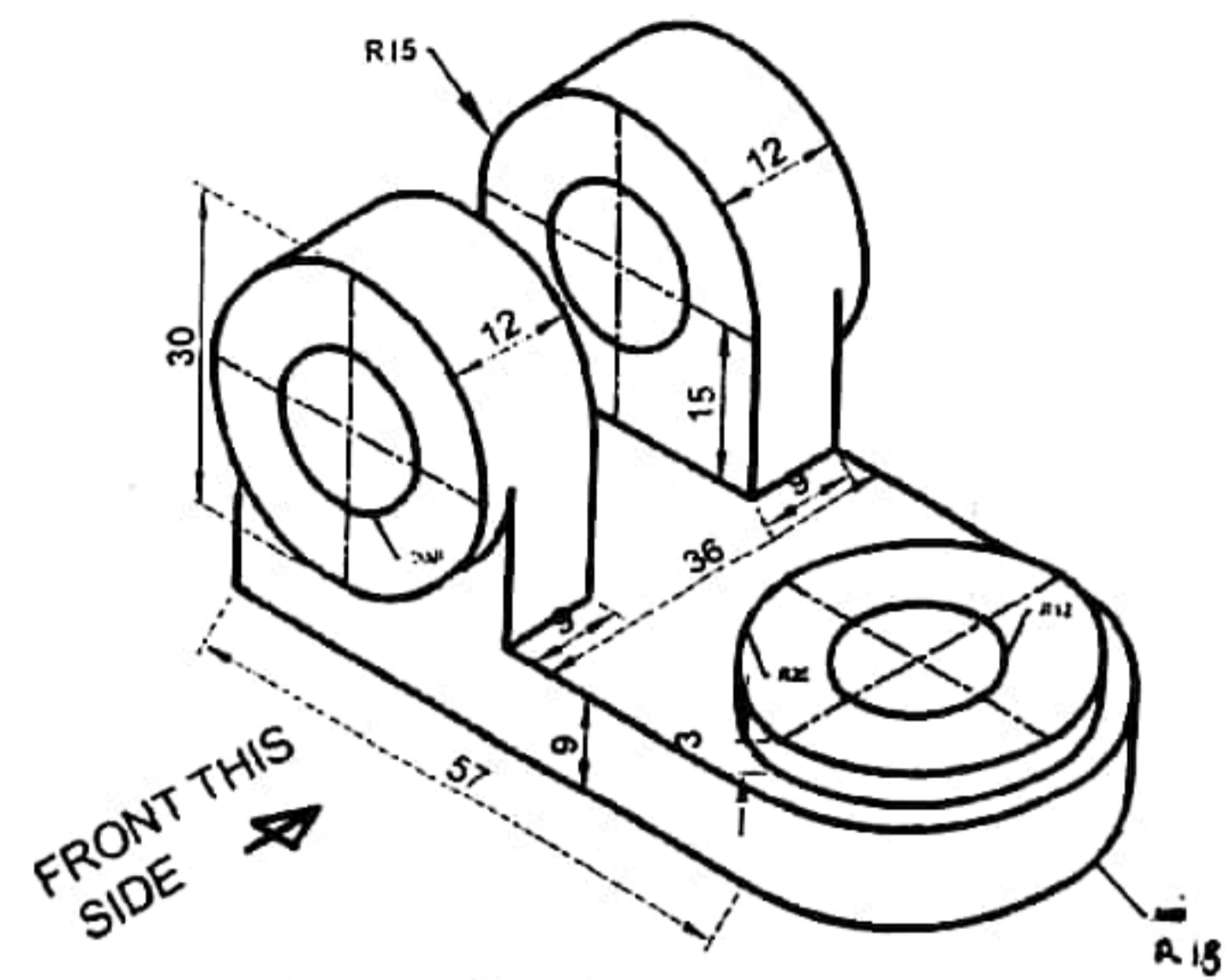

RIGHT SIDE VIEW

FRONT VIEW Z LEFT SIDE VIEW

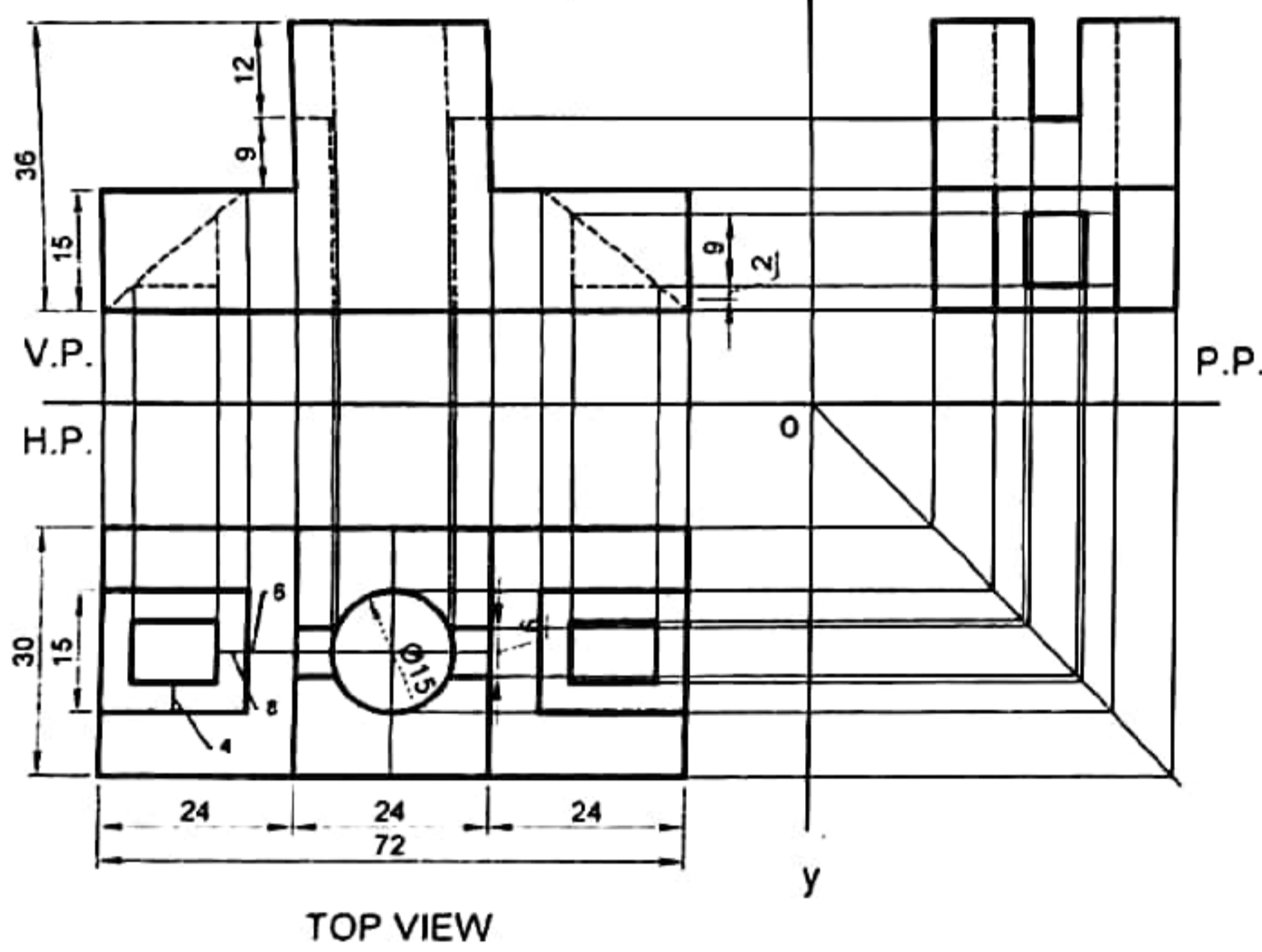

TOP VIEW

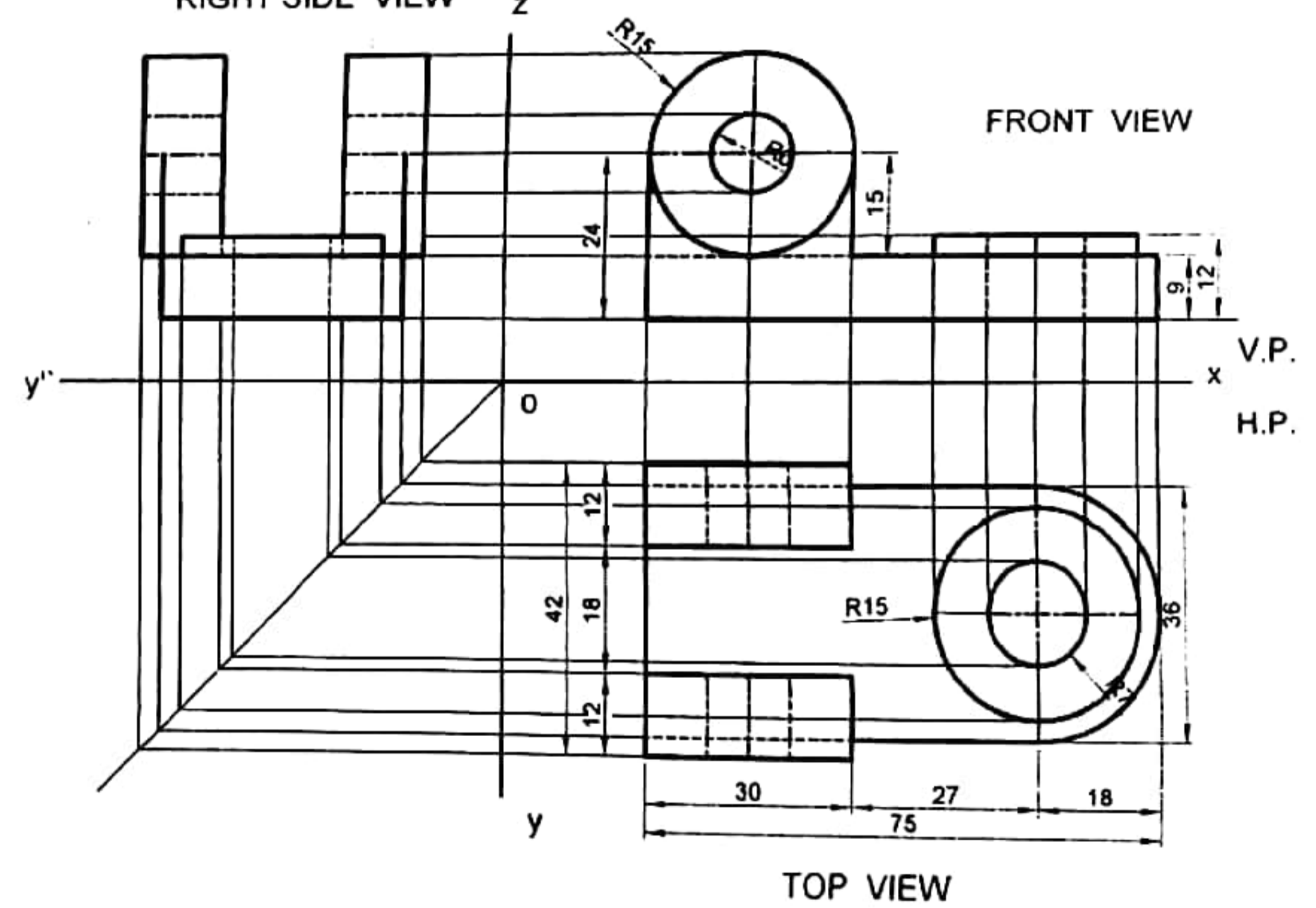

TOP VIEW

SUBJECT ENGINEERING DRAWING	TITLE ORTHOGRAPHIC PROJECTION PROJECTION OF SOLIDS (First angle projection)	DRAWN BY NAME ROLL NO	CHECKED BY DATE	DATE	SCALE
				DRAWING NO	

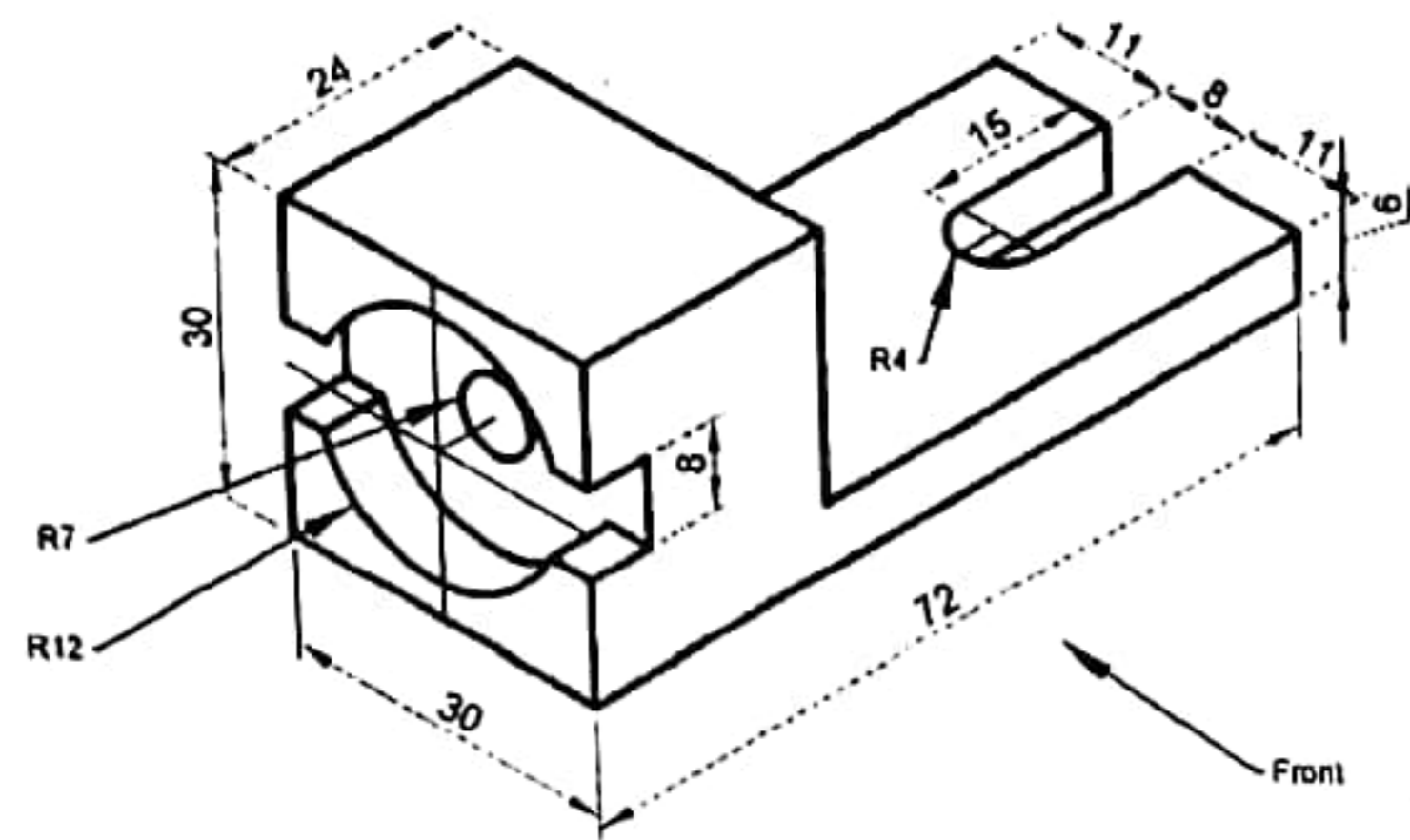

ISOMETRIC VIEW OF GIVEN SOLID

ISOMETRIC VIEW OF GIVEN SOLID

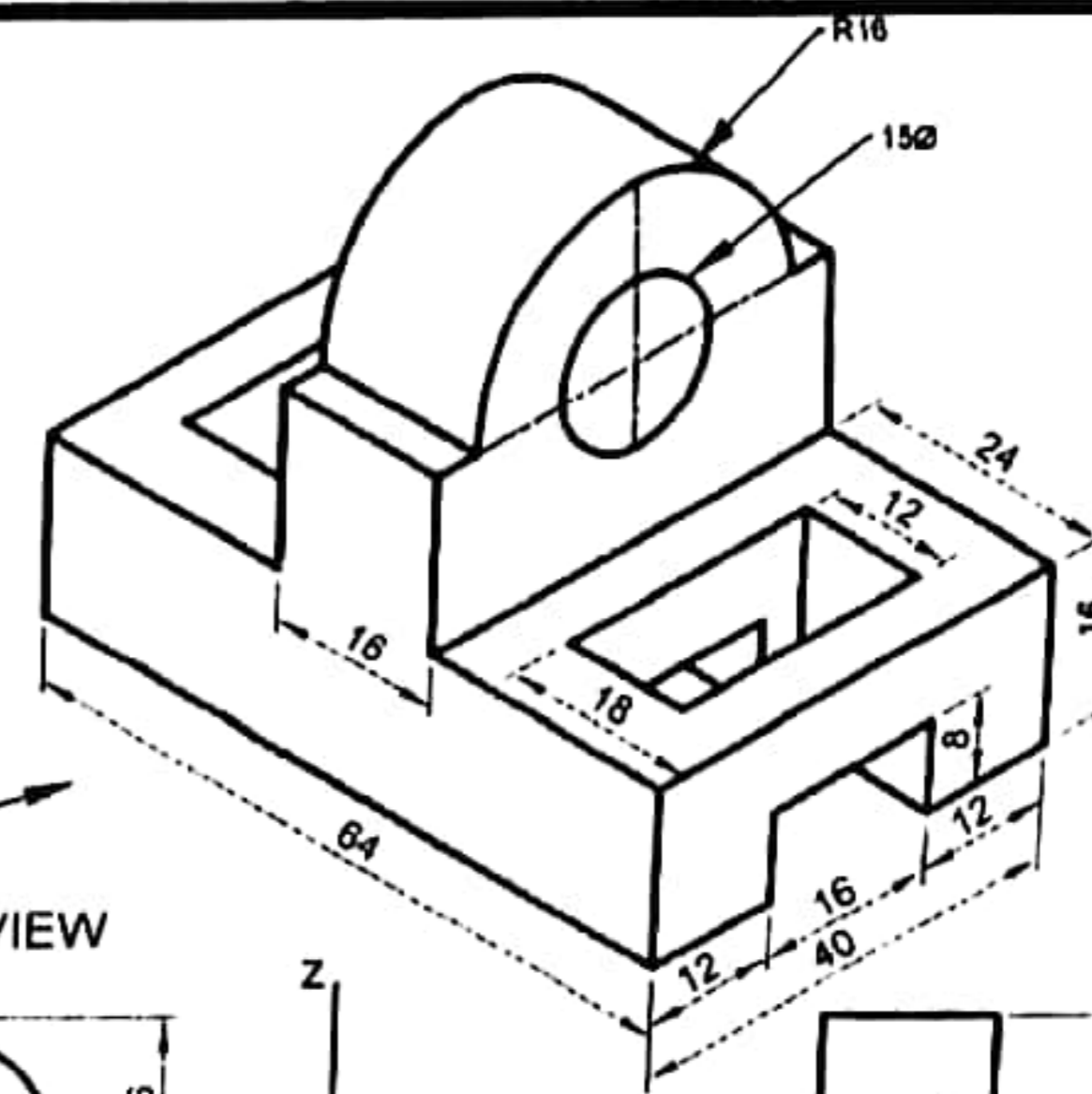

FRONT VIEW

LEFT SIDE VIEW

RIGHT SIDE VIEW

FRONT VIEW

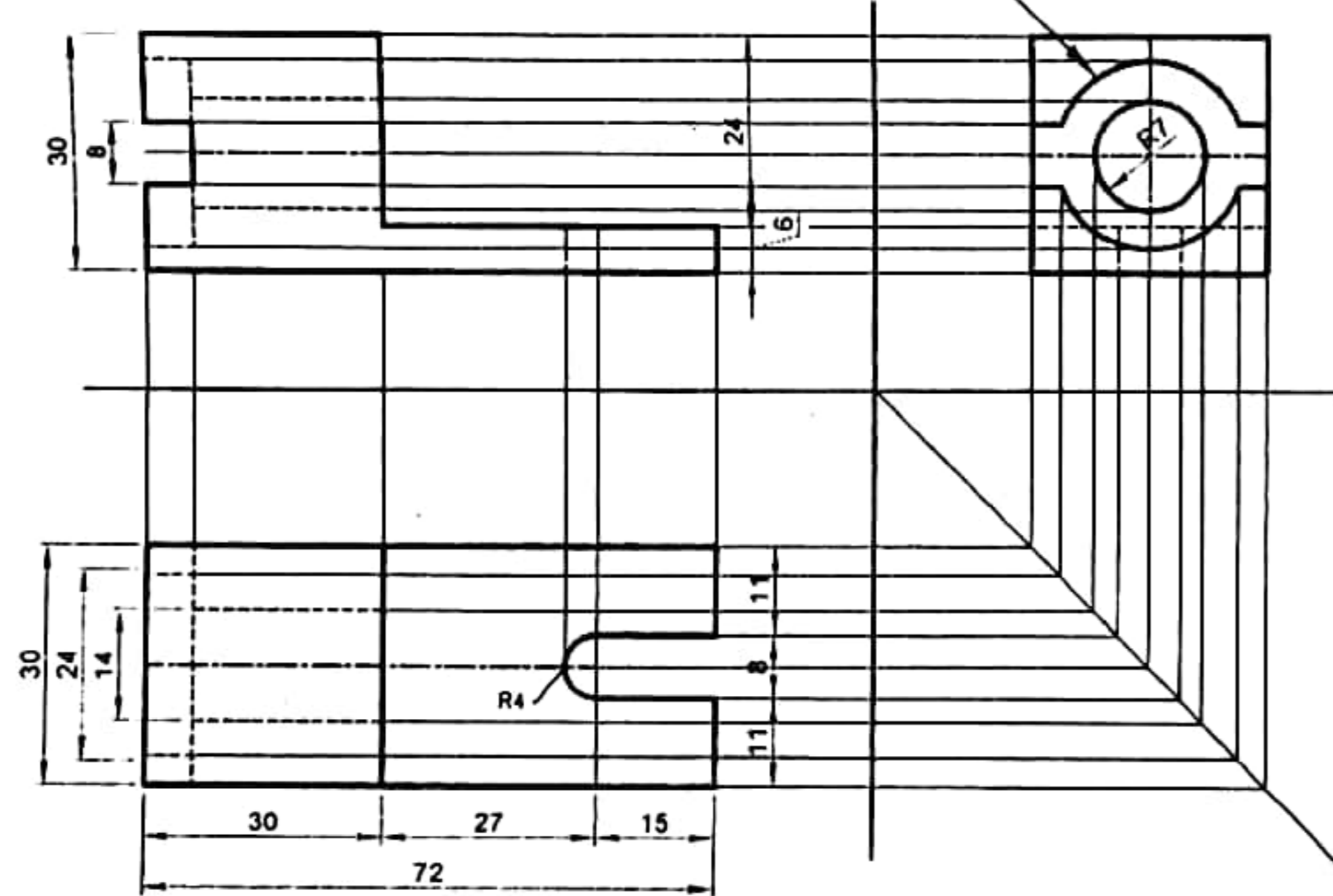

TOP VIEW

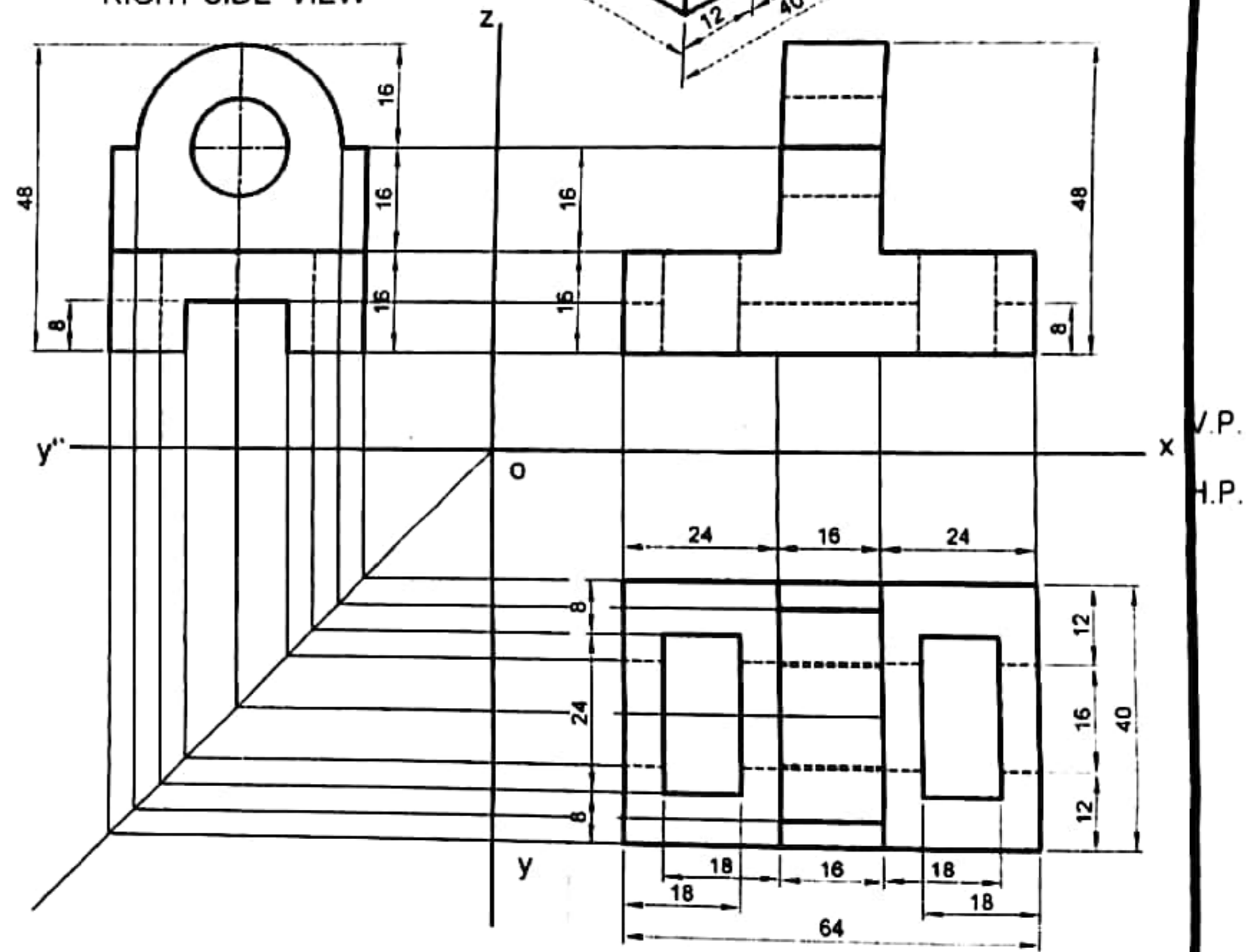

TOP VIEW

30	SUBJECT	TITLE	DRAWN BY	CHECKED BY	DATE	SCALE
	ENGINEERING DRAWING	ORTHOGRAPHIC PROJECTION OF SOLIDS (First angle projection)	NAME ROLL NO			
				DATE	DRAWING NO	OP-11

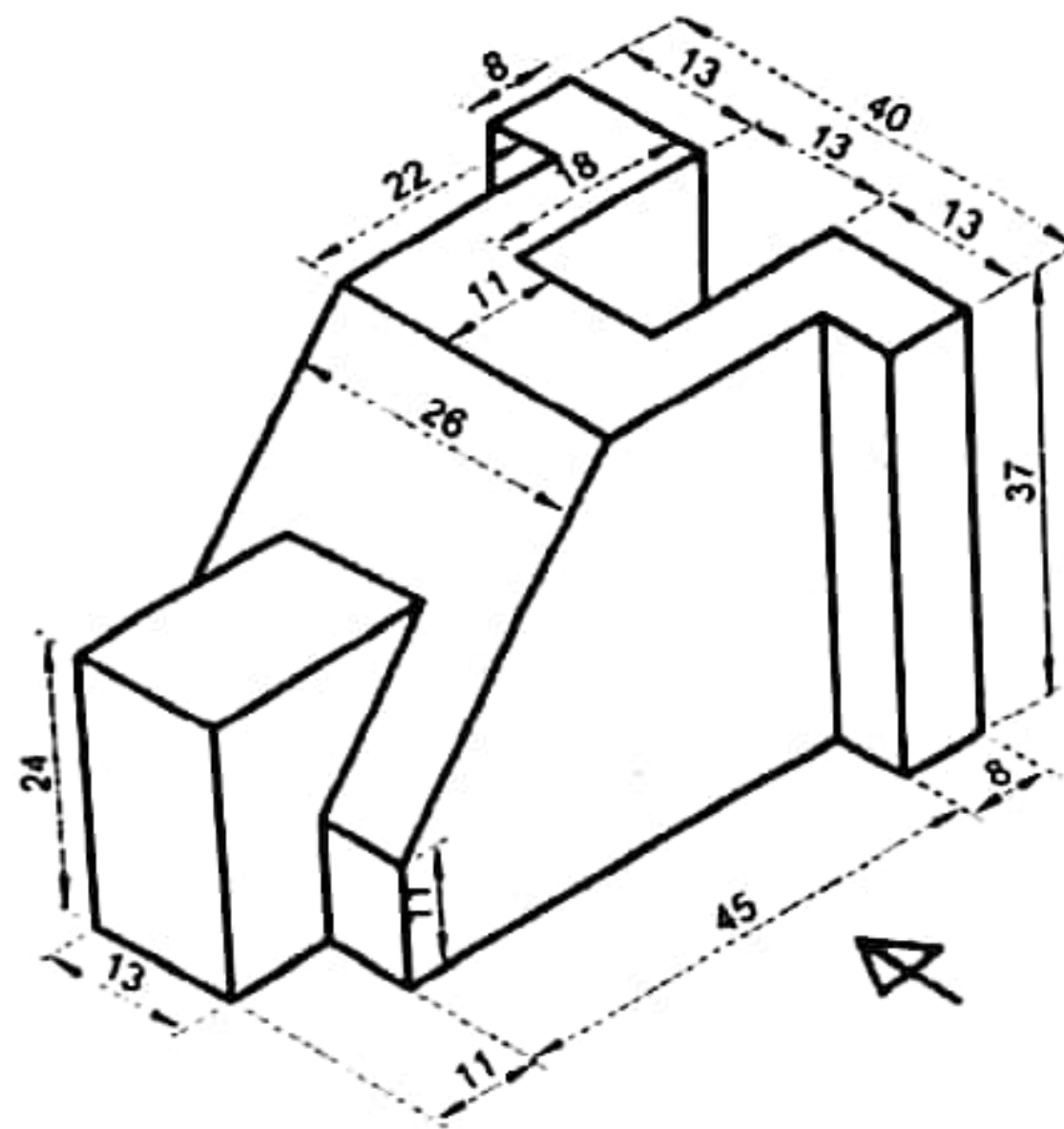

Draw the orthographic projection of solid (three plane projection) in scale 2:1 with necessary dimension. (Third angle projection) According to given arrow direction as front view.

ISOMETRIC VIEW OF GIVEN SOLIDS

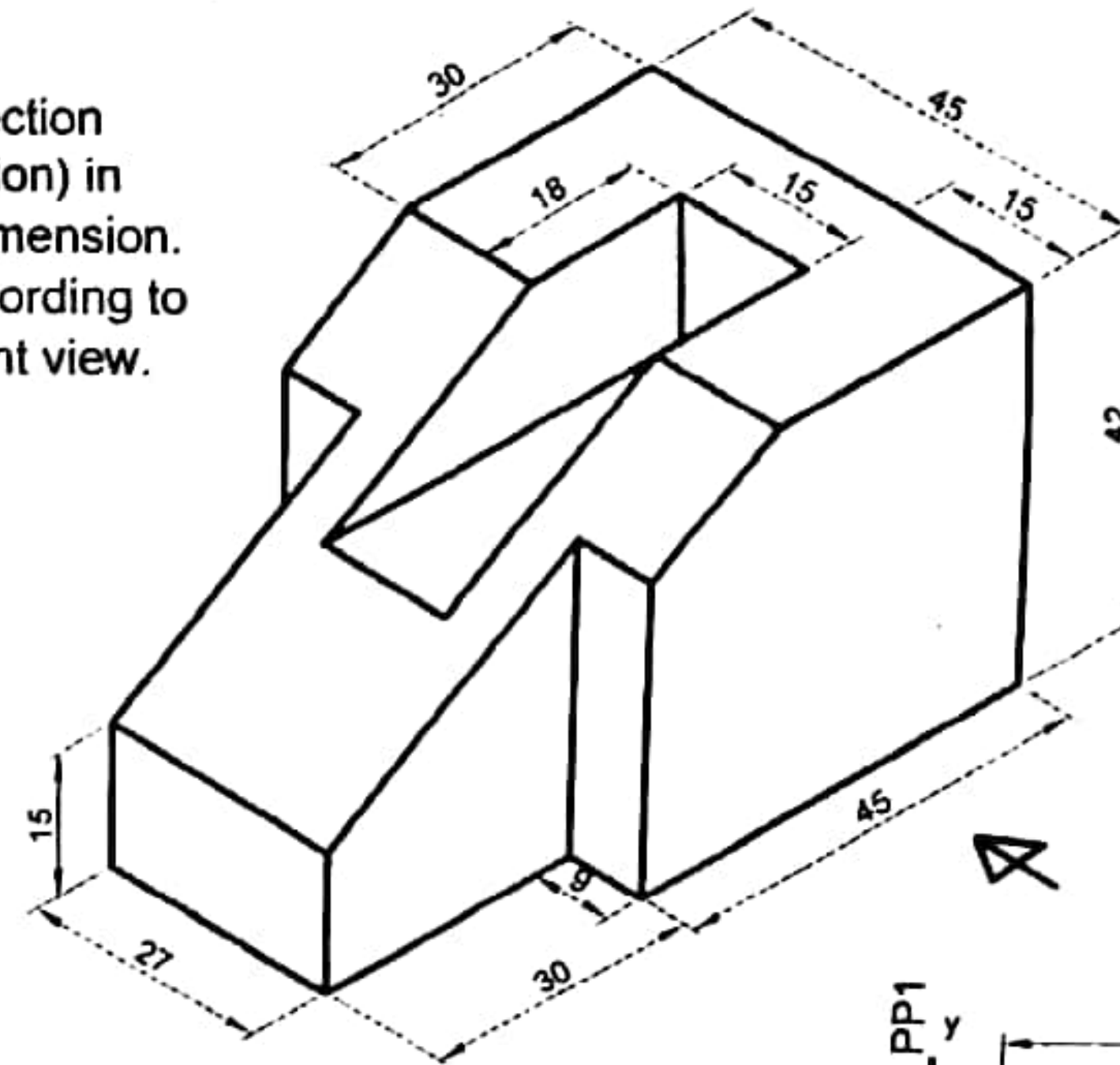

ISOMETRIC VIEW

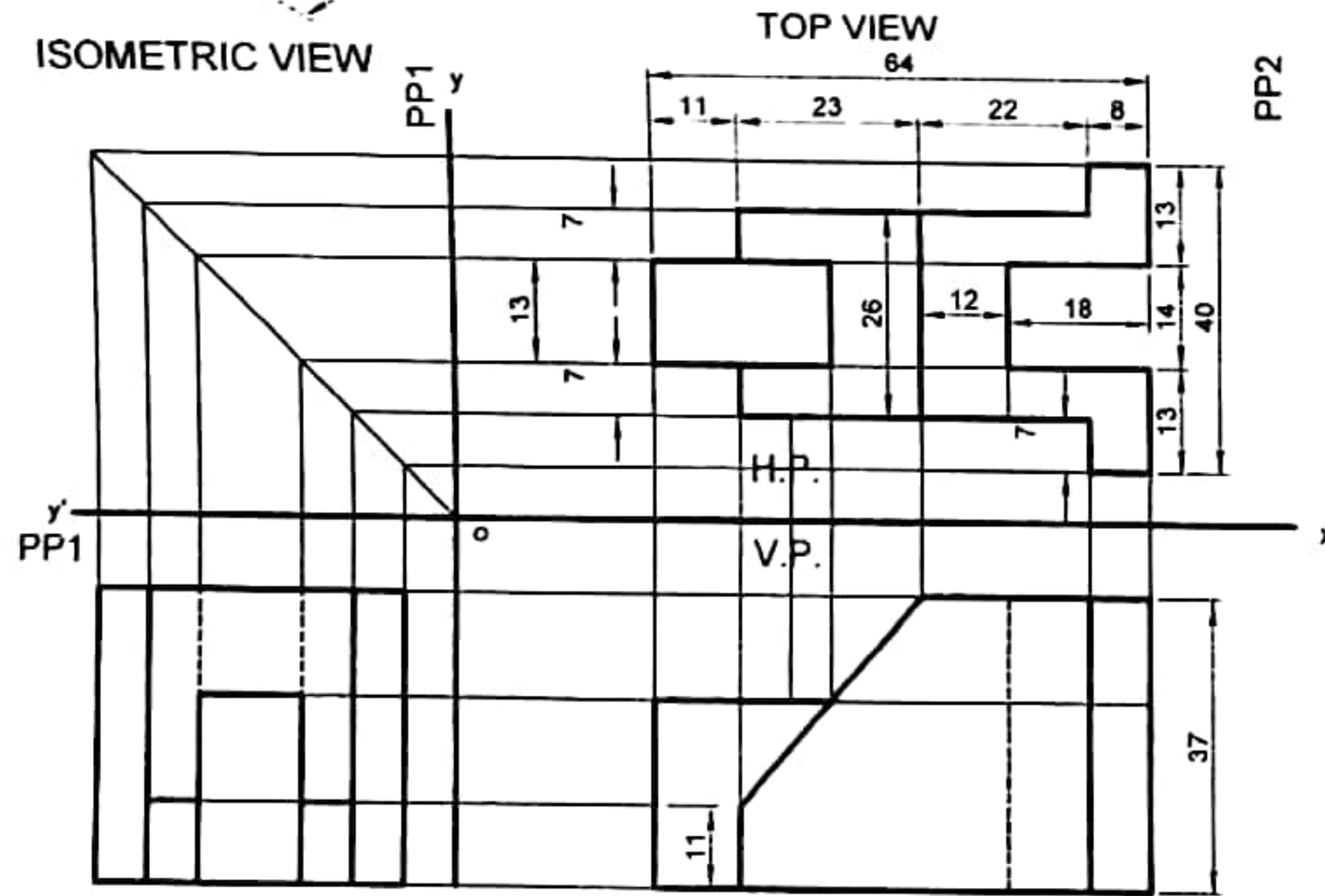

LEFT SIDE VIEW

FRONT VIEW

ORTHOGRAPHIC PROJECTION OF SOLIDS IN THIRD ANGLE PROJECTION

LEFT SIDE VIEW

FRONT VIEW

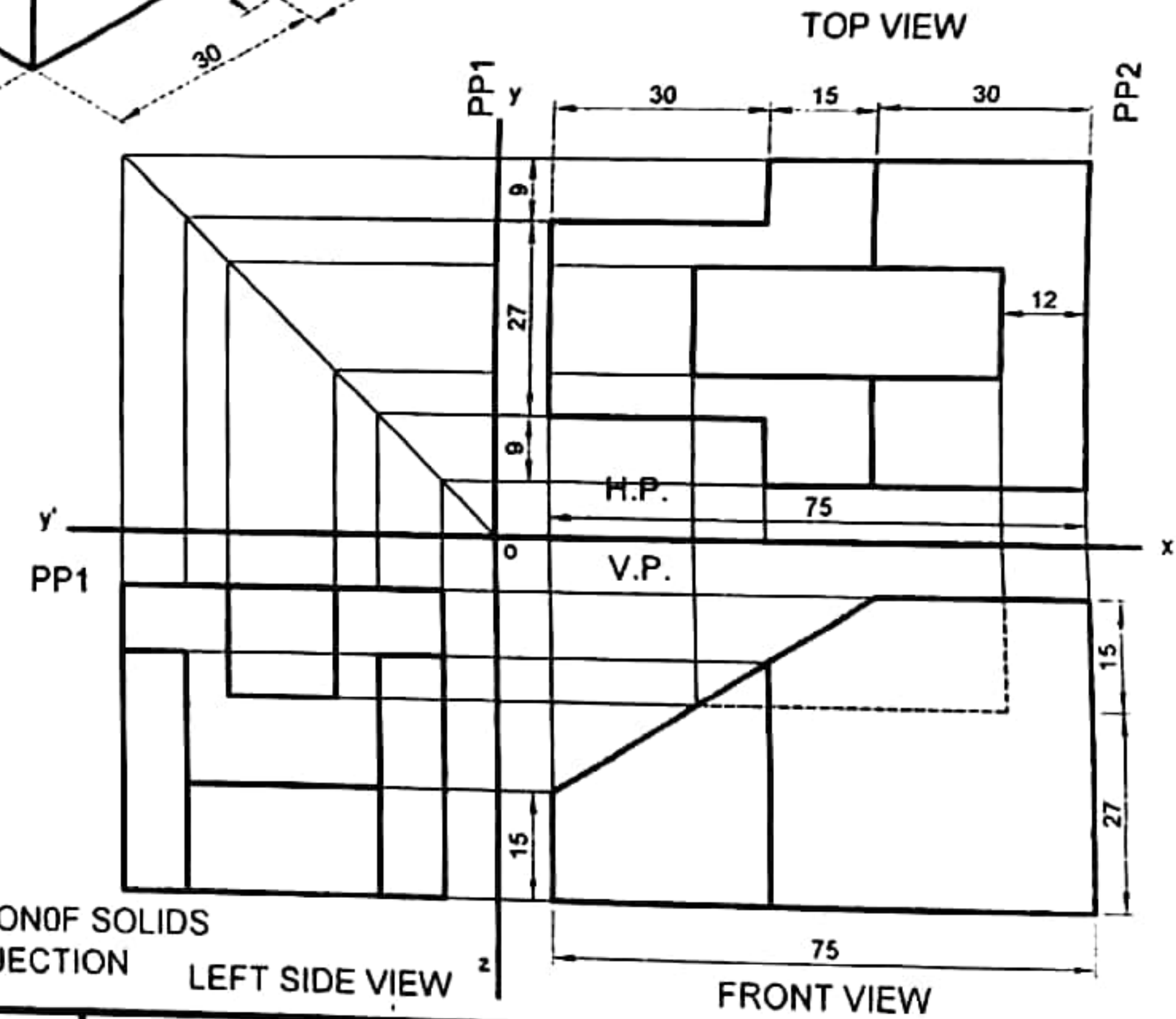

SUBJECT ENGINEERING DRAWING	TITLE ORTHOGRAPHIC PROJECTION PROJECTION OF SOLIDS (THIRD ANGLE PROJECTION)	DRAWN BY NAME ROLL NO	CHECKED BY	DATE	SCALE
				DATE	DRAWING NO OP-12

ISOMETRIC VIEW

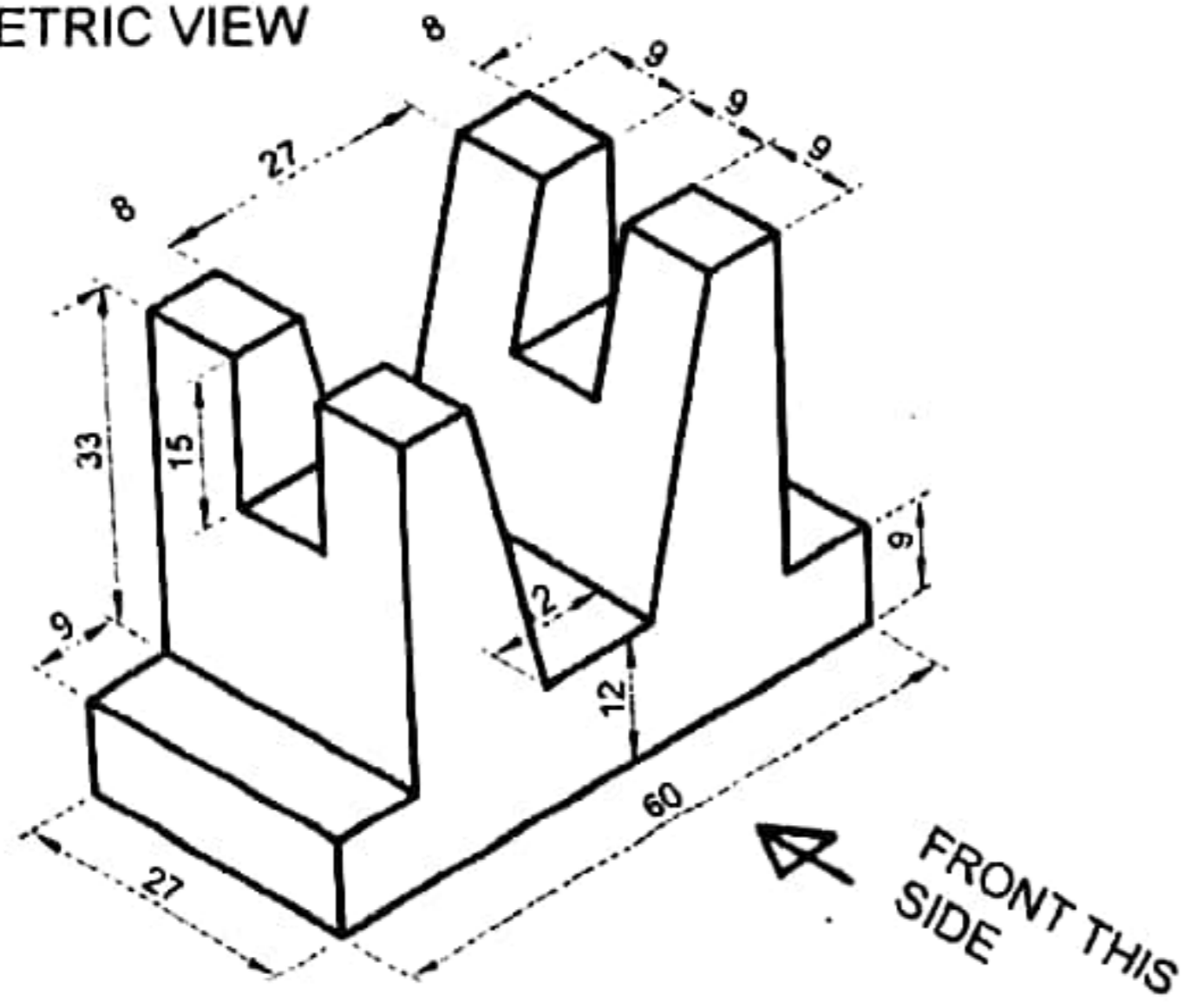

Draw the orthographic projection of solids (three plane projection) in scale 2:1 with necessary dimension. (Third angle projection)

ISOMETRIC VIEW OF GIVEN SOLIDS

TOP VIEW

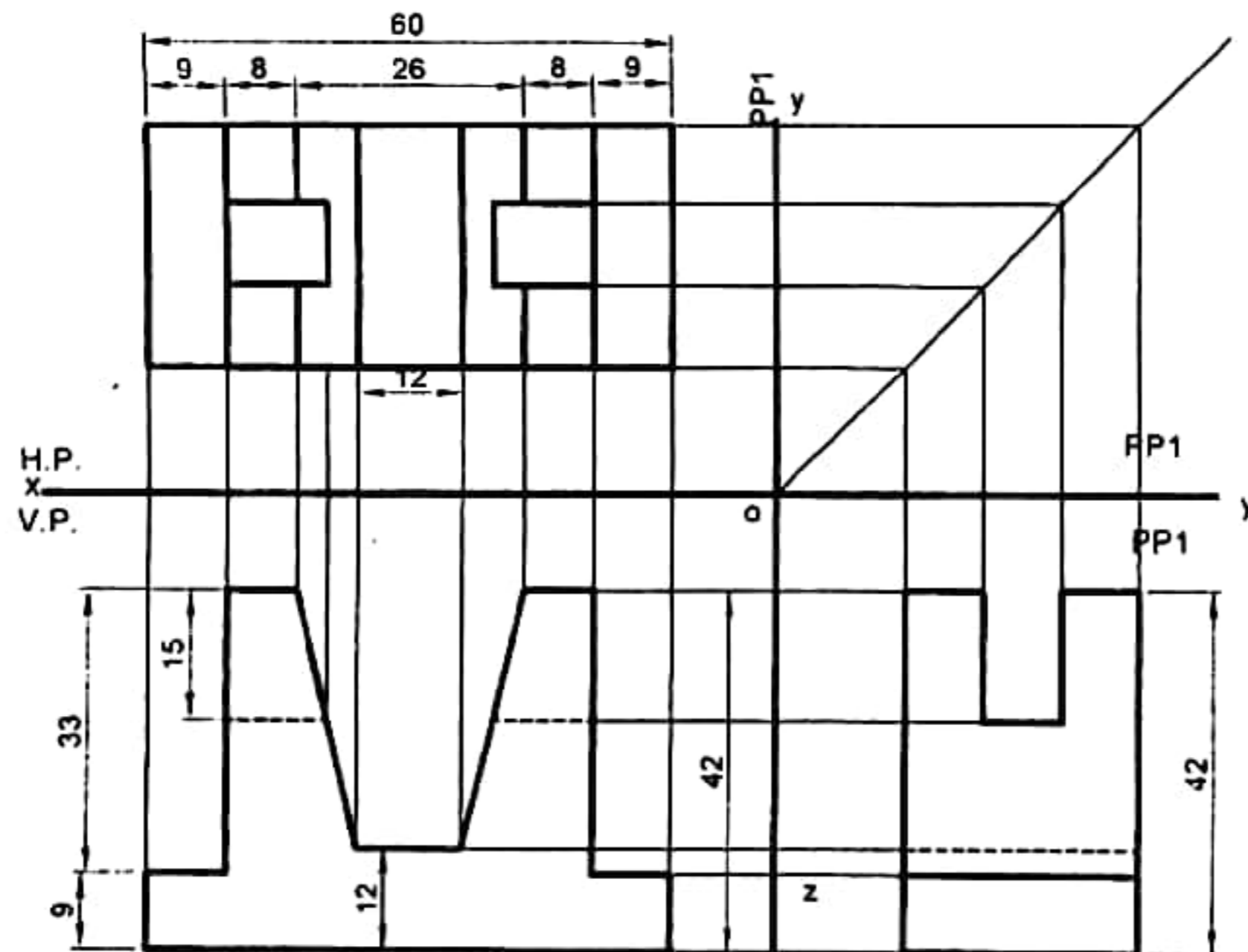

FRONT VIEW

RIGHT SIDE VIEW

ISOMETRIC VIEW

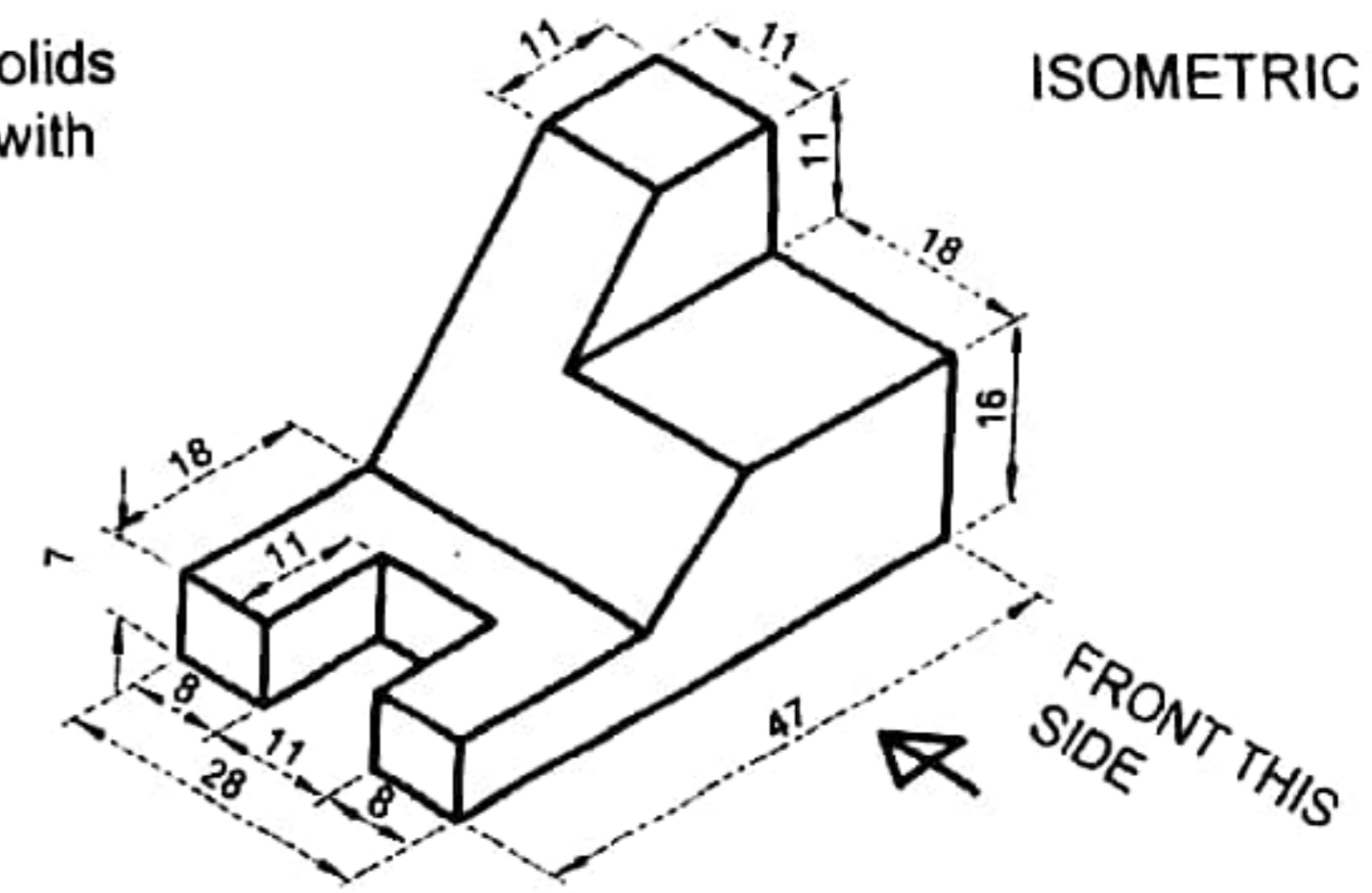

TOP VIEW

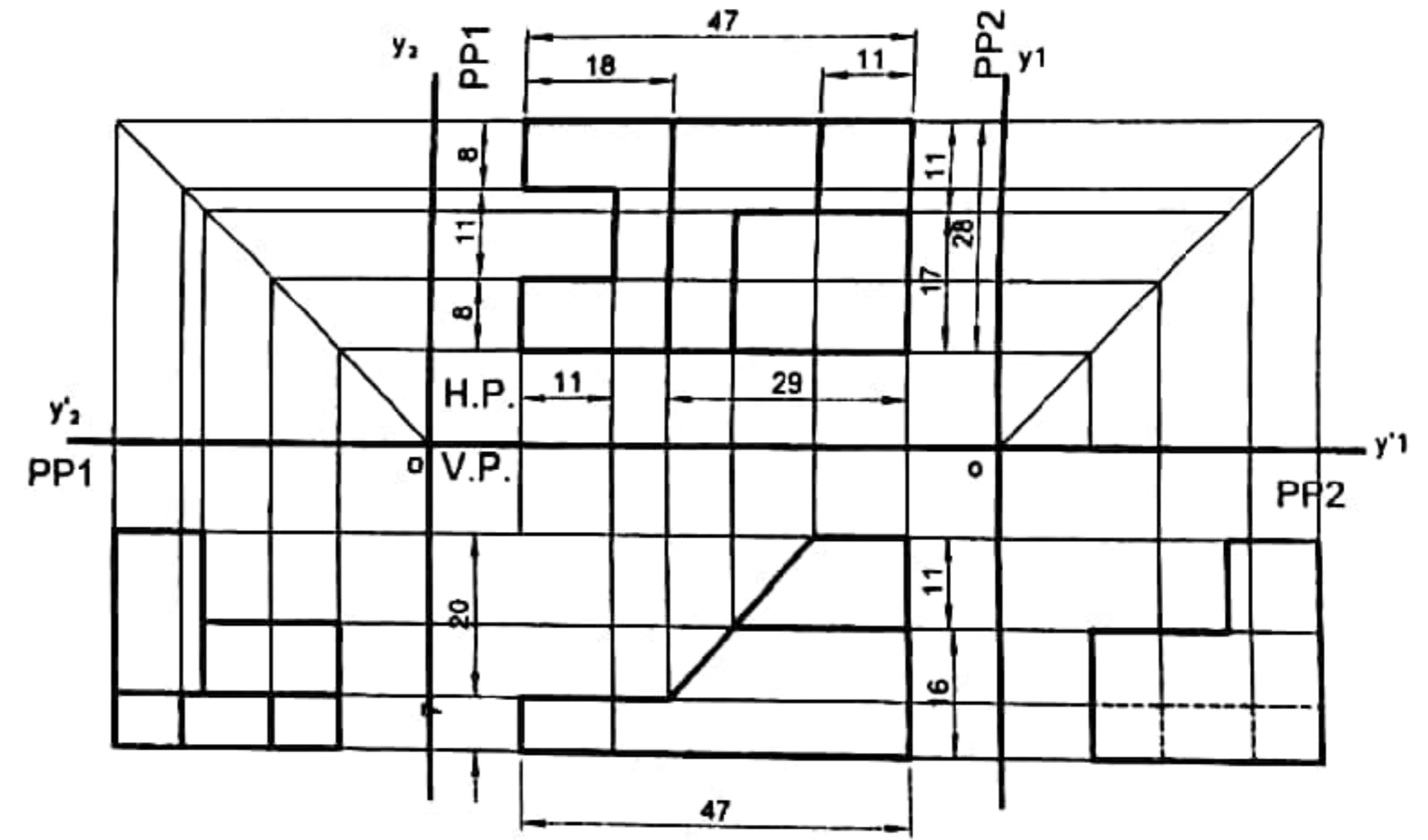

LEFT SIDE VIEW

FRONT VIEW

RIGHT SIDE VIEW

ORTHOGRAPHIC PROJECTION OF SOLIDS IN THIRD ANGLE PROJECTION

	SUBJECT	TITLE	DRAWN BY	CHECKED BY	DATE	SCALE
	ENGINEERING DRAWING	ORTHOGRAPHIC PROJECTION PROJECTION OF SOLIDS (THIRD ANGLE PROJECTION)	NAME ROLL NO			
			DATE	DRAWING NO	OP-13	

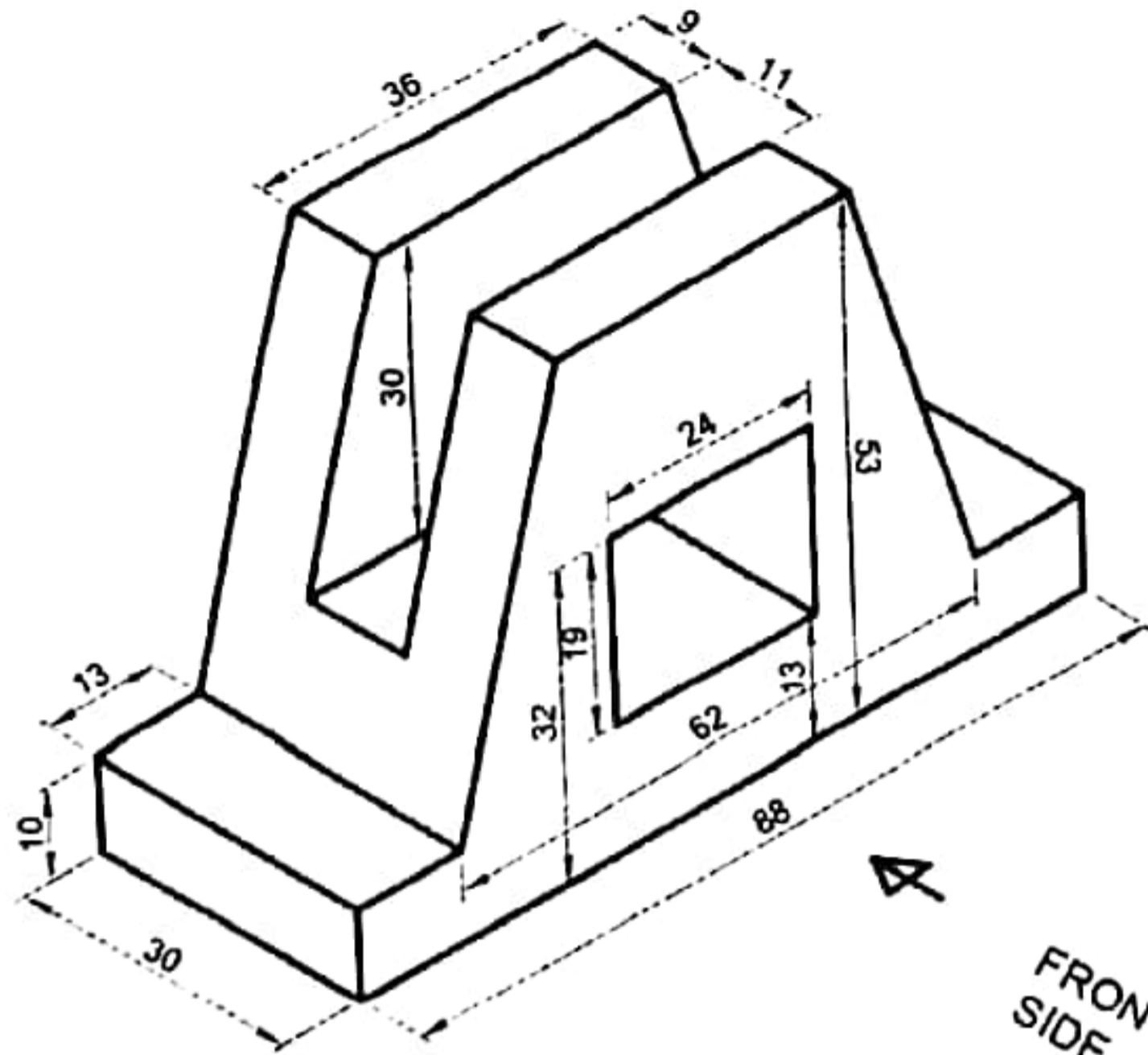

ISOMETRIC VIEW OF GIVEN SOLID

FRONT THIS SIDE

Draw the orthographic projection of solids (three plane projection) in scale 1:1 with necessary dimension. (Third angle projection)

FRONT VIEW

LEFT SIDE VIEW

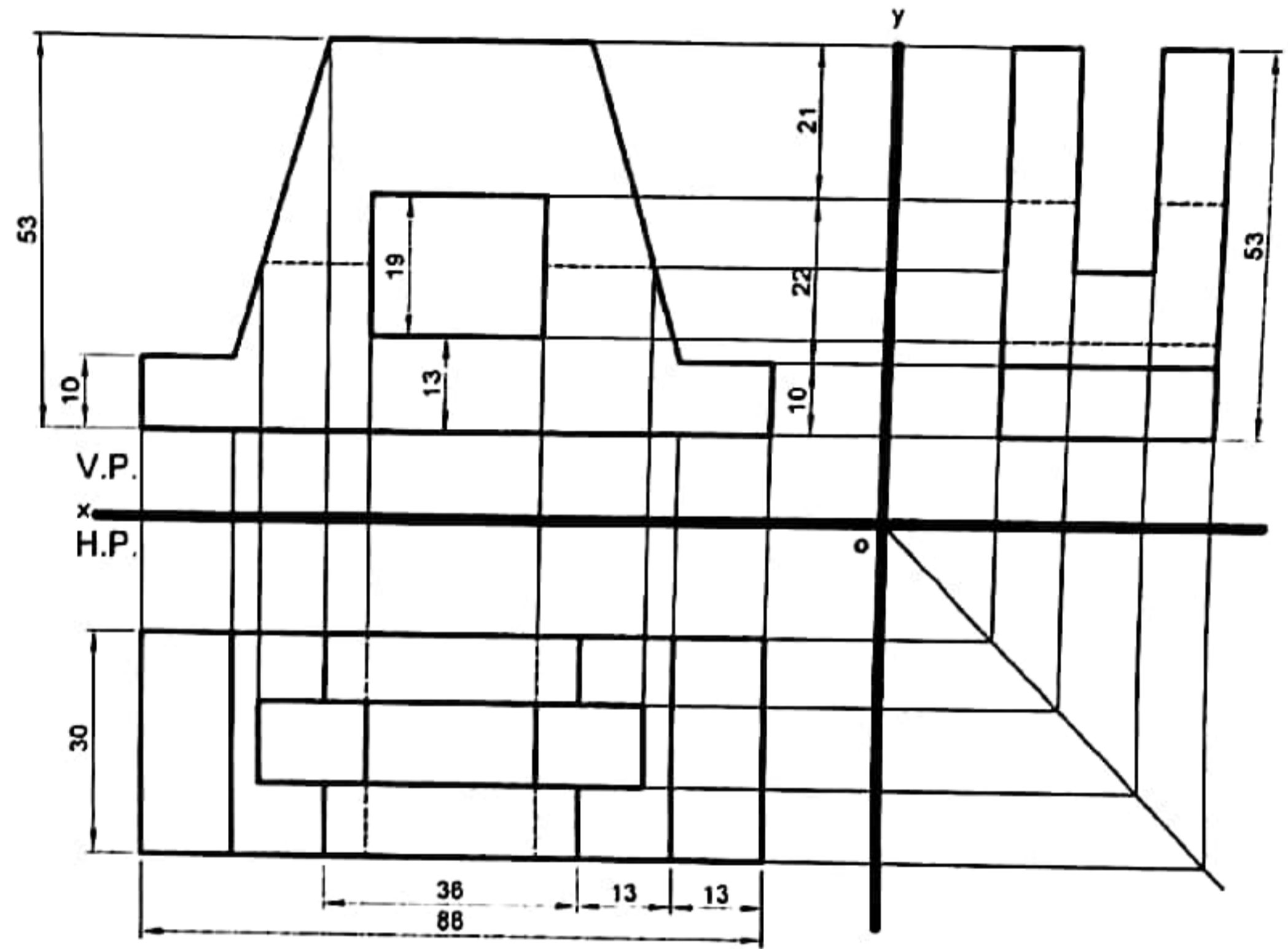

TOP VIEW

ORTHOGRAPHIC PROJECTION OF SOLIDS IN FIRST ANGLE PROJECTION

	SUBJECT	TITLE	DRAWN BY	CHECKED BY	DATE	SCALE
	ENGINEERING DRAWING	ORTHOGRAPHIC PROJECTION OF SOLIDS (FIRST ANGLE PROJECTION)	NAME ROLL NO			
				DATE	DRAWING NO	OP-14

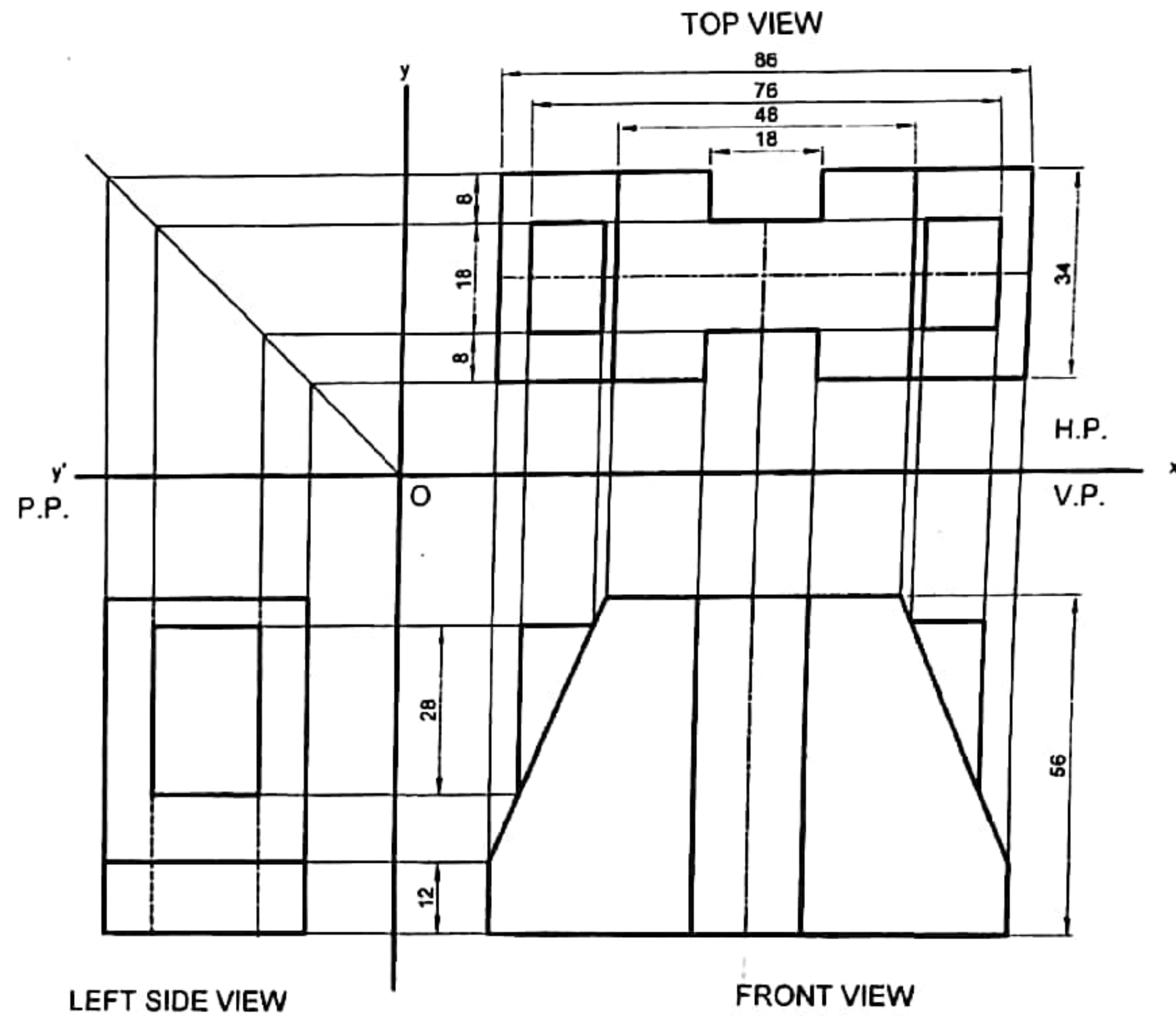
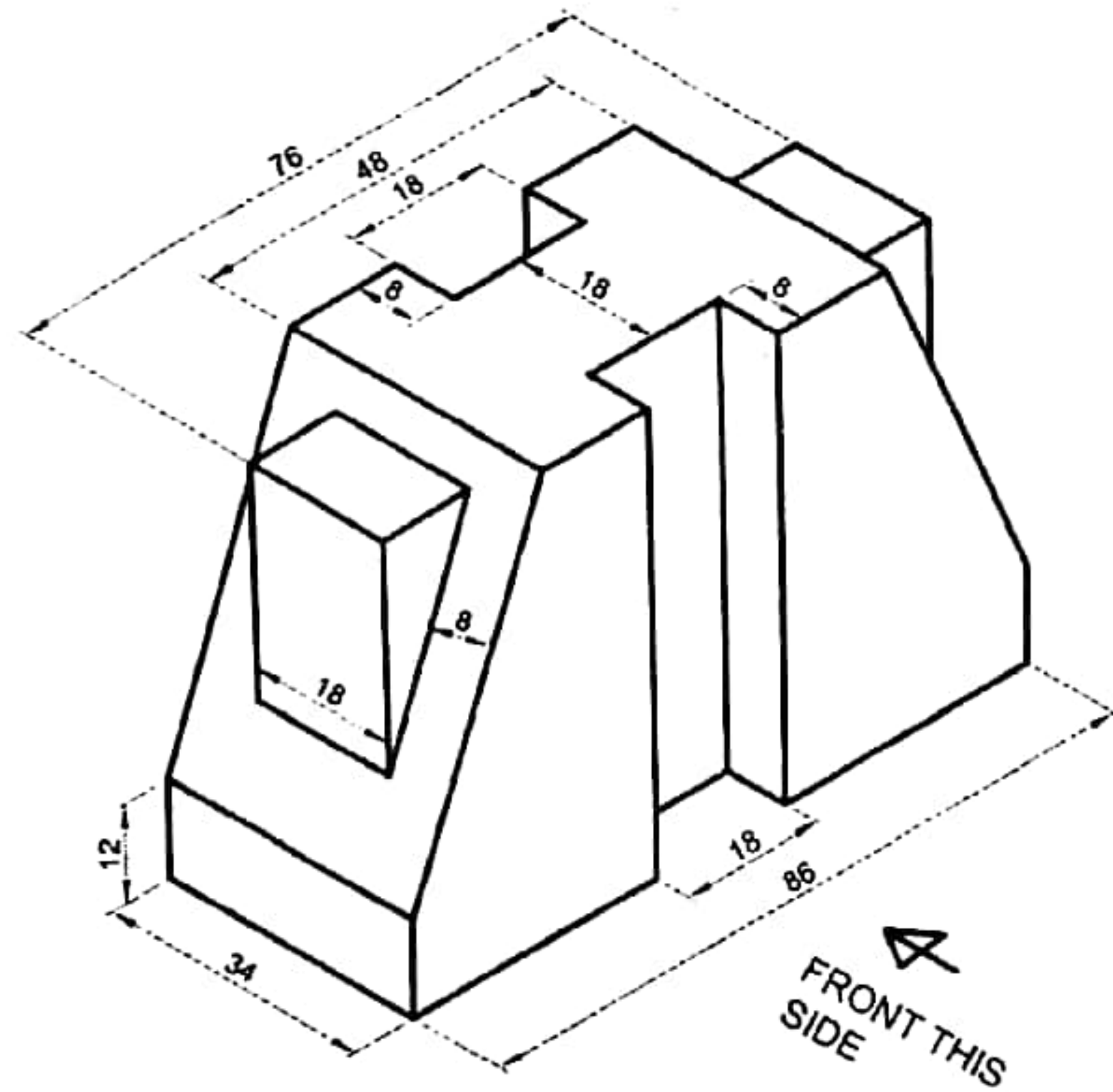

ISOMETRIC VIEW OF GIVEN SOLID

	SUBJECT	TITLE	DRAWN BY	CHECKED BY	DATE	SCALE
	ENGINEERING DRAWING	ORTHOGRAPHIC PROJECTION PROJECTION OF SOLIDS	NAME ROLL NO			
				DATE	DRAWING NO	OP-15

Draw the orthographic projection of solids
(three plane projection) in scale 2:1 with
necessary dimension. (Third angle
projection)

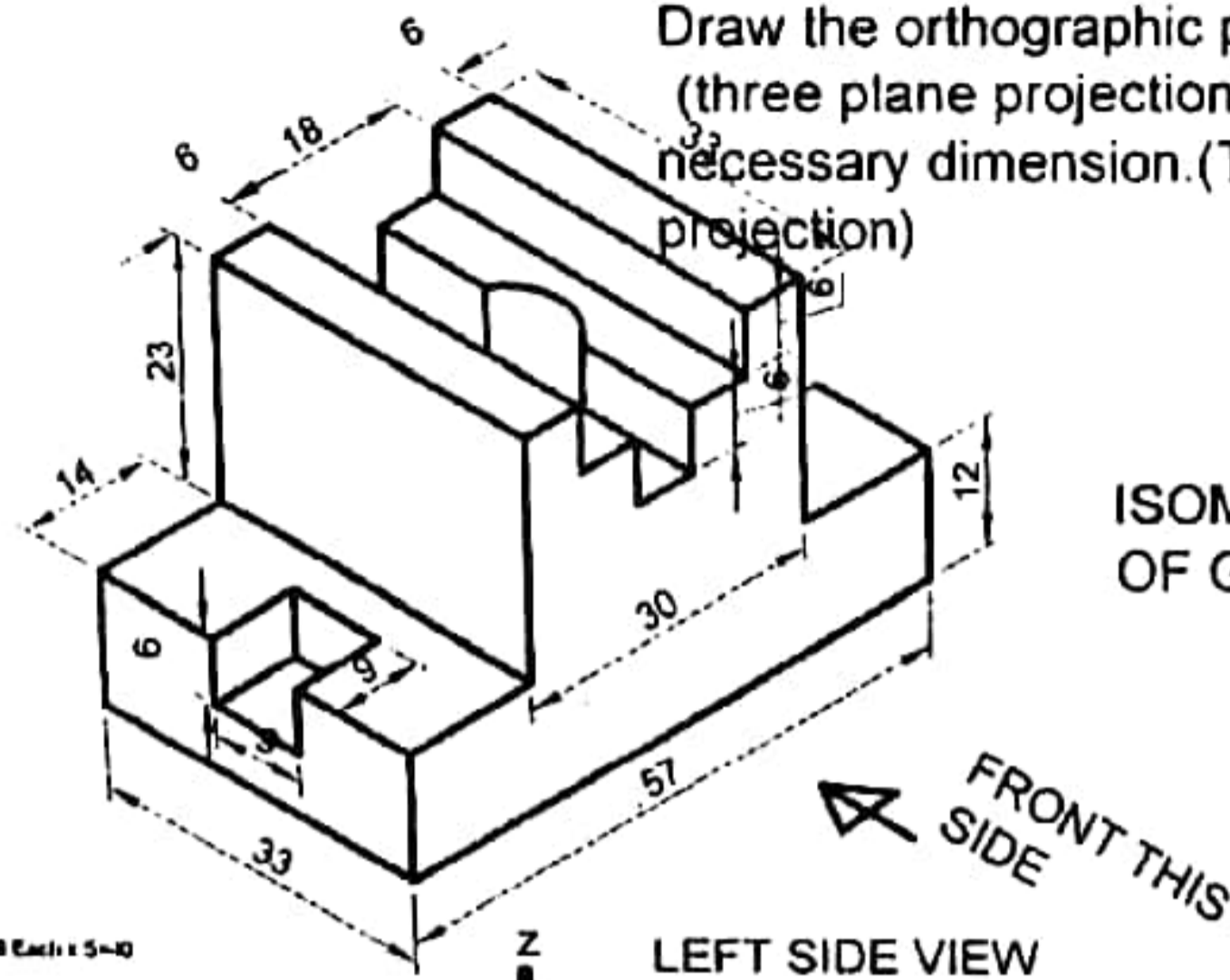

ISOMETRIC VIEW
OF GIVEN SOLIDS

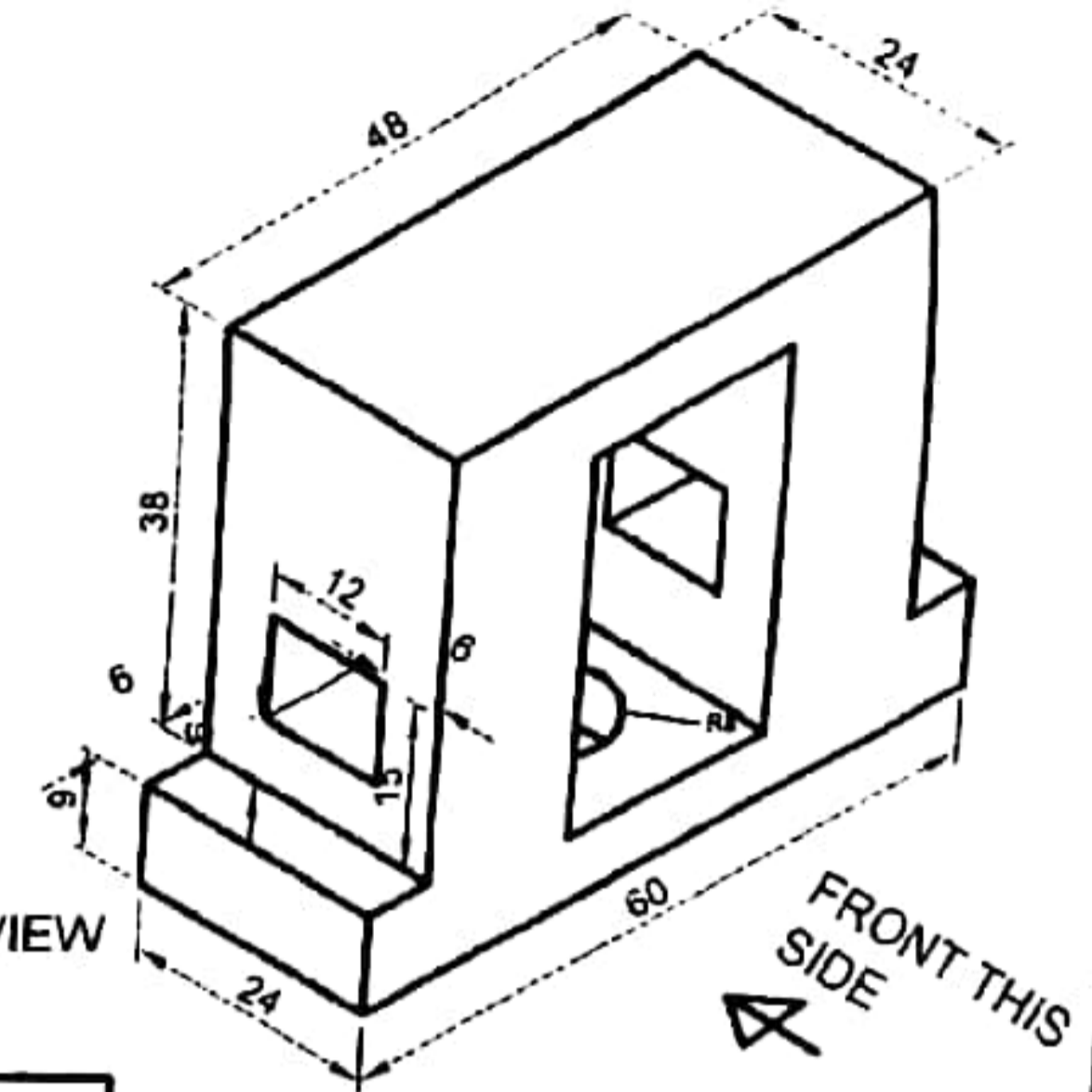

ISOMETRIC VIEW

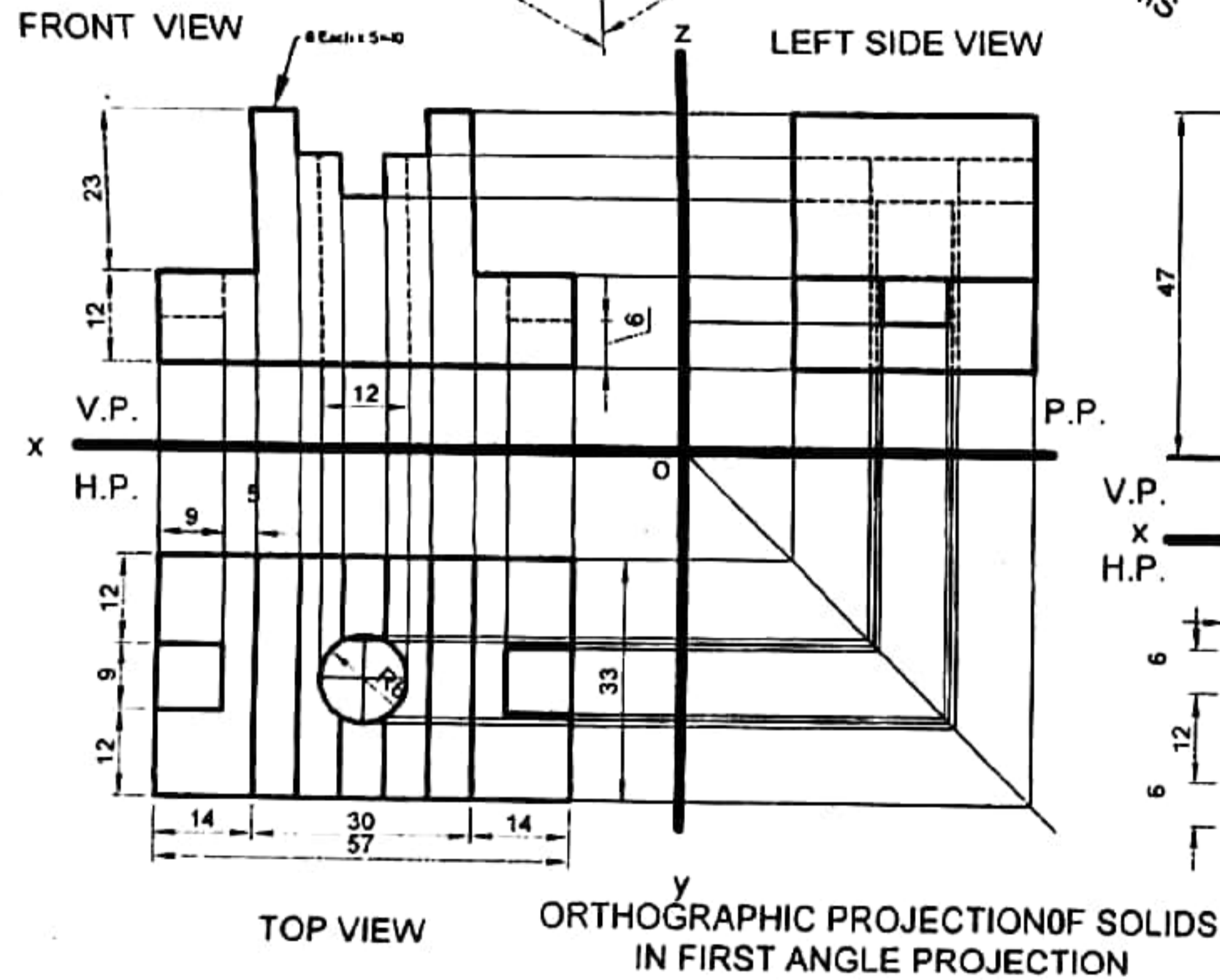

ORTHOGRAPHIC PROJECTION OF SOLIDS
IN FIRST ANGLE PROJECTION

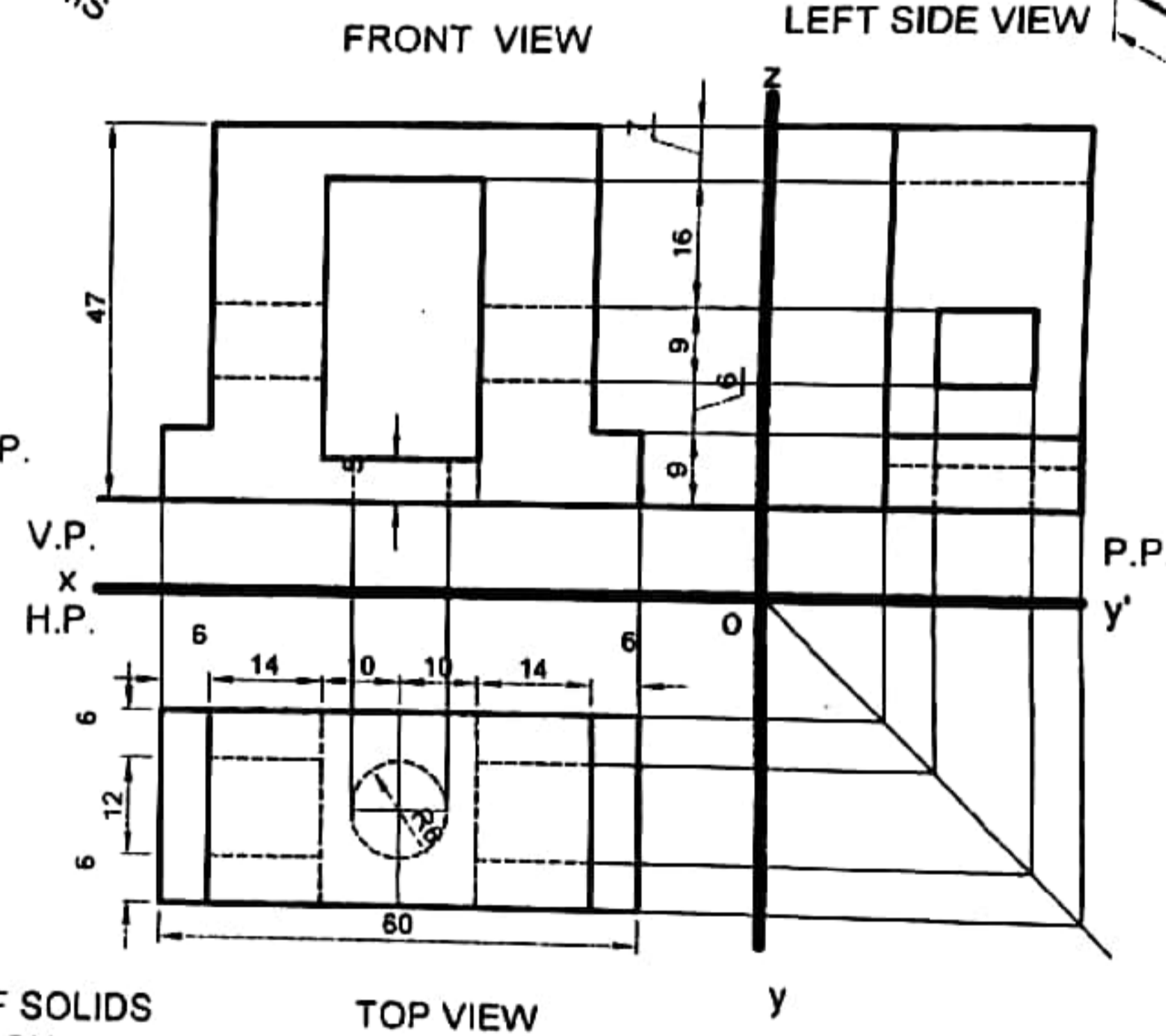

TOP VIEW

SUBJECT ENGINEERING DRAWING	TITLE ASSEMBLE DRAWING	DRAWN BY NAME ROLL NO	CHECKED BY	DATE	SCALE
				DATE	DRAWING NO OP-16

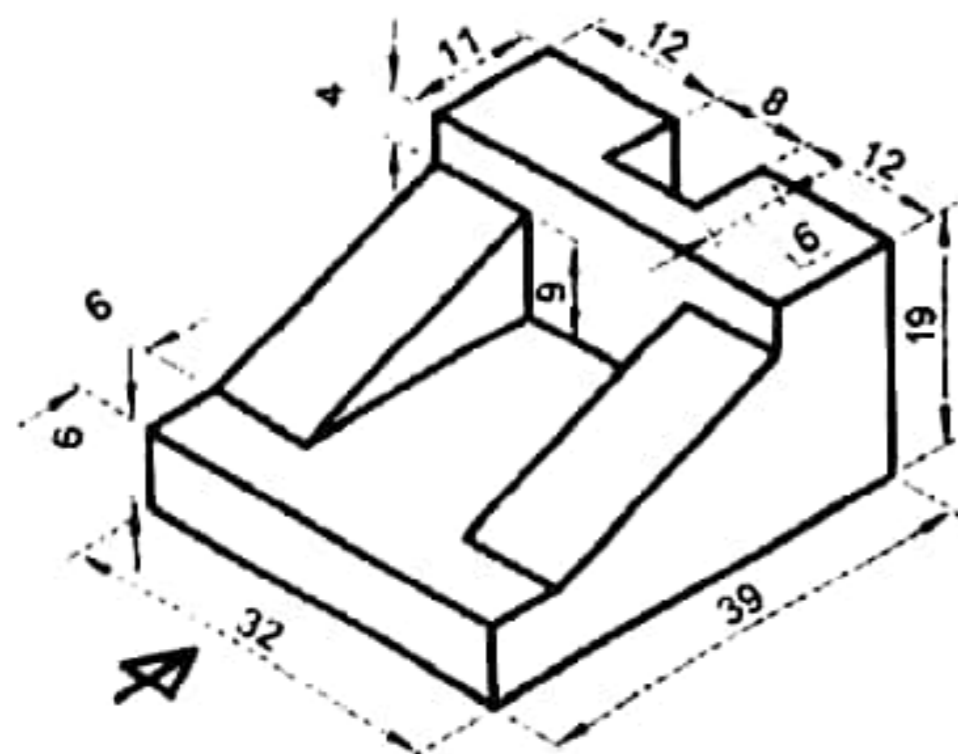

ISOMETRIC VIEW OF GIVEN SOLID

ISOMETRIC VIEW OF GIVEN SOLID

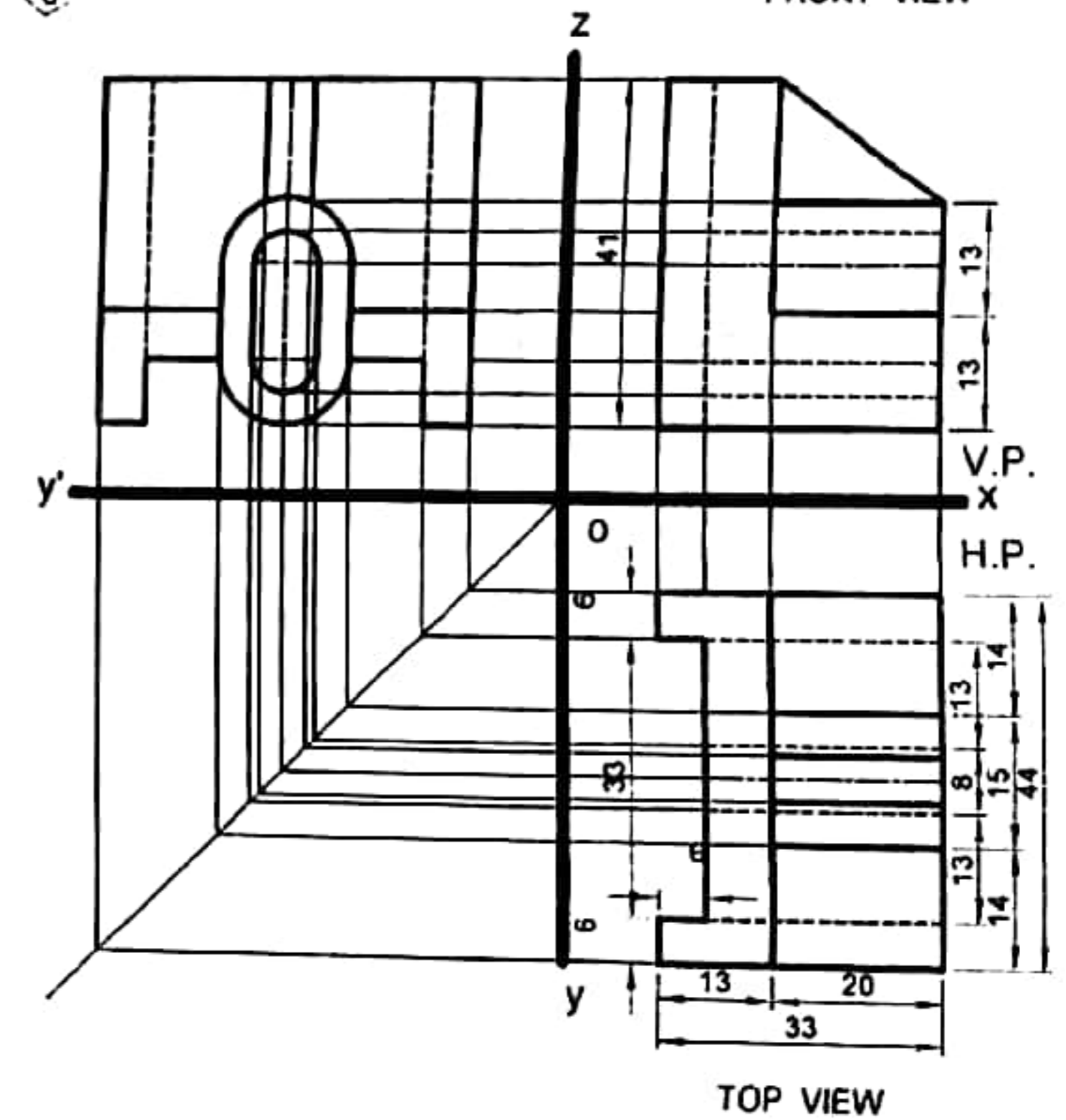
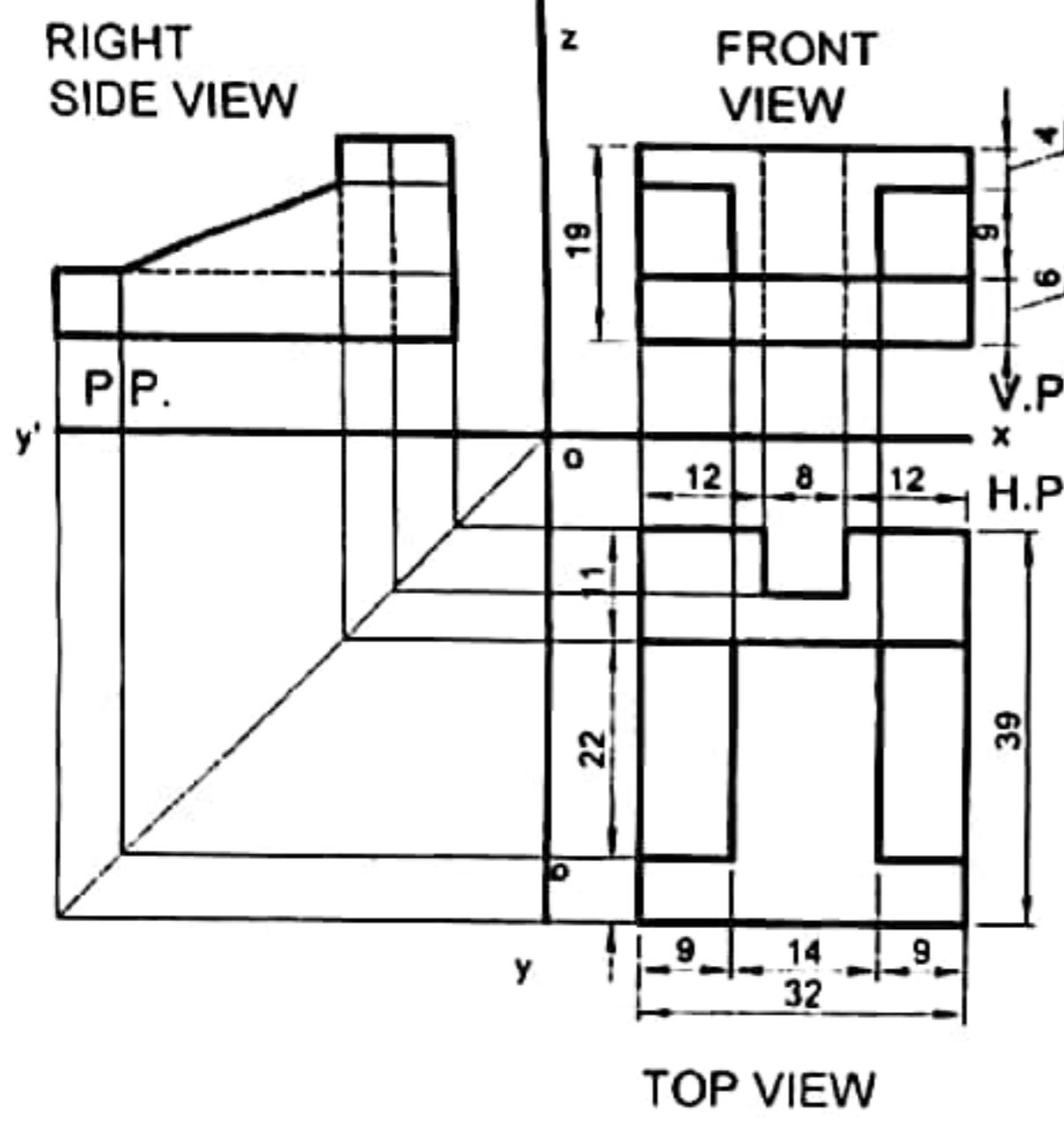
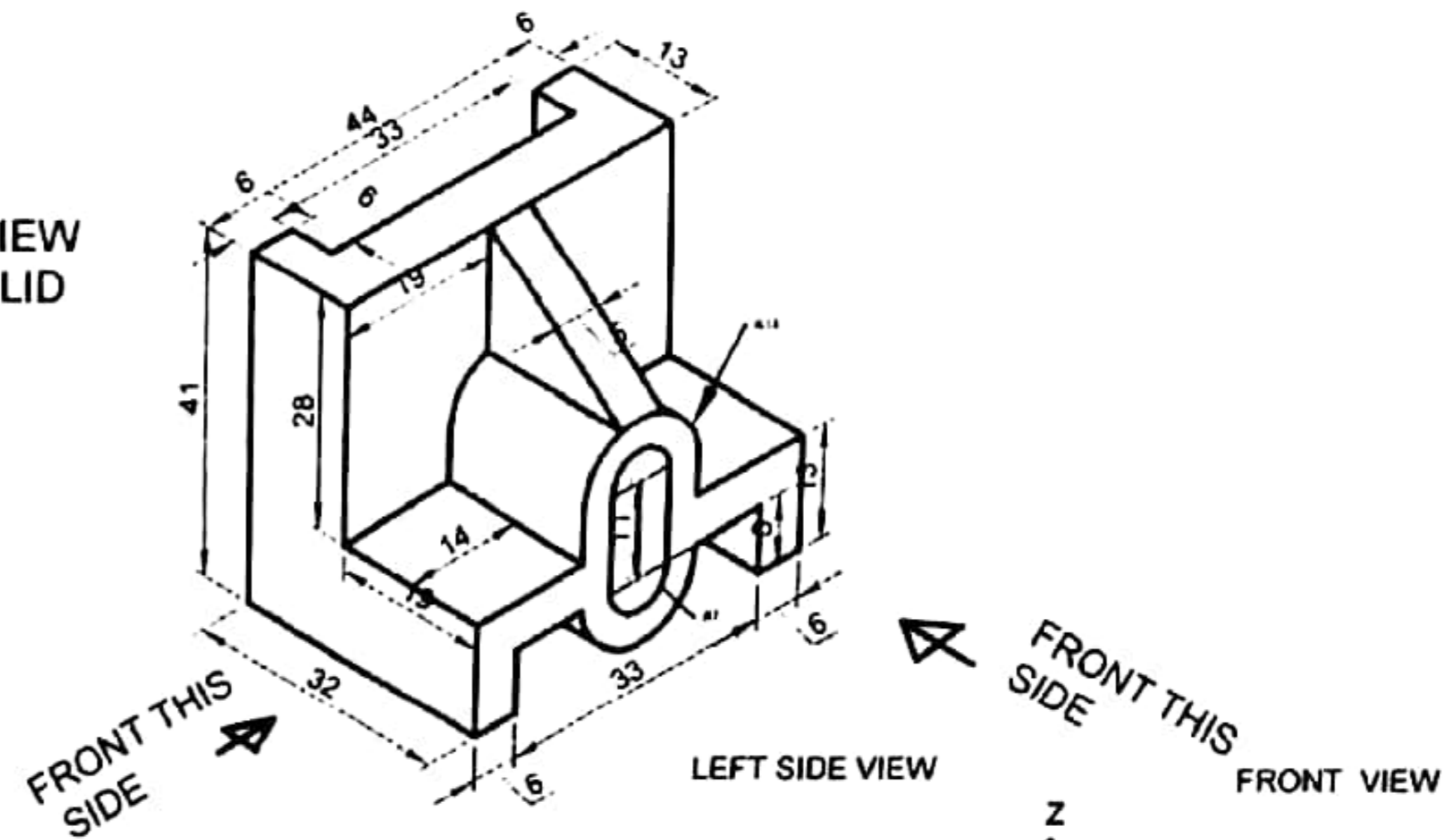

	SUBJECT	TITLE	DRAWN BY	CHECKED BY	DATE	SCALE
	ENGINEERING DRAWING	ASSEMBLE DRAWING	NAME ROLL NO			
			DATE	DRAWING NO		OP-17

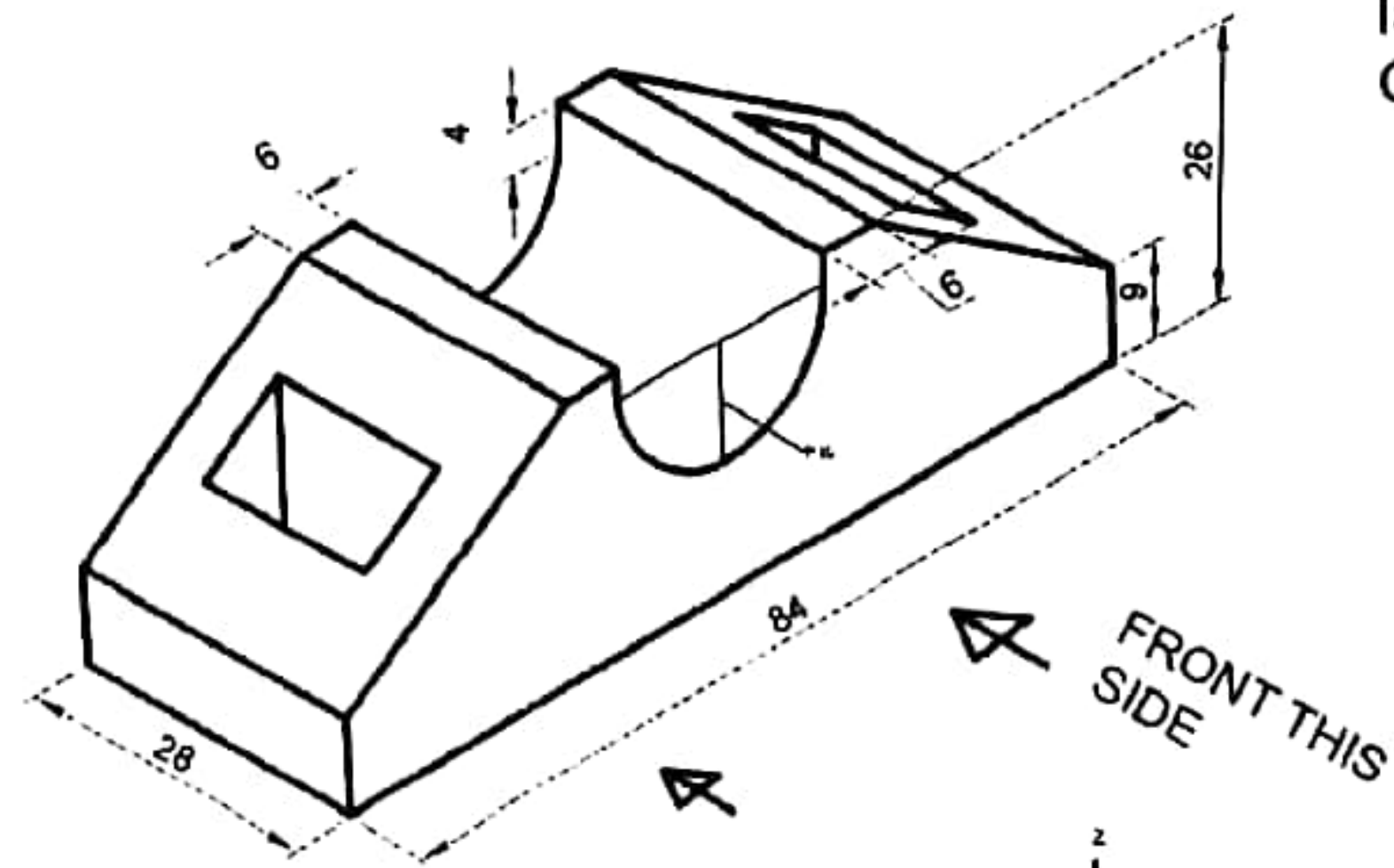

ISOMETRIC VIEW OF GIVEN SOLID

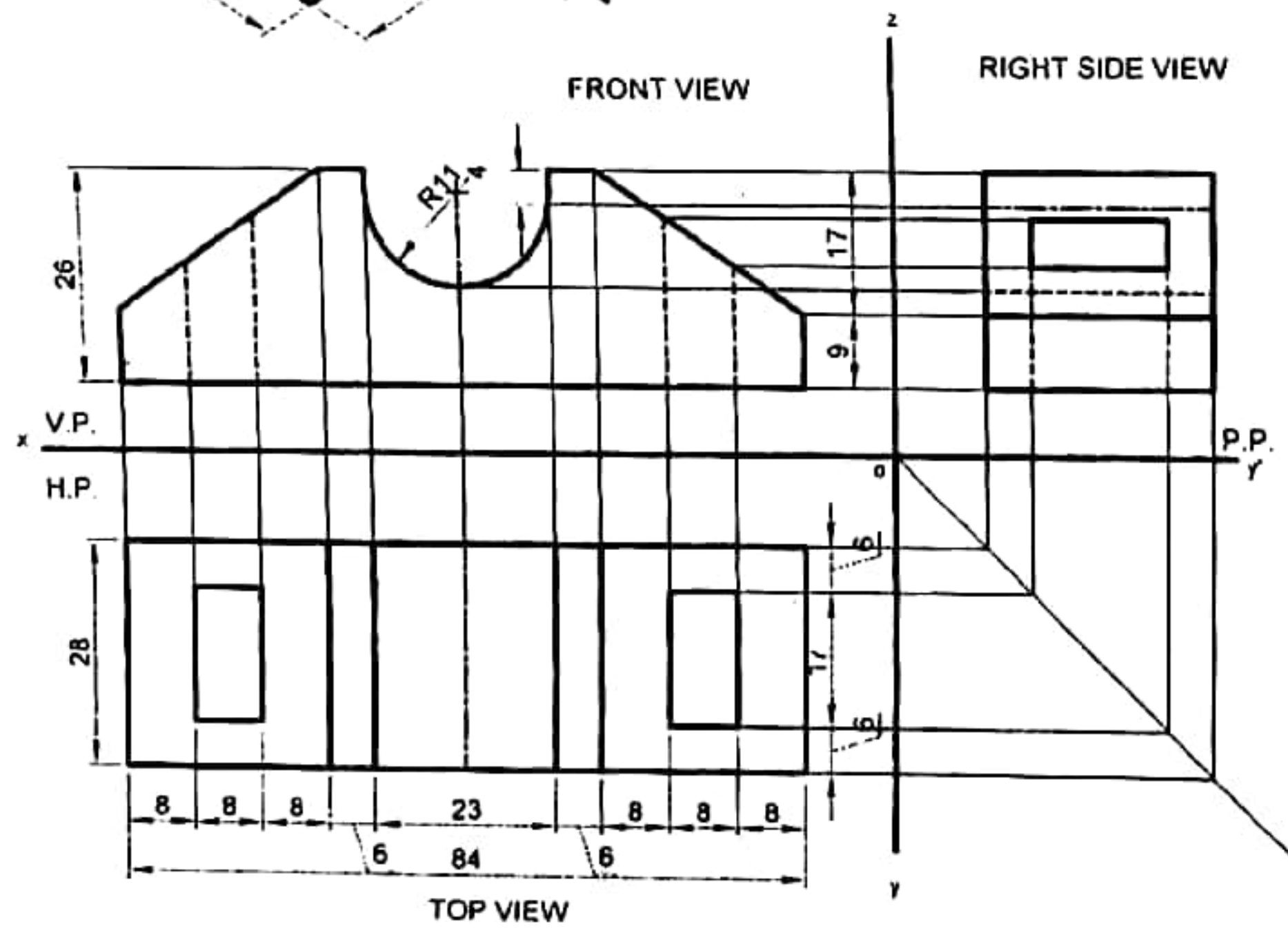
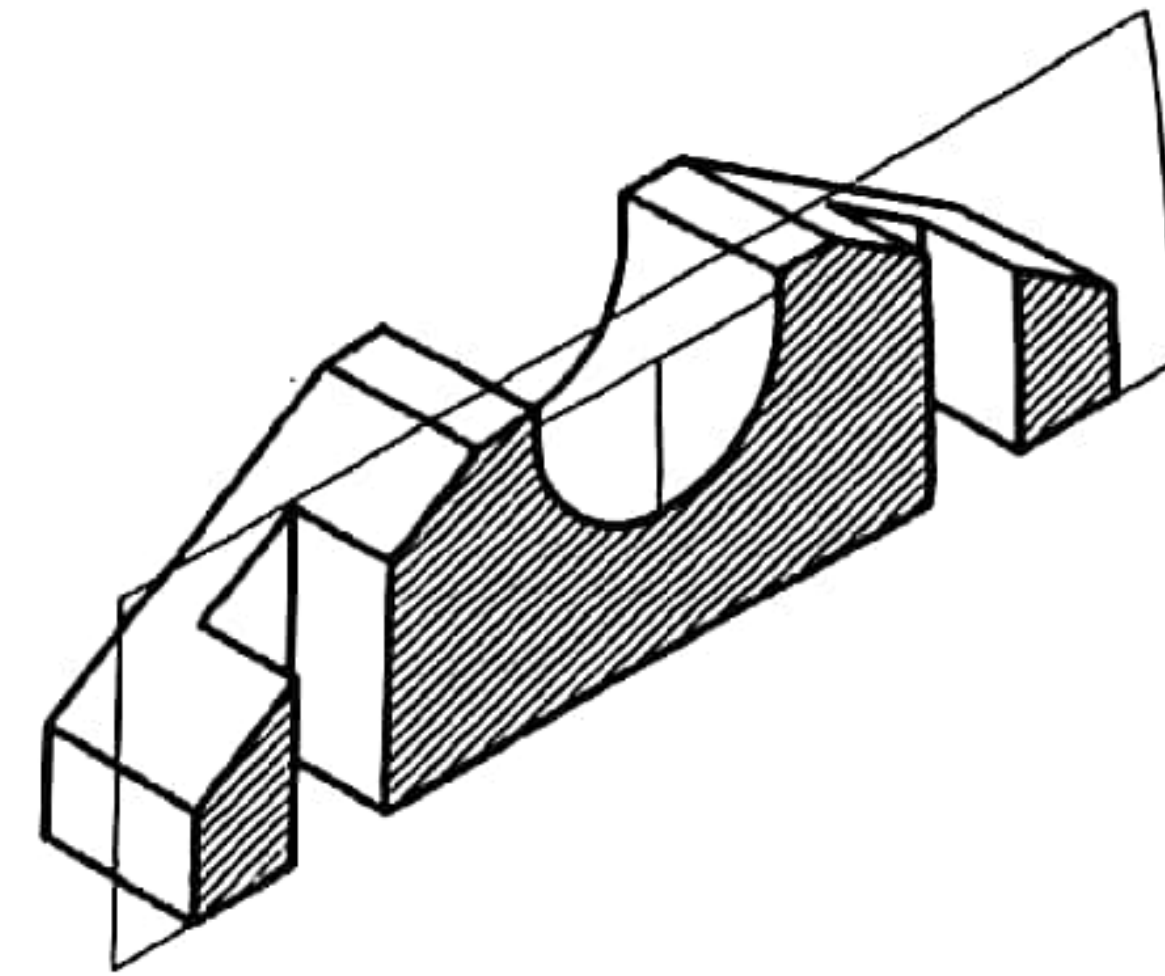

NORMAL ORTHOGRAPHIC PROJECTION OF SOLID

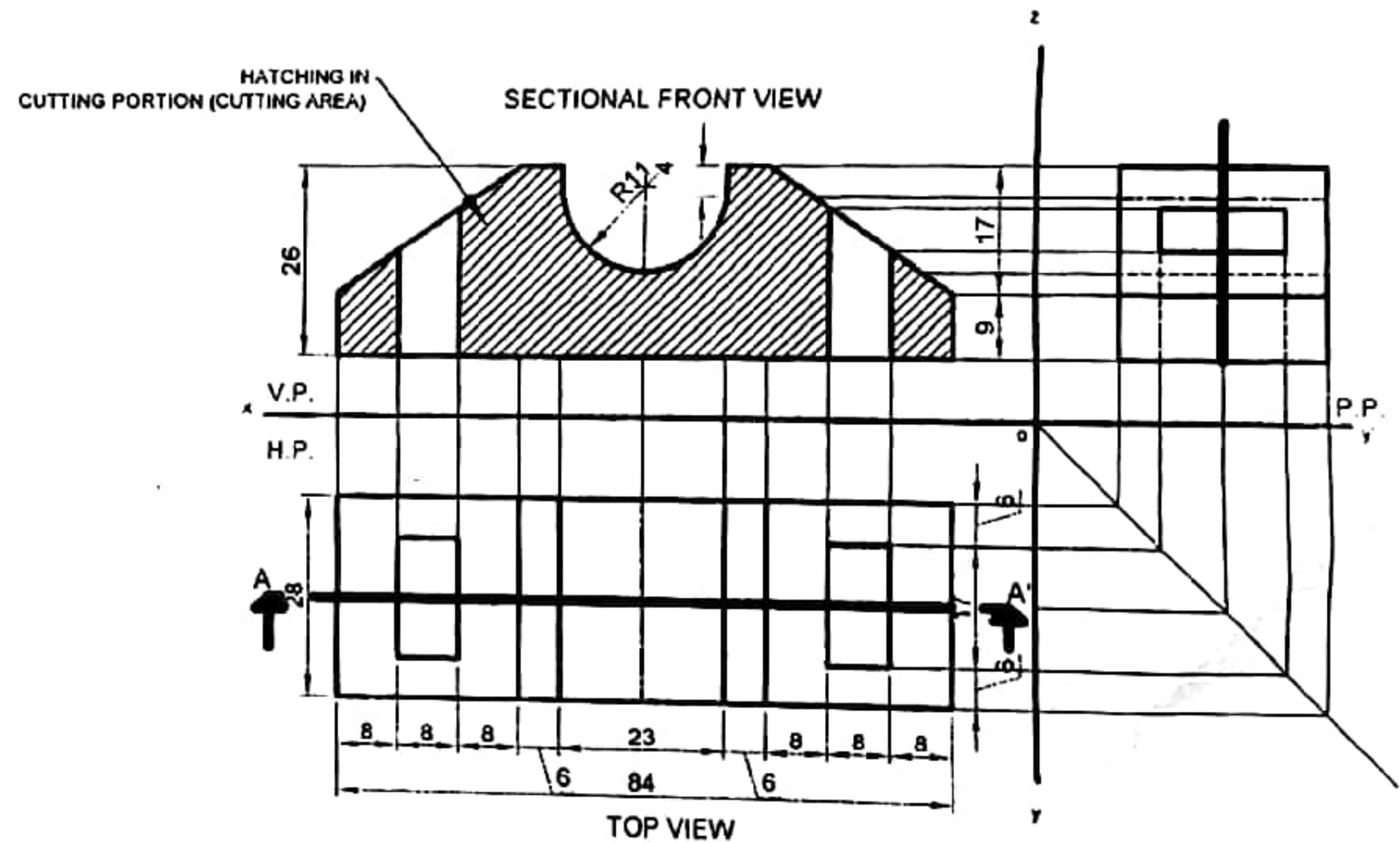

NORMAL ORTHOGRAPHIC PROJECTION OF A SOLID AFTER THE CUTTING BY A SECTIONAL PLANE NAMED A-A' WHICH IS PERPENDICULAR TO HP AND PARALLEL TO VP. (HORIZONTAL PROJECTING PLANE)

	SUBJECT	TITLE	DRAWN BY	CHECKED BY	DATE	SCALE
	ENGINEERING DRAWING	SECTION ORTHOGRAPHIC PROJECTION SHOWING THE FULL AND HALF SECTIONAL VIEW	NAME ROLL NO			
				DATE	DRAWING NO 40	

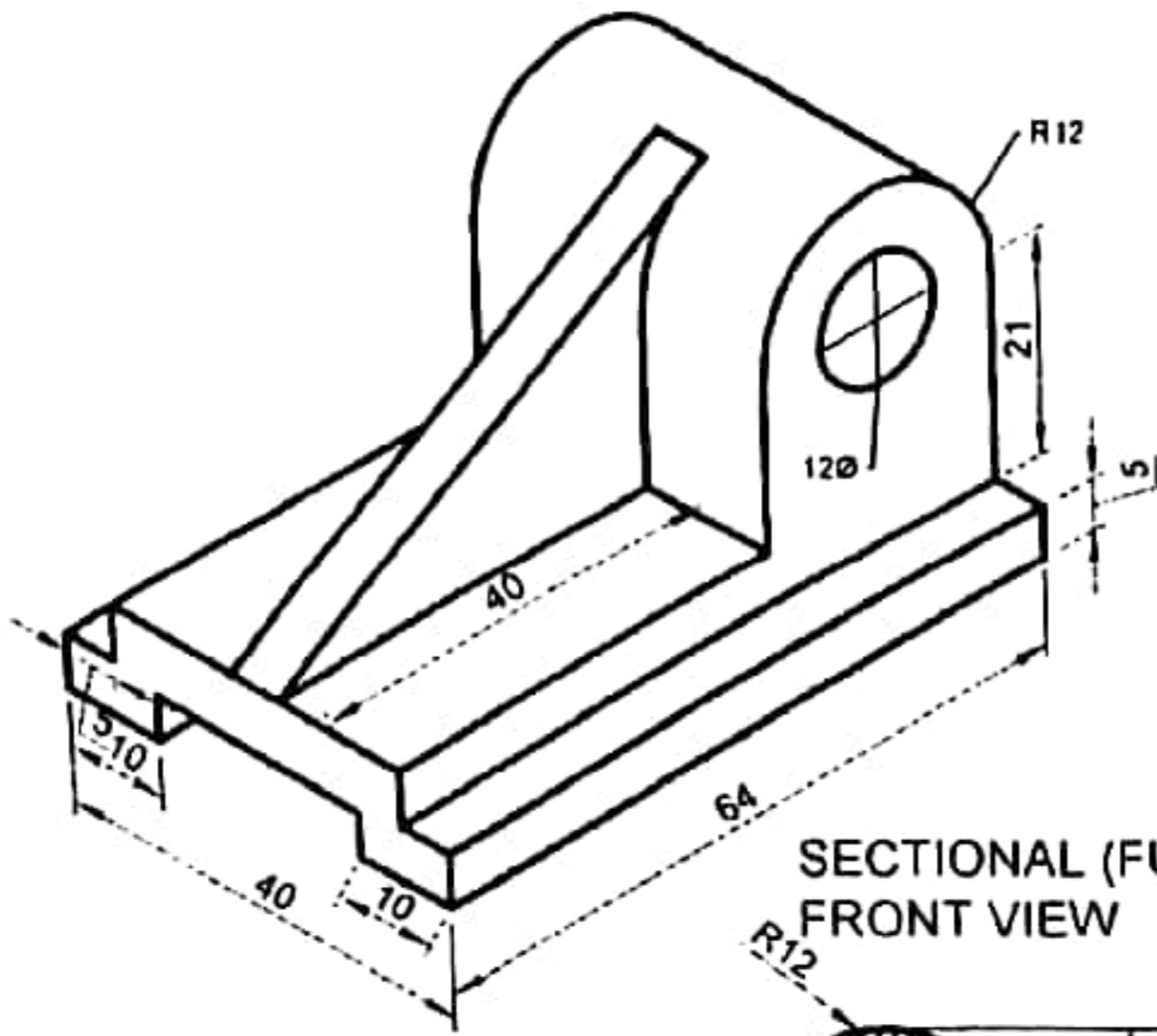

ISOMETRIC VIEW OF GIVEN SOLIDS

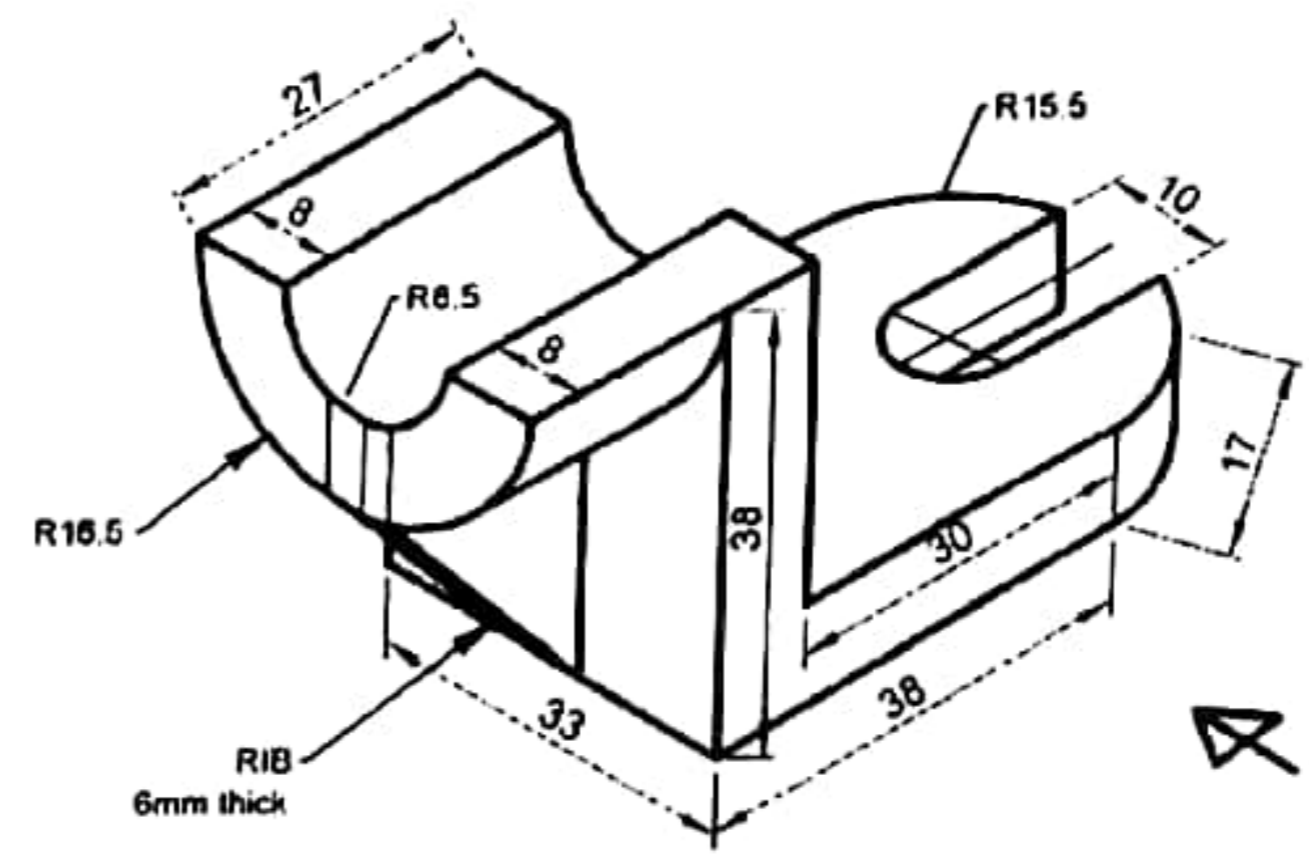

FRONT THIS SIDE

FRONT THIS SIDE

SECTIONAL (FULL) FRONT VIEW

RIGHT SIDE VIEW

SECTIONAL FRONT VIEW

RIGHT SIDE VIEW

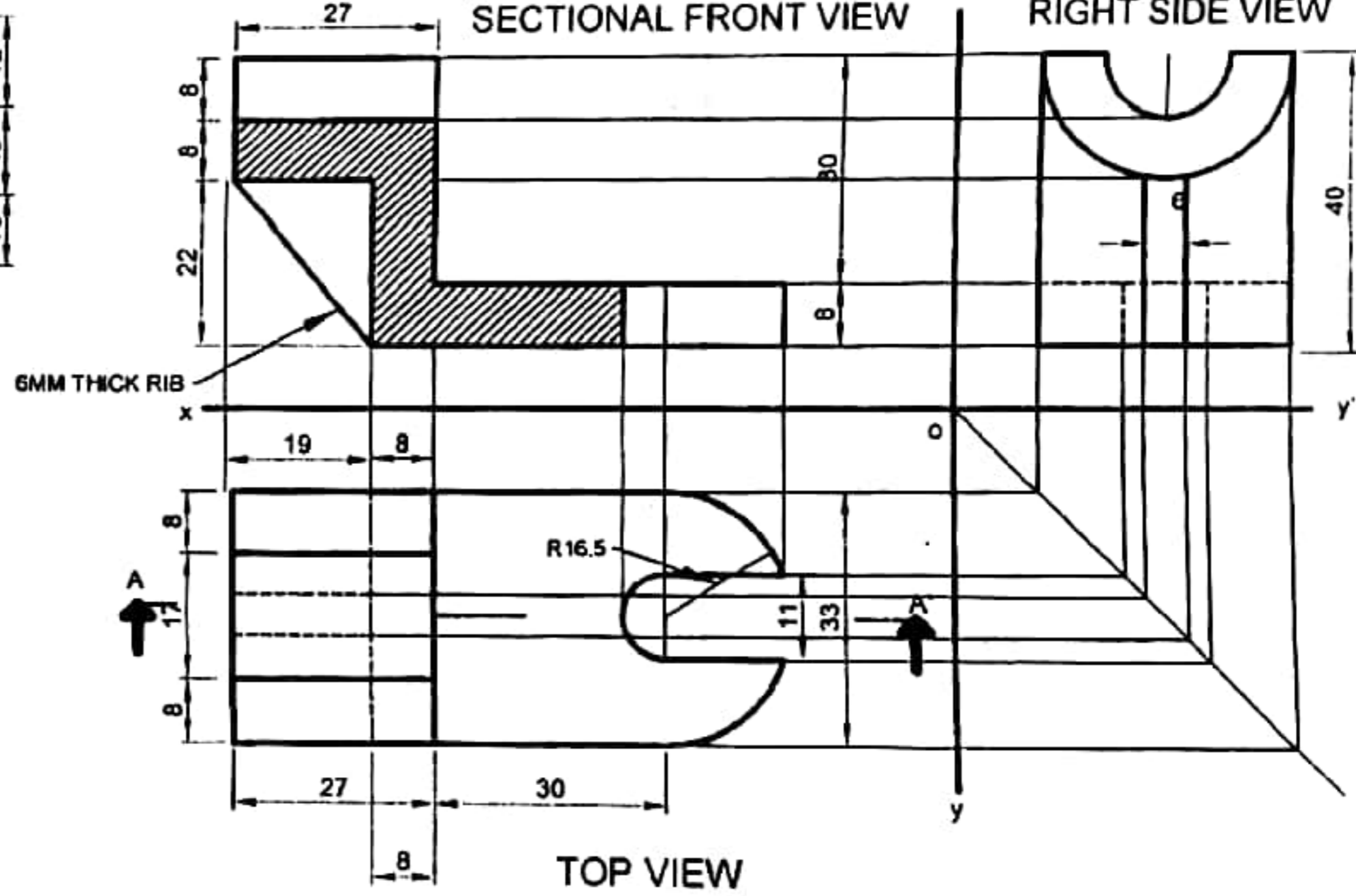
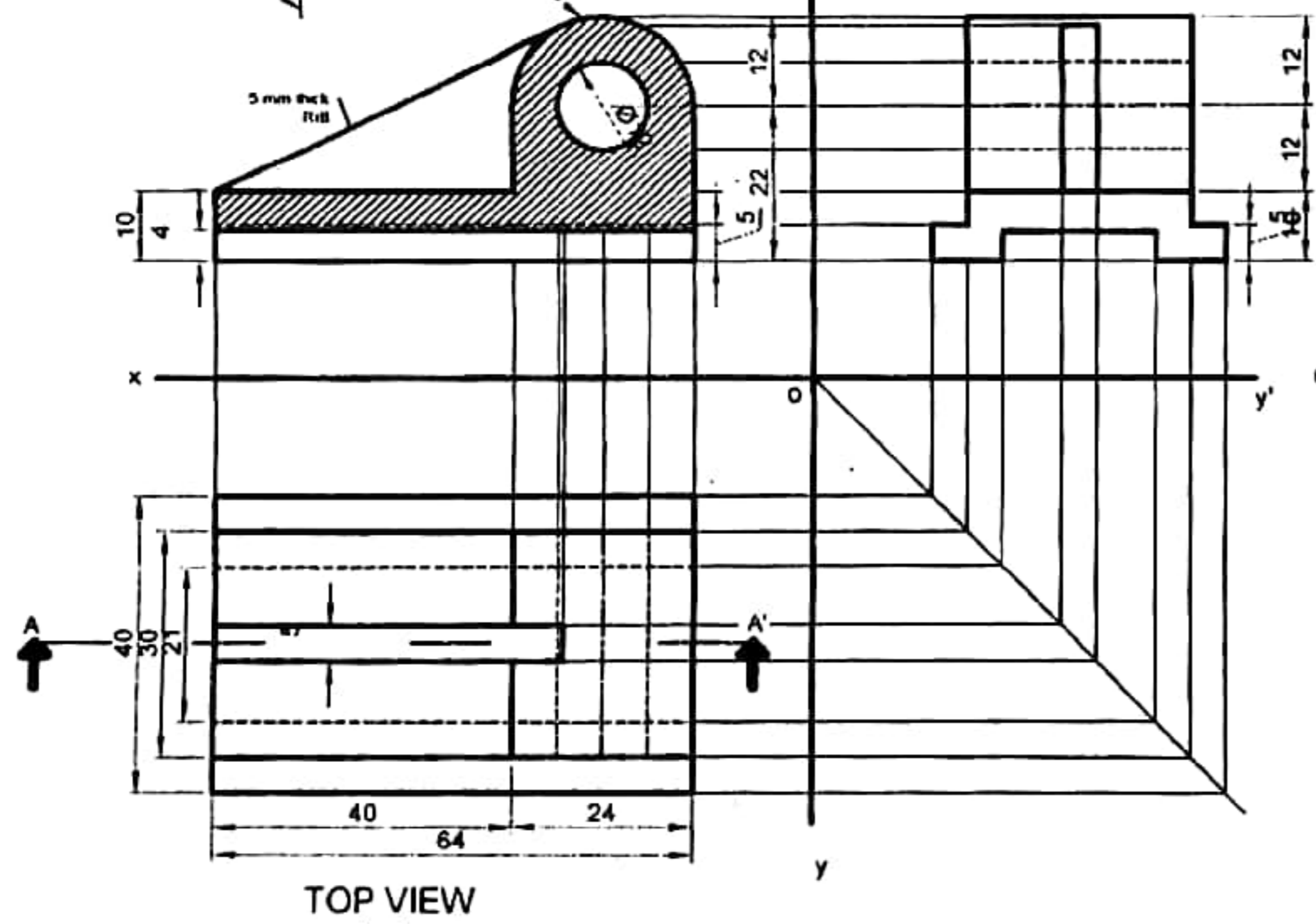

SUBJECT ENGINEERING DRAWING	TITLE SECTION ORTHOGRAPHIC PROJECTION SHOWING THE FULL AND HALF SECTIONAL VIEW	DRAWN BY NAME ROLL NO	CHECKED BY	DATE	SCALE
				DATE	DRAWING NO 41

FRONT VIEW

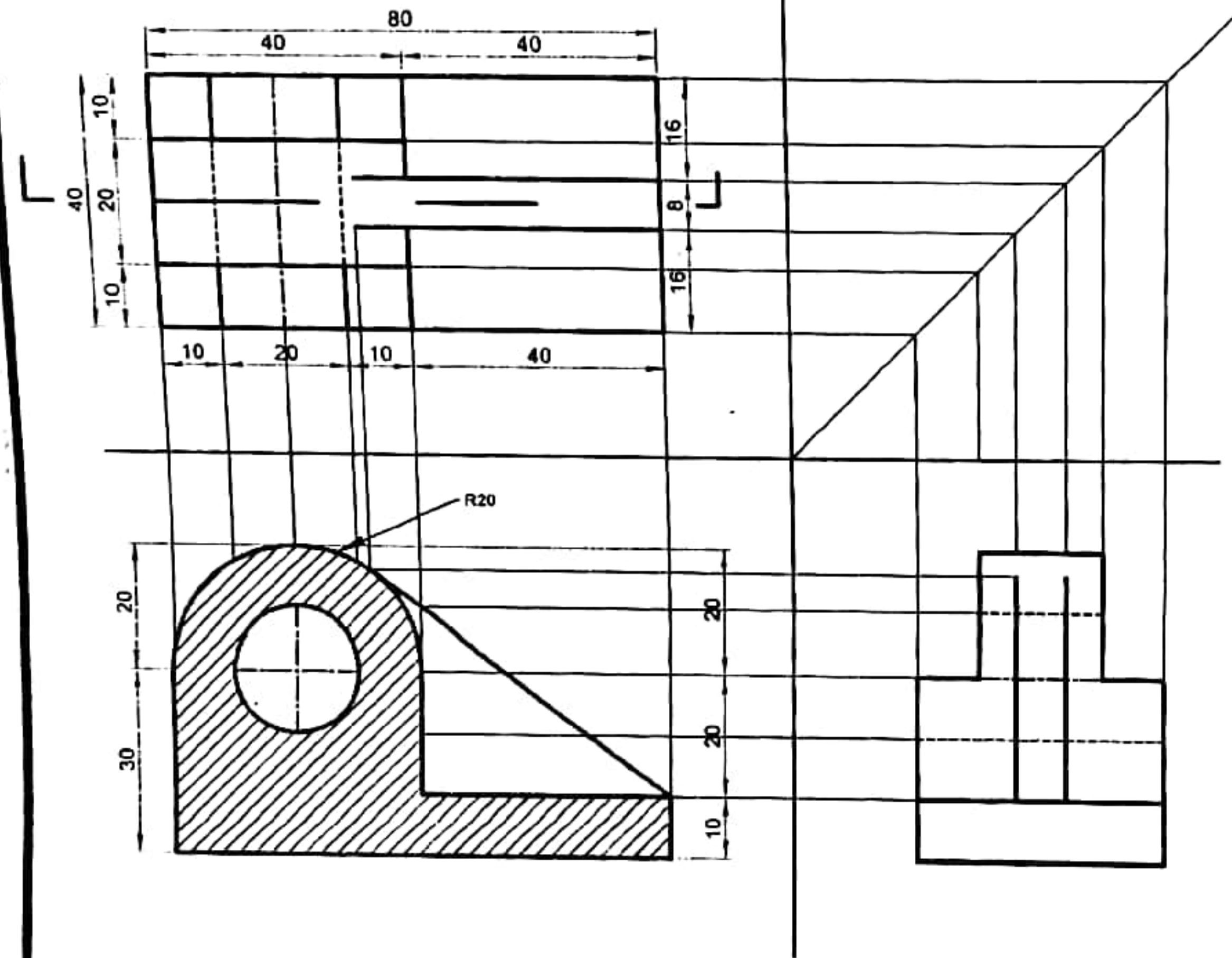

TOP VIEW

RIGHT SIDE VIEW

ISOMETRIC VIEW OF GIVEN SOLID

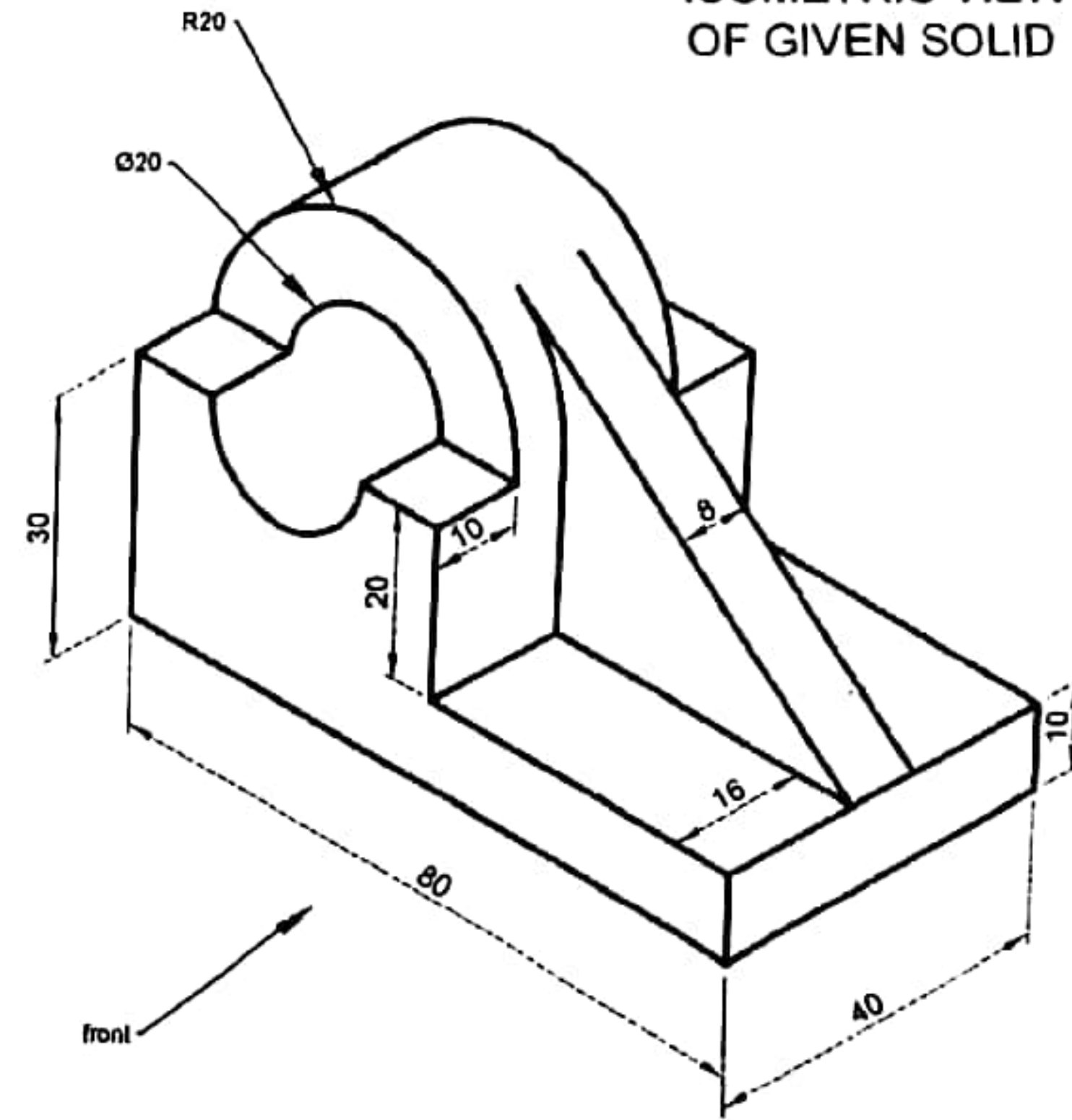

	SUBJECT	TITLE	DRAWN BY	CHECKED BY	DATE	SCALE
	ENGINEERING DRAWING		NAME ROLL NO			
				DATE	DRAWING NO 42	

RIGHT SIDE VIEW

FRONT VIEW

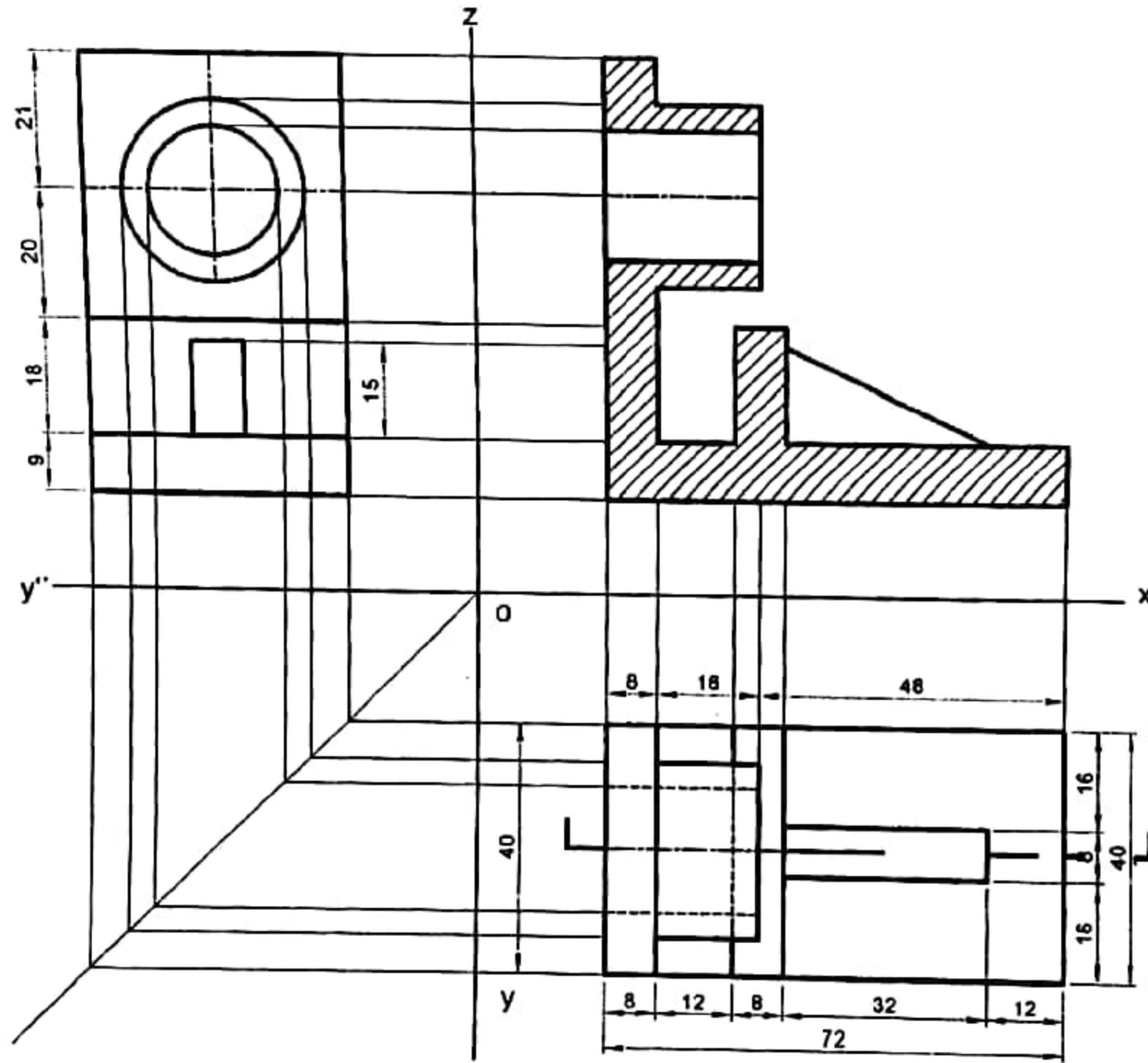

ISOMETRIC VIEW OF GIVEN SOLID

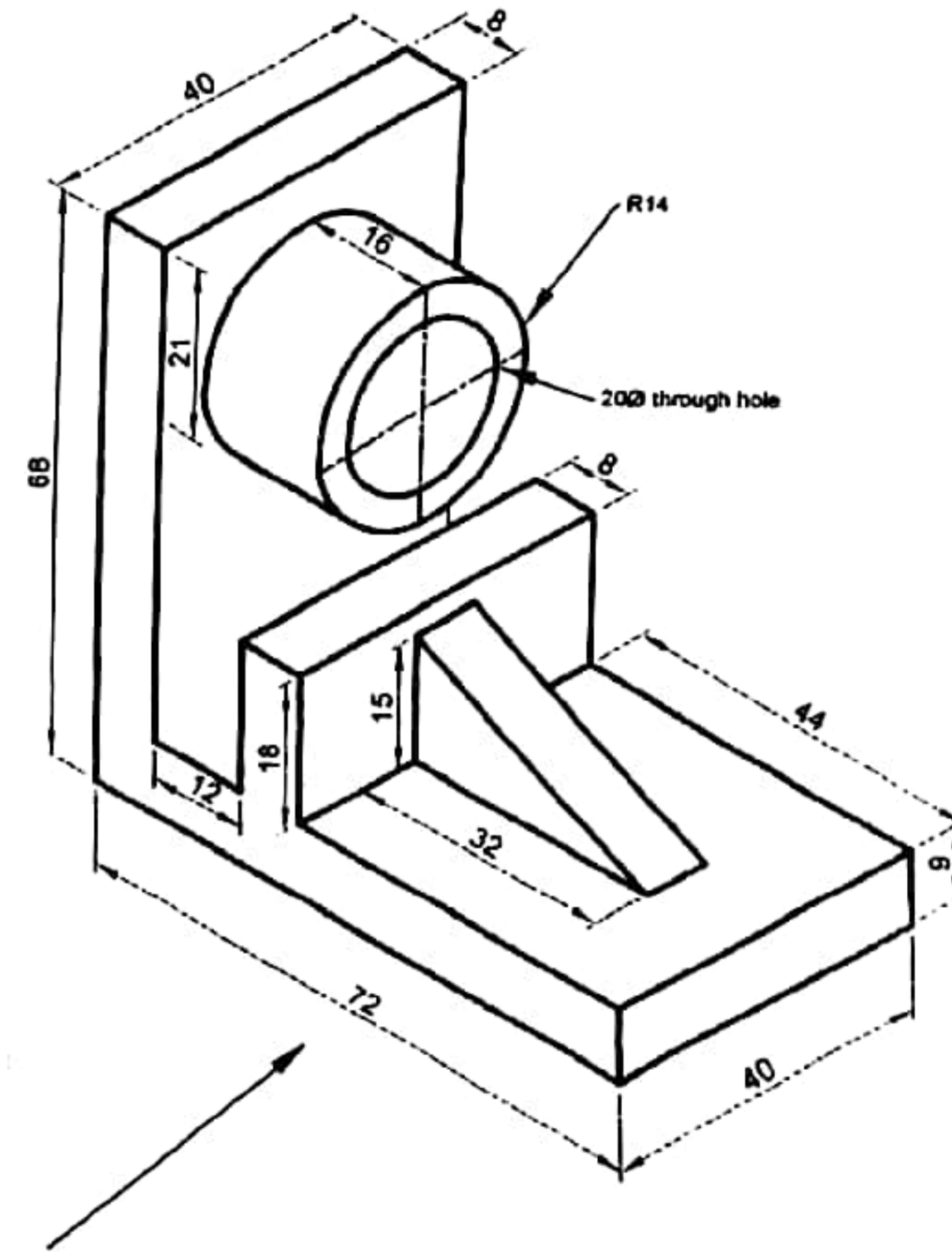

TOP VIEW

SUBJECT ENGINEERING DRAWING	TITLE	DRAWN BY NAME ROLL NO	CHECKED BY	DATE	SCALE
				DATE	DRAWING NO 43

ISOMETRIC VIEW OF GIVEN SOLID

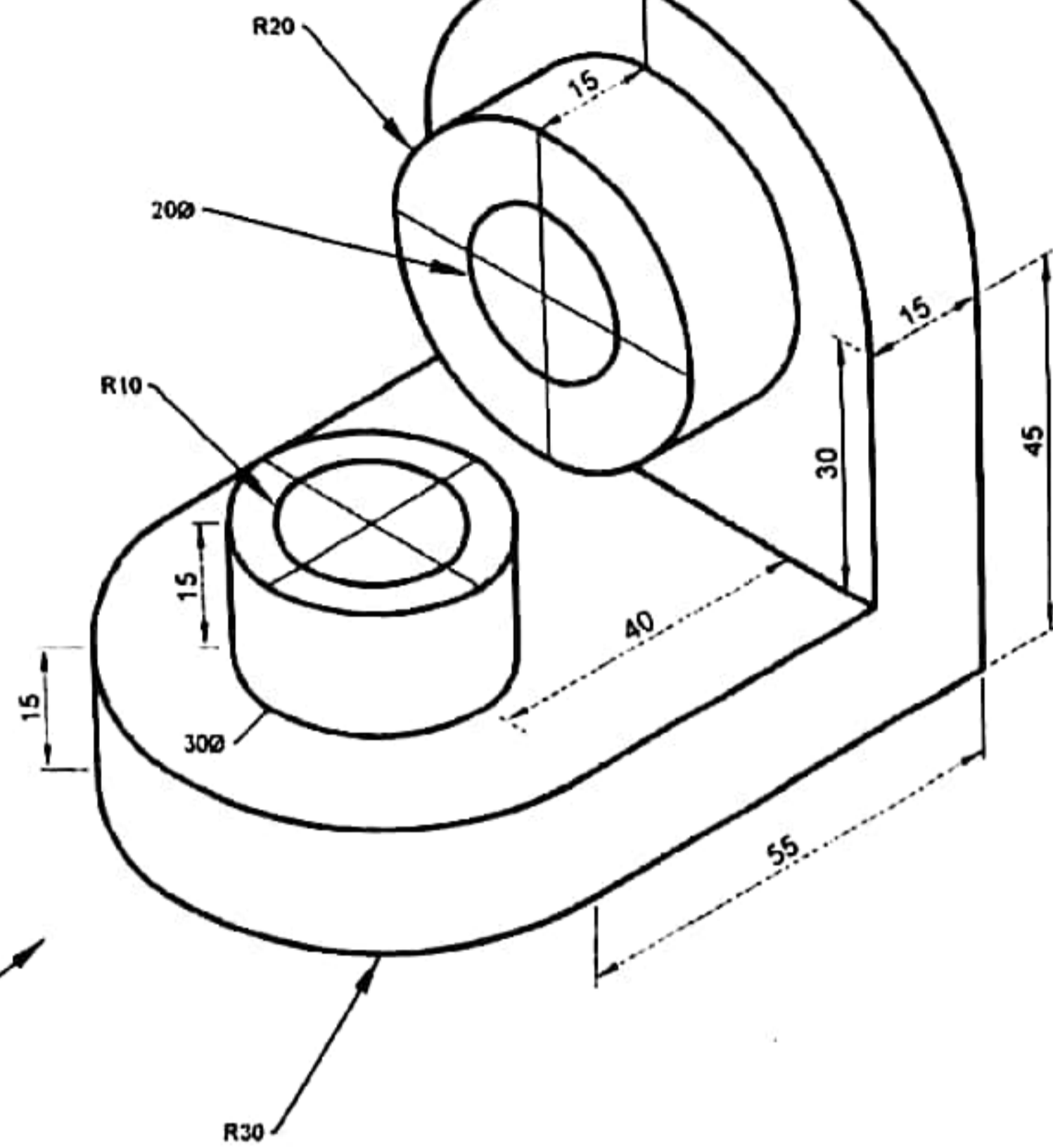

RIGHT SIDE VIEW

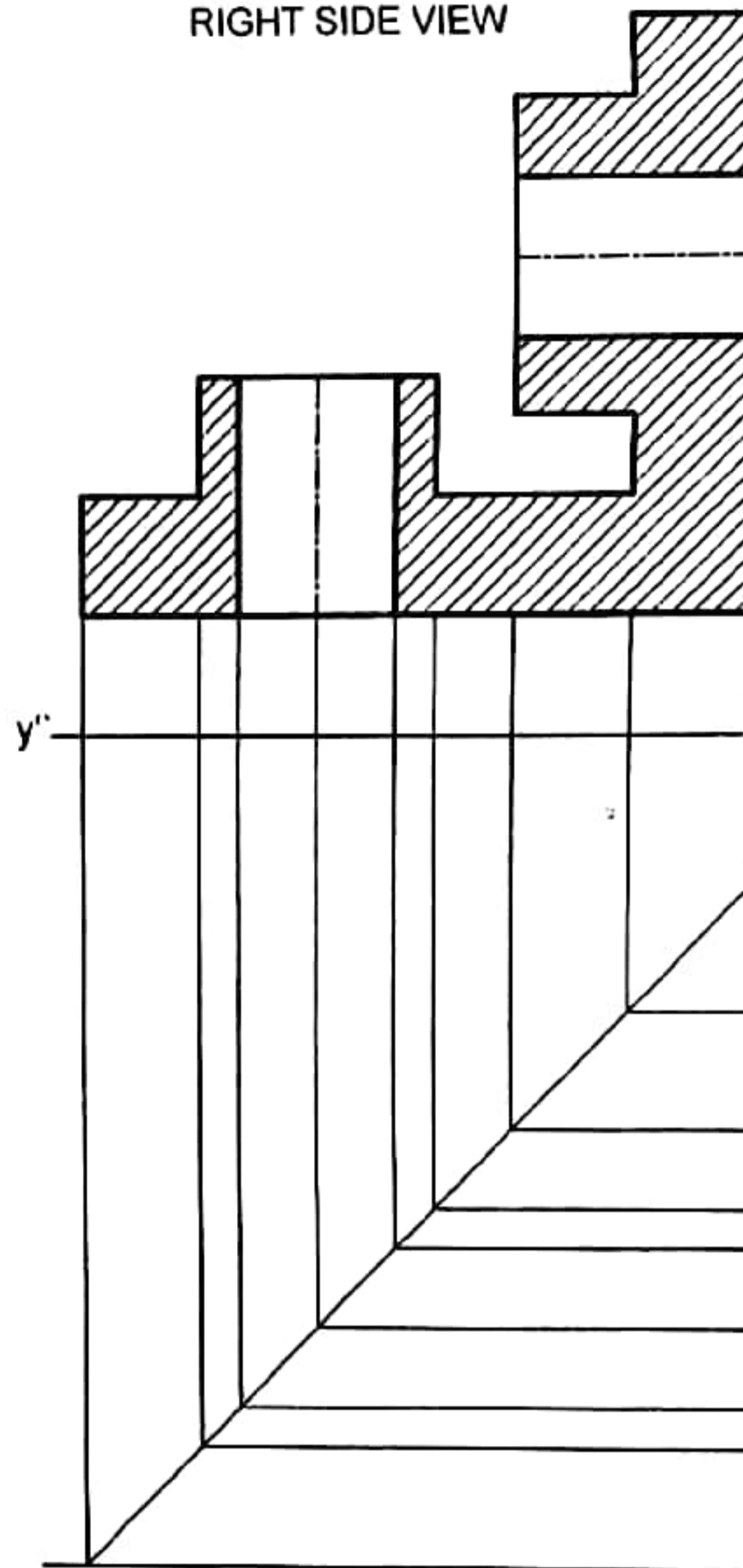

FRONT VIEW

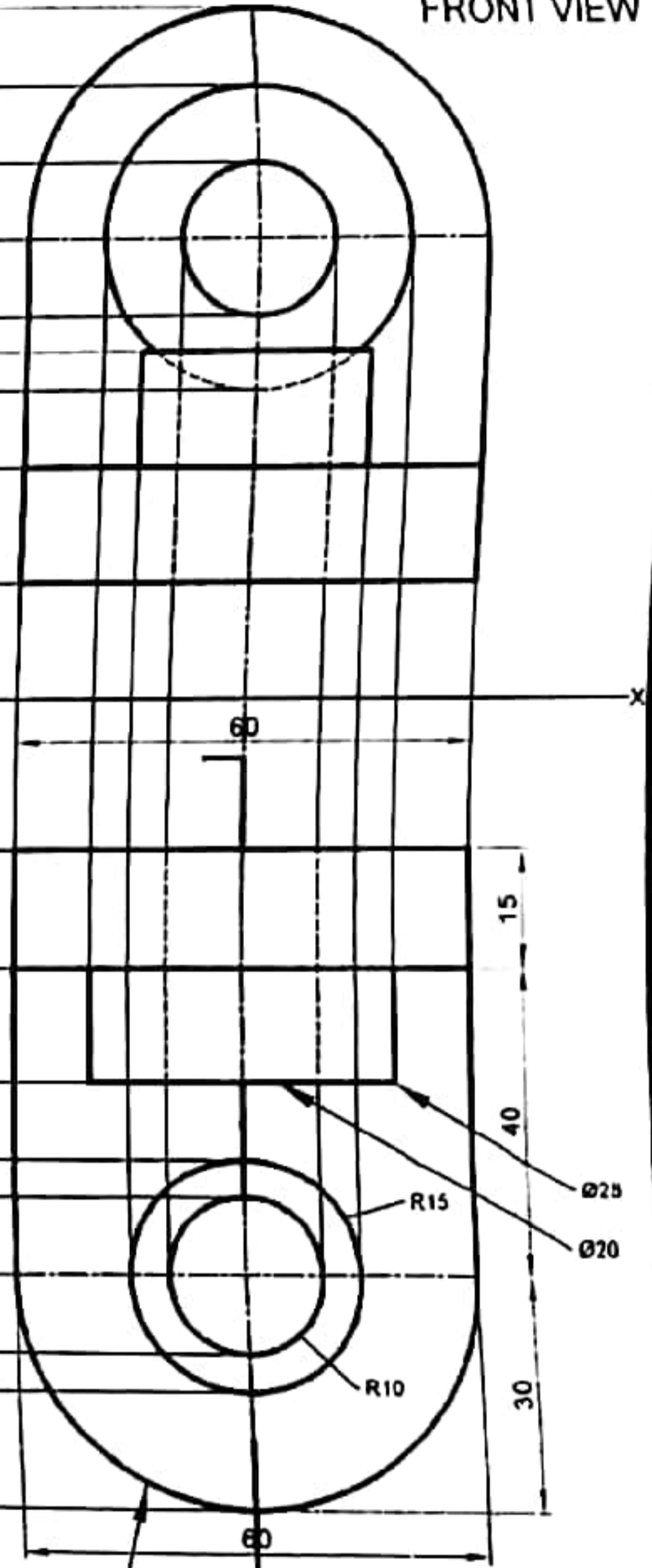

TOP VIEW

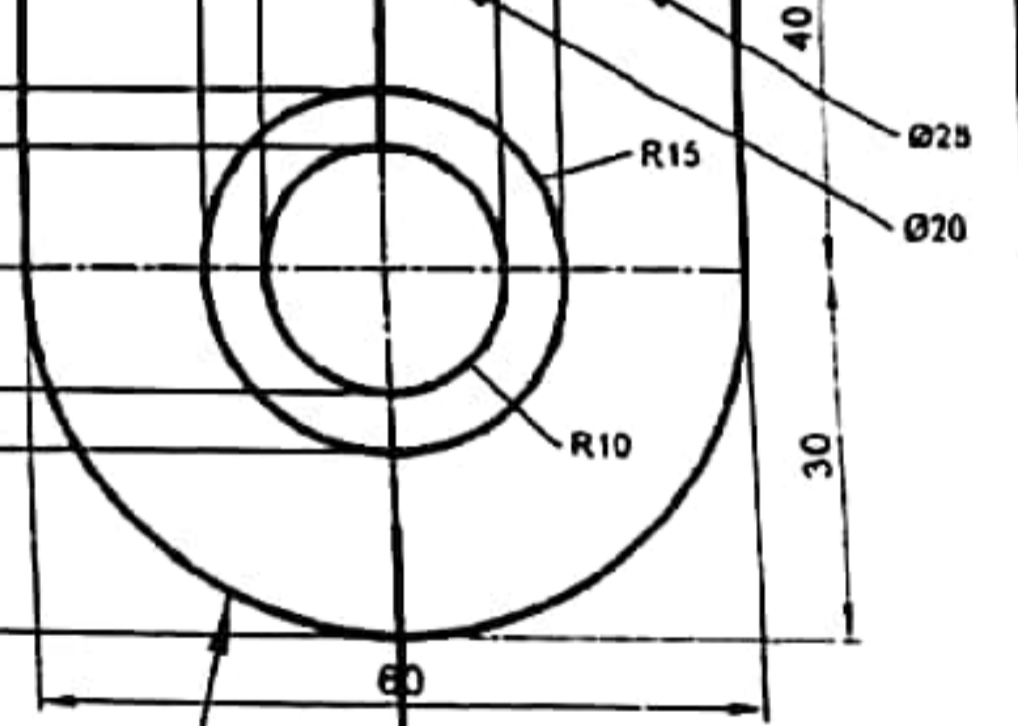

	SUBJECT	TITLE	DRAWN BY	CHECKED BY	DATE	SCALE
	ENGINEERING DRAWING		NAME			
			ROLL NO			
				DATE	DRAWING NO	44

TOP VIEW

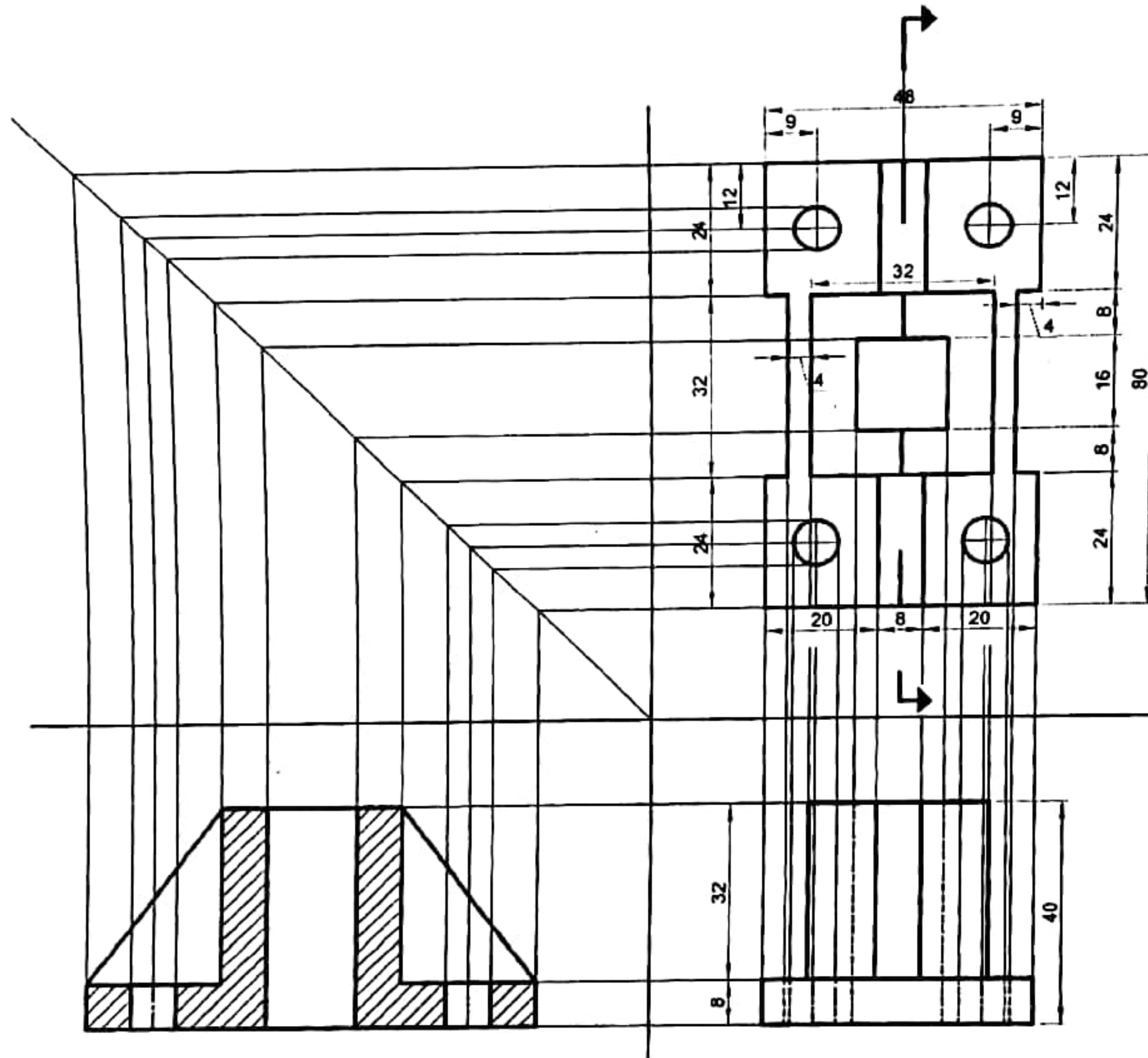

ISOMETRIC VIEW OF GIVEN SOLID

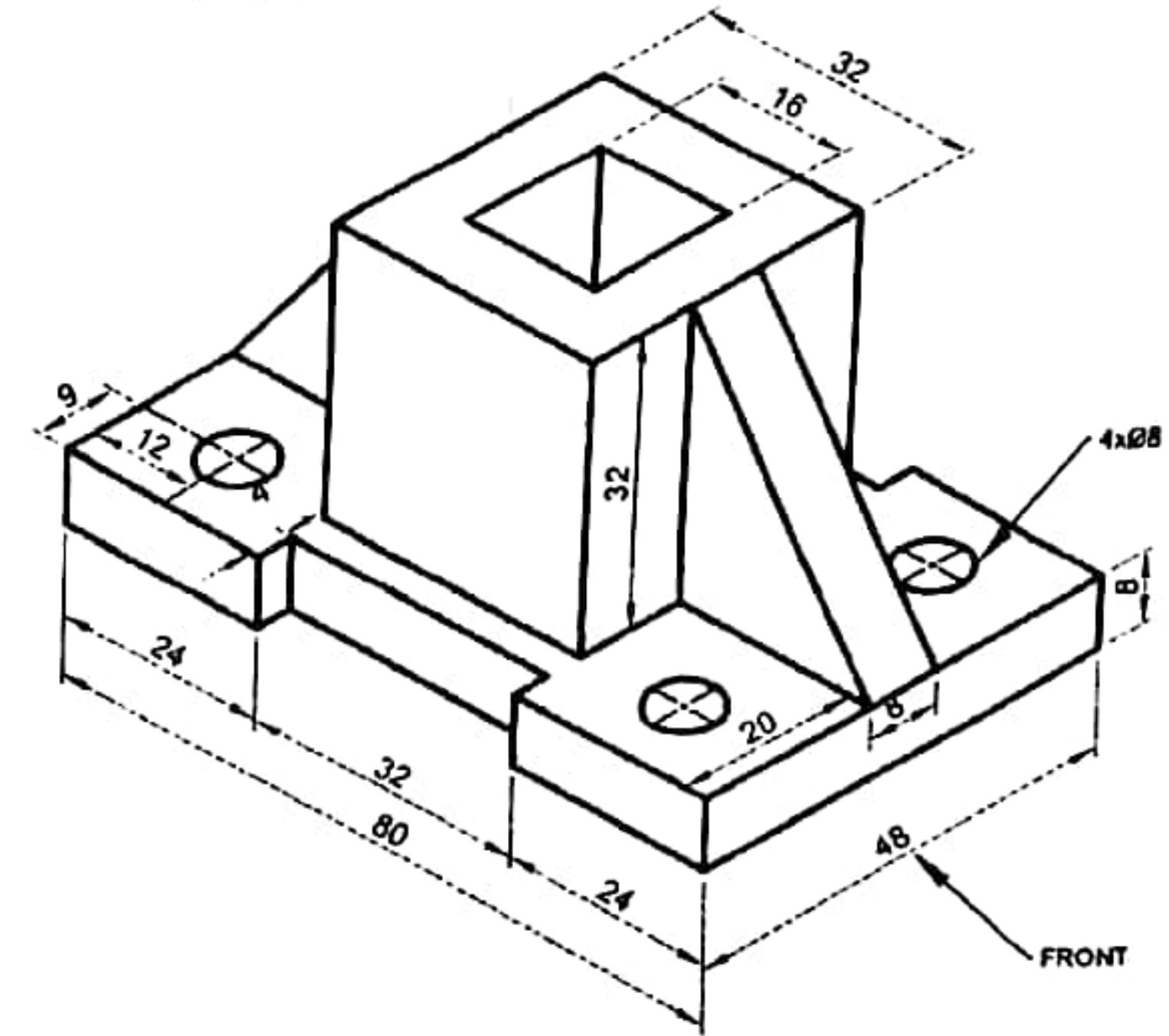

LEFT SIDE VIEW

FRONT VIEW

	SUBJECT	TITLE	DRAWN BY	CHECKED BY	DATE	SCALE
	ENGINEERING DRAWING		NAME ROLL NO			
				DATE	DRAWING NO 45	

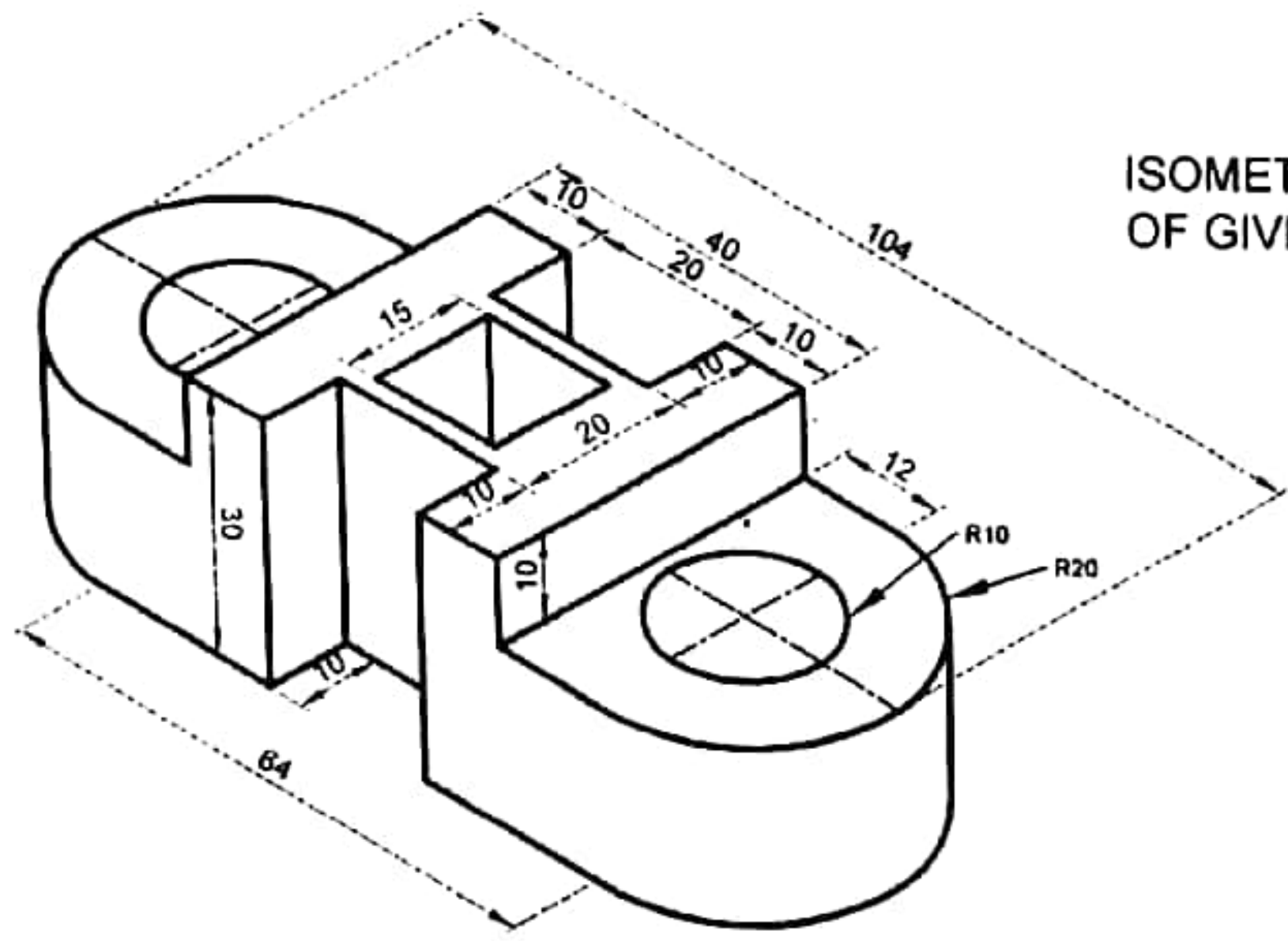

ISOMETRIC VIEW OF GIVEN SOLID

HALF SECTIONAL FRONT VIEW

LEFT SIDE SECTIONAL VIEW

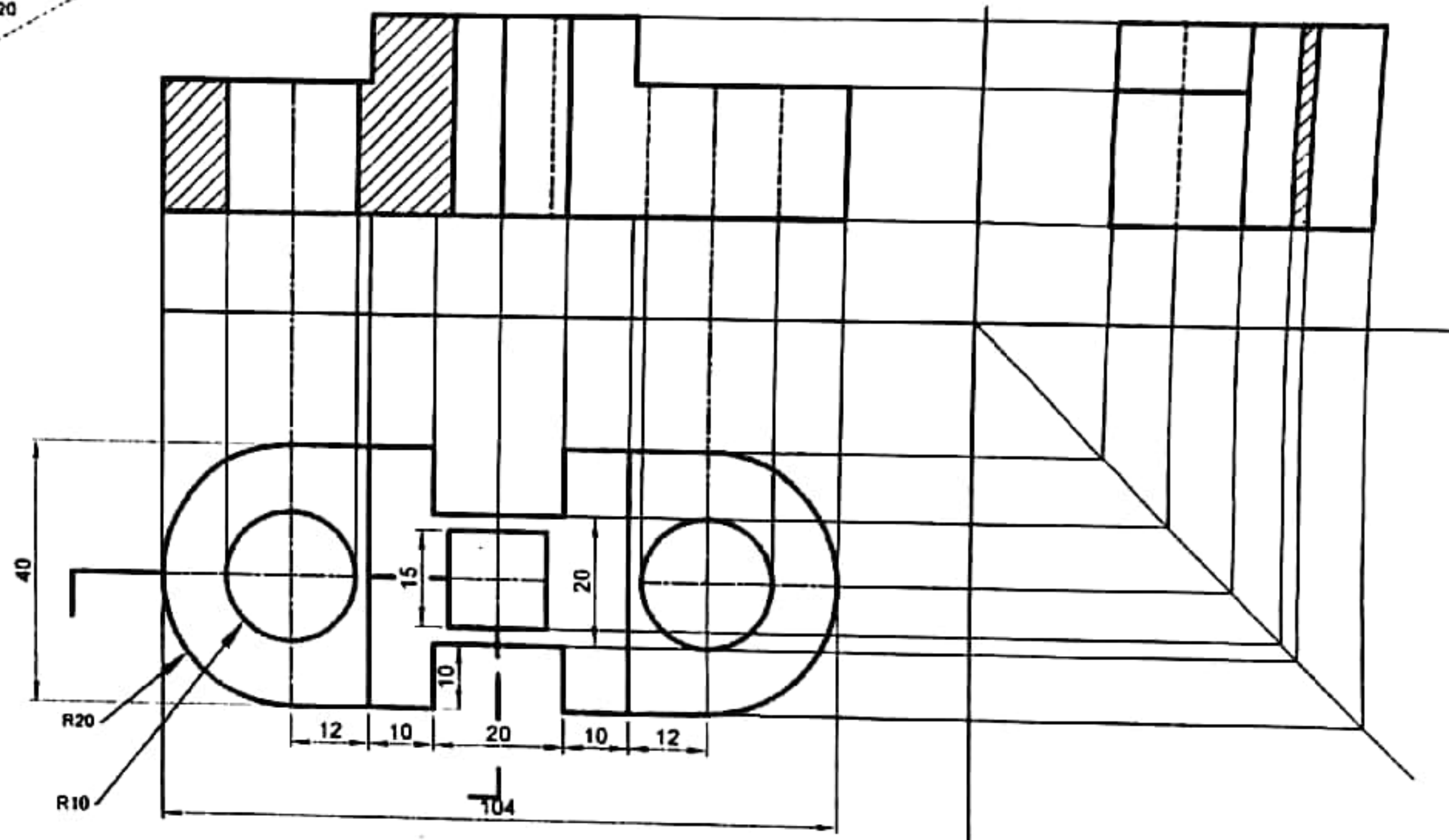

	SUBJECT	TITLE	DRAWN BY	CHECKED BY	DATE	SCALE
	ENGINEERING DRAWING					
			NAME			
			ROLL NO			
				DATE		
					DRAWING NO	46

ISOMETRIC VIEW
OF GIVEN SOLID

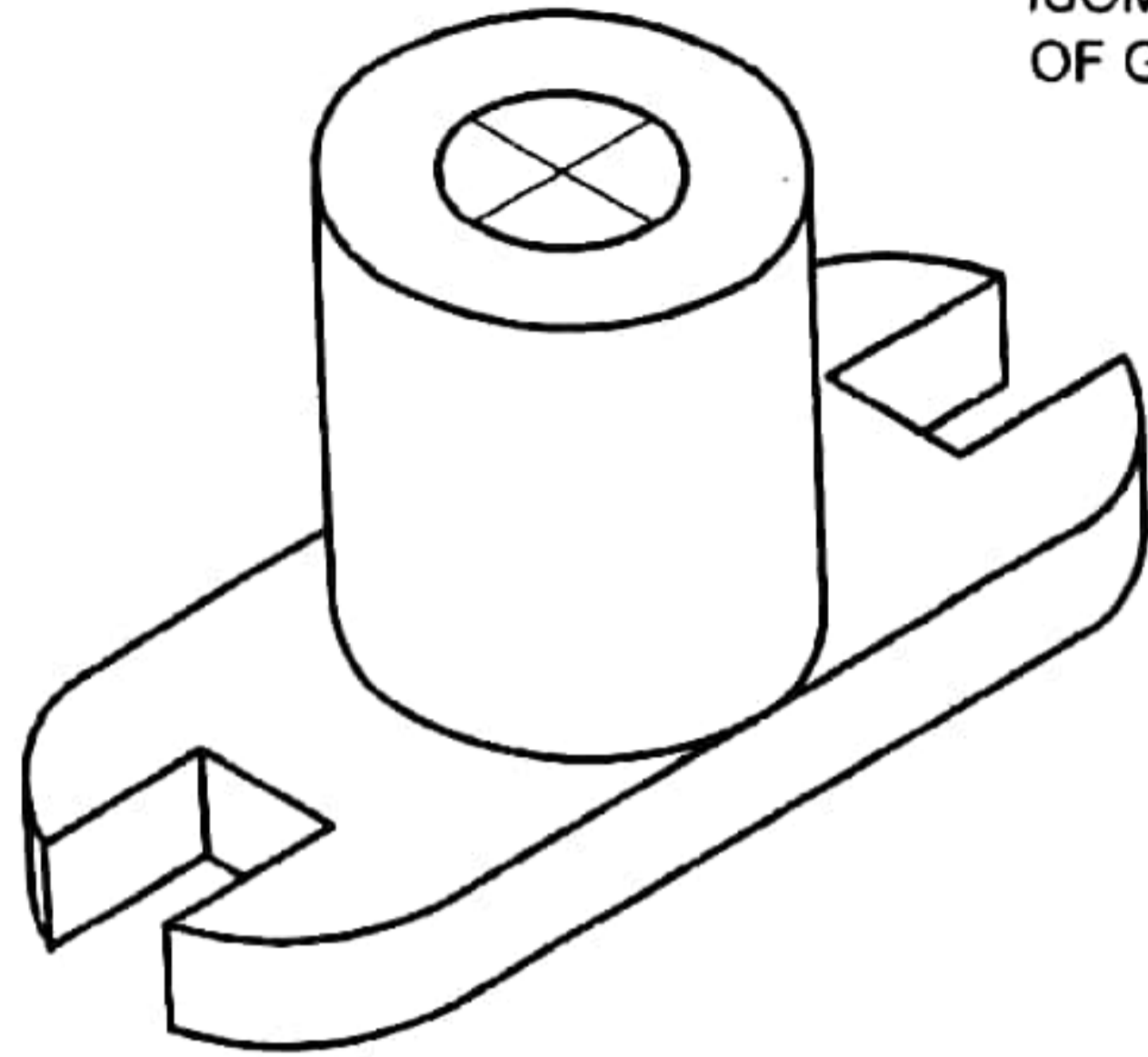

HALF SECTIONAL FRONT VIEW

LEFT SIDE VIEW

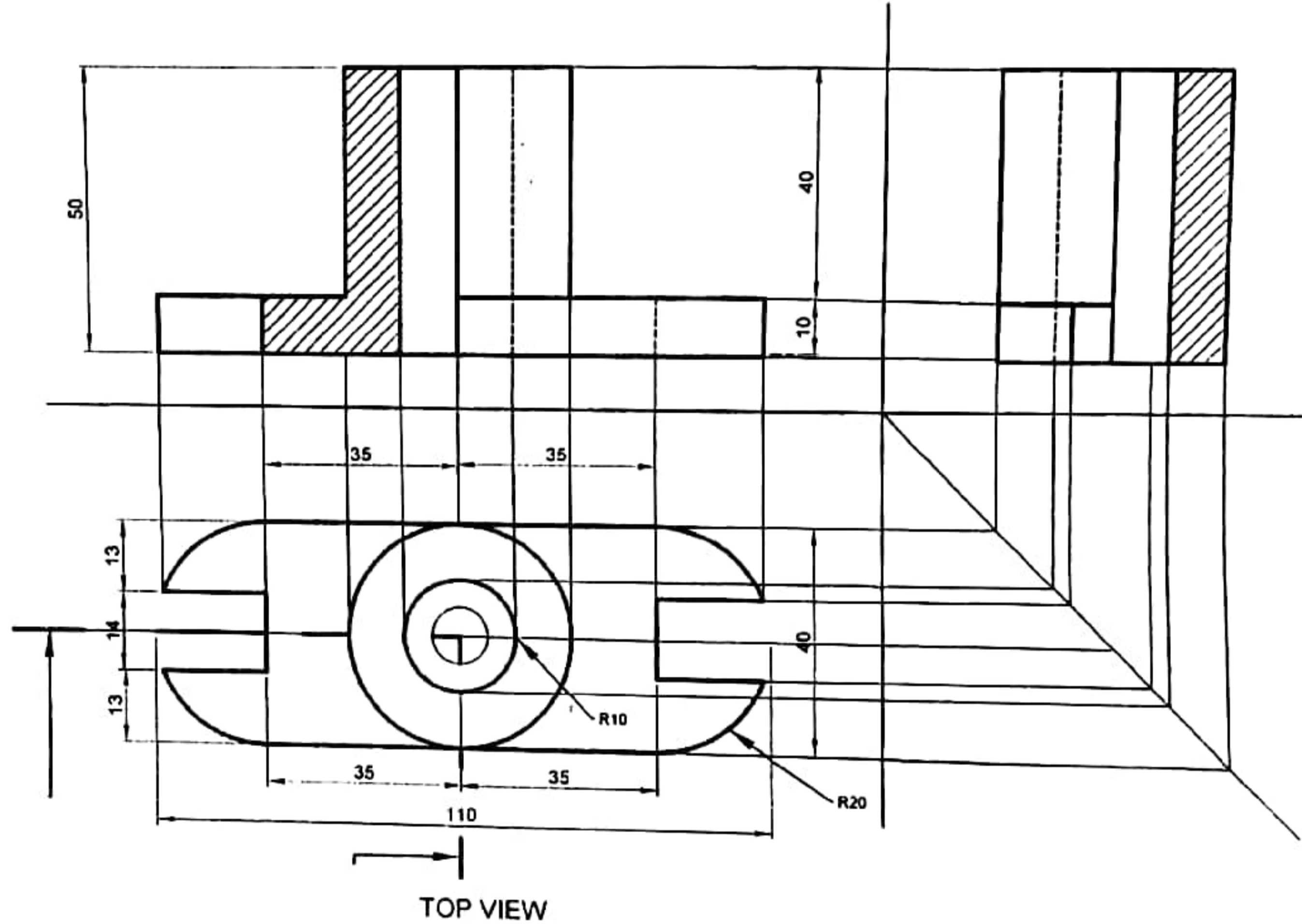

	SUBJECT	TITLE	DRAWN BY	CHECKED BY	DATE	SCALE
	ENGINEERING DRAWING	SECTION ORTHOGRAPHIC PROJECTION SHOWING THE FULL AND HALF SECTIONAL VIEW	NAME ROLL NO			
				DATE	DRAWING NO 47	

ISOMETRIC VIEW
OF GIVEN SOLIDS

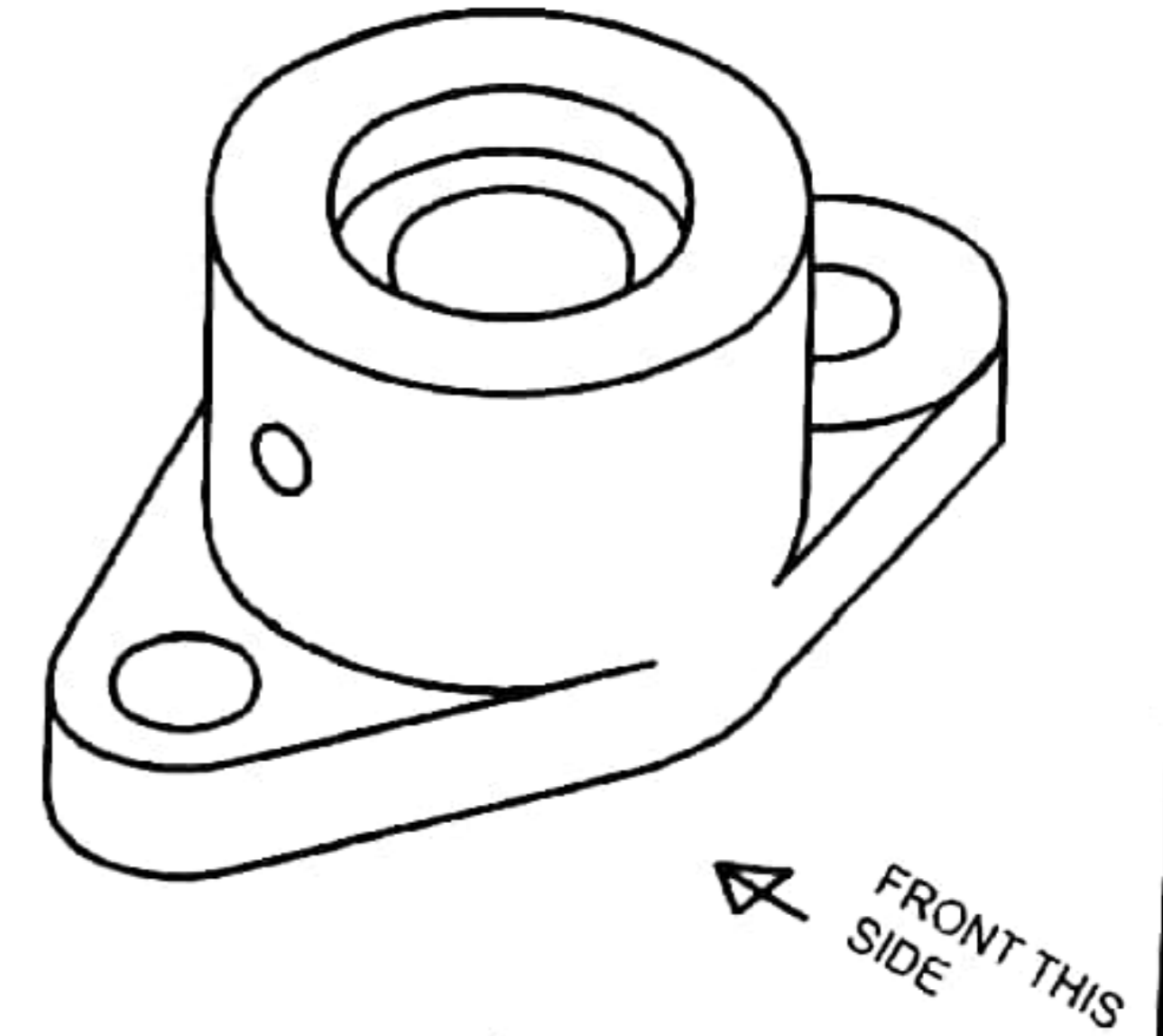

HALF SECTIONAL LEFT SIDE VIEW

HALF SECTIONAL FRONT VIEW

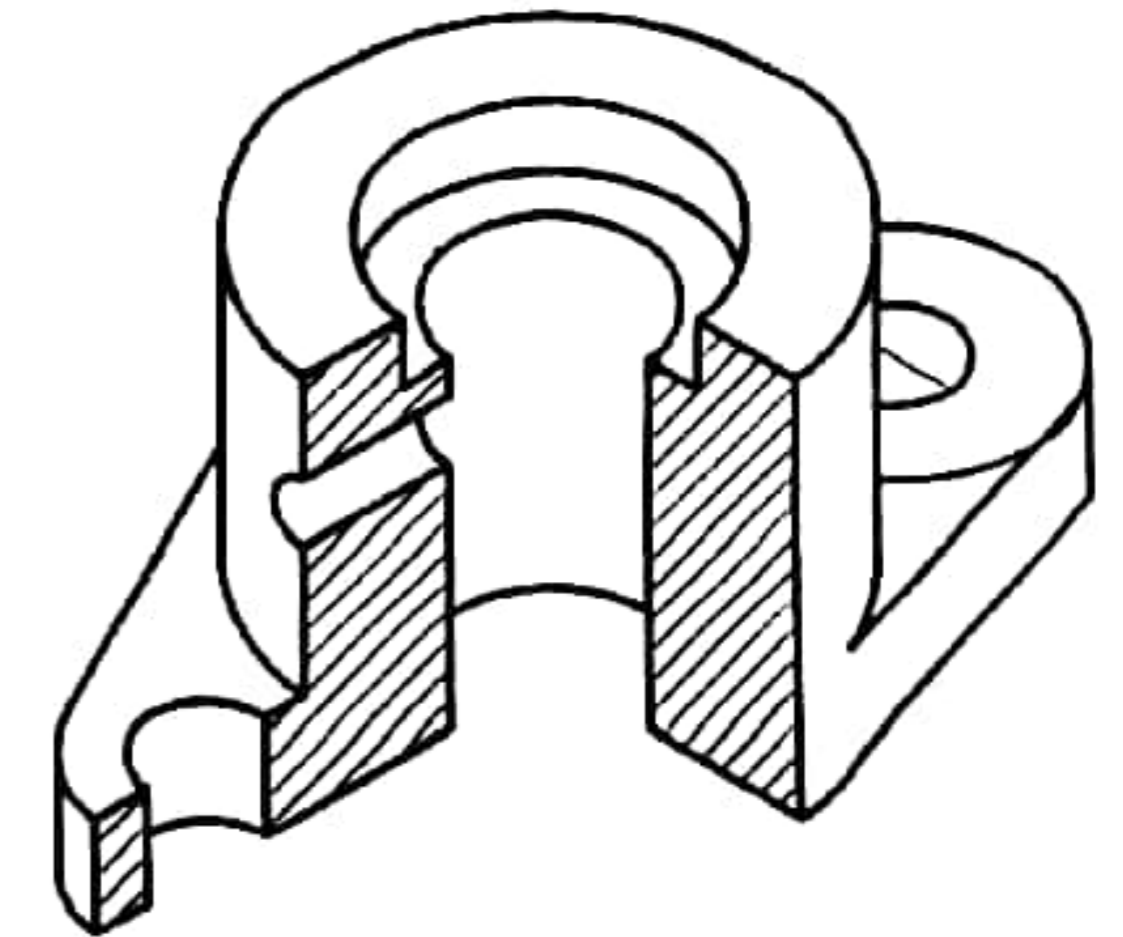
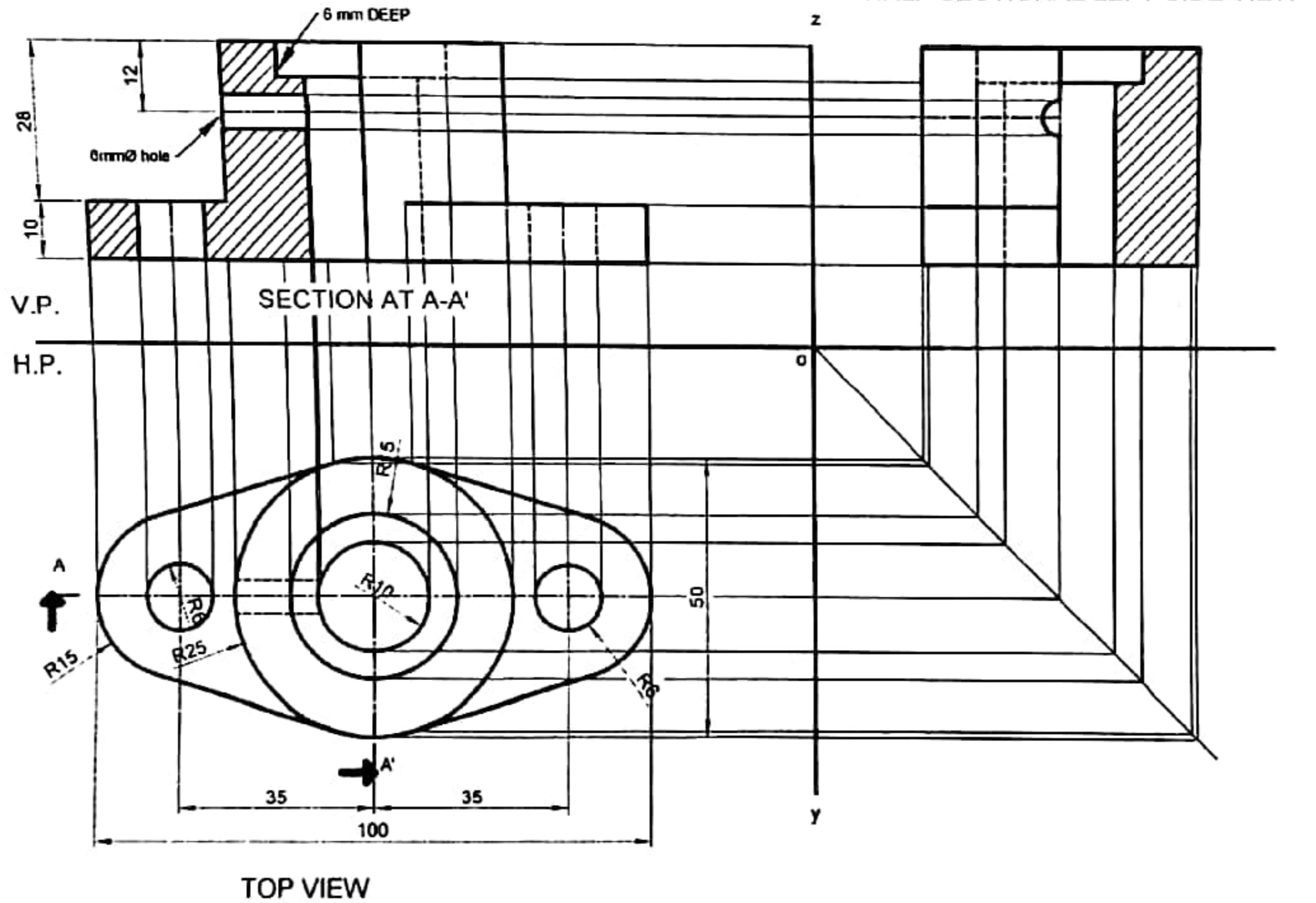

	SUBJECT	TITLE	DRAWN BY	CHECKED BY	DATE	SCALE
	ENGINEERING DRAWING	SECTION ORTHOGRAPHIC PROJECTION SHOWING THE FULL AND HALF SECTIONAL VIEW	NAME ROLL NO			
				DATE	DRAWING NO	48

ISOMETRIC VIEW
OF GIVEN SOLID

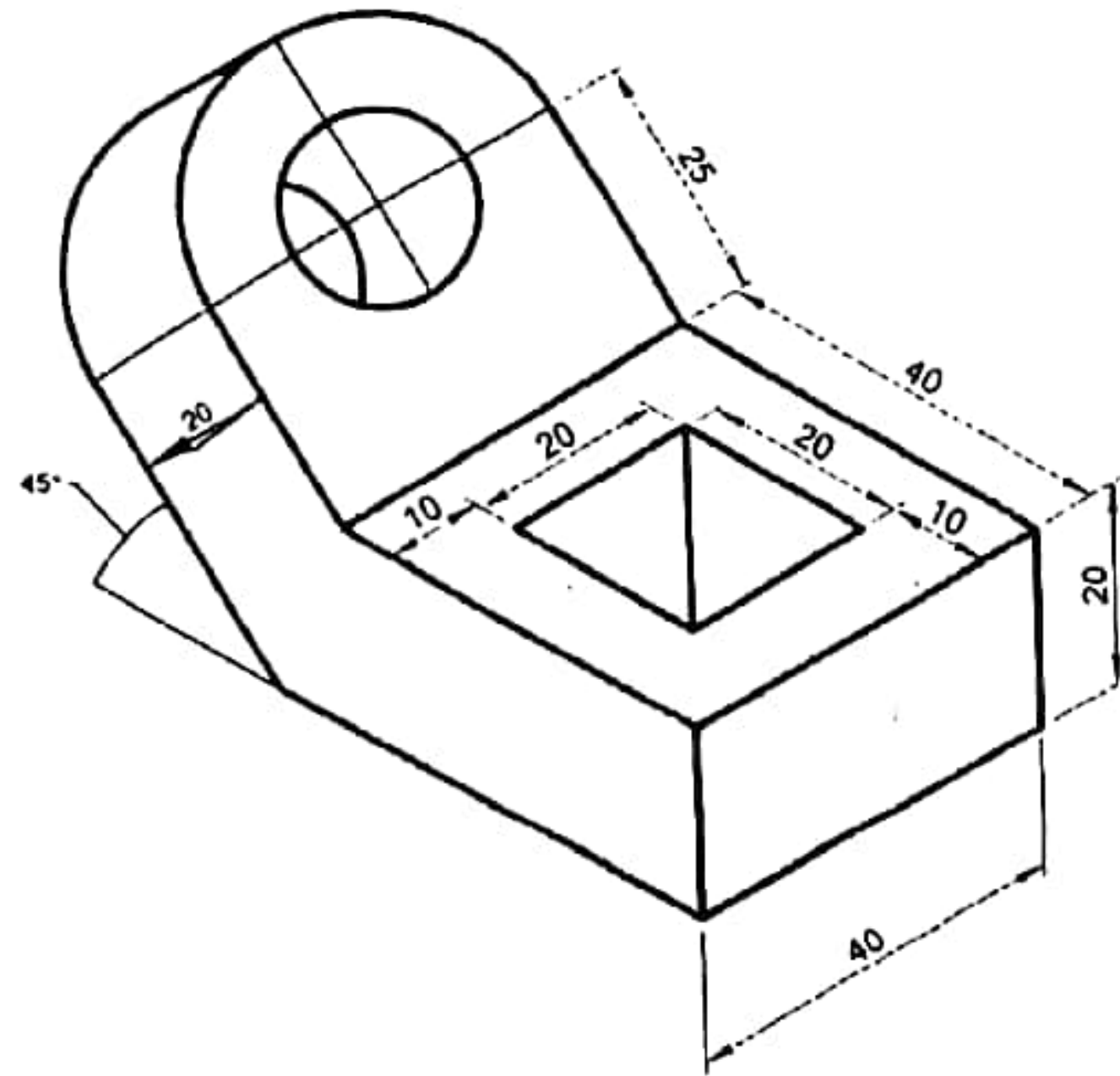

Right side view

Front View

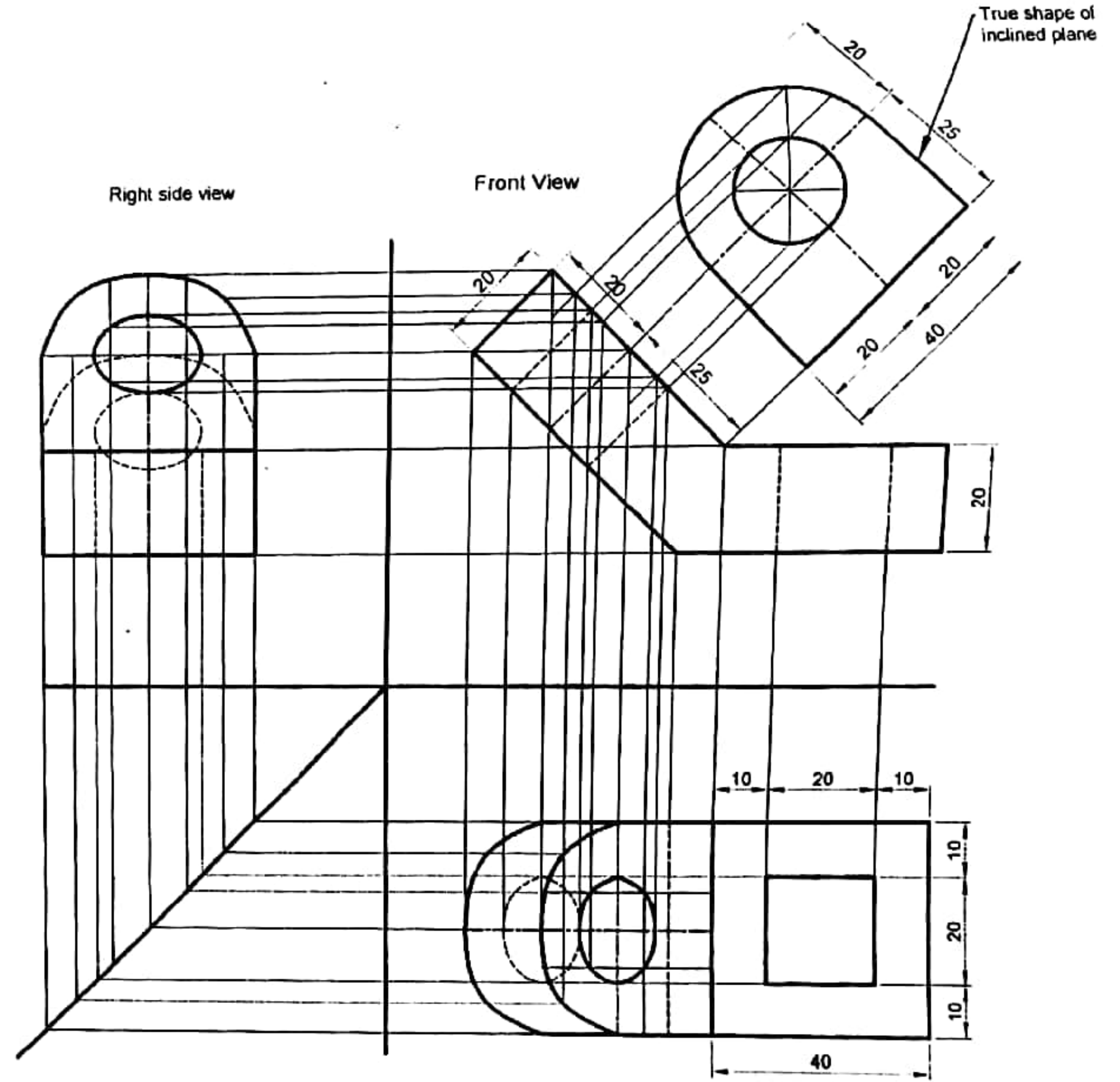

Top view

	SUBJECT	TITLE	DRAWN BY	CHECKED BY	DATE	SCALE
	ENGINEERING DRAWING	SECTION ORTHOGRAPHIC PROJECTION SHOWING THE AUXILIARY VIEW OF INCLINED PART (SURFACE)	NAME ROLL NO	DATE	DRAWING NO 49	

ISOMETRIC VIEW
OF GIVEN SOLID

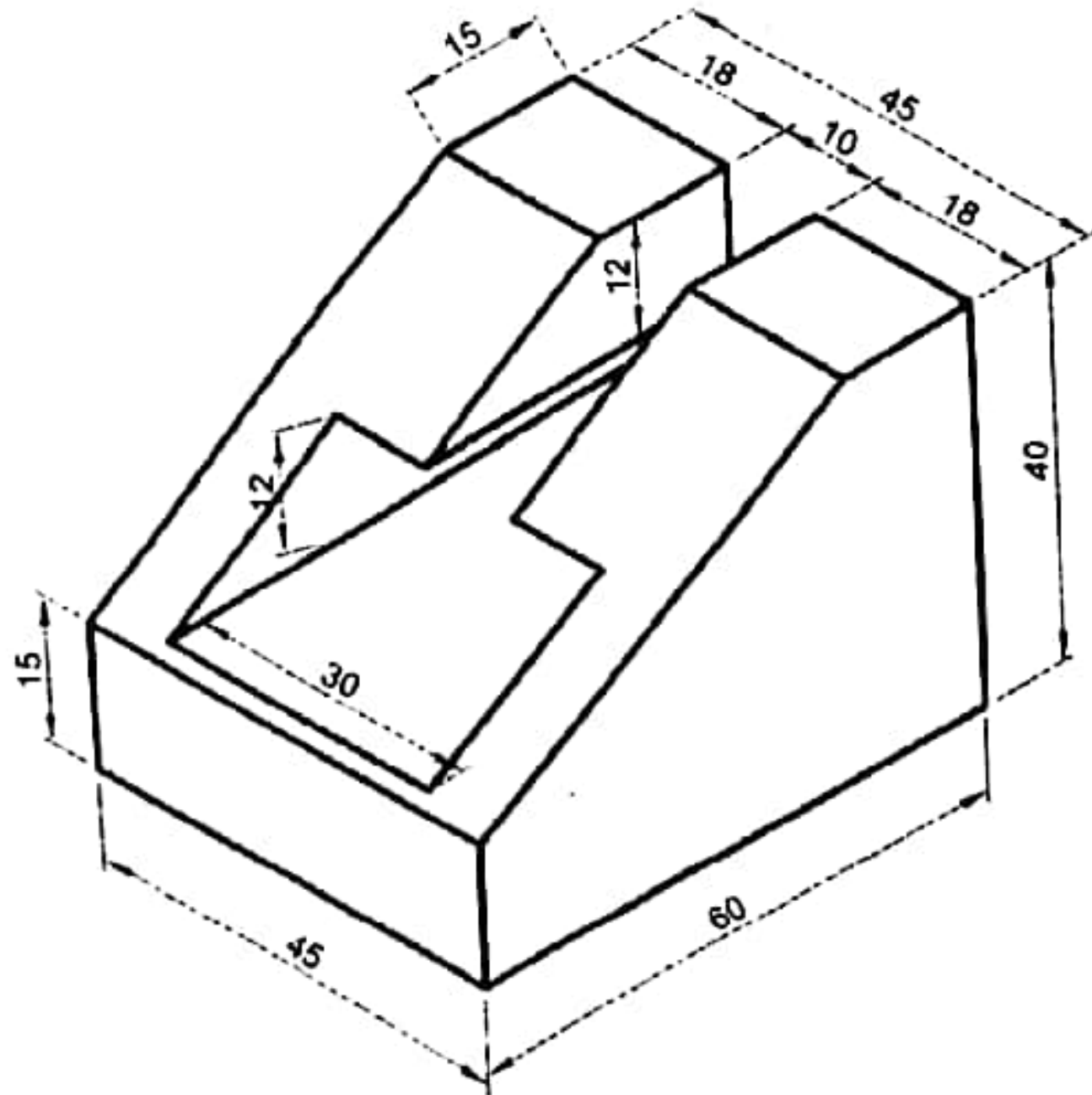

True shape
of inclined plane

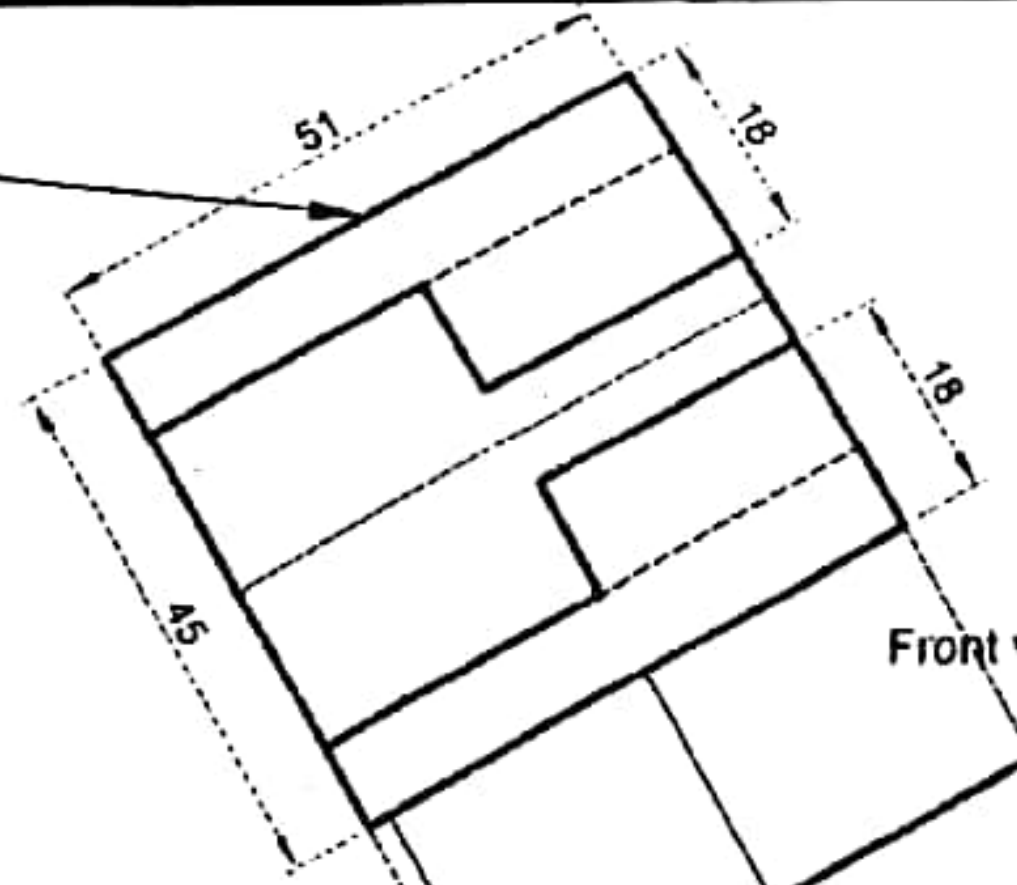

Front view

Left side view

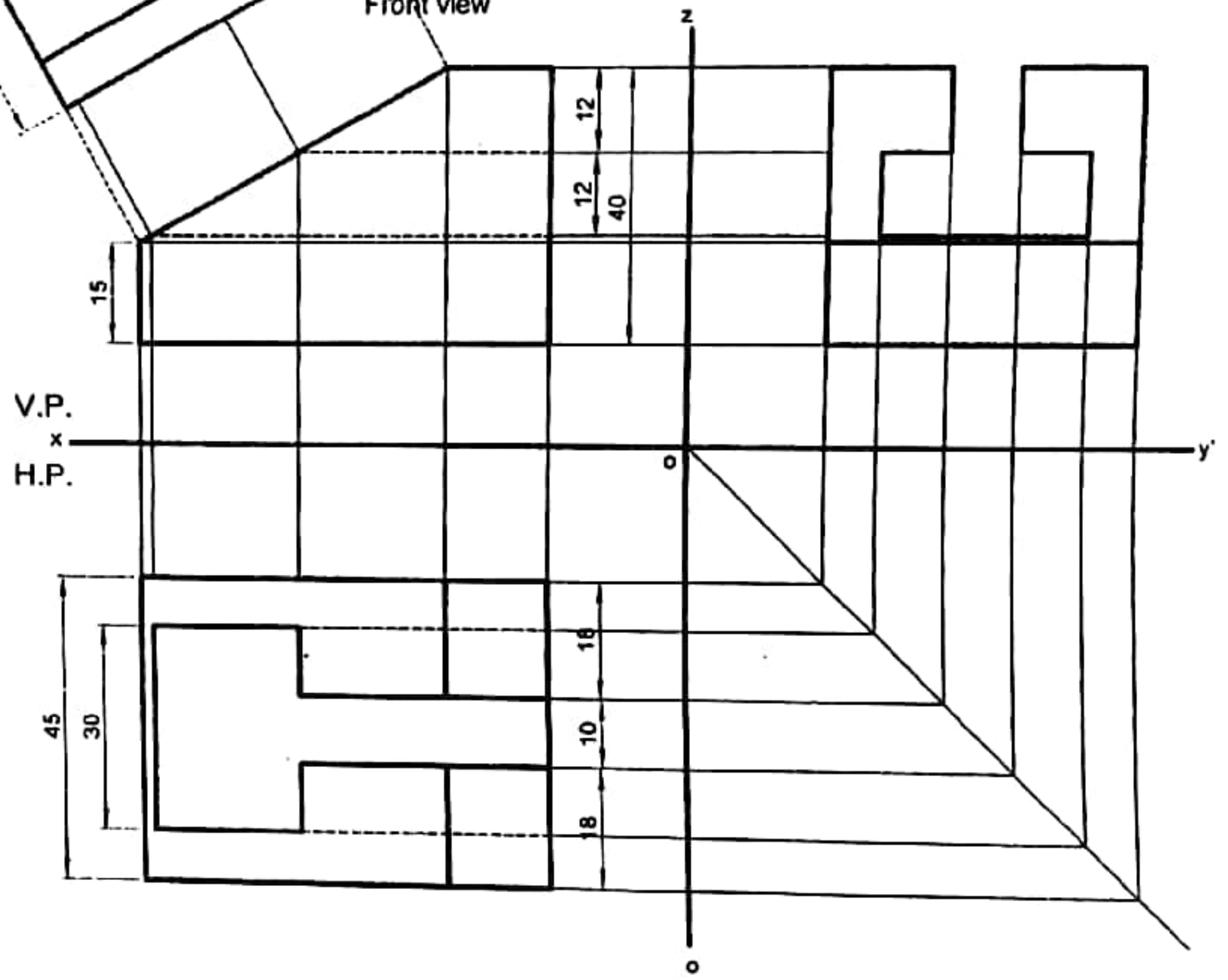

Top view

	SUBJECT	TITLE	DRAWN BY	CHECKED BY	DATE	SCALE
	ENGINEERING DRAWING	SECTION ORTHOGRAPHIC PROJECTION SHOWING THE FULL AND HALF SECTIONAL VIEW	NAME ROLL NO			
				DATE	DRAWING NO 50	

DRAW THE SECTIONAL FRONT AND SIDE VIEW OF GIVEN SOLID WHICH FIGURE IS GIVEN BELOW

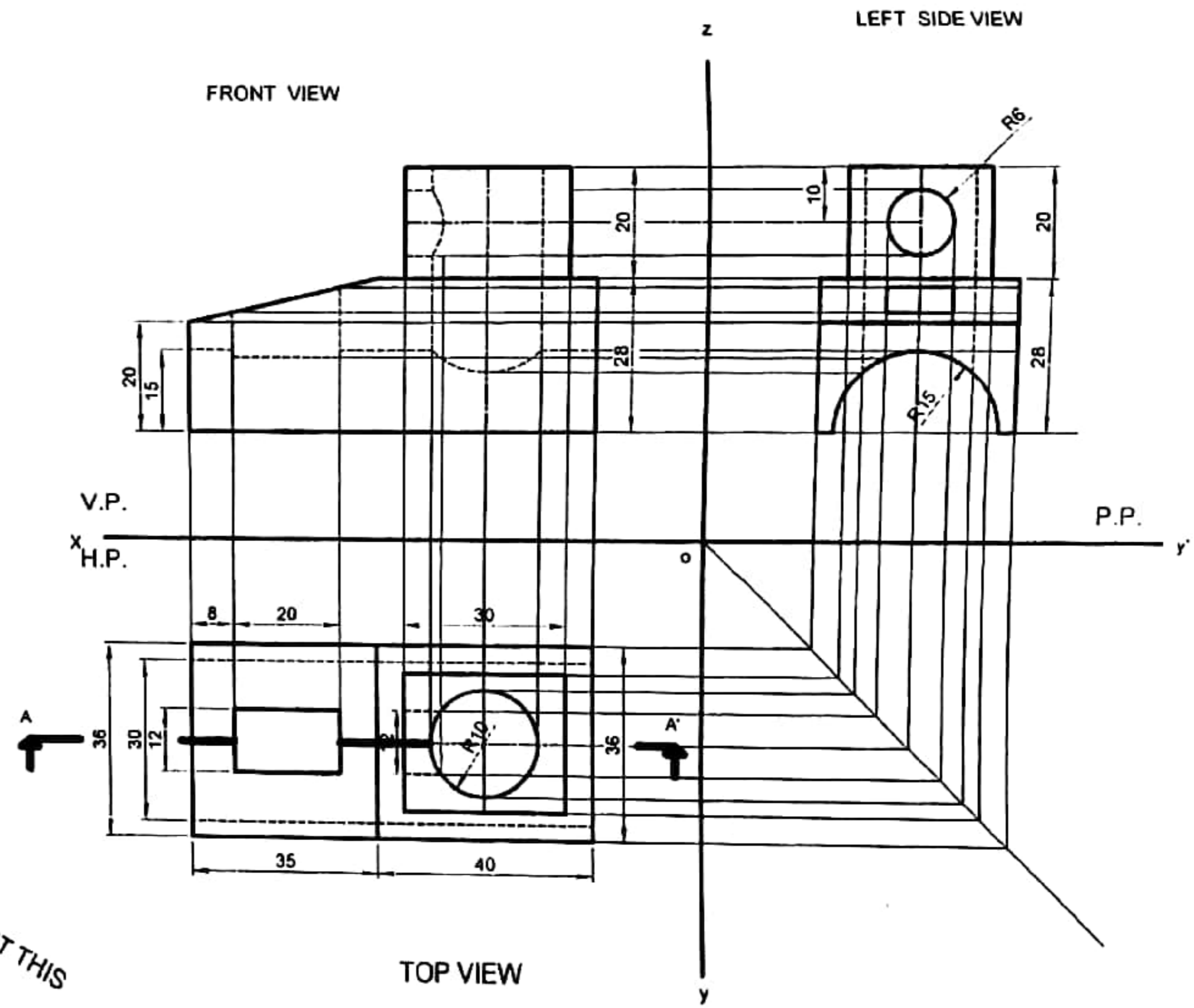
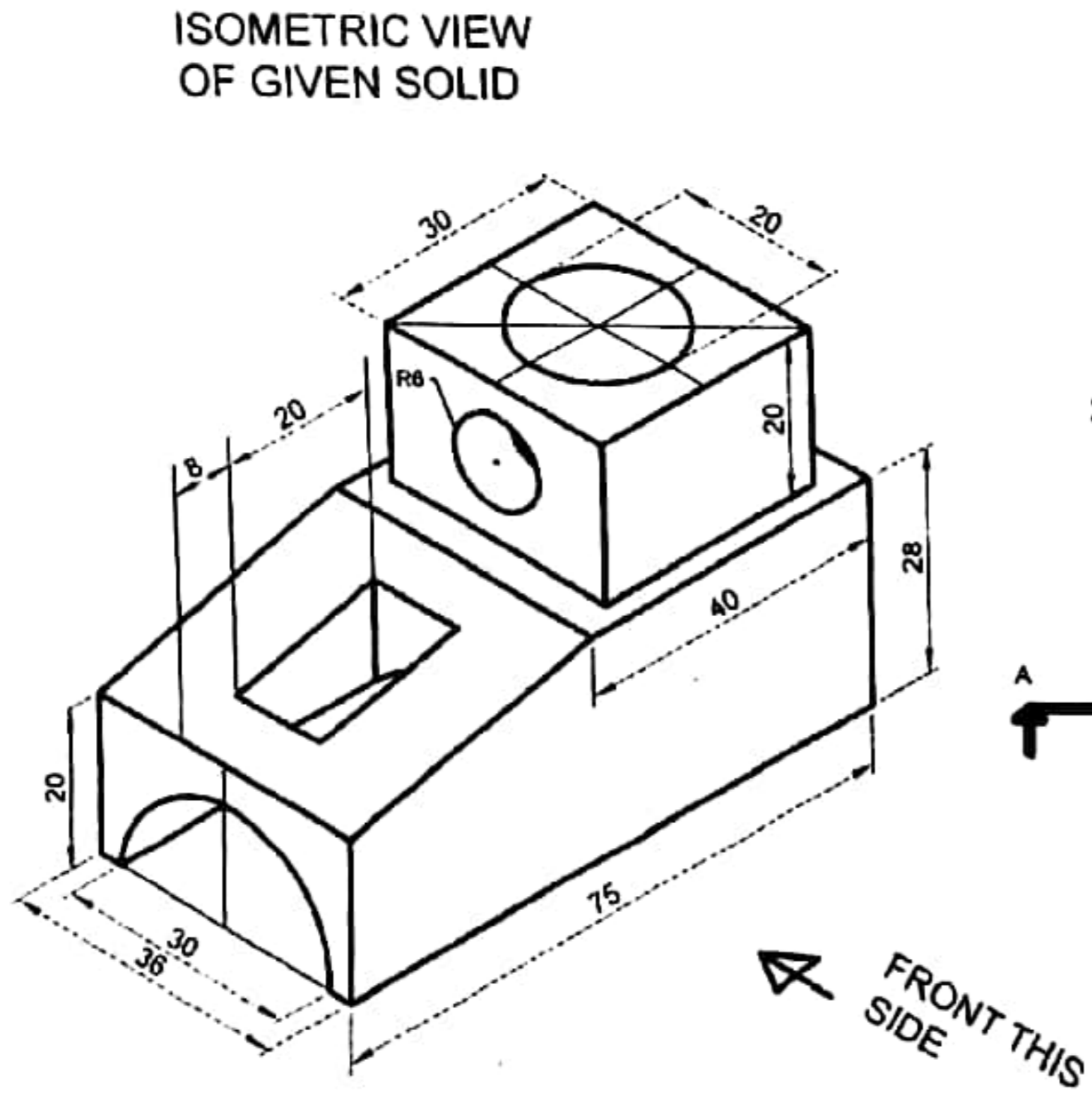

SUBJECT ENGINEERING DRAWING	TITLE SECTION ORTHOGRAPHIC PROJECTION SHOWING THE FULL AND HALF SECTIONAL VIEW	DRAWN BY NAME ROLL NO	CHECKED BY	DATE	SCALE
				DATE	DRAWING NO 51

DRAW THE FULL SECTIONAL FRONT AND SIDE VIEW OF GIVEN SOLID WHICH FIGURE IS GIVEN BELOW

ISOMETRIC VIEW OF GIVEN SOLID

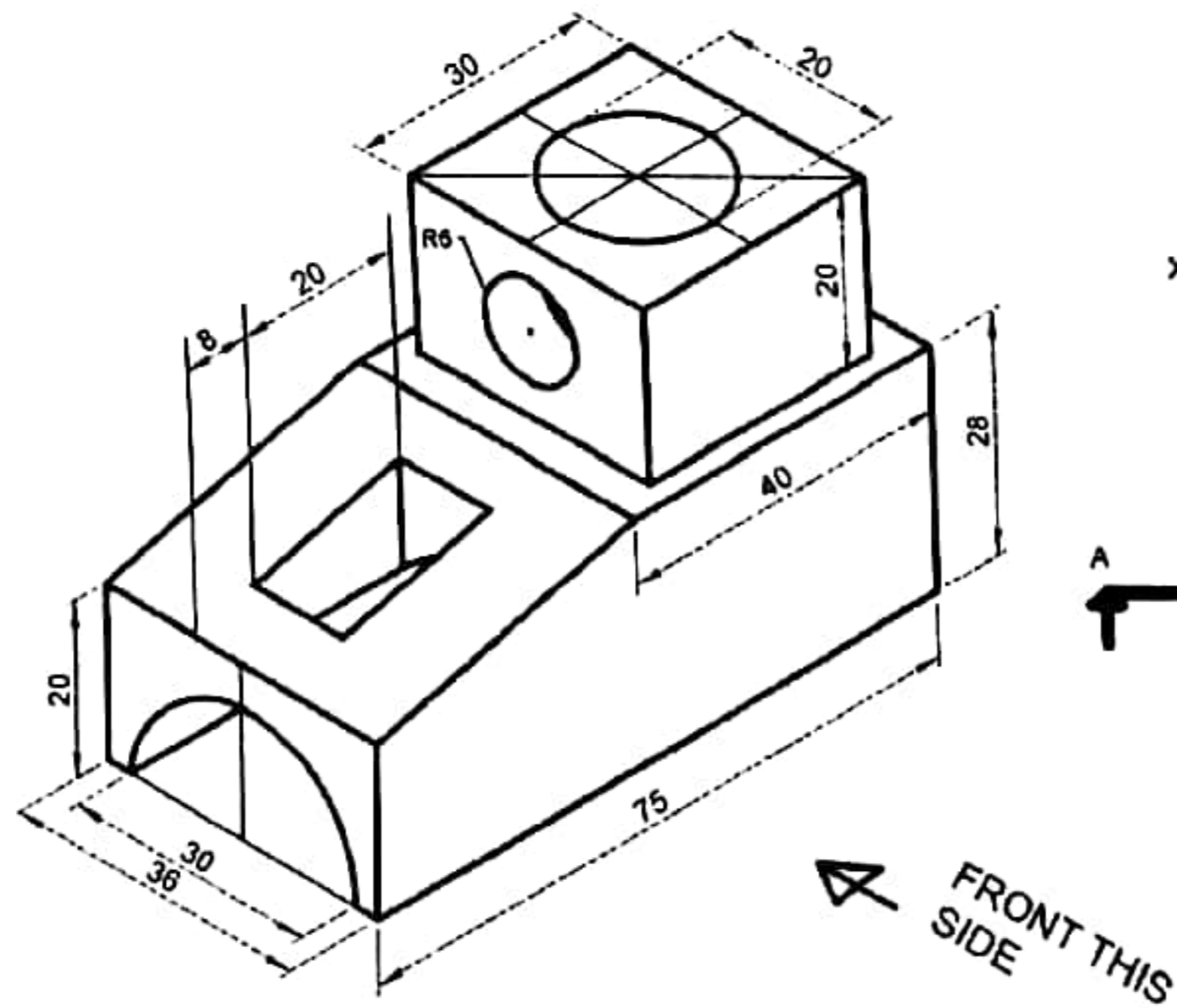

FULL SECTIONAL FRONT VIEW

RIGHT SIDE VIEW
LEFT SIDE VIEW

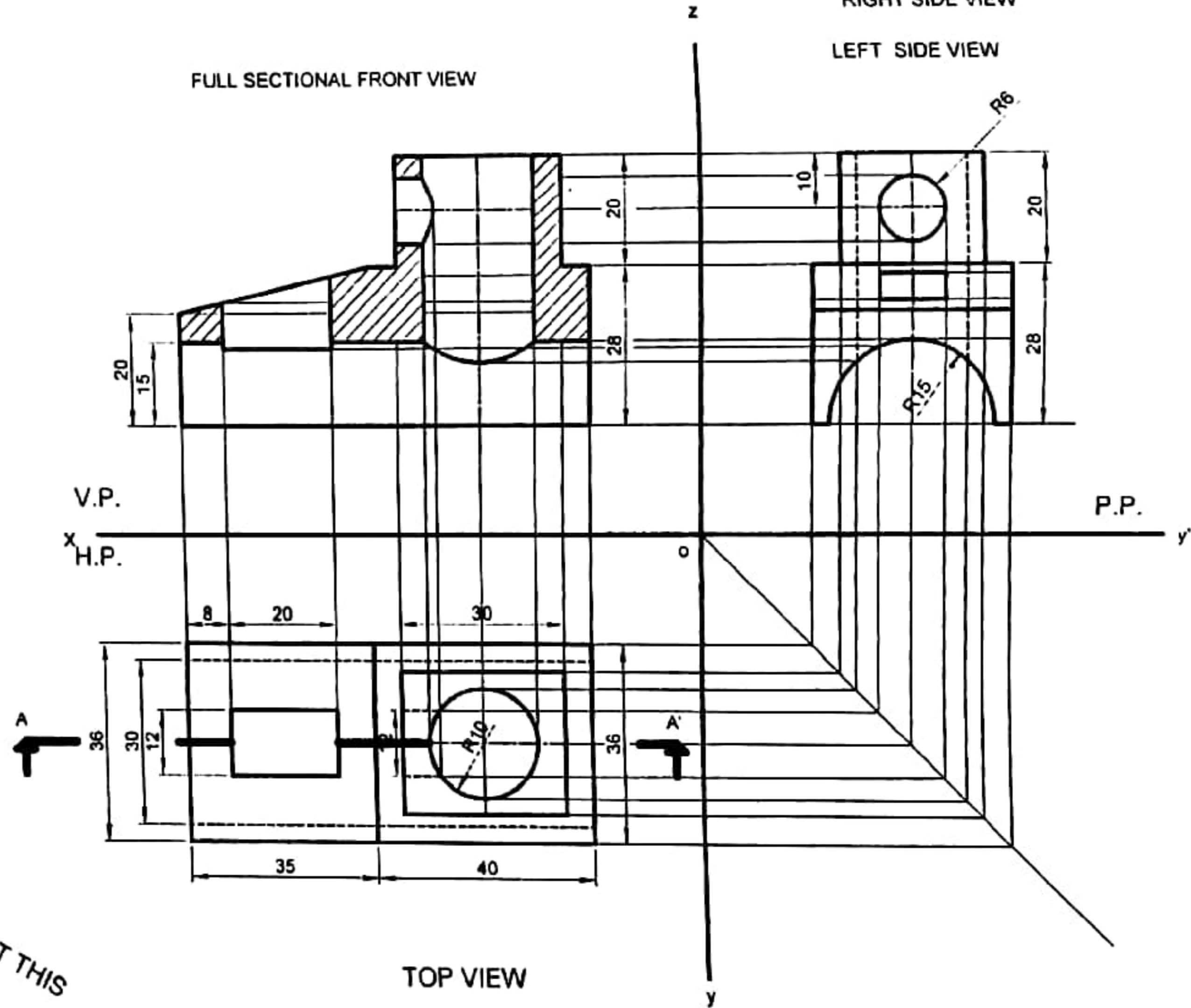

TOP VIEW

SUBJECT ENGINEERING DRAWING	TITLE SECTION ORTHOGRAPHIC PROJECTION SHOWING THE FULL AND HALF SECTIONAL VIEW	DRAWN BY NAME ROLL NO	CHECKED BY DATE	DATE	SCALE
				DRAWING NO 52	

ISOMETRIC VIEW
OF GIVEN SOLID

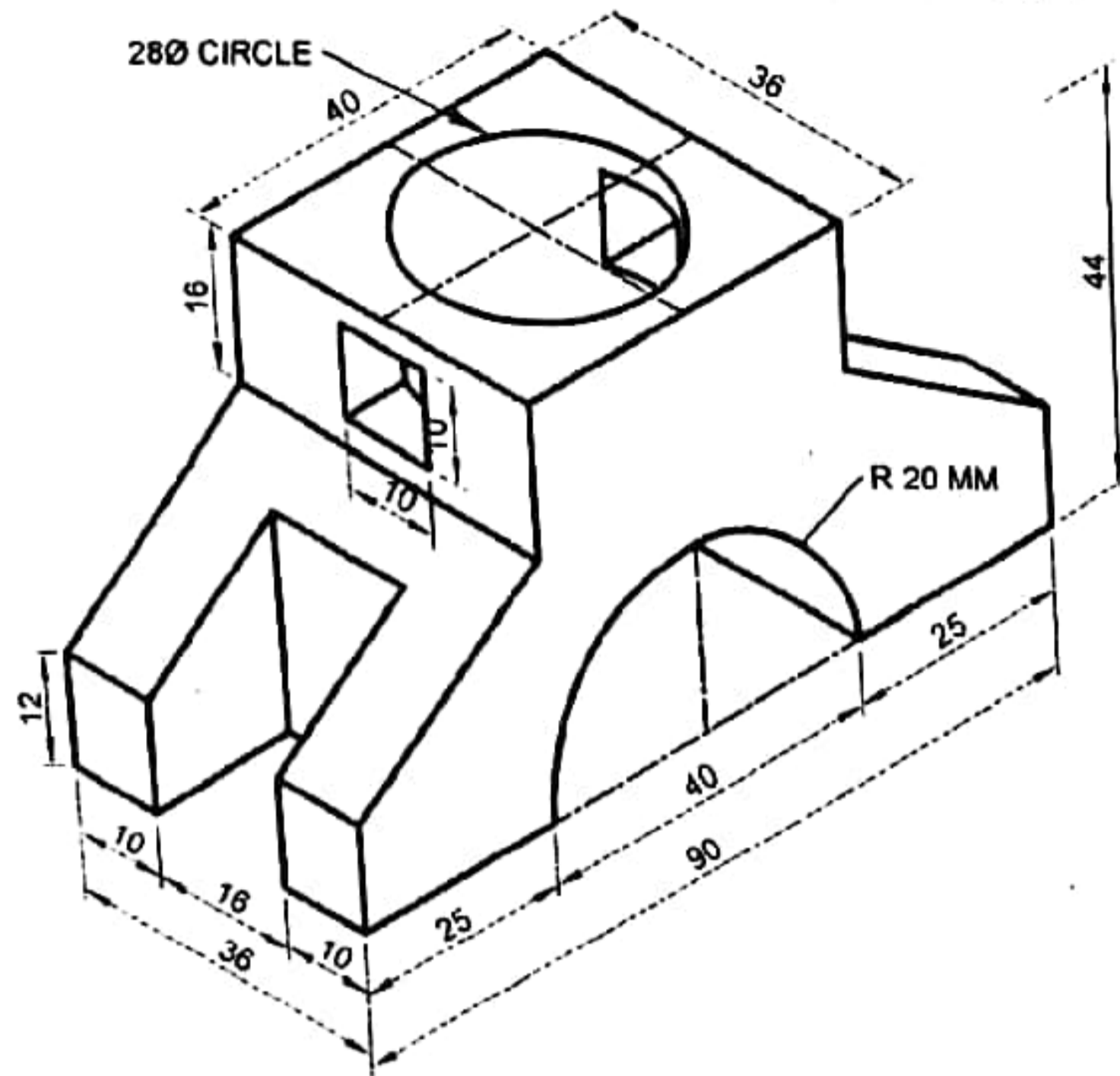

DRAW THE SECTIONAL FRONT AND SIDE VIEW OF
GIVEN SOLID WHICH FIGURE IS GIVEN ABOVE

FULL SECTIONAL FRONT VIEW

LEFT SIDE VIEW

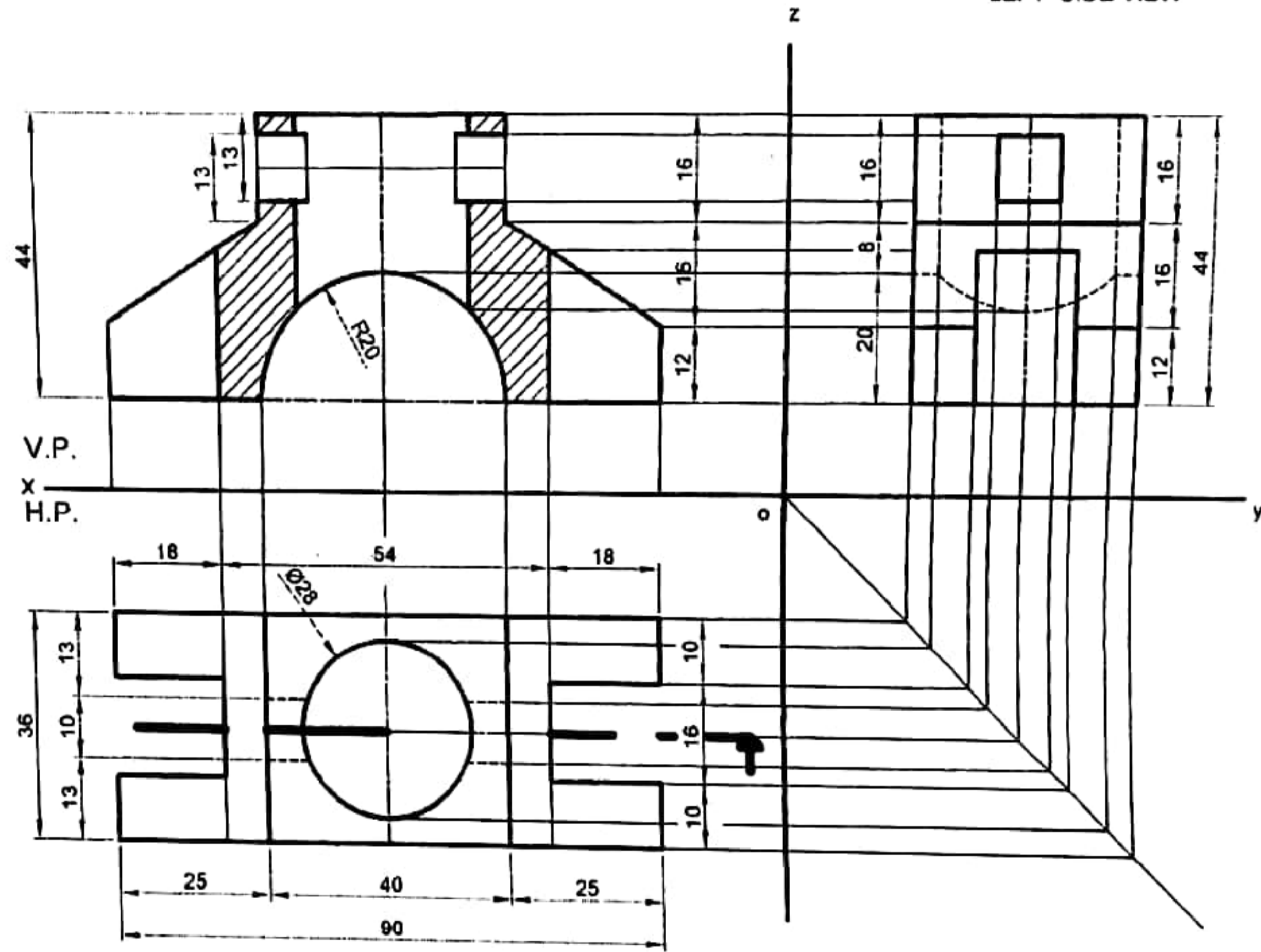

TOP VIEW

SUBJECT ENGINEERING DRAWING	TITLE SECTION ORTHOGRAPHIC PROJECTION SHOWING THE FULL AND HALF SECTIONAL VIEW	DRAWN BY NAME ROLL NO	CHECKED BY DATE	DATE	SCALE
				DRAWING NO 53	

DRAW THE FULL SECTIONAL FRONT AND SIDE VIEW OF GIVEN SOLID WHICH FIGURE IS GIVEN BELOW

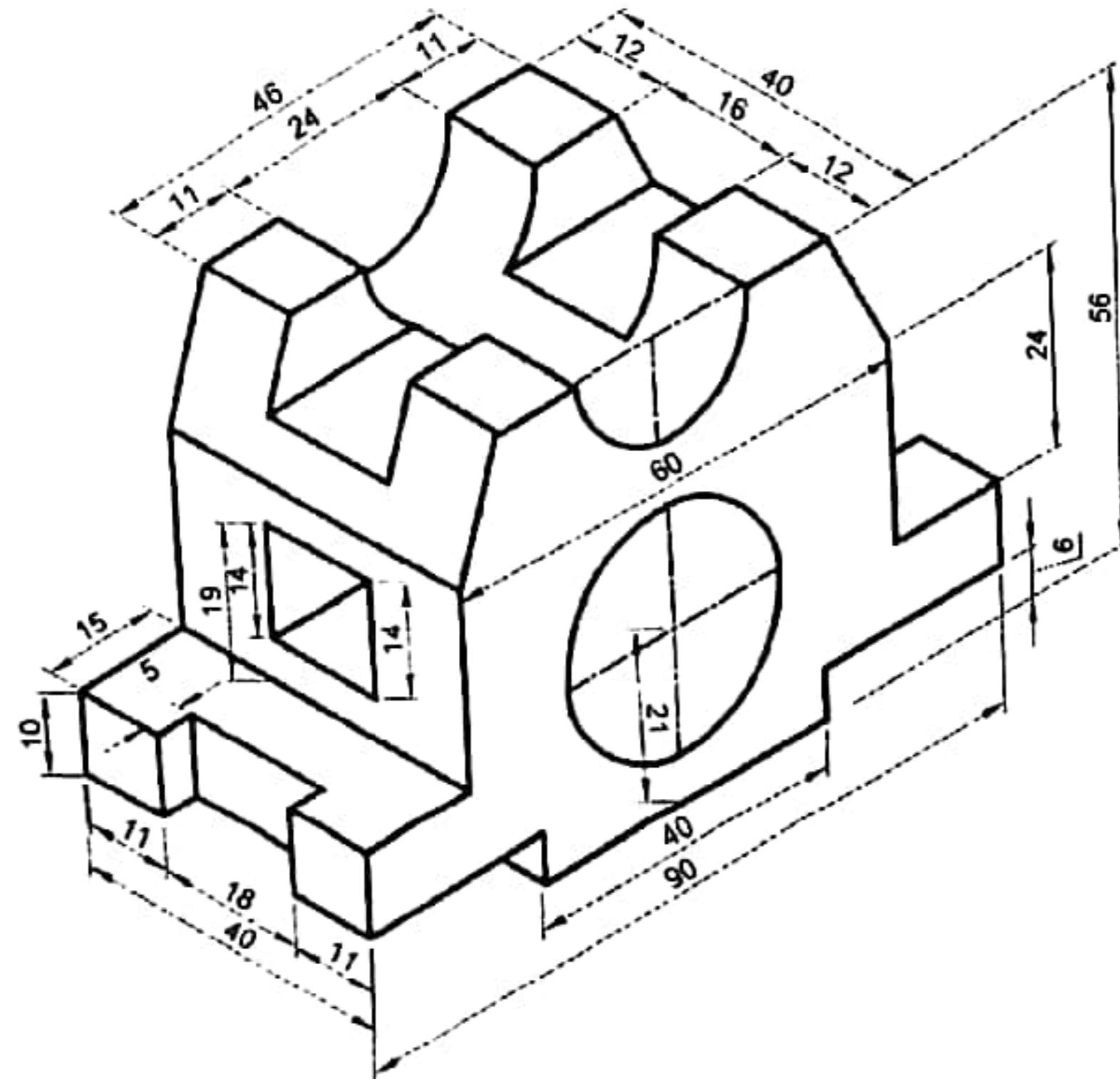

ISOMETRIC VIEW OF GIVEN SOLID

FULL SECTIONAL FRONT VIEW

LEFT SIDE VIEW

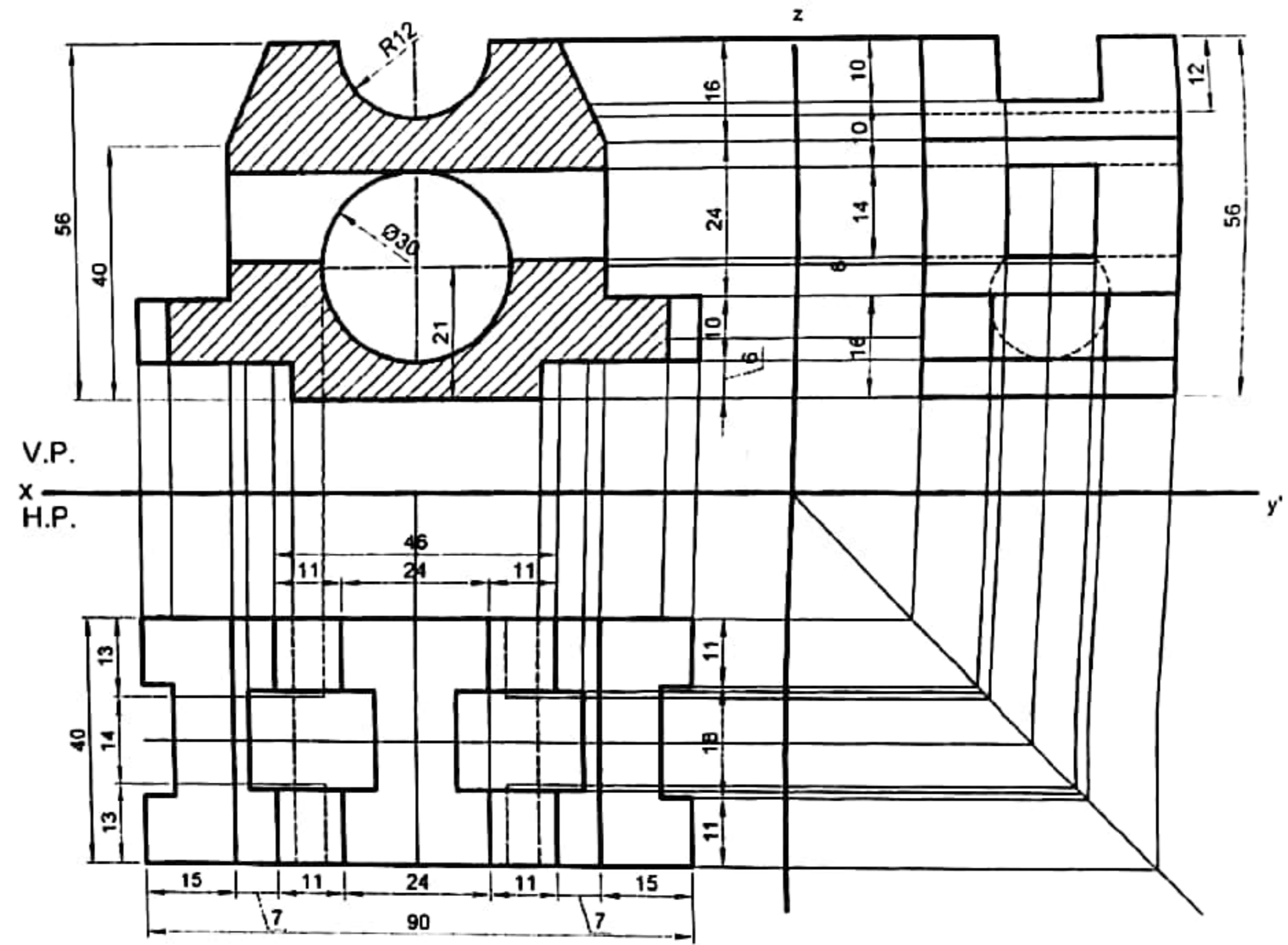

TOP VIEW

	SUBJECT	TITLE	DRAWN BY	CHECKED BY	DATE	SCALE
	ENGINEERING DRAWING	SECTION ORTHOGRAPHIC PROJECTION SHOWING THE FULL AND HALF SECTIONAL VIEW	NAME ROLL NO			
				DATE	DRAWING NO 54	

ISOMETRIC VIEW
OF GIVEN SOLID

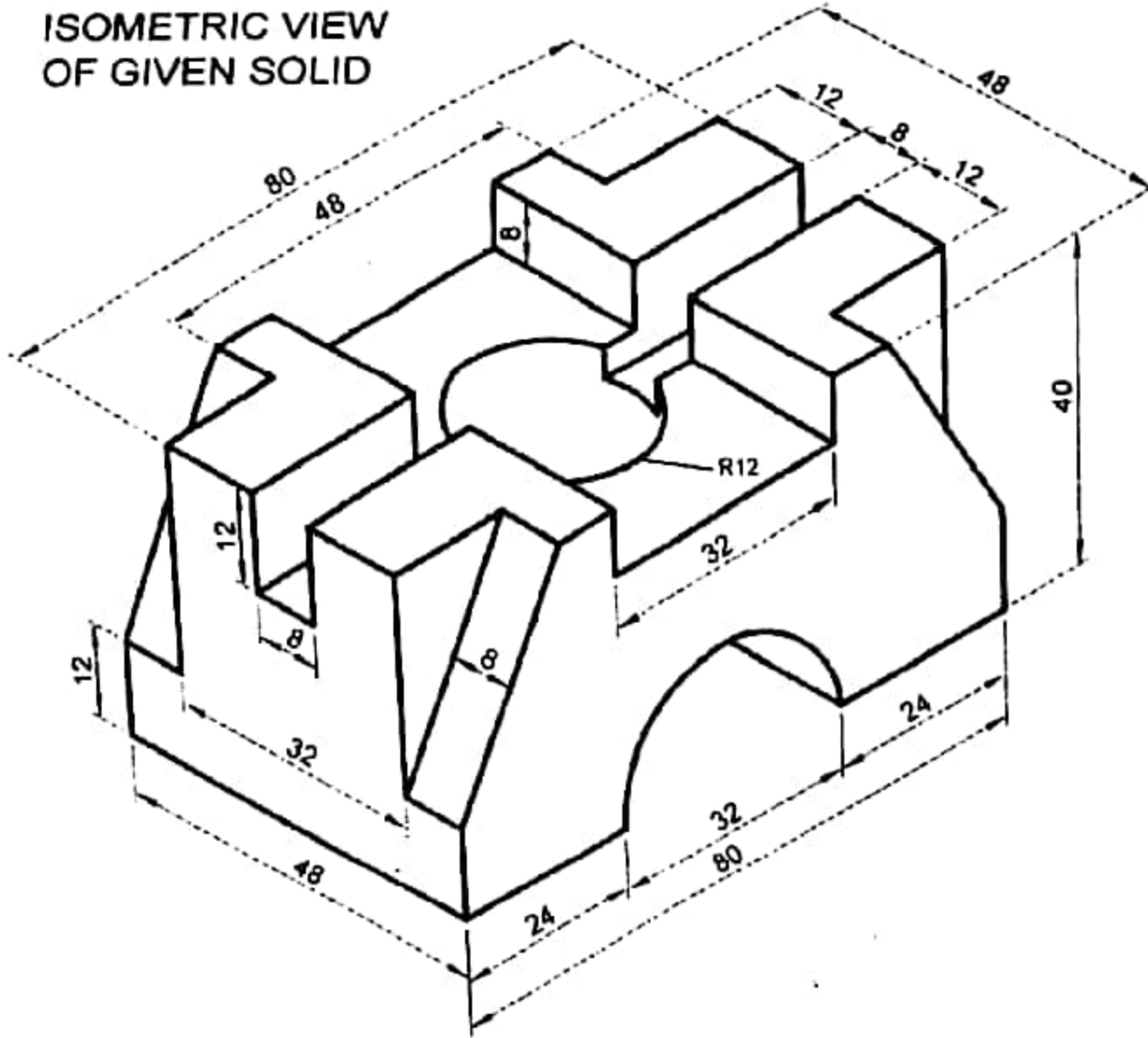

DRAW THE FULL SECTIONAL FRONT AND SIDE VIEW OF
GIVEN SOLID WHICH FIGURE IS GIVEN ABOVE

FULL SECTIONAL FRONT VIEW

LEFT SIDE VIEW

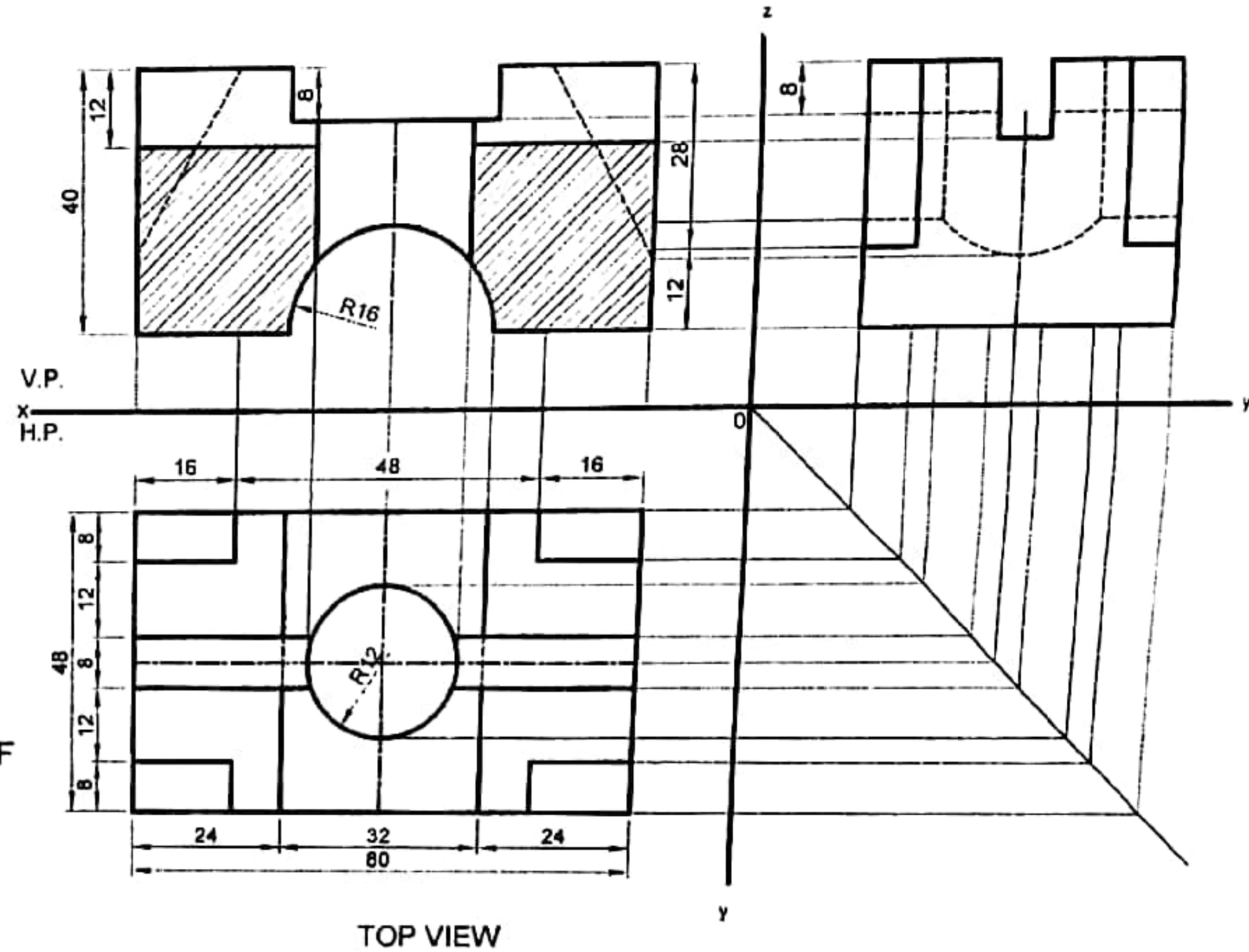

TOP VIEW

SUBJECT ENGINEERING DRAWING	TITLE SECTION ORTHOGRAPHIC PROJECTION SHOWING THE FULL AND HALF SECTIONAL VIEW	DRAWN BY NAME ROLL NO	CHECKED BY	DATE	SCALE
				DRAWING NO 55	

ISOMETRIC VIEW
OF GIVEN SOLID

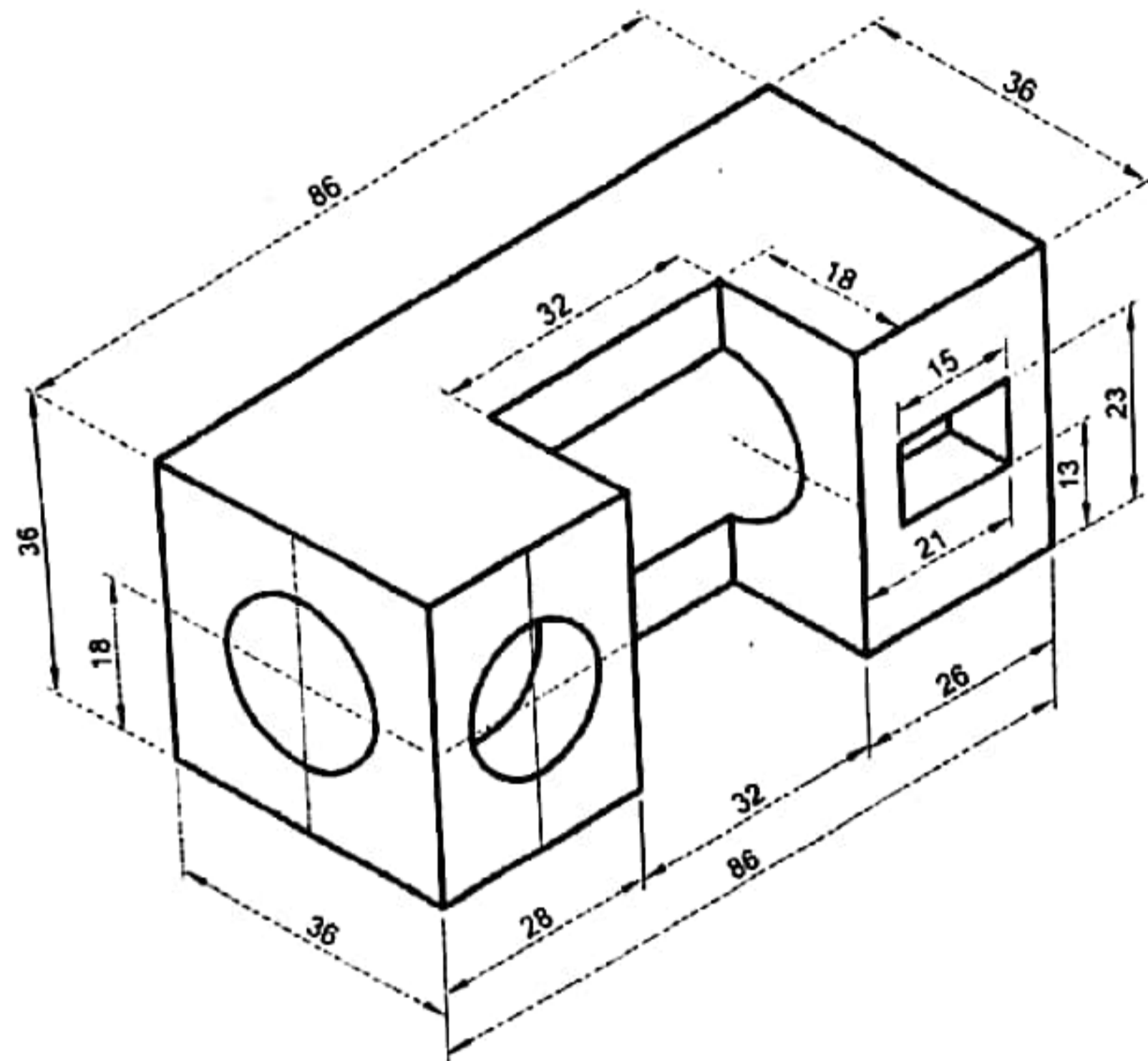

FRONT VIEW

LEFT SIDE VIEW

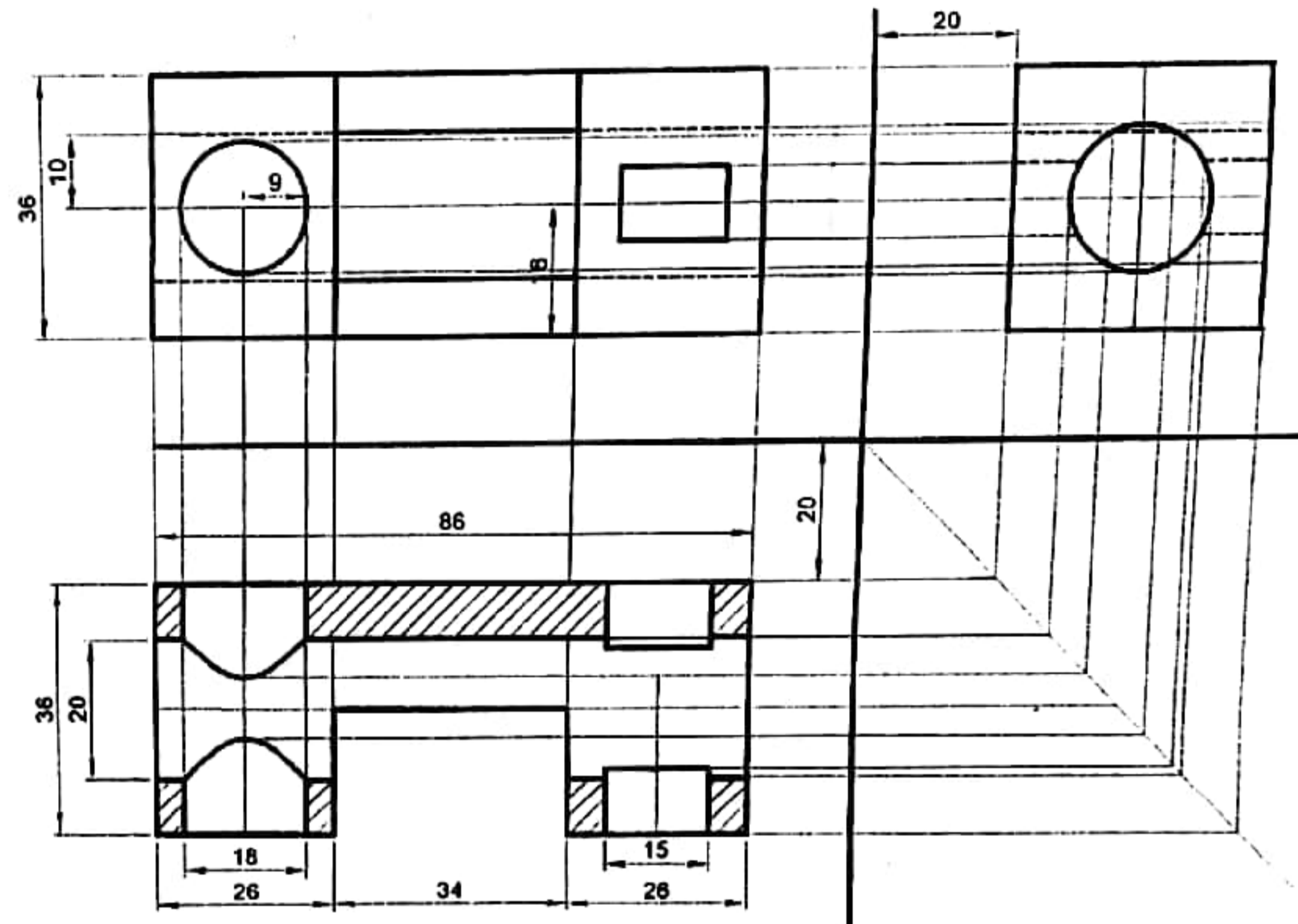

FULL SECTIONAL (HORIZONTAL SECTION) TOP VIEW

DRAW THE SECTIONAL FRONT AND SIDE VIEW OF
GIVEN SOLID WHICH FIGURE IS GIVEN ABOVE

	SUBJECT	TITLE	DRAWN BY	CHECKED BY	DATE	SCALE
	ENGINEERING DRAWING	SECTION ORTHOGRAPHIC PROJECTION SHOWING THE FULL AND HALF SECTIONAL VIEW	NAME ROLL NO			
				DATE	DRAWING NO	56

ISOMETRIC VIEW
OF GIVEN SOLID

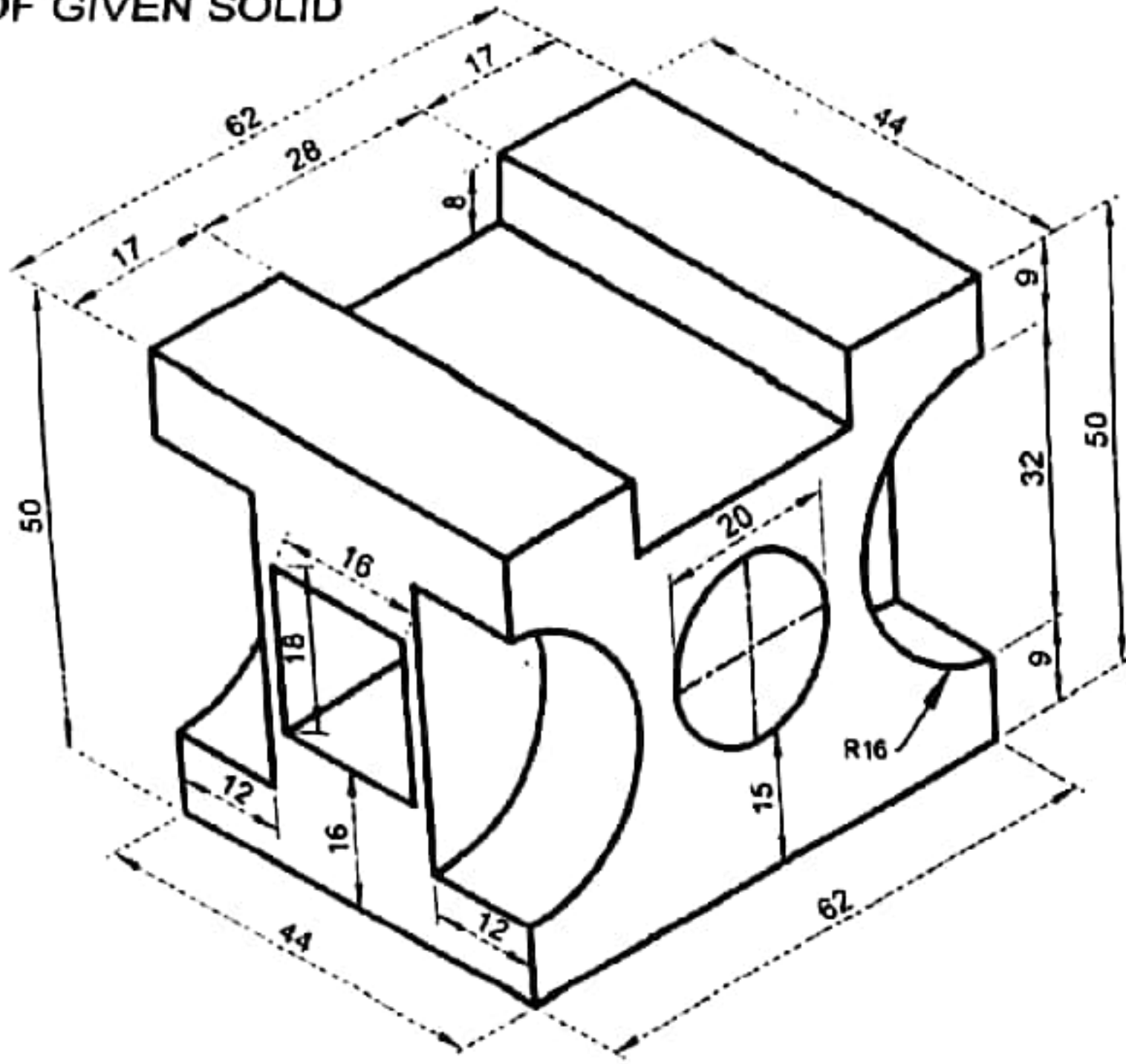

FRONT VIEW

LEFT SIDE VIEW

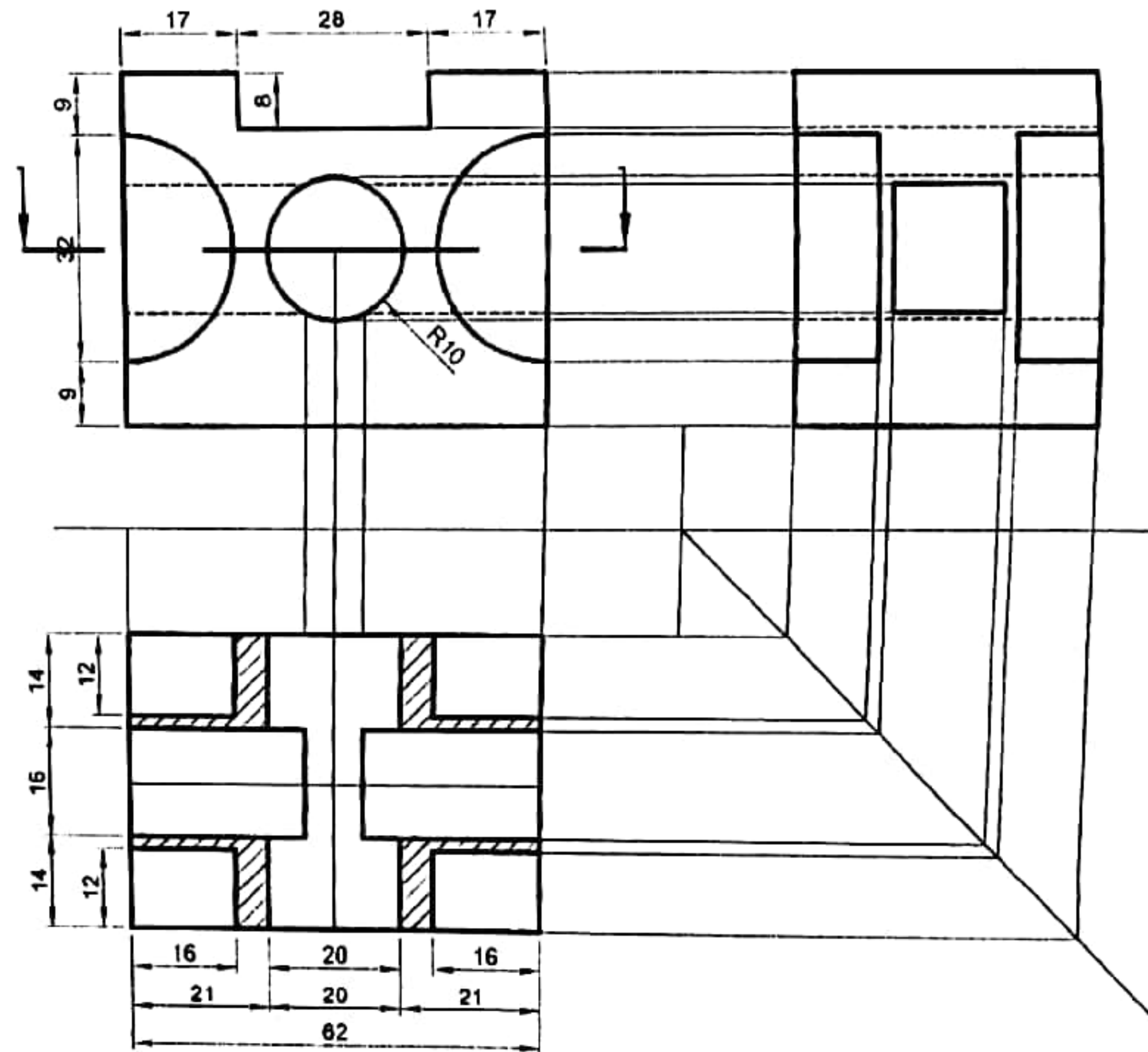

DRAW THE HORIZONTAL SECTIONAL TOP VIEW, FRONT VIEW
AND SIDE VIEW OF SOLID WHICH FIGURE IS GIVEN ABOVE

FULL SECTIONAL (HORIZONTAL SECTION) TOP VIEW

	SUBJECT	TITLE	DRAWN BY	CHECKED BY	DATE	SCALE
	ENGINEERING DRAWING	SECTION ORTHOGRAPHIC PROJECTION SHOWING THE FULL AND HALF SECTIONAL VIEW	NAME ROLL NO	DATE	DRAWING NO	57

ISOMETRIC VIEW OF GIVEN SOLID

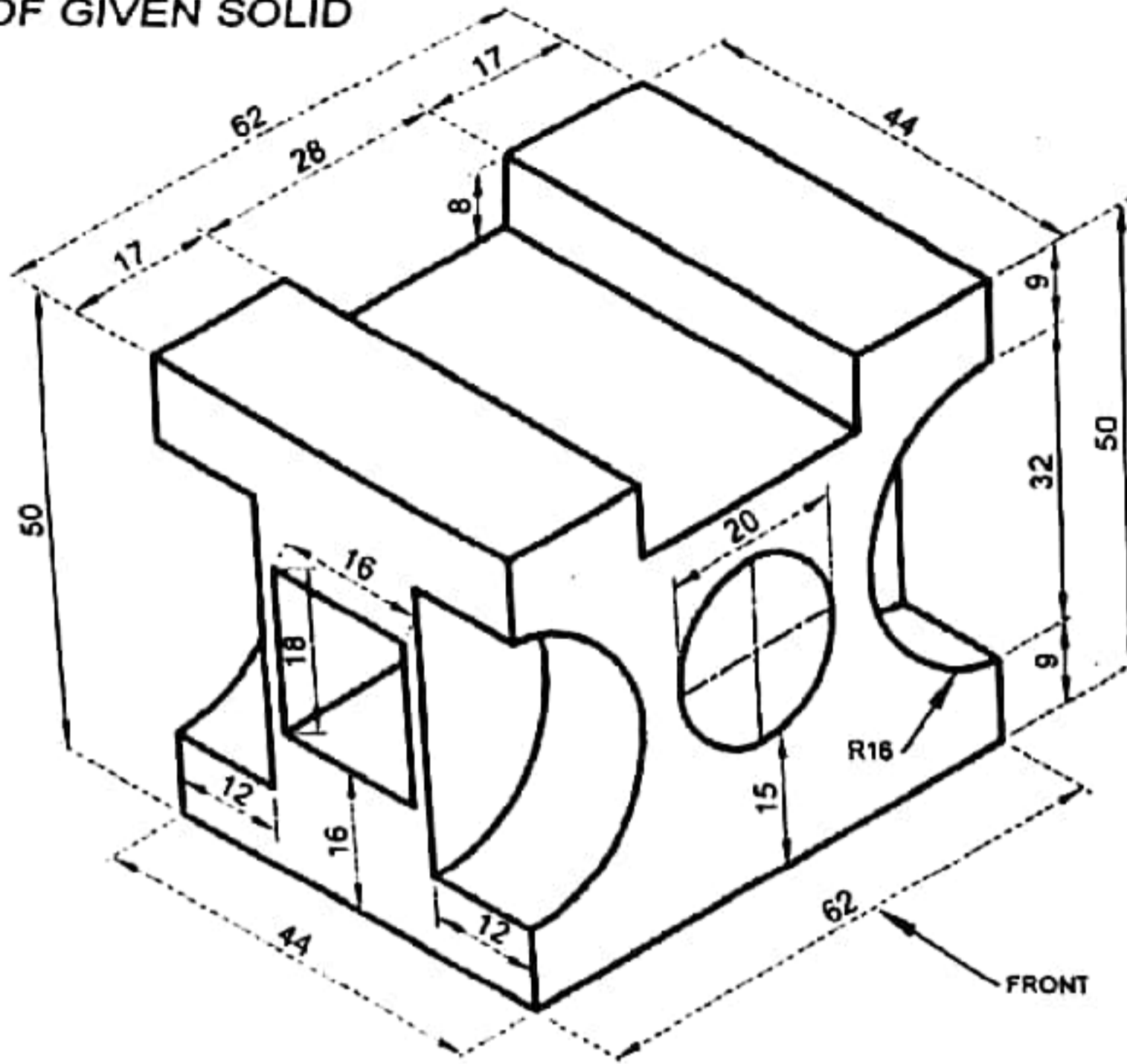

FULL SECTIONAL FRONT VIEW

LEFT SIDE VIEW

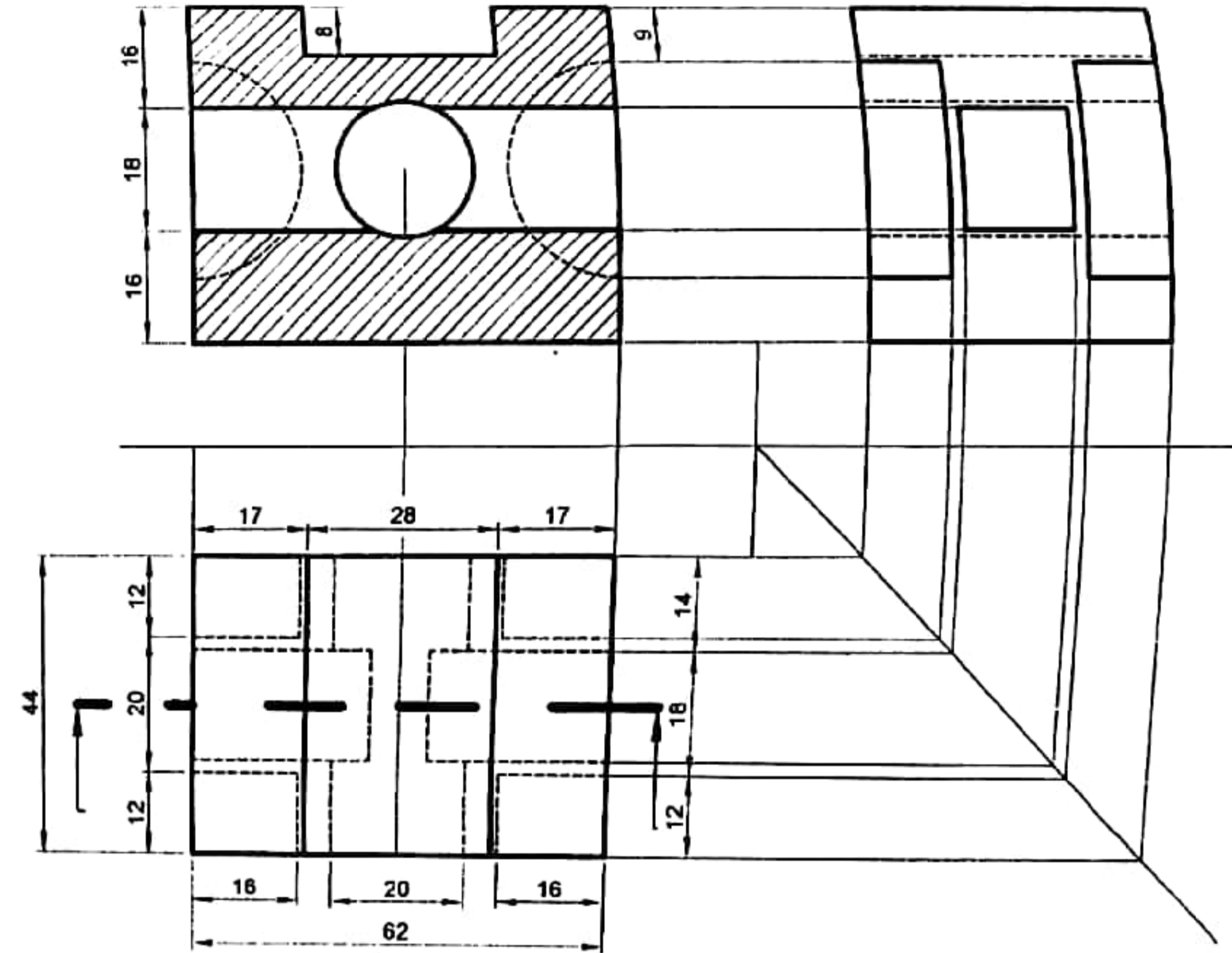

DRAW THE FULL SECTIONAL FRONT VIEW, TOP VIEW, AND SIDE VIEW OF SOLID WHICH FIGURE IS GIVEN ABOVE

TOP VIEW

	SUBJECT	TITLE	DRAWN BY	CHECKED BY	DATE	SCALE
	ENGINEERING DRAWING	SECTION ORTHOGRAPHIC PROJECTION SHOWING THE FULL AND HALF SECTIONAL VIEW	NAME ROLL NO	DATE	DRAWING NO	58

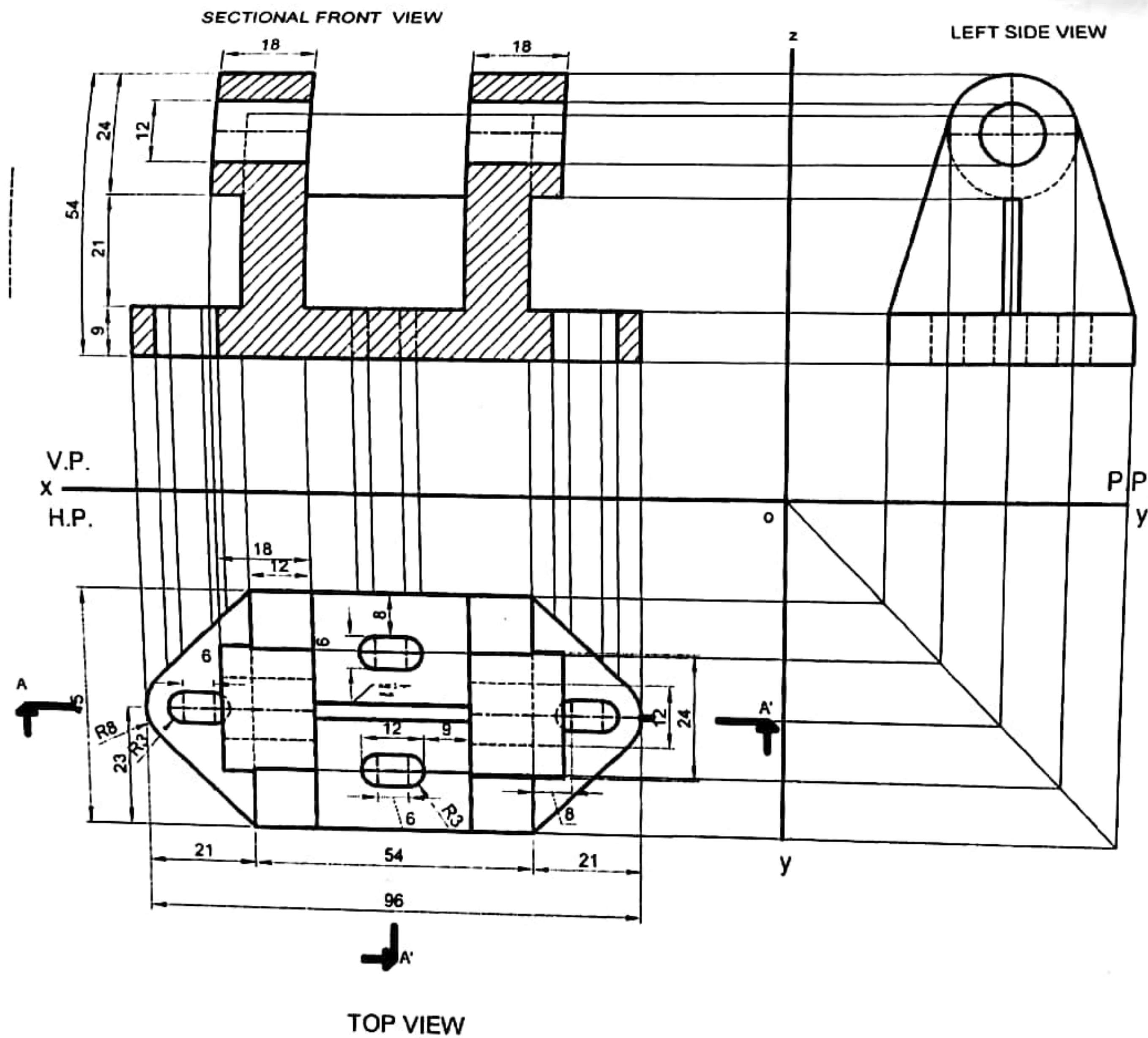

ISOMETRIC VIEW OF GIVEN SOLID

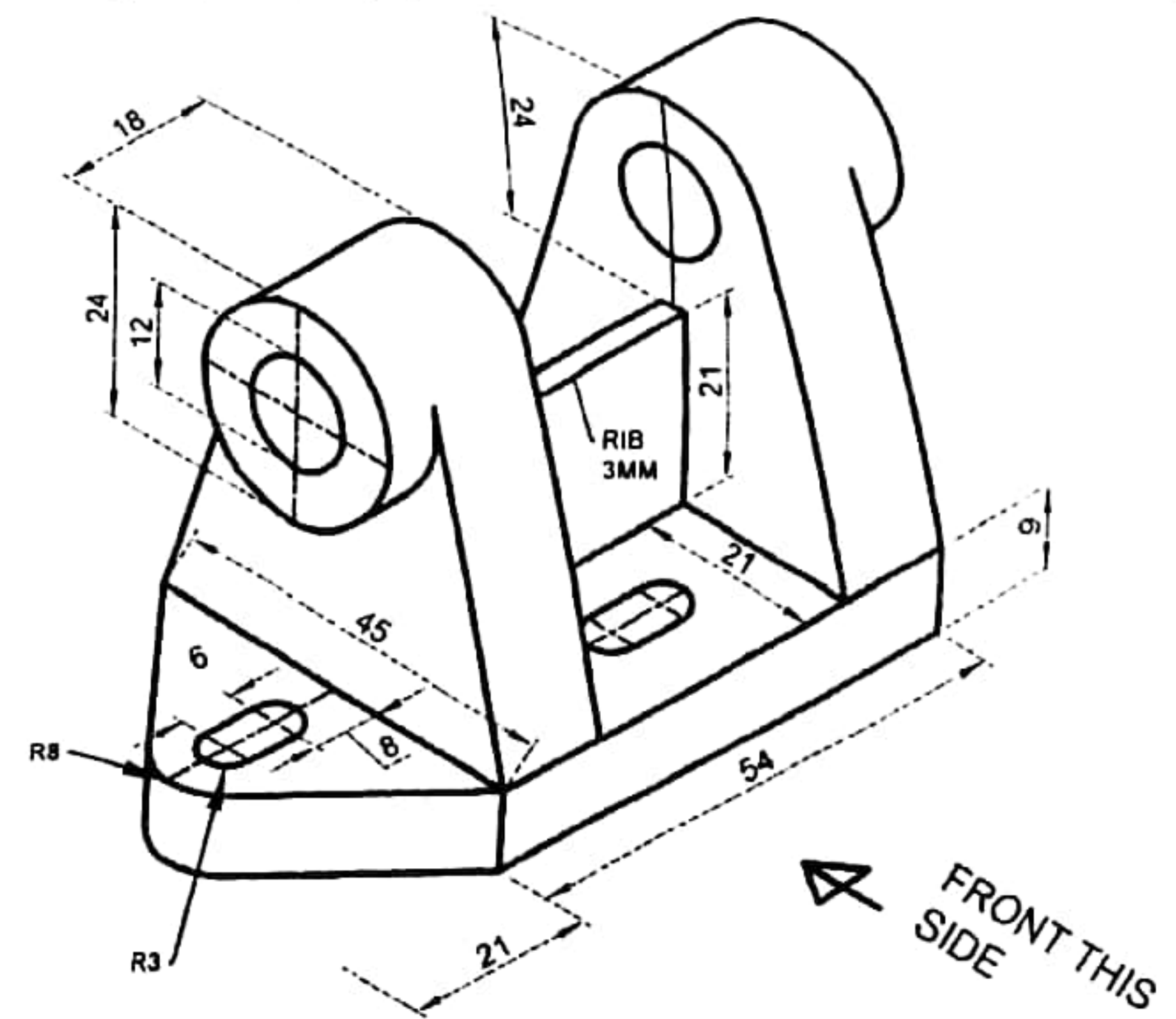

ISOMETRIC VIEW OF GIVEN SOLID

DRAW FULL SECTIONAL FRONT VIEW OF GIVEN SOLID

SUBJECT ENGINEERING DRAWING	TITLE SECTION ORTHOGRAPHIC PROJECTION SHOWING THE FULL AND HALF SECTIONAL VIEW	DRAWN BY NAME ROLL NO	CHECKED BY DATE	DATE	SCALE
				DRAWING NO 59	

DRAW THE SECTIONAL FRONT AND SIDE VIEW OF GIVEN SOLID GIVEN BELOW

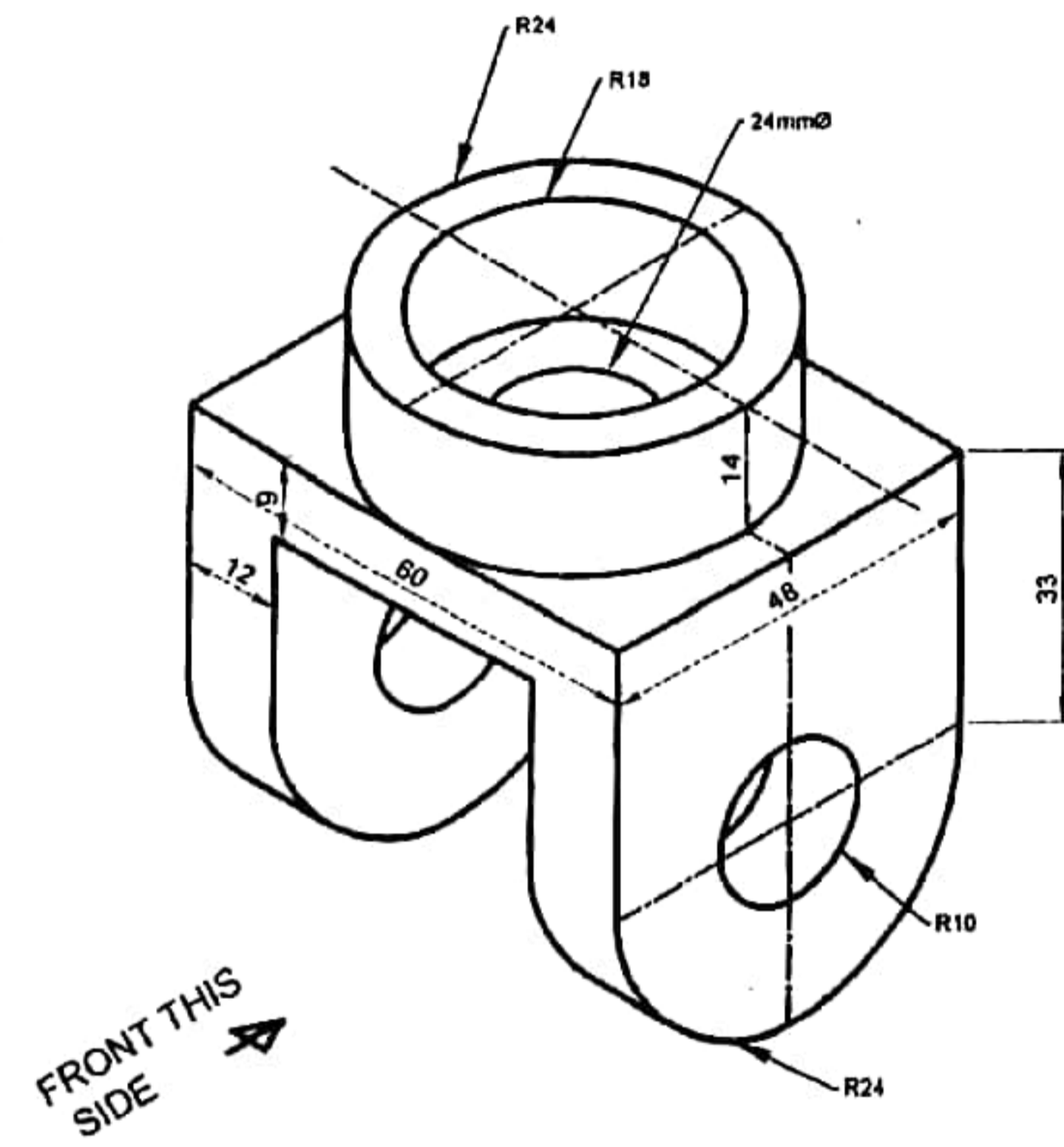

ISOMETRIC VIEW OF GIVEN SOLID

DRAW HALF SECTIONAL SIDE VIEW OF GIVEN SOLID

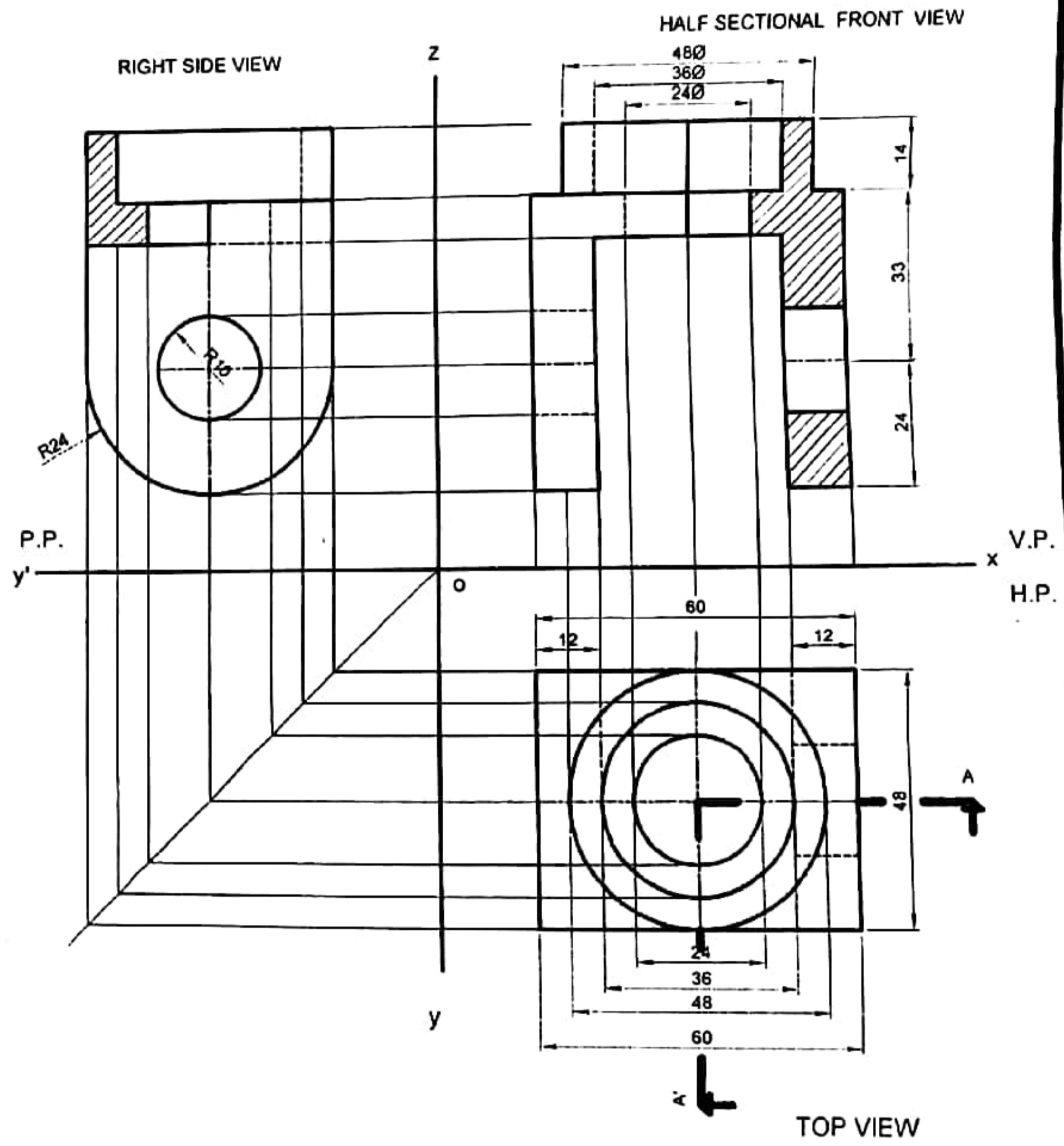

	SUBJECT	TITLE	DRAWN BY	CHECKED BY	DATE	SCALE
	ENGINEERING DRAWING	SECTION ORTHOGRAPHIC PROJECTION SHOWING THE FULL AND HALF SECTIONAL VIEW	NAME ROLL NO			
				DATE	DRAWING NO	60

DRAW THE HALF SECTIONAL FRONT AND SIDE VIEW OF GIVEN SOLID GIVEN BELOW

ISOMETRIC VIEW OF GIVEN SOLID

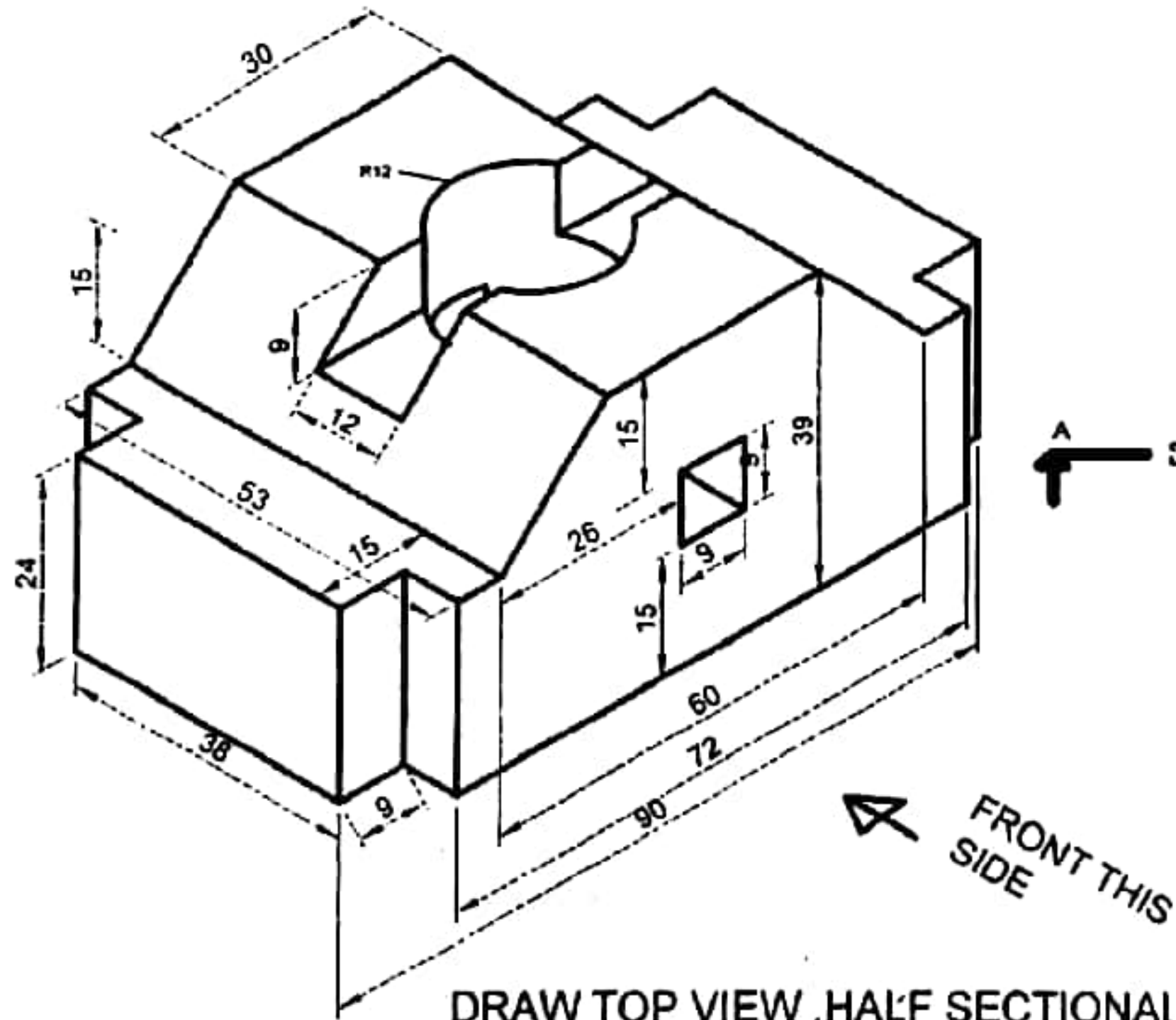

DRAW TOP VIEW, HALF SECTIONAL FRONT AND SIDE VIEWS OF GIVEN SOLID WHICH FIGURE IS GIVEN ABOVE,

HALF SECTIONAL FRONT VIEW

LEFT SIDE VIEW

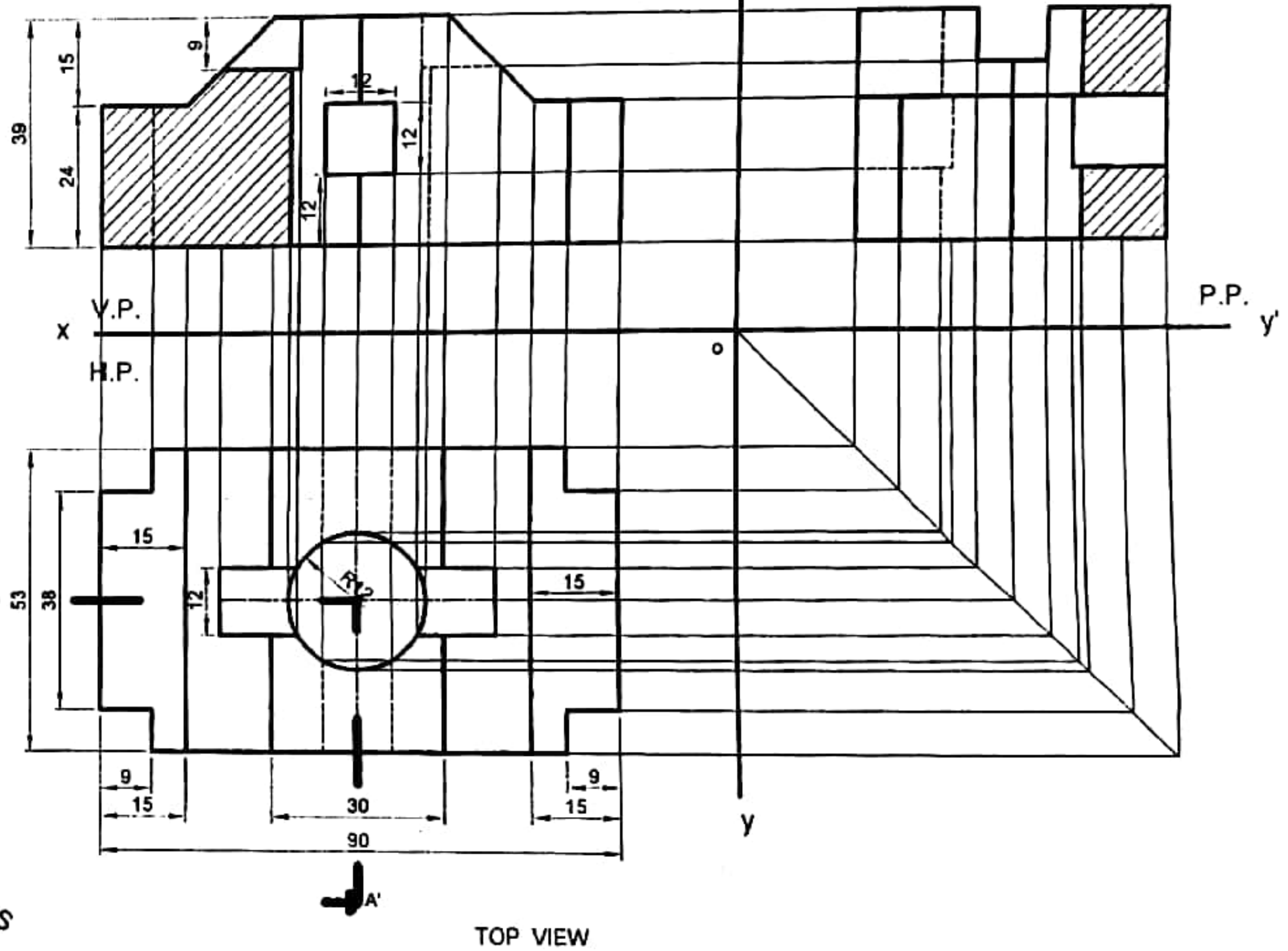

SUBJECT
ENGINEERING DRAWING

TITLE
SECTION
ORTHOGRAPHIC PROJECTION
SHOWING THE FULL AND HALF
SECTIONAL VIEW

DRAWN BY
NAME
ROLL NO

CHECKED BY
DATE

DATE

SCALE

DRAWING NO

61

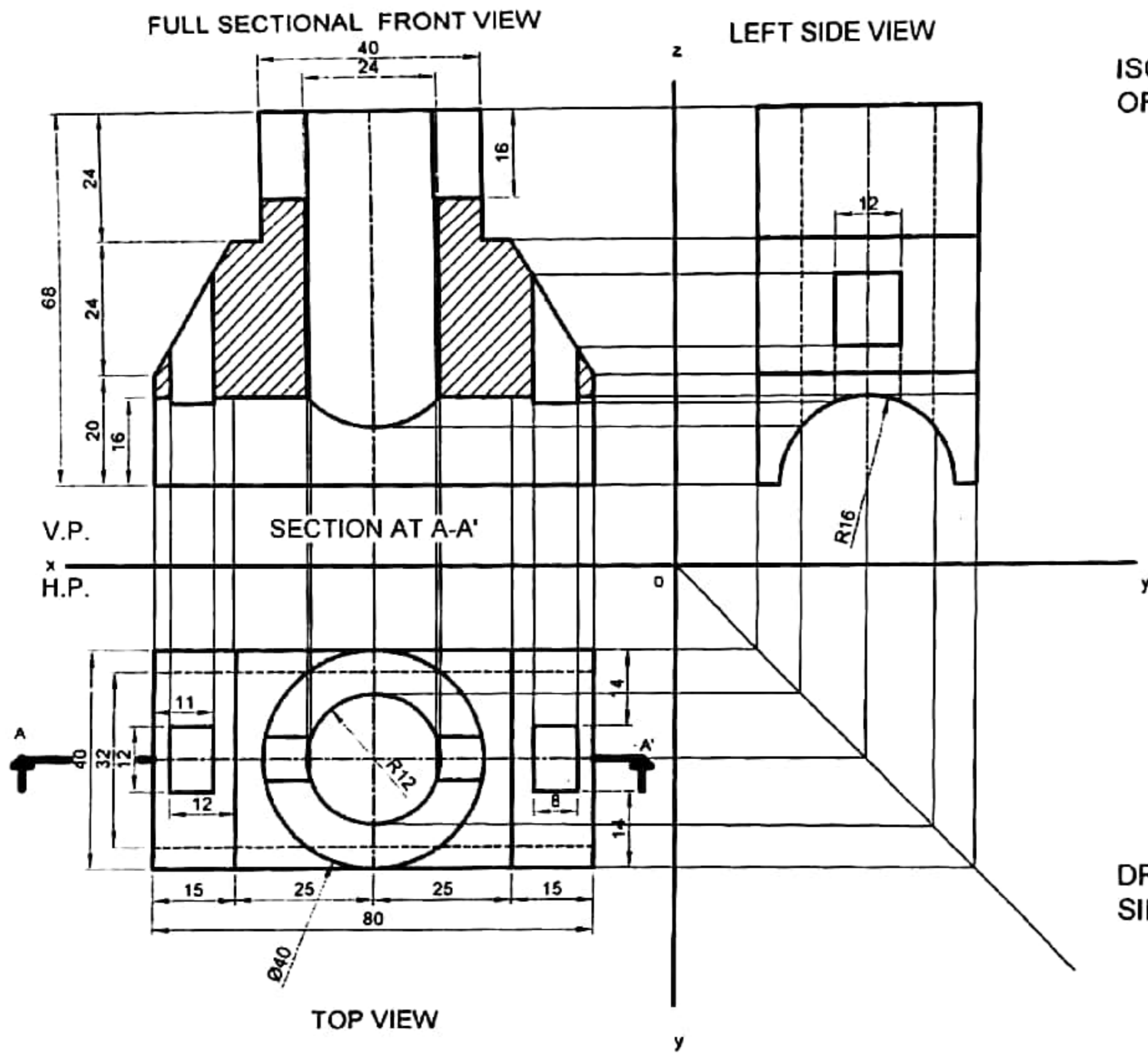

ISOMETRIC VIEW OF GIVEN SOLID

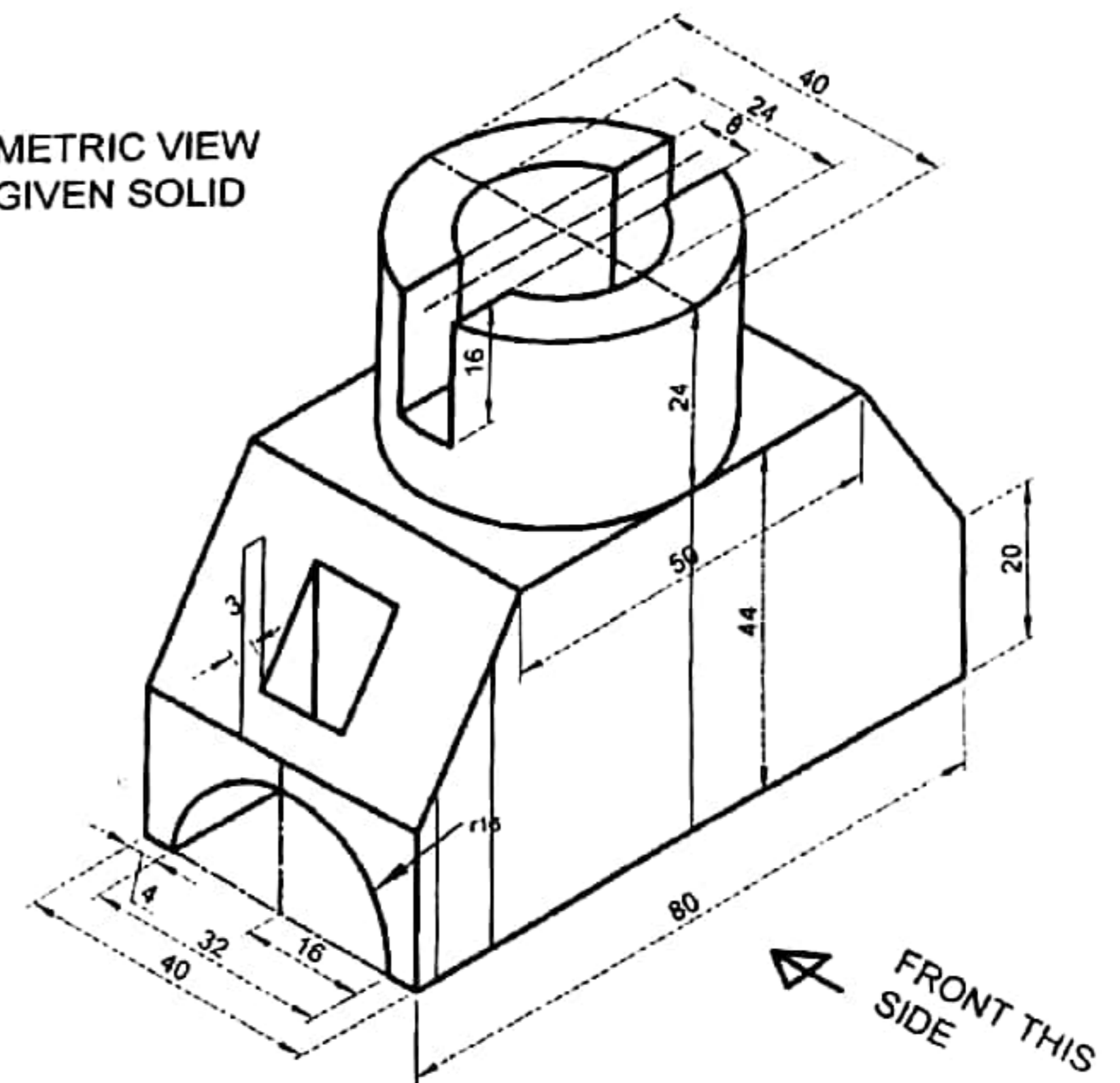

DRAW THE FULL SECTIONAL FRONT VIEW, TOP VIEW, AND SIDE VIEW OF SOLID WHICH FIGURE IS GIVEN ABOVE

	SUBJECT	TITLE	DRAWN BY	CHECKED BY	DATE	SCALE
	ENGINEERING DRAWING	SECTION ORTHOGRAPHIC PROJECTION SHOWING THE FULL AND HALF SECTIONAL VIEW	NAME ROLL NO			
				DATE	DRAWING NO 63	

1. A square base prism of base edge is 18 x 18 mm and 30 mm high, it is rested on HP by its base, its two edges of base are equally inclined to VP at 45°. It is cut by a vertical projecting plane which is inclined to HP 30° and perpendicular to VP as shown on figure, Now you are asked to draw the three plane projection and complete the whole surface development.

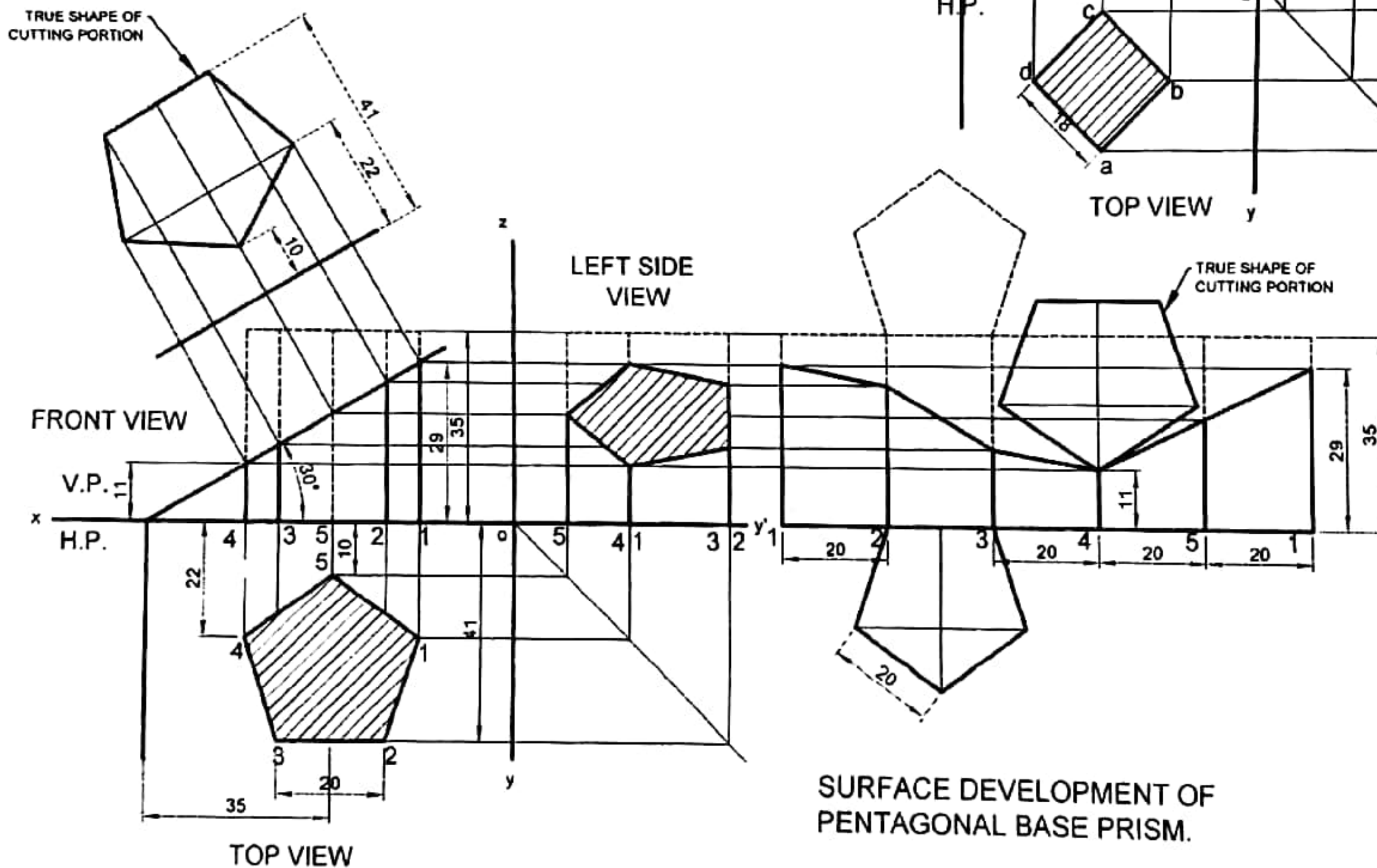
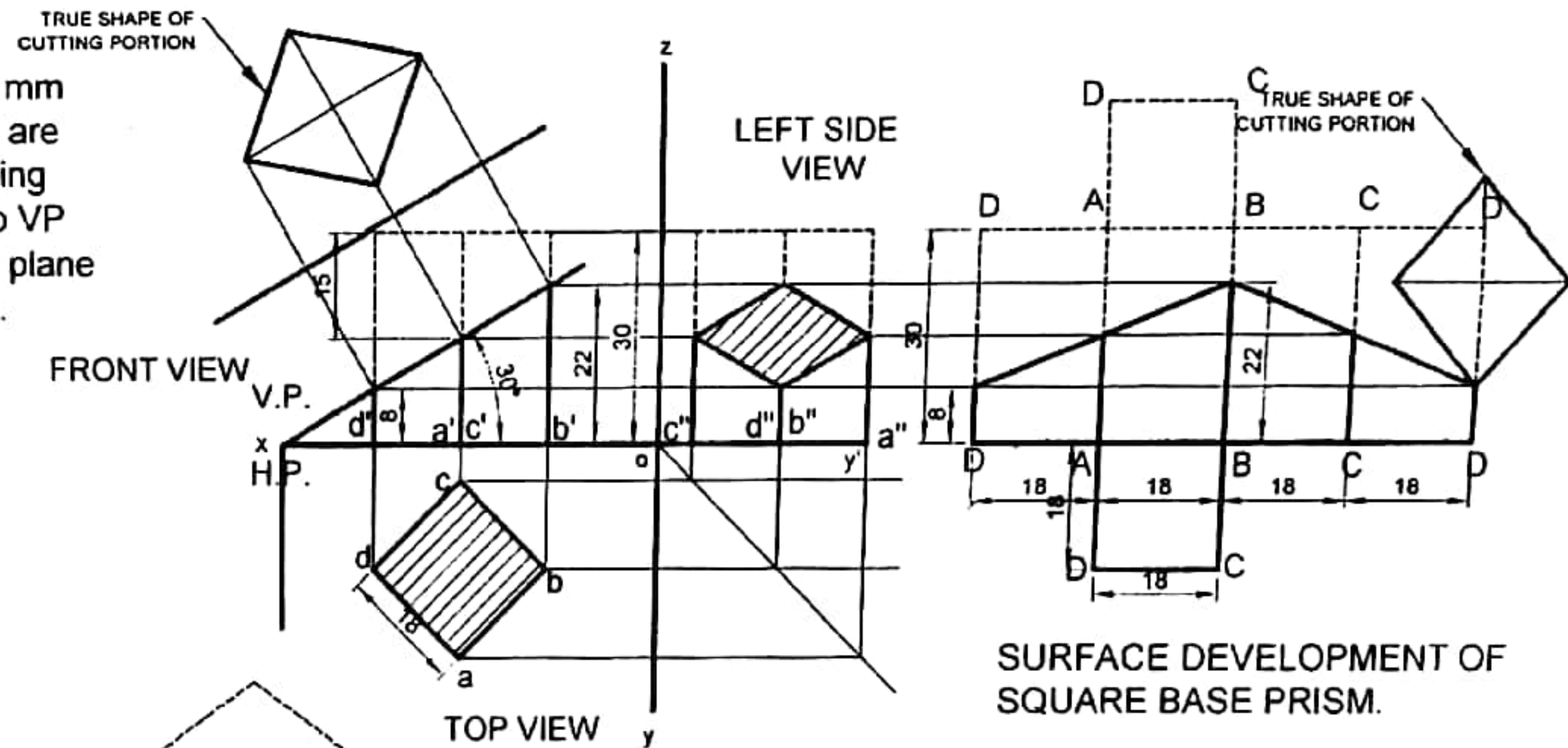

2. A pentagonal base prism of base edge is 20 mm and 35 mm high, it is rested on HP by its base, its one edge of base is parallel to VP. It is cut by a vertical projecting plane which is inclined to HP 30° and perpendicular to VP as shown on figure, Now you are asked to draw the three plane projection and complete the whole surface development.

Draw the above mention drawing in 2:1 scale.

TRIPUVAN UNIVERSITY INSTITUTE OF ENGINEERING THAPATHALI CAMPUS MAITIGHAR, KATHMANDU	SUBJECT ENGINEERING DRAWING	TITLE SURFACE DEVELOPMENT OF GEOMETRICAL SOLIDS (WITH TRUNCATED), FINDING TRUE SHAPE	DRAWN BY NAME ROLL NO	CHECKED BY	DATE	SCALE
					DATE	DRAWING NO 65

1. A hexagonal base prism of base edge is 15 mm and 30 mm high, it is rested on HP by its base, its two edges of base is parallel to VP. It is cut by a vertical projecting plane which is inclined to HP at 29° and perpendicular to VP as shown on figure, Now you are asked to draw the three plane projection and complete the whole surface development.

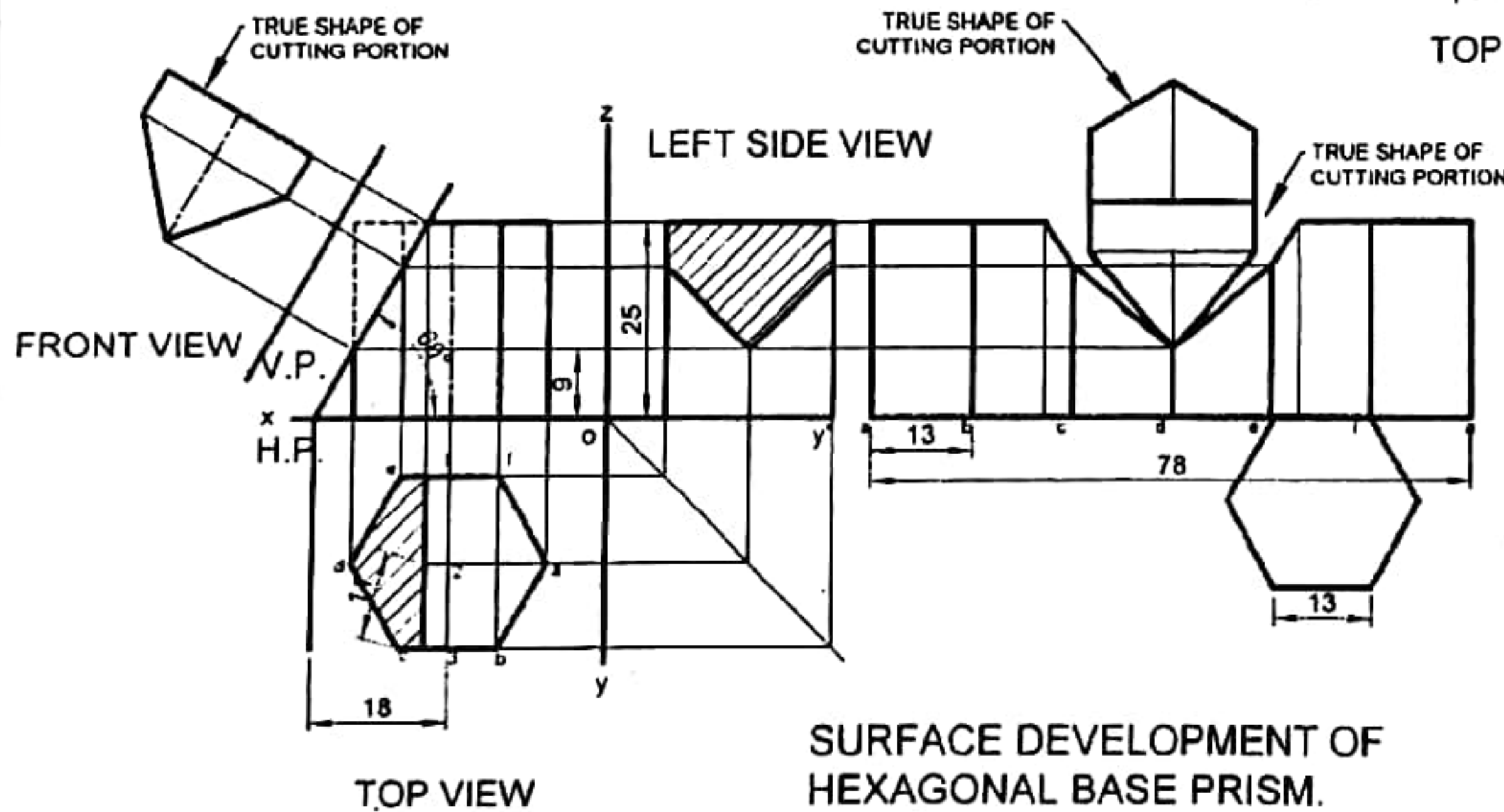
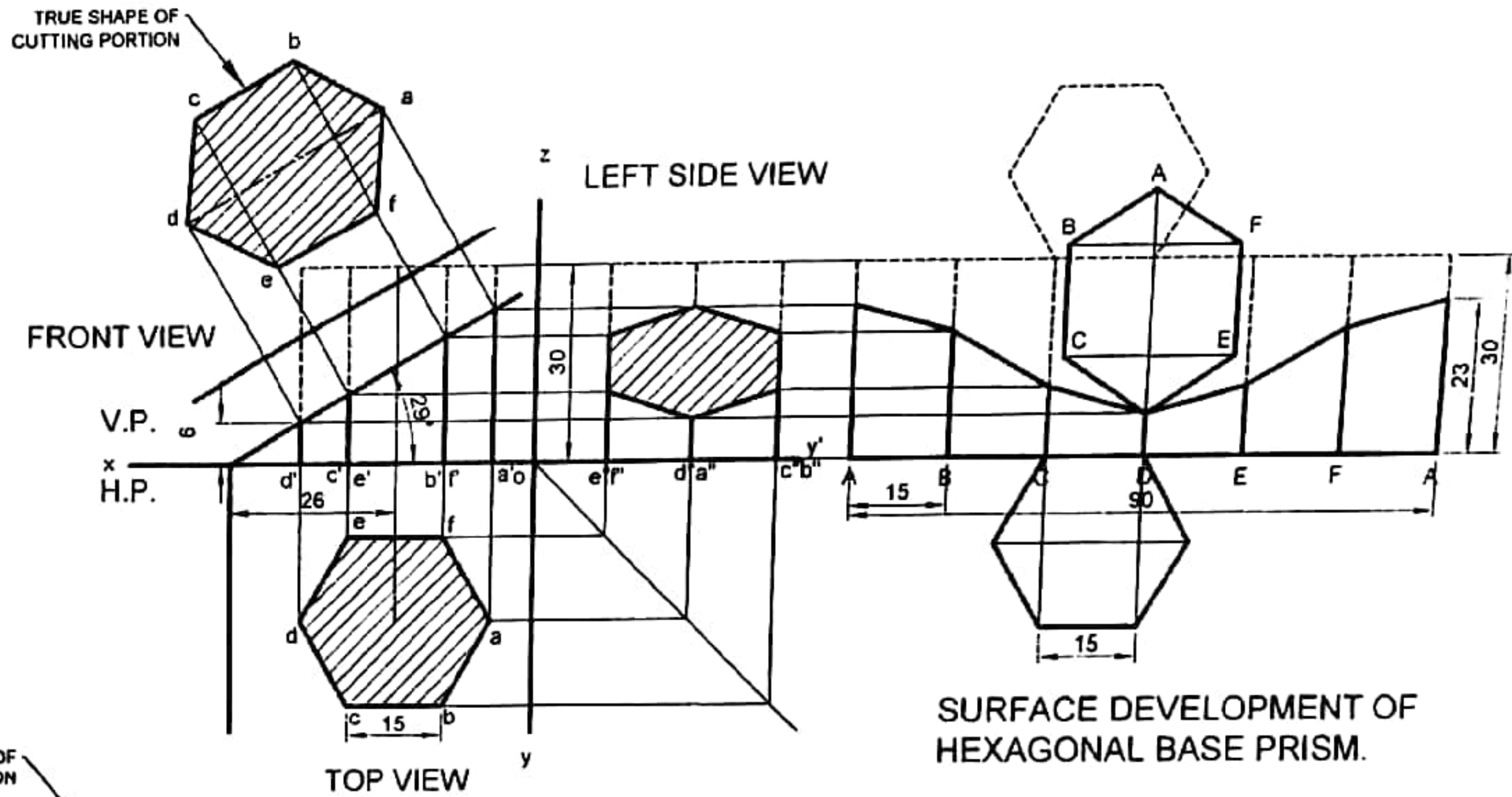

1. A hexagonal base prism of base edge is 13 mm and 25 mm high, it is rested on HP by its base, its two edges of base is parallel to VP. It is cut by a vertical projecting plane which is inclined to HP at 60° and perpendicular to VP as shown on figure, Now you are asked to draw the three plane projection and complete the whole surface development.

Draw the above mention drawing in 2:1 scale.

TRIBHUVAN UNIVERSITY INSTITUTE OF ENGINEERING THAPATHALI CAMPUS MAITIGHAR, KATHMANDU	SUBJECT ENGINEERING DRAWING	TITLE SURFACE DEVELOPMENT OF GEOMETRICAL SOLIDS (WITH TRUNCATED). FINDING TRUE SHAPE	DRAWN BY NAME ROLL NO	CHECKED BY DATE	DATE	SCALE
					DRAWING NO	

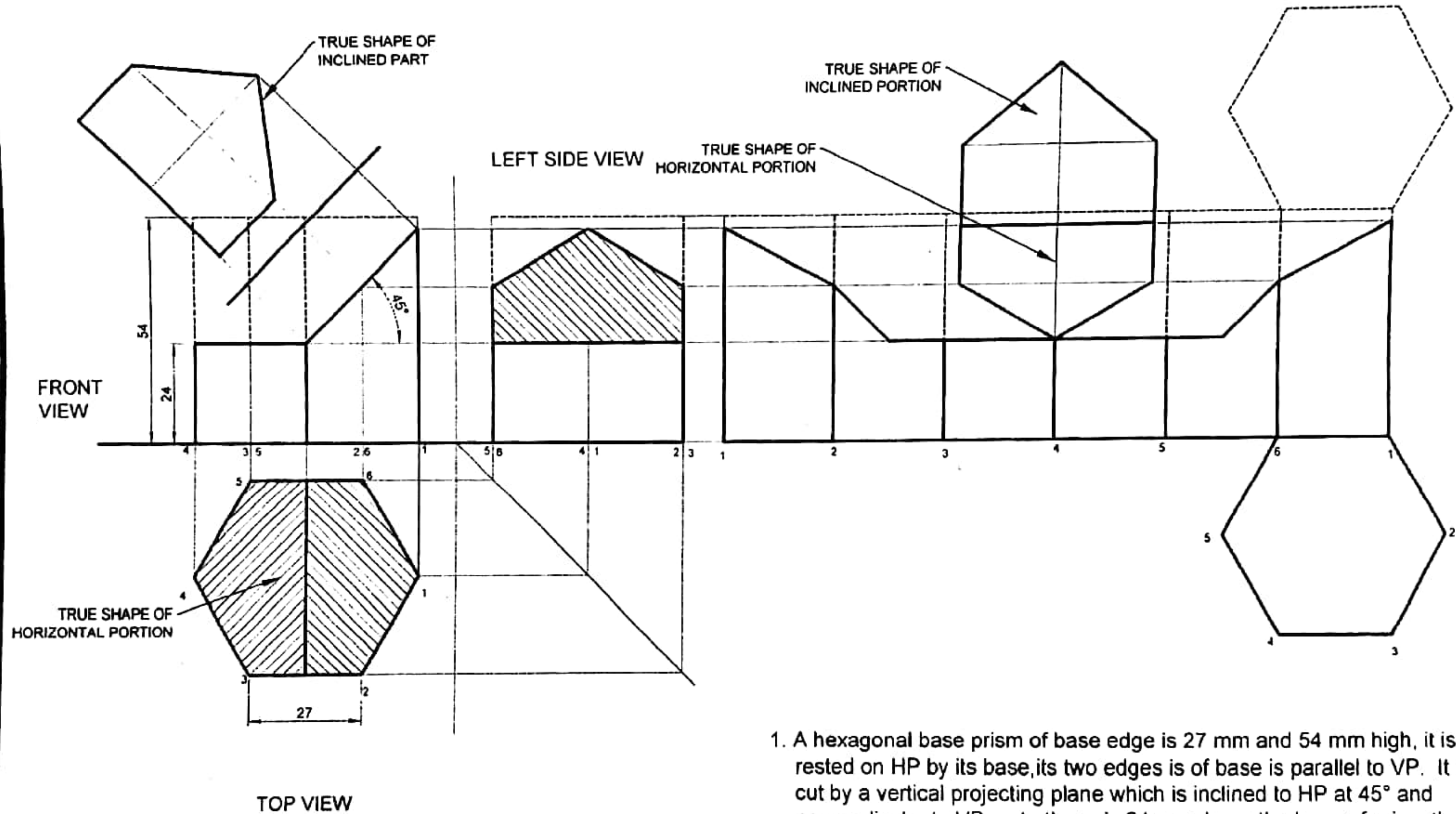

1. A hexagonal base prism of base edge is 27 mm and 54 mm high, it is rested on HP by its base, its two edges of base are parallel to VP. It is cut by a vertical projecting plane which is inclined to HP at 45° and perpendicular to VP up to the axis 24 mm above the base of prism then it is cut by another plane which is parallel to HP and perpendicular to VP as shown on figure. Now you are asked to draw the three plane projection and complete the whole surface development.

TRIBHUVAN UNIVERSITY
INSTITUTE OF ENGINEERING
THAPATHALI CAMPUS
MAITIGHAR, KATHMANDU

SUBJECT
ENGINEERING DRAWING

TITLE
SURFACE DEVELOPMENT OF
GEOMETRICAL SOLIDS
(WITH TRUNCATED),
FINDING TRUE SHAPE

DRAWN BY
NAME
ROLL NO

CHECKED BY
DATE

DATE

SCALE

DRAWING NO

67

1. Complete the three plane projection of 30 mm \varnothing and 30 mm high cylinder. it is cut by a sectional plane (vertical projecting) which is inclined to HP at 60° as shown on figure and complete the complete surface development of the same with true shape.

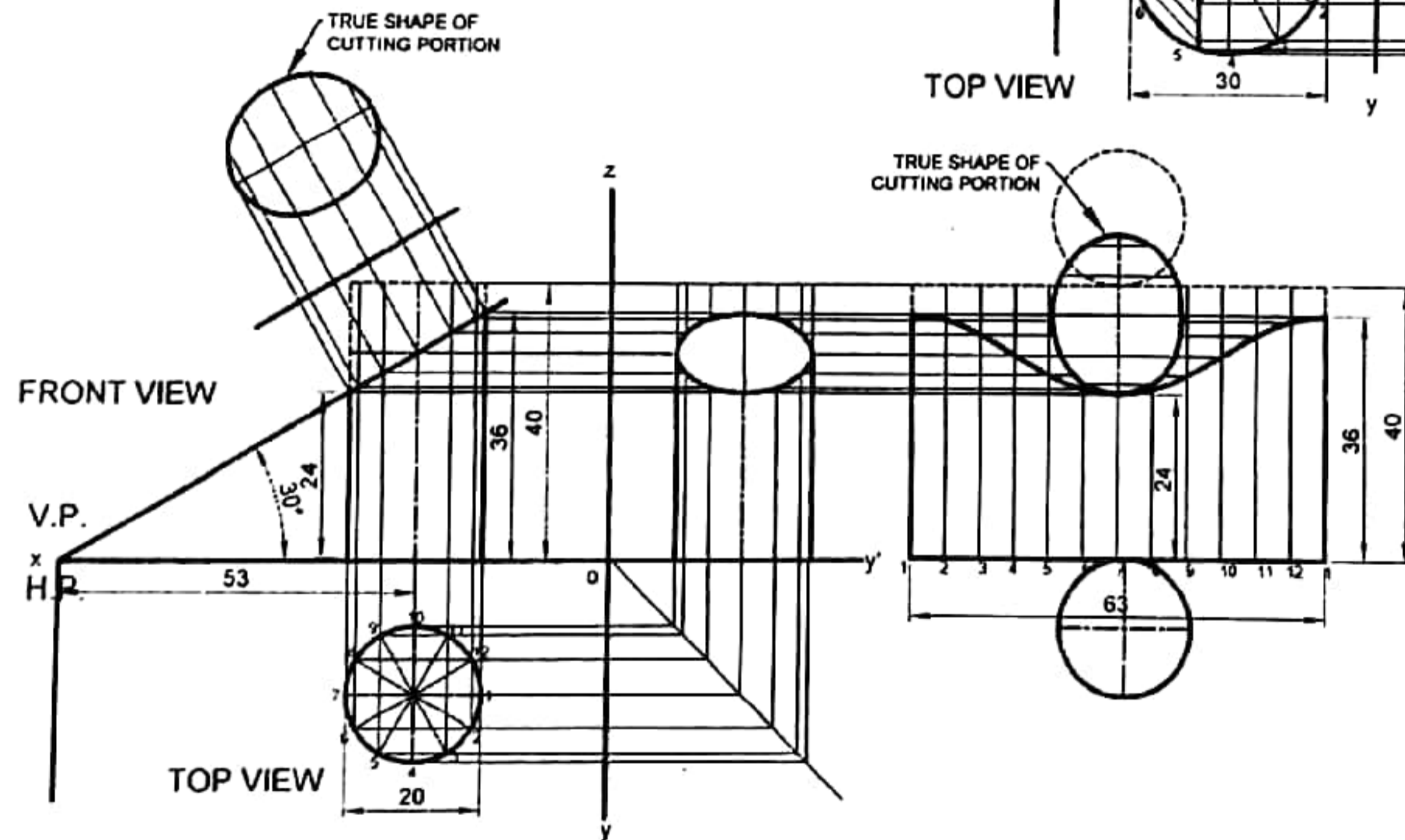
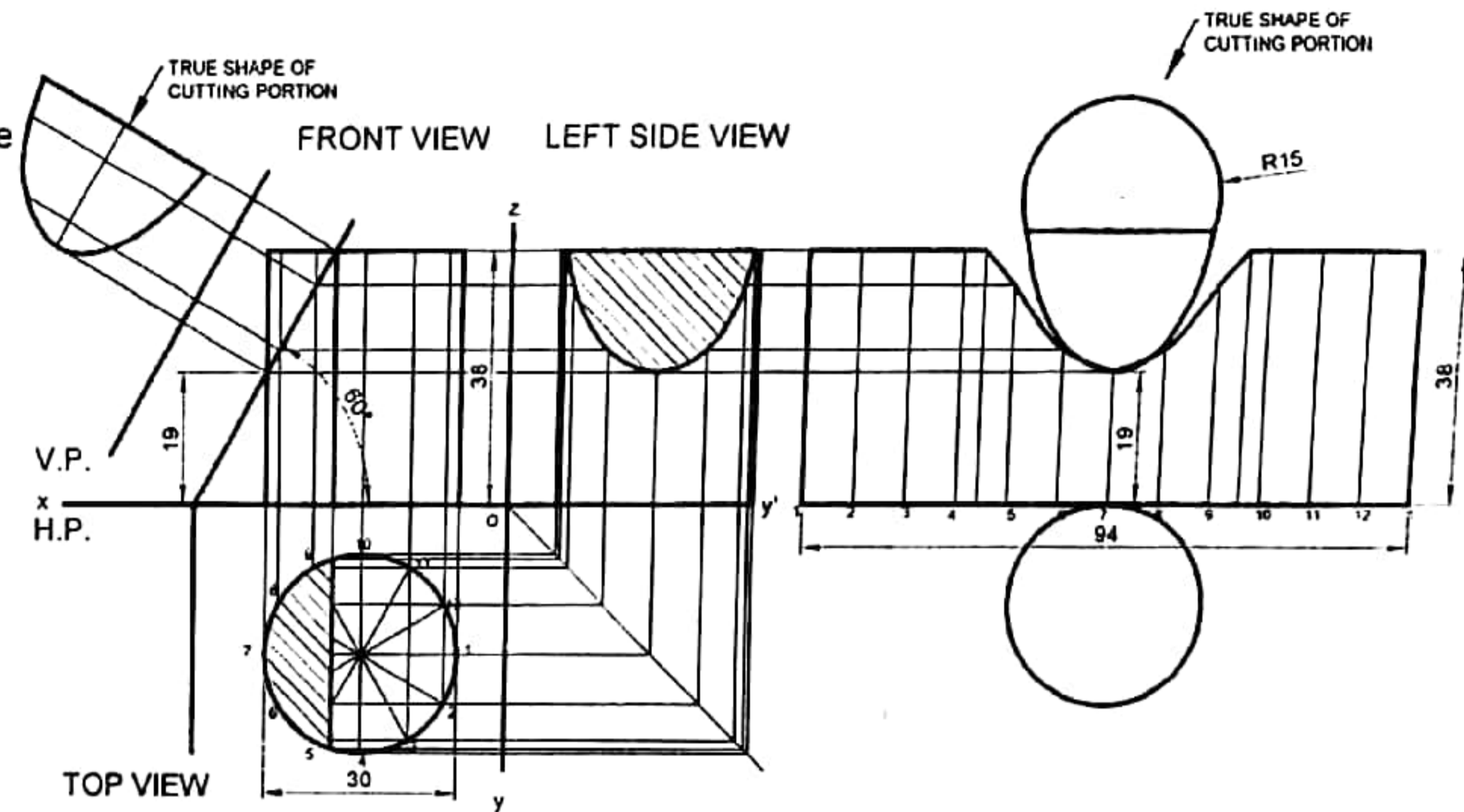

1. Complete the three plane projection of 20 mm \varnothing and 40 mm high cylinder. it is cut by a sectional plane (vertical projecting) which is inclined to HP at 30° as shown on figure and complete the complete surface development of the same with true shape.

Draw the above mention drawing in 2:1 scale.

TRIBHUVAN UNIVERSITY INSTITUTE OF ENGINEERING THAPATHALI CAMPUS MAITIGHAR, KATHMANDU	SUBJECT ENGINEERING DRAWING	TITLE SURFACE DEVELOPMENT OF GEOMETRICAL SOLIDS (WITH TRUNCATED) FINDING TRUE SHAPE	DRAWN BY NAME ROLL NO	CHECKED BY DATE	DATE	SCALE
					DRAWING NO 68	

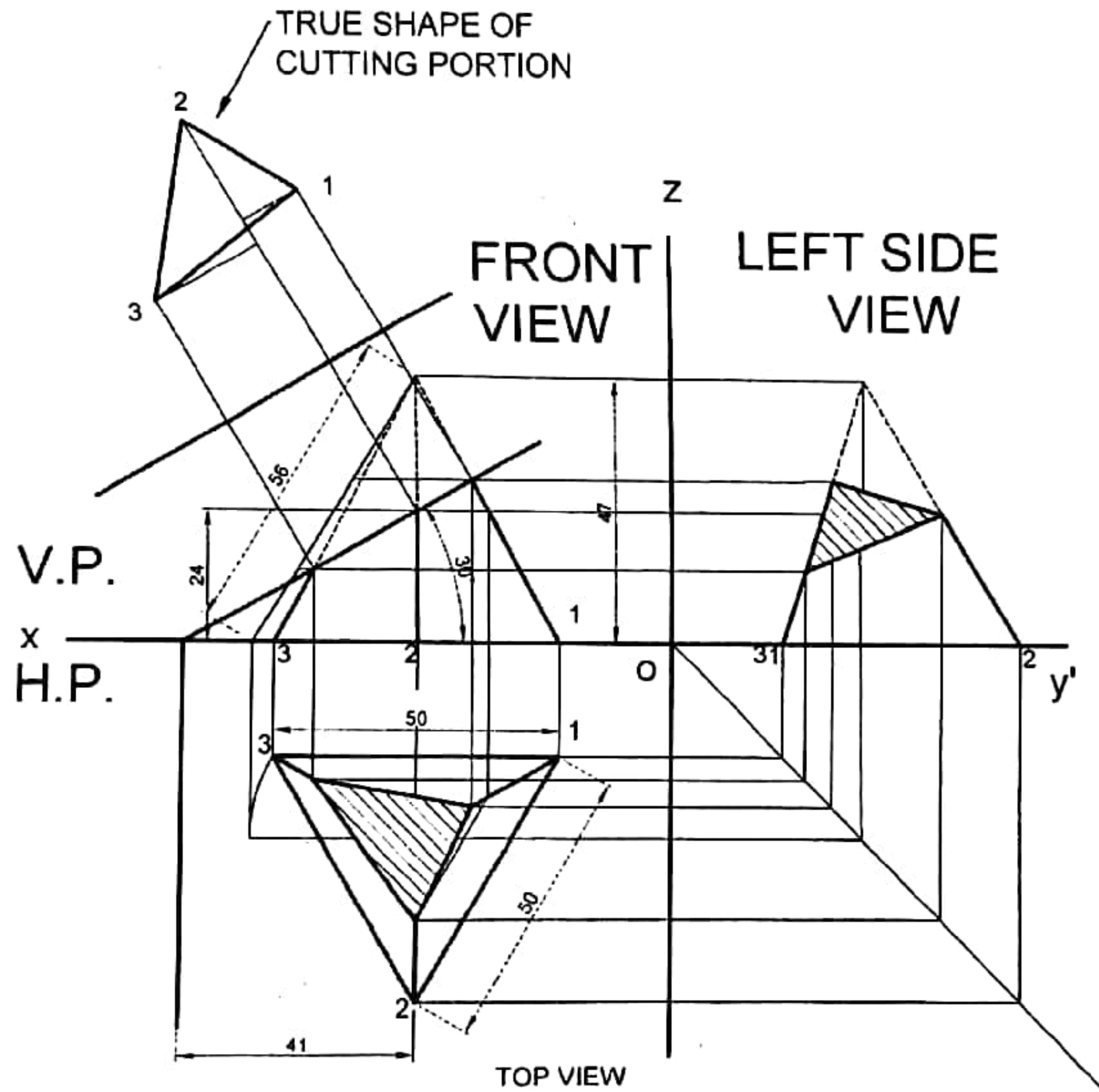

ORTHOGRAPHIC PROJECTION OF TRIANGULAR BASE PYRAMID

SURFACE DEVELOPMENT OF TRIANGULAR BASE PYRAMID.

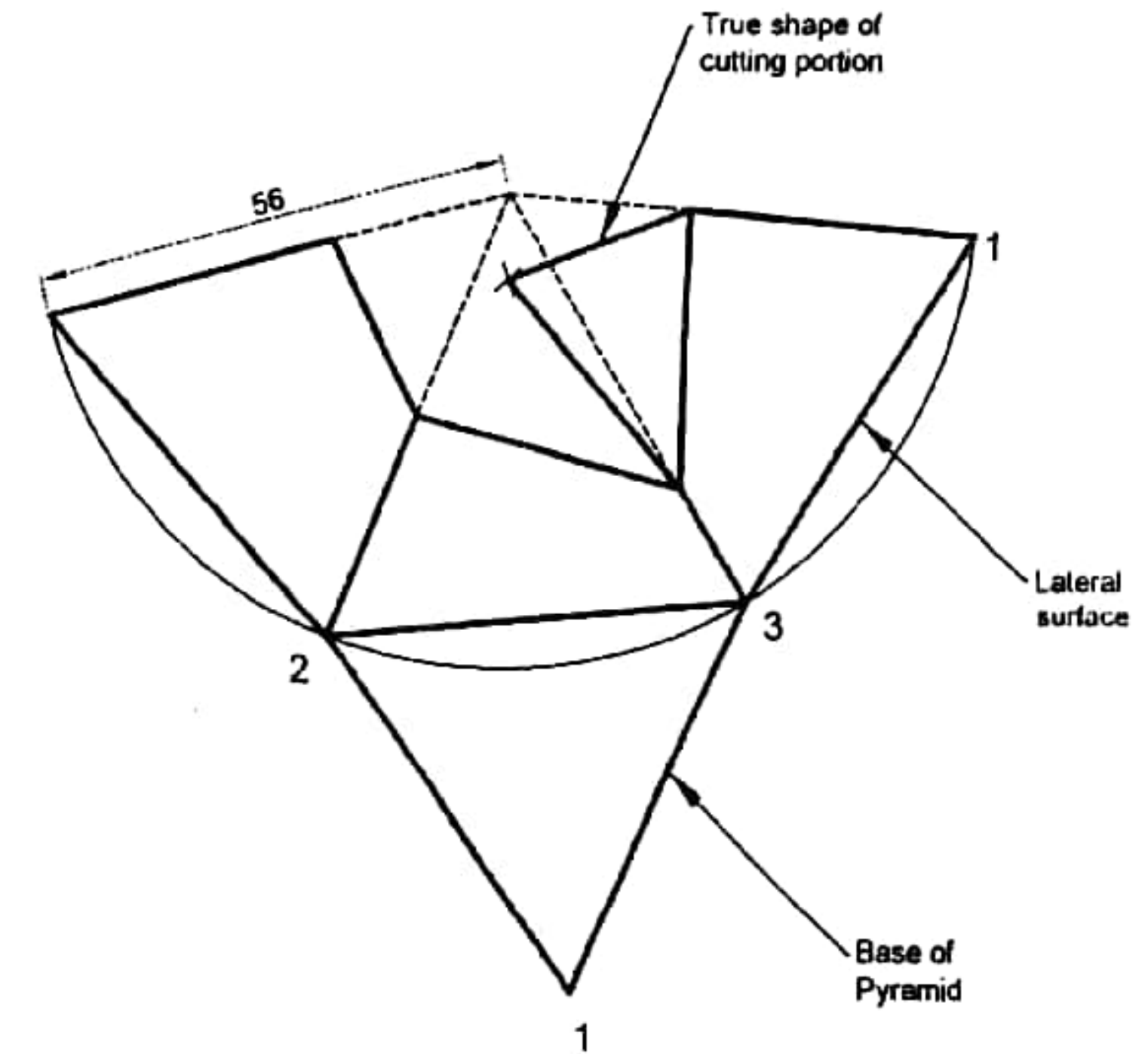

2. A equilateral triangular base pyramid having the edge of 50 mm, and 47 mm high, it is standing on HP by its base, one of the edge of base is parallel to VP, It is cut by a sectional plane which is perpendicular to VP and inclined to HP at 30° passing through the axis at height of 24 mm above base, Now draw the three plane projection with complete surface development with true shape.

TRIBHUVAN UNIVERSITY
INSTITUTE OF ENGINEERING
THAPATHALI CAMPUS
MAITIGHAR, KATHMANDU

SUBJECT
ENGINEERING DRAWING

TITLE
SURFACE DEVELOPMENT OF
GEOMETRICAL SOLIDS
(WITH TRUNCATED),
FINDING TRUE SHAPE

DRAWN BY
NAME
ROLL NO

CHECKED BY
DATE

DATE

SCALE

DRAWING NO

69

TRUE SHAPE OF CUTTING PORTION

SURFACE DEVELOPMENT OF SQUARE BASE PYRAMID.

FRONT VIEW LEFT SIDE VIEW

FRONT VIEW

V.P.

H.P.

TOP VIEW

TRUE SHAPE OF CUTTING PORTION

Lateral surface

Base of Pyramid

1. A square base pyramid of base edge is 33 mm and axial height is 66 mm, it is rested on HP by its base, its two edges of base is equally inclined to VP at 45°, it is cut by a vertical projecting plane which is inclined to HP°, and passing through the axis at the height 33mm from its base, now draw the orthographic projection with whole surface area surface development with true shape.

Draw the above mention drawing in 2:1 scale.

4

TOP VIEW

TRIBUVAN UNIVERSITY INSTITUTE OF ENGINEERING THAPATHALI CAMPUS MAITIGHAR, KATHMANDU	SUBJECT ENGINEERING DRAWING	TITLE SURFACE DEVELOPMENT OF GEOMETRICAL SOLIDS (WITH TRUNCATED). FINDING TRUE SHAPE	DRAWN BY NAME ROLL NO	CHECKED BY DATE	DATE SCALE
	DRAWING NO				70

SURFACE DEVELOPMENT OF SQUARE BASE PYRAMID.

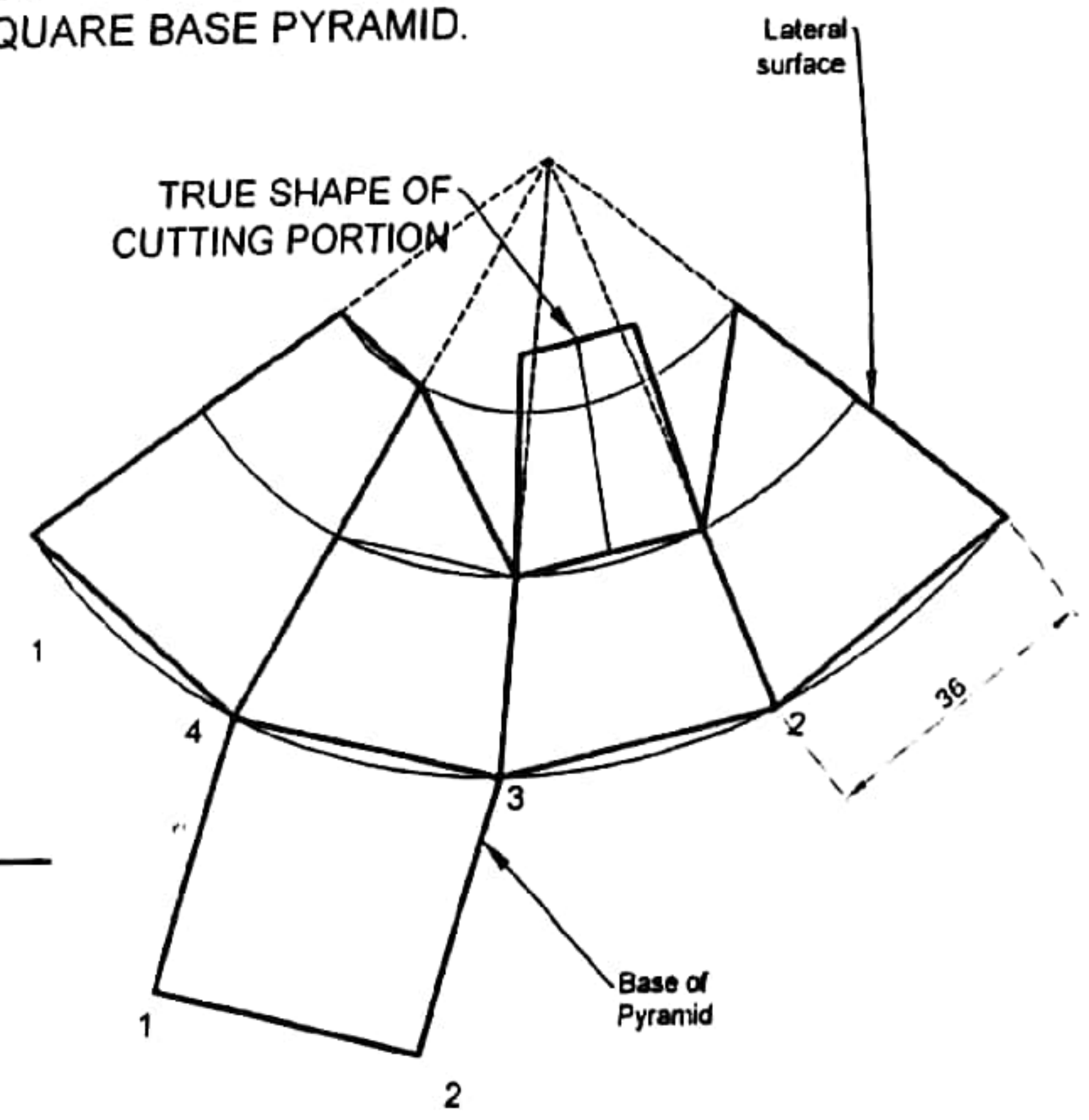
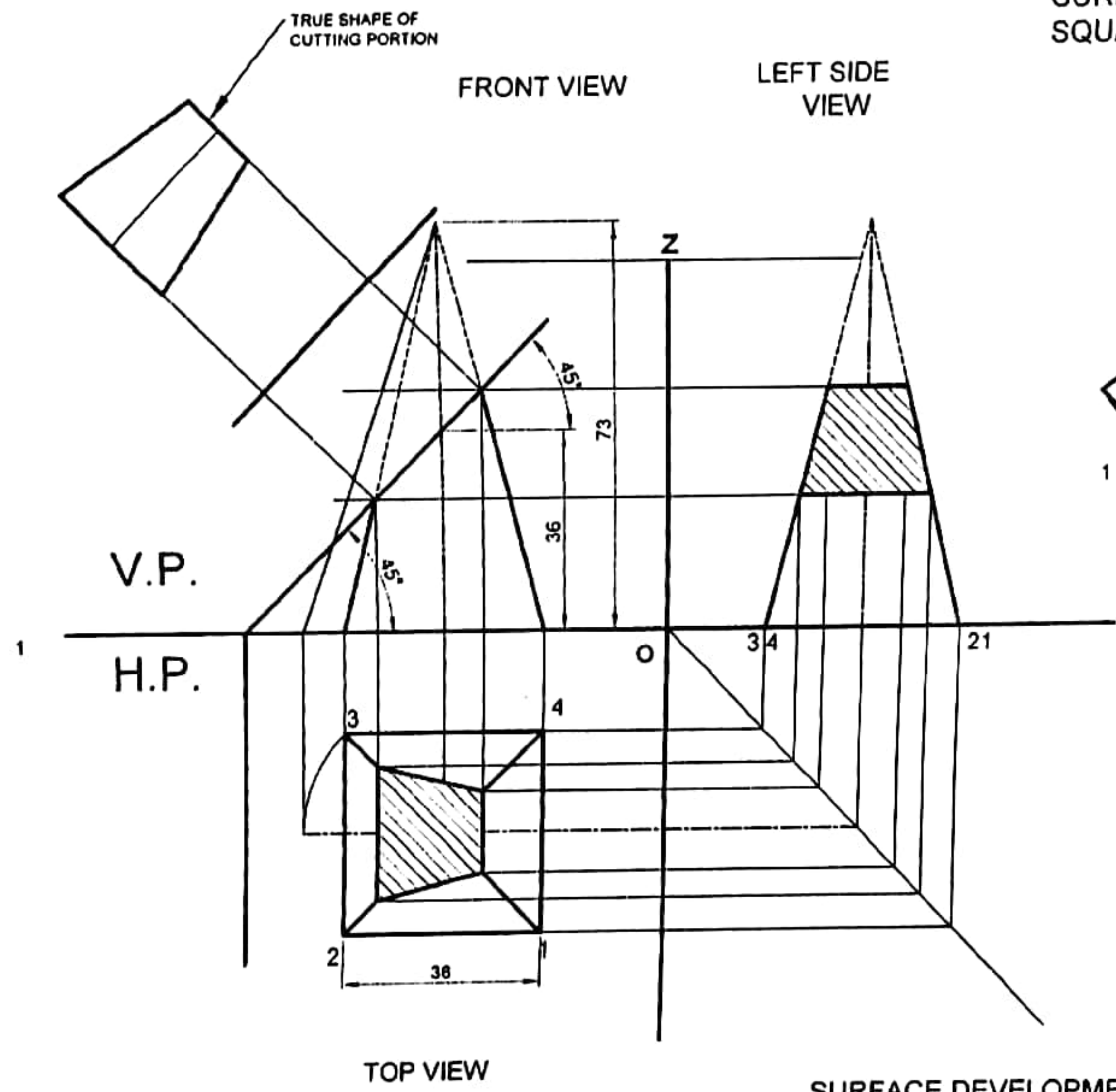

SURFACE DEVELOPMENT OF SQUARE BASE PYRAMID.

Draw the above mention drawing in 2:1 scale.

3. A square base pyramid of base edge is 20 mm and axial height is 36 mm, it is rested on HP by its base, its two edges of base are parallel to VP. It is cut by a vertical projecting plane which is inclined to HP at 45°, and passing through the axis at the height 36mm from its base, now draw the orthographic projection with whole surface area surface development with true shape.

TRIBHUVAN UNIVERSITY INSTITUTE OF ENGINEERING THAPATHALI CAMPUS MAITIGHAR, KATHMANDU	SUBJECT ENGINEERING DRAWING	TITLE SURFACE DEVELOPMENT OF GEOMETRICAL SOLIDS (WITH TRUNCATED). FINDING TRUE SHAPE	DRAWN BY	CHECKED BY	DATE	SCALE
			NAME ROLL NO	DATE	DRAWING NO 71	

SURFACE DEVELOPMENT OF FRUSTUM OF SQUARE BASE PYRAMID

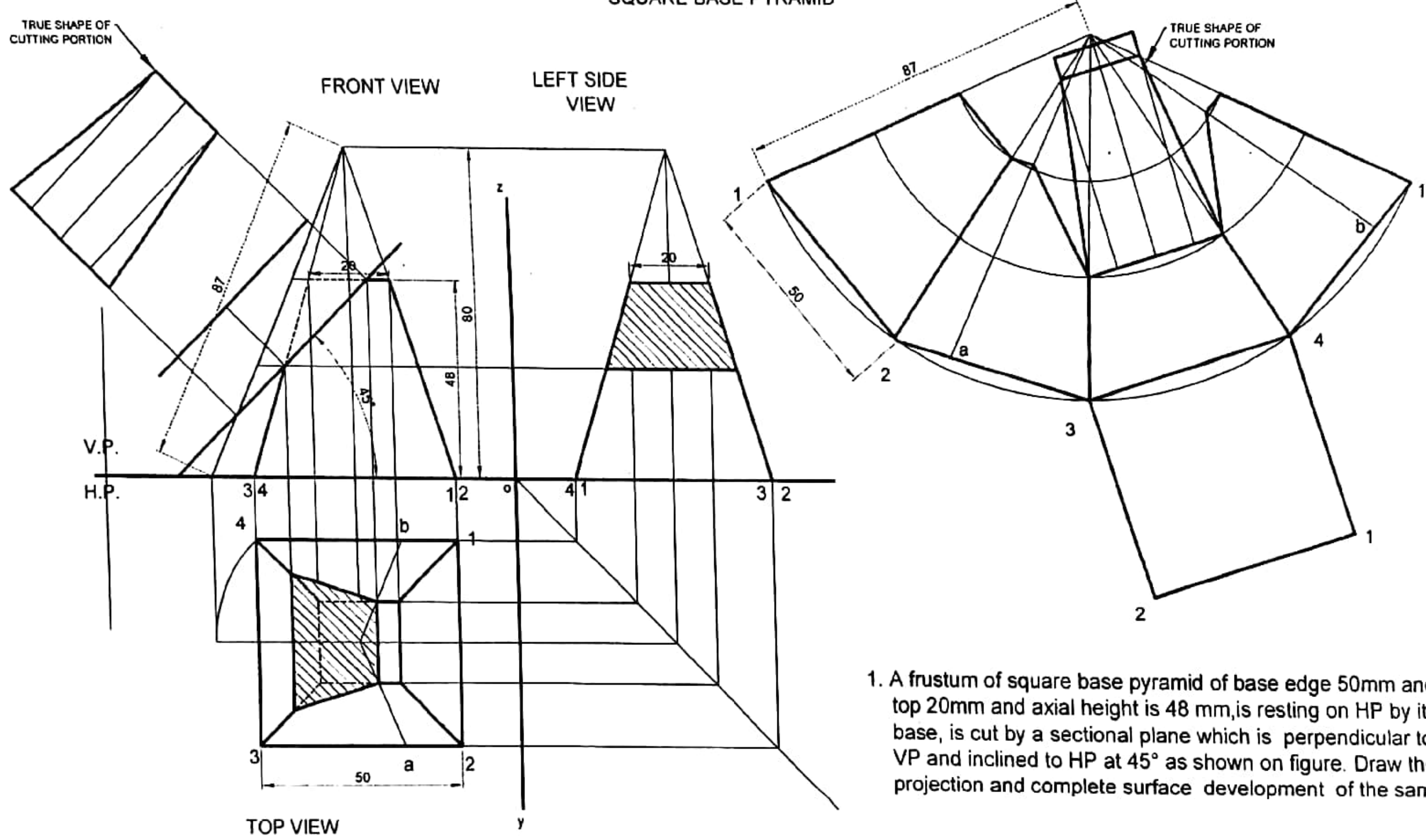

1. A frustum of square base pyramid of base edge 50mm and top 20mm and axial height is 48 mm, is resting on HP by its base, is cut by a sectional plane which is perpendicular to VP and inclined to HP at 45° as shown on figure. Draw the projection and complete surface development of the same.

TRIBHUVAN UNIVERSITY INSTITUTE OF ENGINEERING THAPATHALI CAMPUS MAITIGHAR, KATHMANDU	SUBJECT ENGINEERING DRAWING	TITLE SURFACE DEVELOPMENT OF GEOMETRICAL SOLIDS (WITH TRUNCATED), FINDING TRUE SHAPE	DRAWN BY NAME ROLL NO	CHECKED BY DATE	DATE	SCALE
					DRAWING NO 72	

FRONT VIEW

LEFT SIDE VIEW

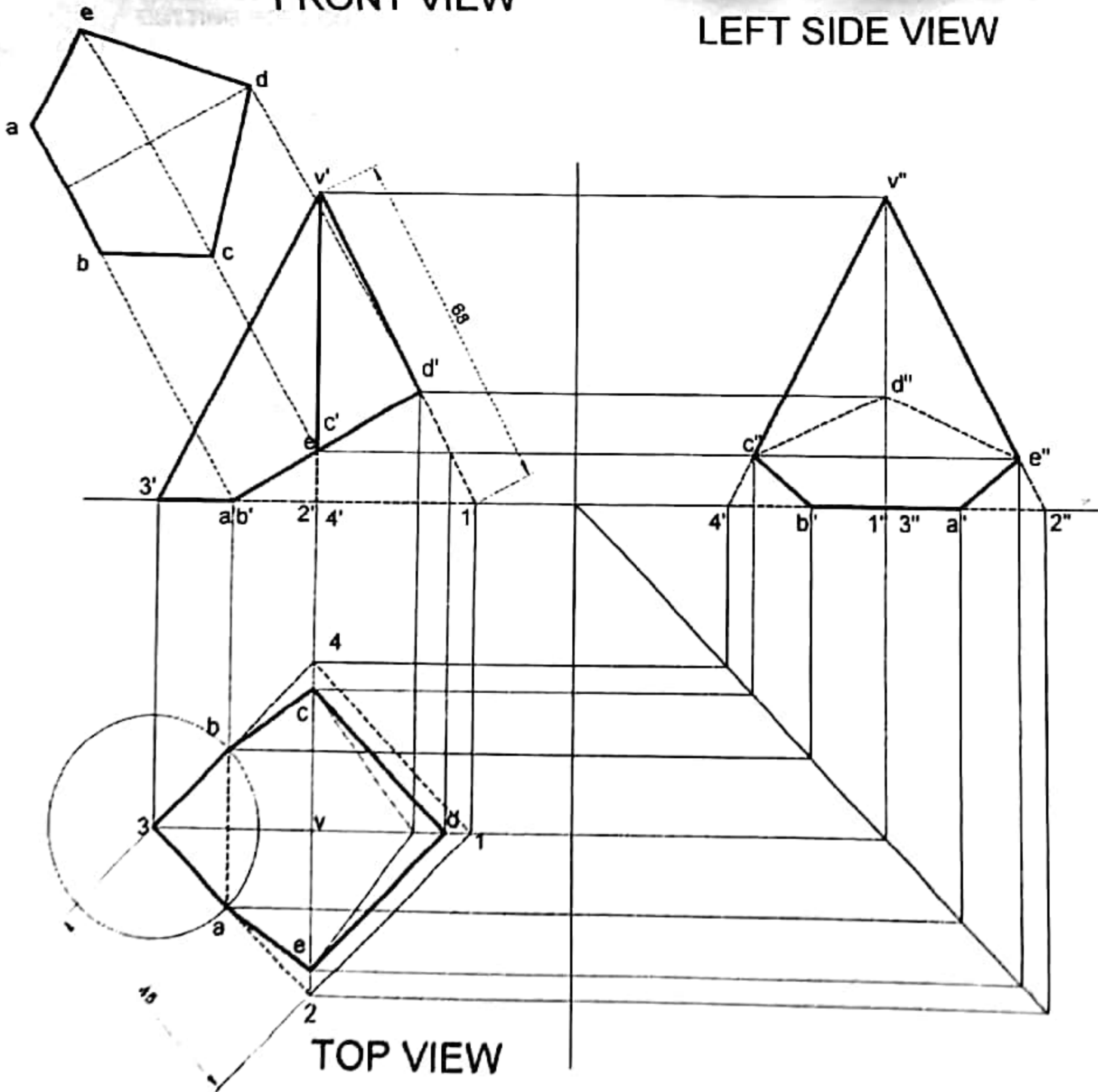

TOP VIEW

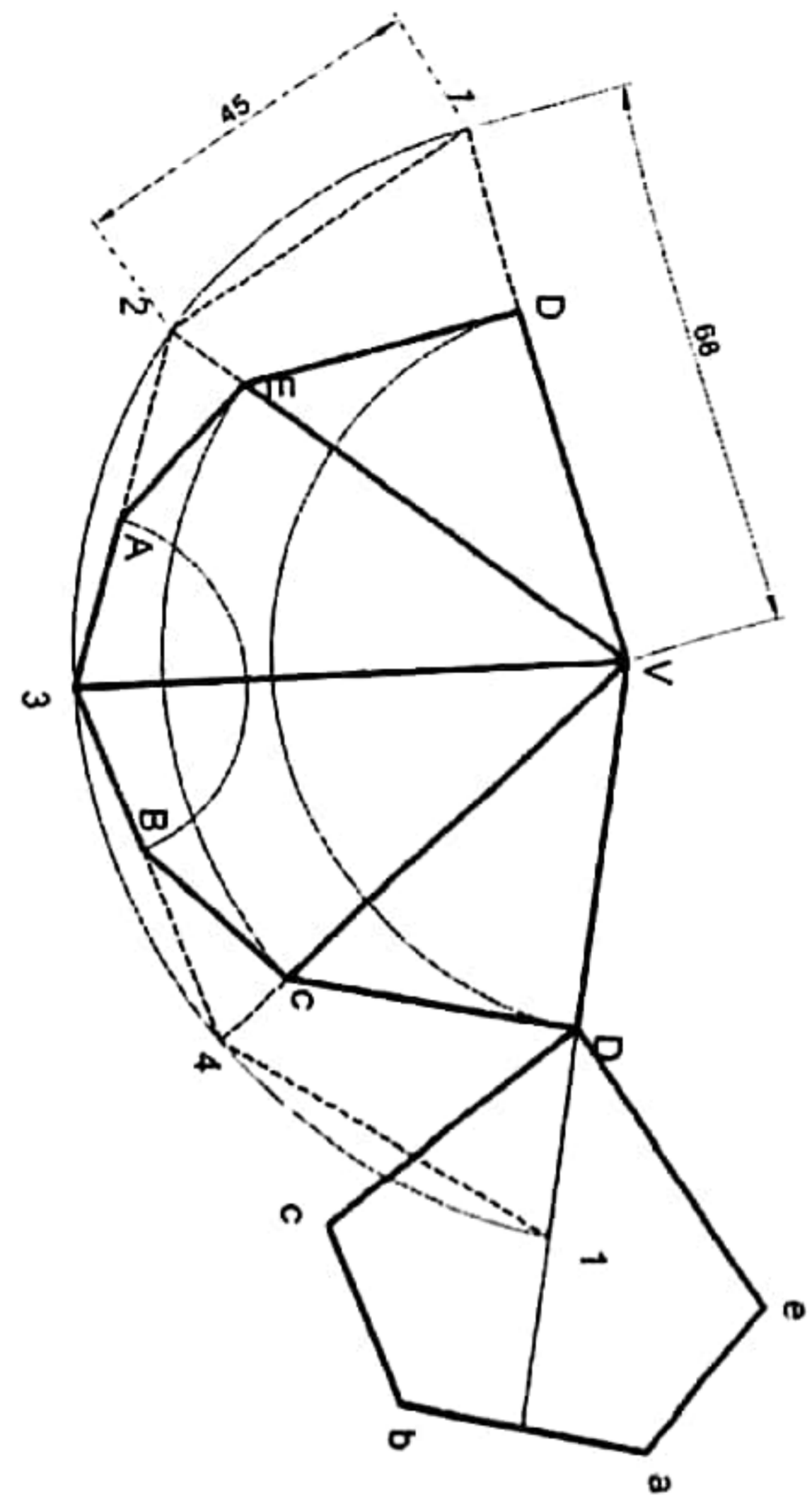

SURFACE DEVELOPMENT OF FRUSTUM OF SQUARE BASE PYRAMID (TRUNCATED)

TRIBHUVAN UNIVERSITY INSTITUTE OF ENGINEERING THAPATHALI CAMPUS MANICHAIR, YATHAMAHA	SUBJECT	TITLE	DRAWN BY	CHECKED BY	DATE	SCALE
	ENGINEERING DRAWING	ASSEMBLE DRAWING	NAME ROLL NO			
				DATE	DRAWING NO 73	

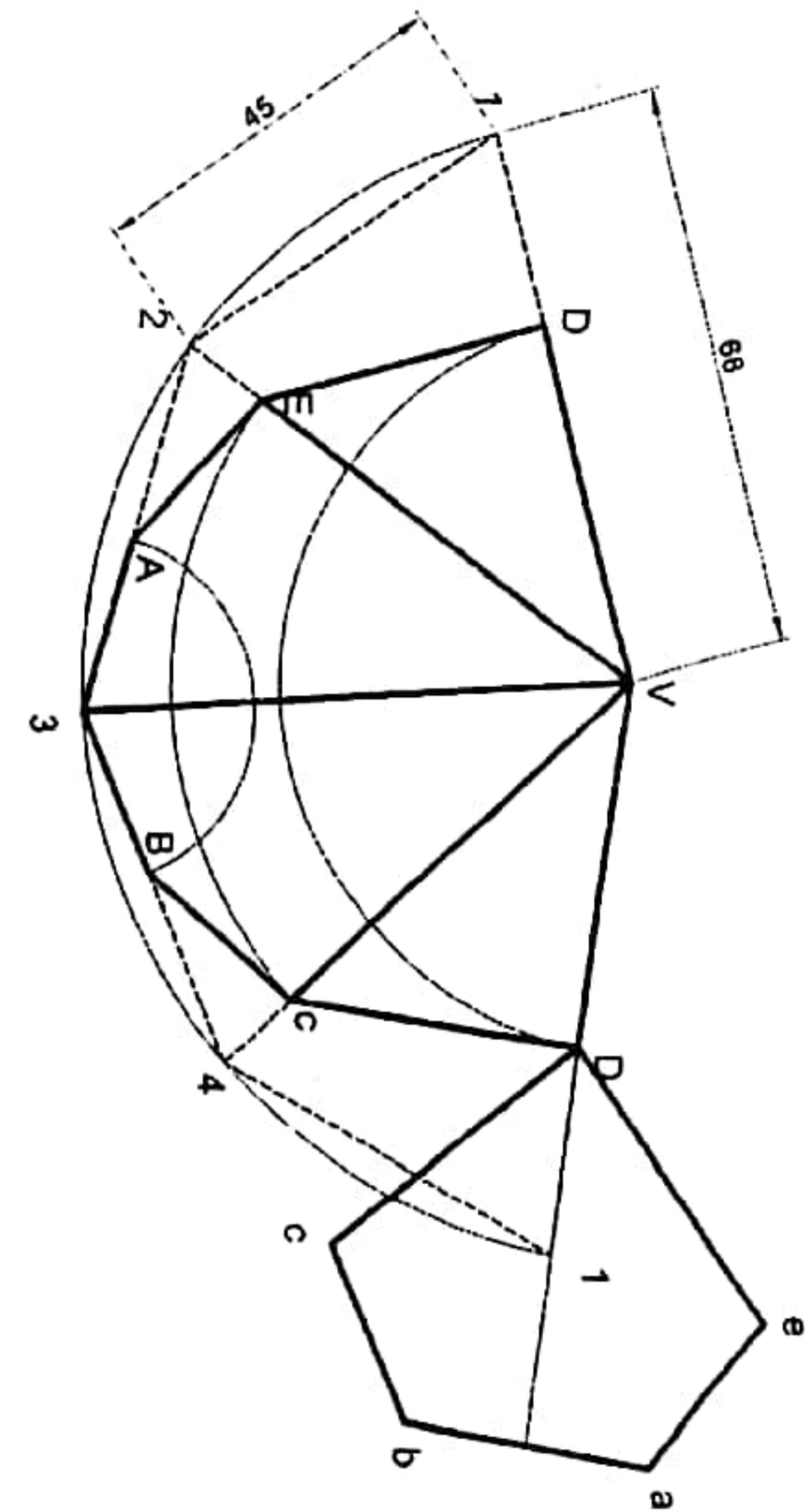
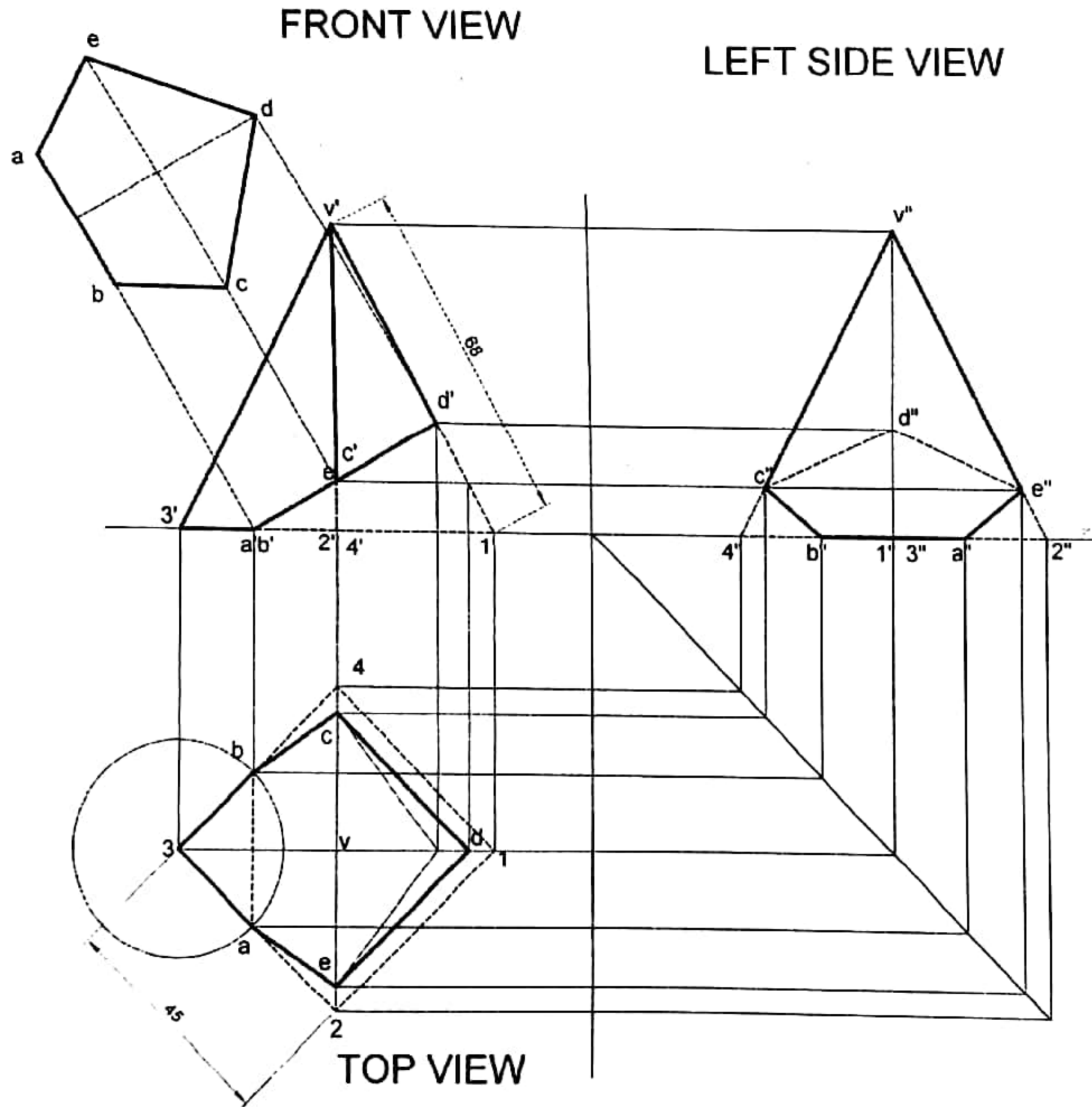

SURFACE DEVELOPMENT OF FRUSTUM OF SQUARE BASE PYRAMID (TRUNCATED)

TRIBHUVAN UNIVERSITY INSTITUTE OF ENGINEERING THAPATHALI CAMPUS MAITIGHAR, KATHMANDU	SUBJECT	TITLE	DRAWN BY	CHECKED BY	DATE	SCALE
	ENGINEERING DRAWING	ASSEMBLE DRAWING	NAME ROLL NO			
				DATE	DRAWING NO 73	

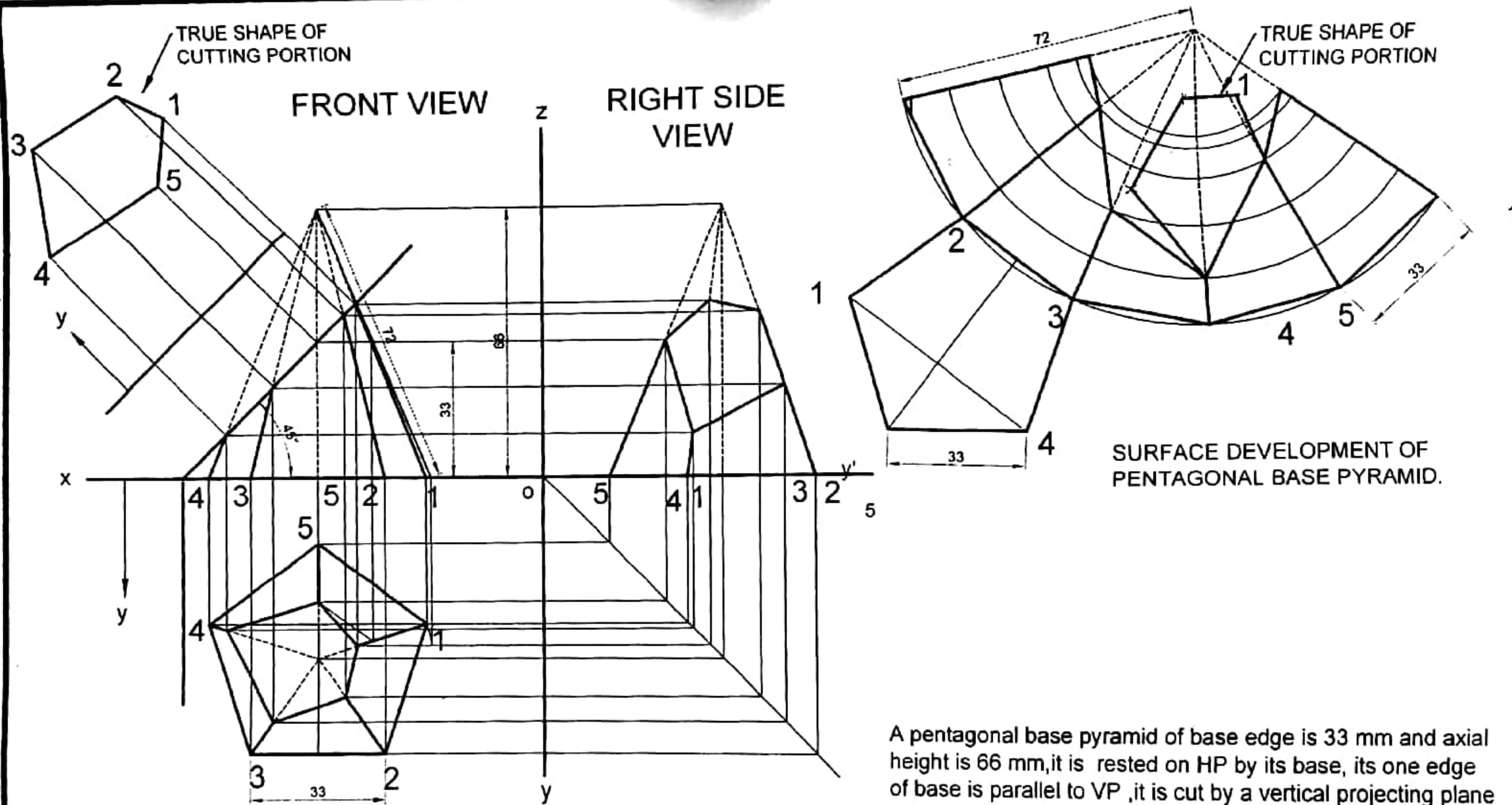

SURFACE DEVELOPMENT OF PENTAGONAL BASE PYRAMID.

A pentagonal base pyramid of base edge is 33 mm and axial height is 66 mm, it is rested on HP by its base, its one edge of base is parallel to VP, it is cut by a vertical projecting plane which is inclined to HP°, and passing through the axis at the height 33mm from its base, now draw the orthographic projection with whole surface area with true shape.

TOP VIEW SURFACE DEVELOPMENT OF PENTAGONAL BASE PYRAMID.

TRIBHUVAN UNIVERSITY INSTITUTE OF ENGINEERING THAPATHALI CAMPUS MAITIGHAR, KATHMANDU	SUBJECT ENGINEERING DRAWING	TITLE SURFACE DEVELOPMENT OF GEOMETRICAL SOLIDS (WITH TRUNCATED). FINDING TRUE SHAPE	DRAWN BY NAME ROLL NO	CHECKED BY DATE	DATE	SCALE
					DRAWING NO	

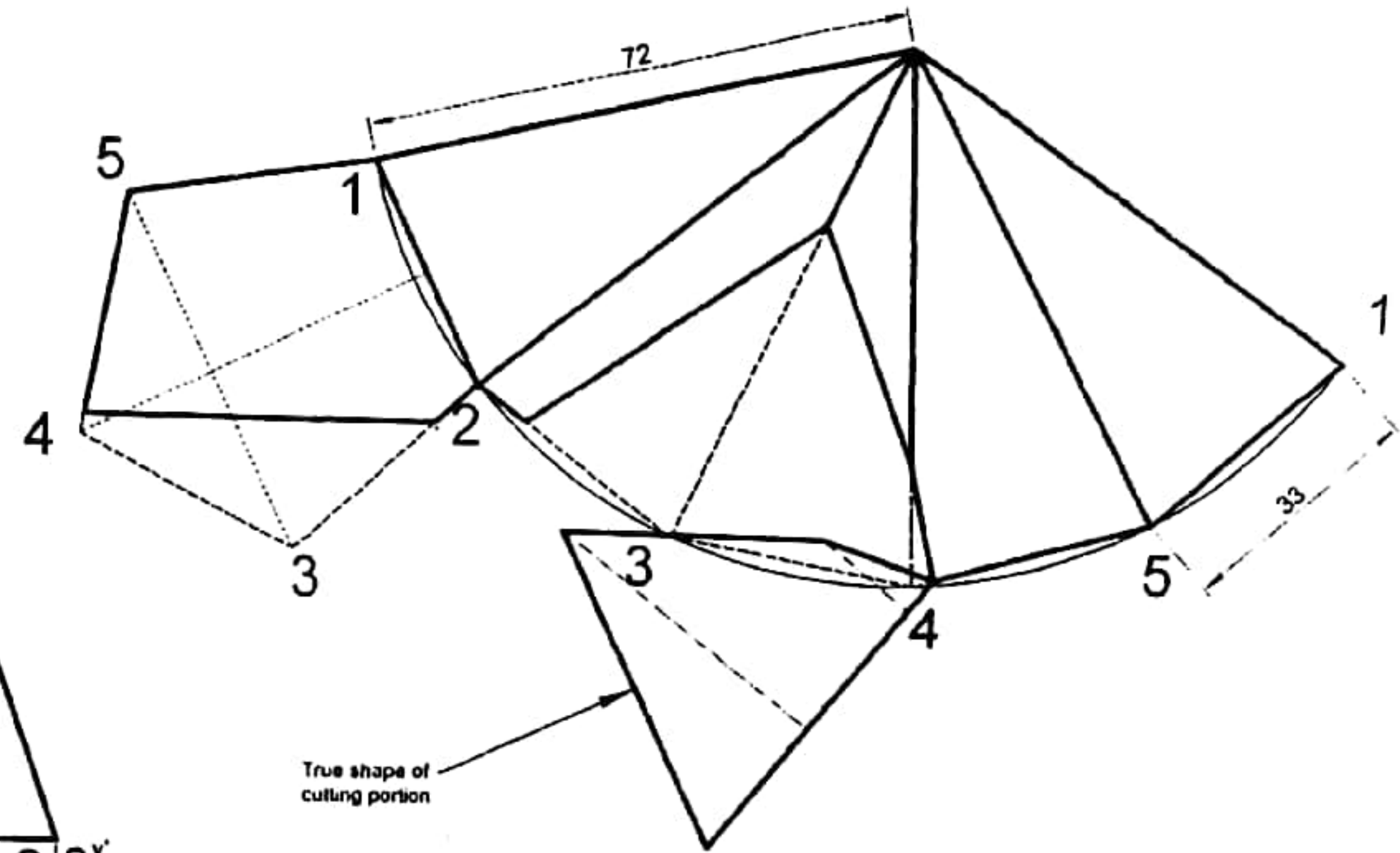
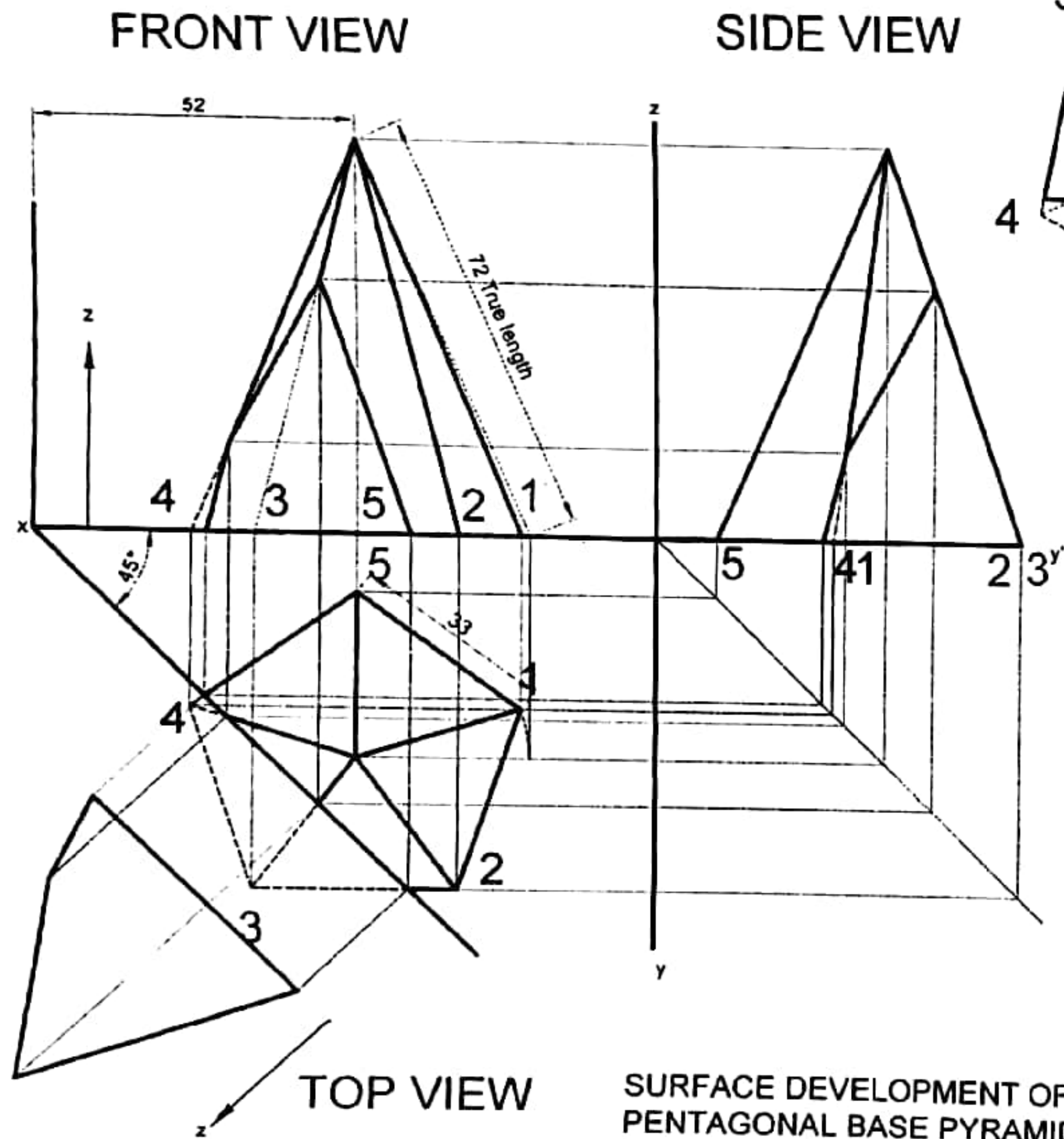

A pentagonal base pyramid of base edge is 33 mm and axial height is 66 mm, it is rested on HP by its base, its one edge of base is parallel to VP, it is cut by a horizontal projecting plane which is inclined to VP at 45°, as shown on figure. Now you are asked to draw three plane projection and complete the whole surface development with true shape.

TRENKUNJAH UNIVERSITY INSTITUTE OF ENGINEERING THAPATHALI CAMPUS MAITICHAH KATHMANDU	SUBJECT ENGINEERING DRAWING	TITLE SURFACE DEVELOPMENT OF GEOMETRICAL SOLIDS (WITH TRUNCATED). FINDING TRUE SHAPE	DRAWN BY NAME ROLL NO	CHECKED BY	DATE	SCALE
					DATE	DRAWING NO 75

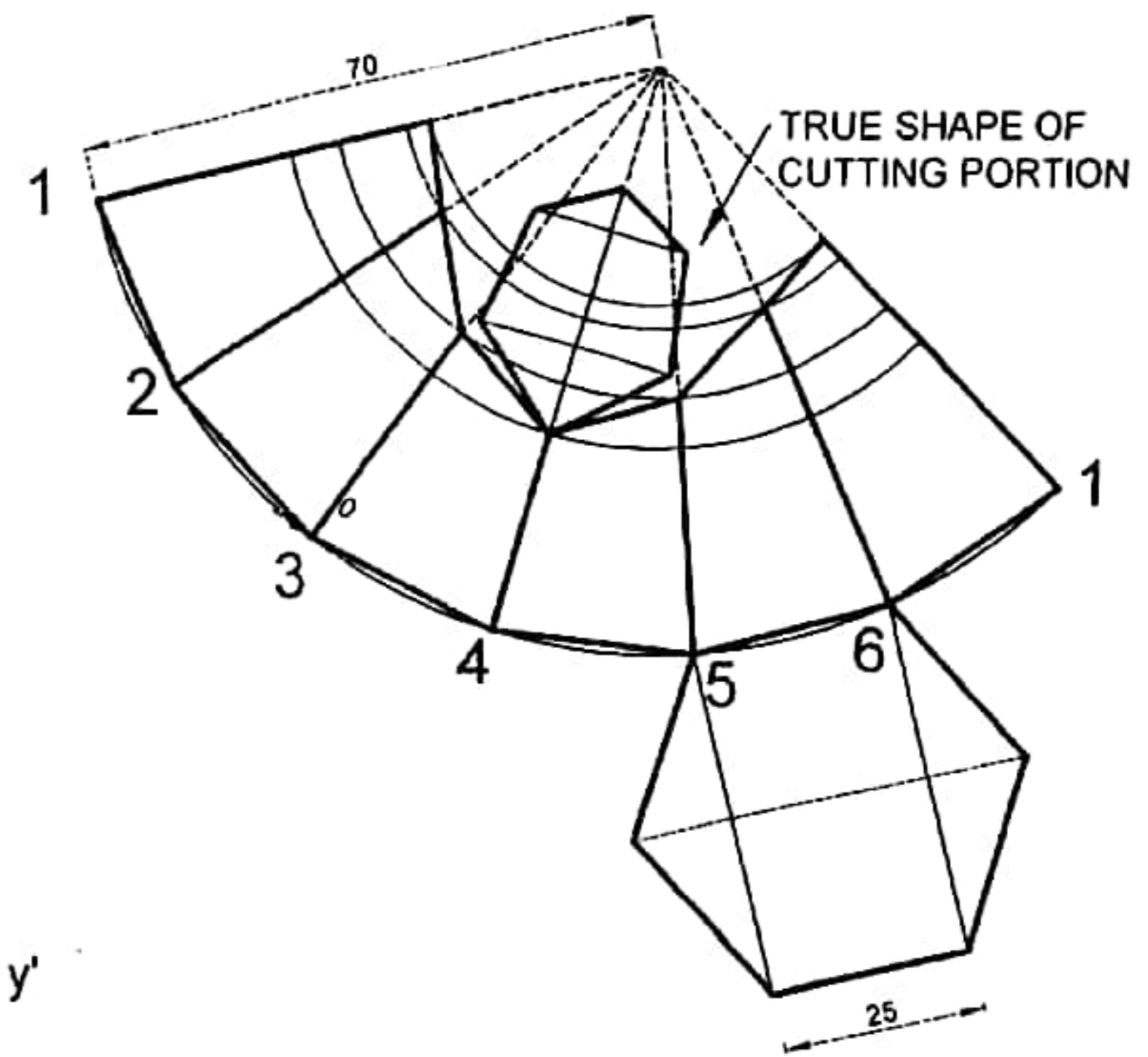
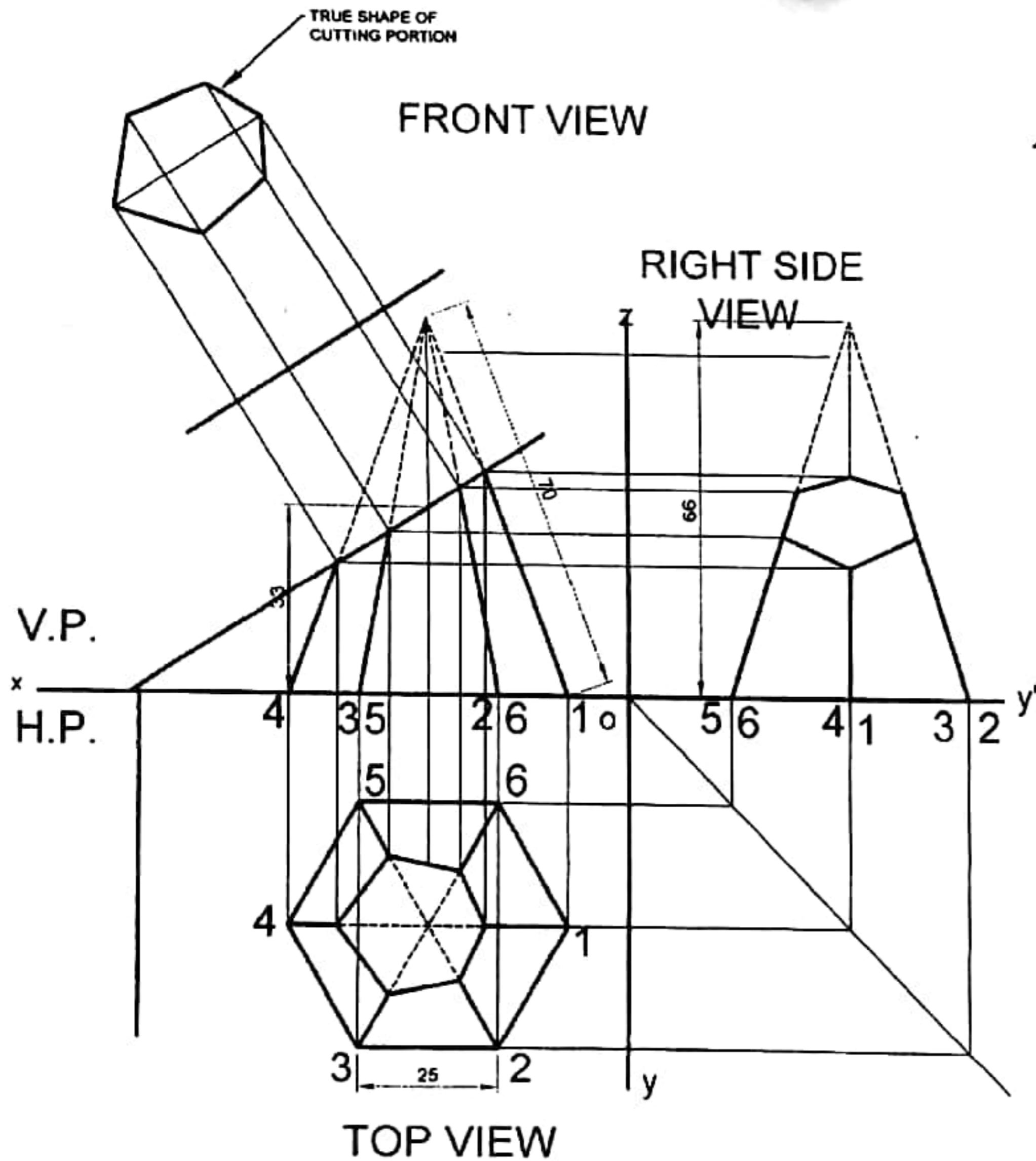

SURFACE DEVELOPMENT OF HEXAGONAL BASE PYRAMID.

A hexagonal base pyramid of base edge is 25 mm and axial height is 66 mm, it is rested on HP by its base, its two edges of base is parallel to VP, it is cut by a vertical projecting plane which is inclined to HP° , and passing through the axis at the height 33mm from its base, now draw the orthographic projection with whole surface area with true shape.

TRIBHUVAN UNIVERSITY INSTITUTE OF ENGINEERING THAPATHALI CAMPUS MAITIGHAR, KATHMANDU	SUBJECT ENGINEERING DRAWING	TITLE SURFACE DEVELOPMENT OF GEOMETRICAL SOLIDS (WITH TRUNCATED), FINDING TRUE SHAPE	DRAWN BY NAME ROLL NO	CHECKED BY	DATE	SCALE
					DATE	DRAWING NO 76

SURFACE DEVELOPMENT OF
HEXAGONAL BASE PYRAMID.

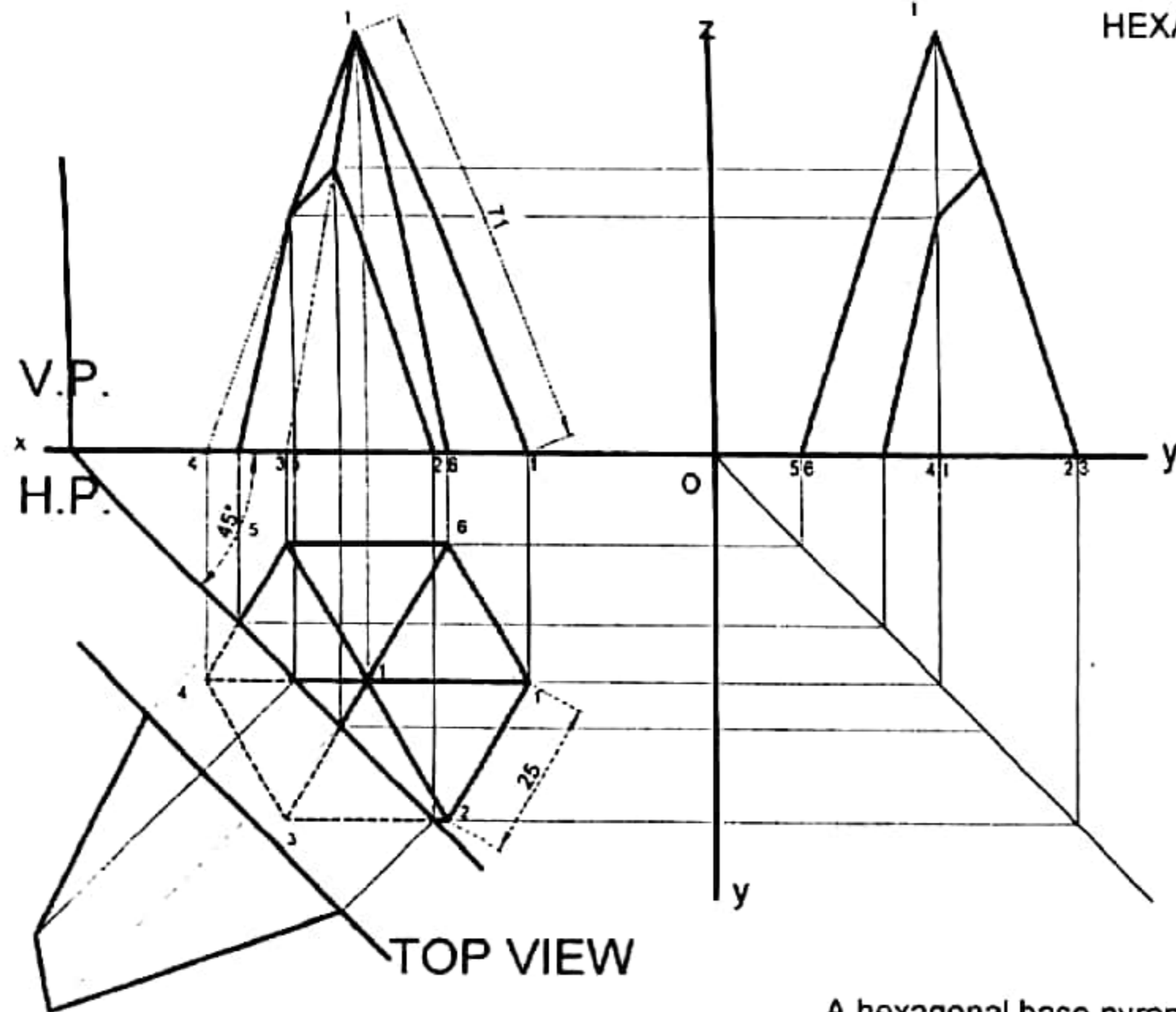

TOP VIEW

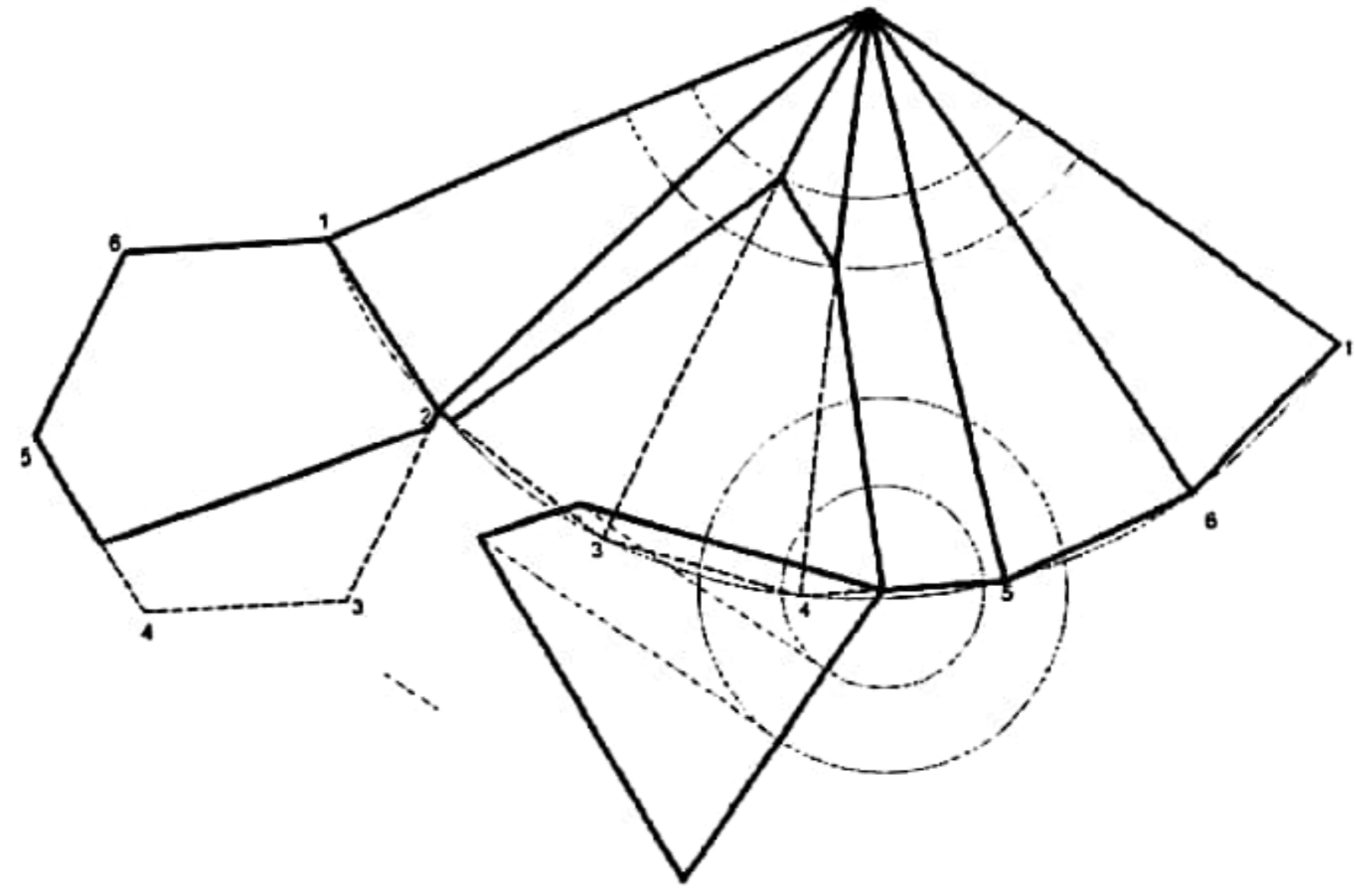

SURFACE DEVELOPMENT OF
HEXAGONAL BASE PYRAMID.

A hexagonal base pyramid of base edge is 25mm and axial height is 66 mm, it is rested on HP by its base, its two edges of base is parallel to VP, it is cut by a horizontal projecting plane which is inclined to VP° at 45° as shown on figure draw the orthographic projection with whole surface development with true shape.

TRIBHUVAN UNIVERSITY INSTITUTE OF ENGINEERING THAPATHALI CAMPUS MAITIGHAR, KATHMANDU	SUBJECT ENGINEERING DRAWING	TITLE SURFACE DEVELOPMENT OF GEOMETRICAL SOLIDS (WITH TRUNCATED), FINDING TRUE SHAPE	DRAWN BY NAME ROLL NO	CHECKED BY DATE	DATE	SCALE
					DRAWING NO 77	

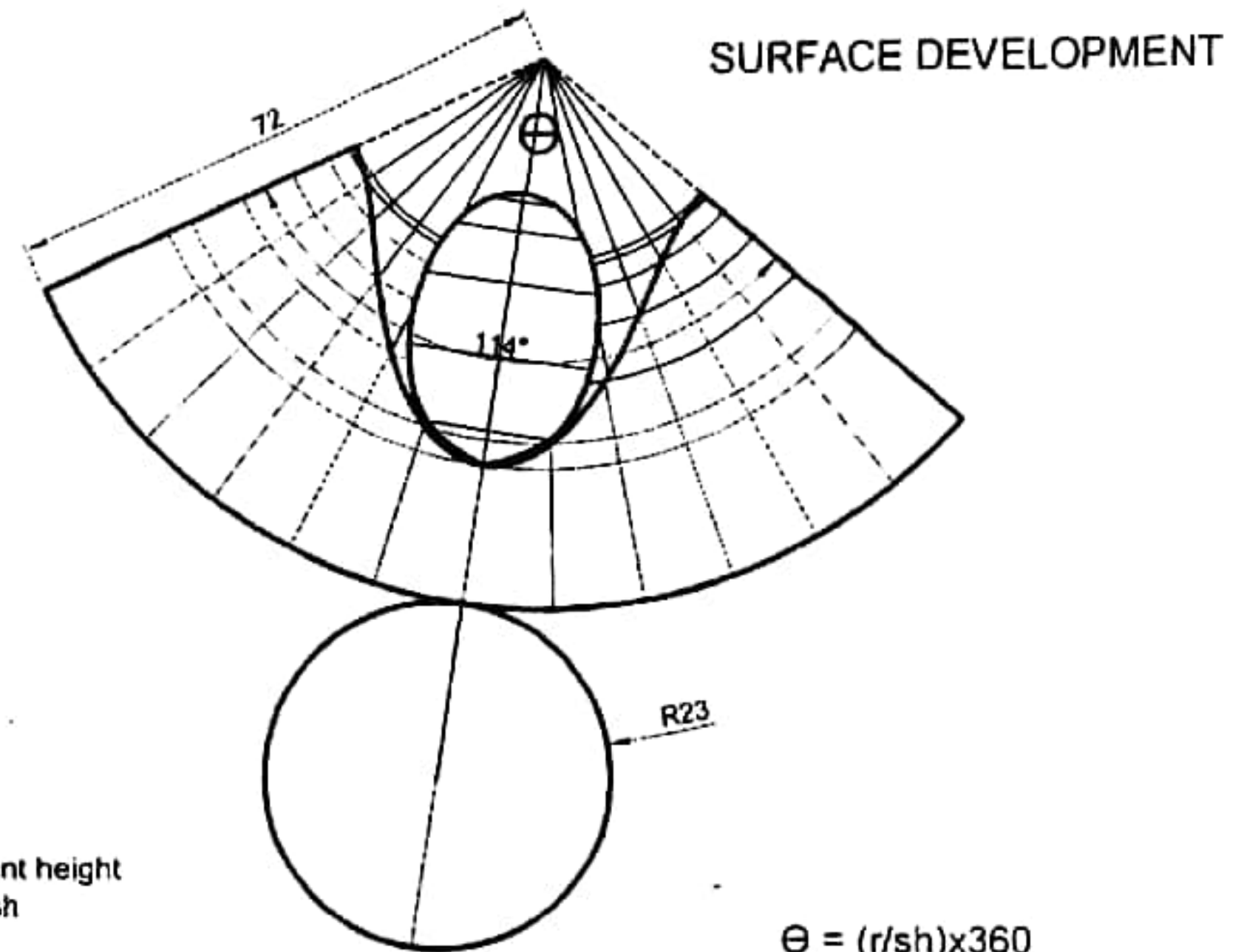
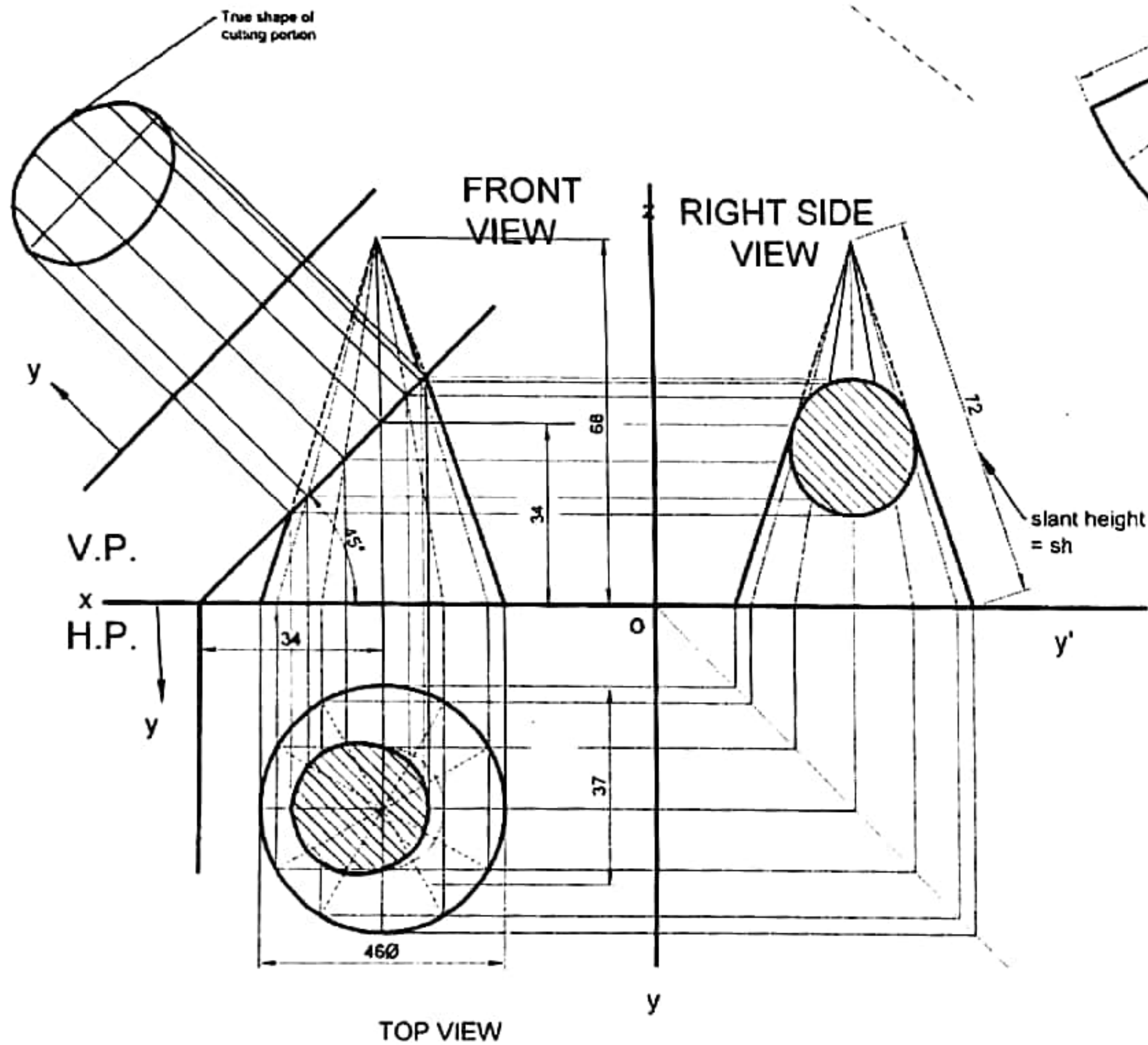

$$\begin{aligned} \Theta &= (r/sh) \times 360 \\ &= (23/72) \times 360 \\ &= 115^\circ (\text{approximate}) \end{aligned}$$

1. A cone of 46mm diameter and axial height of 68 mm is rest on HP by its base on HP . A sectional plane which is perpendicular to VP and inclined to HP at 45° passing through the axis at the 34 mm above base. Draw the projection with true shape and complete surface area with true shape of cone.

SURFACE DEVELOPMENT OF CONE

SURFACE DEVELOPMENT OF SIMPLE (UNCUT STATE AND TRUNCATED) CONE

TRIBHUVAN UNIVERSITY INSTITUTE OF ENGINEERING THAPATHALI CAMPUS MAITIGHAR, KATHMANDU	SUBJECT ENGINEERING DRAWING	TITLE SURFACE DEVELOPMENT OF GEOMETRICAL SOLIDS (WITH TRUNCATED). FINDING TRUE SHAPE	DRAWN BY NAME ROLL NO	CHECKED BY DATE	DATE	SCALE
					DRAWING NO	

SURFACE DEVELOPMENT

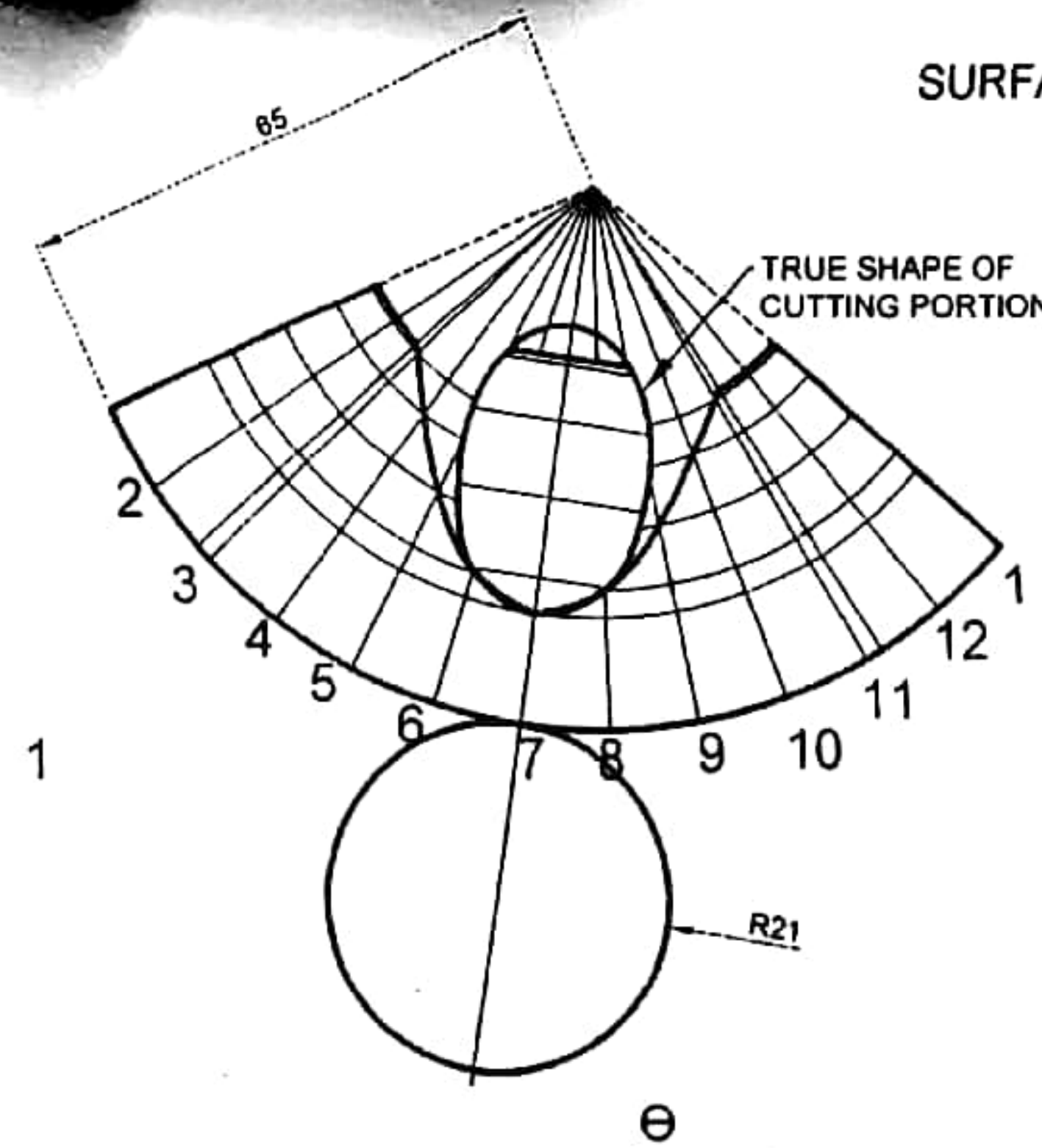
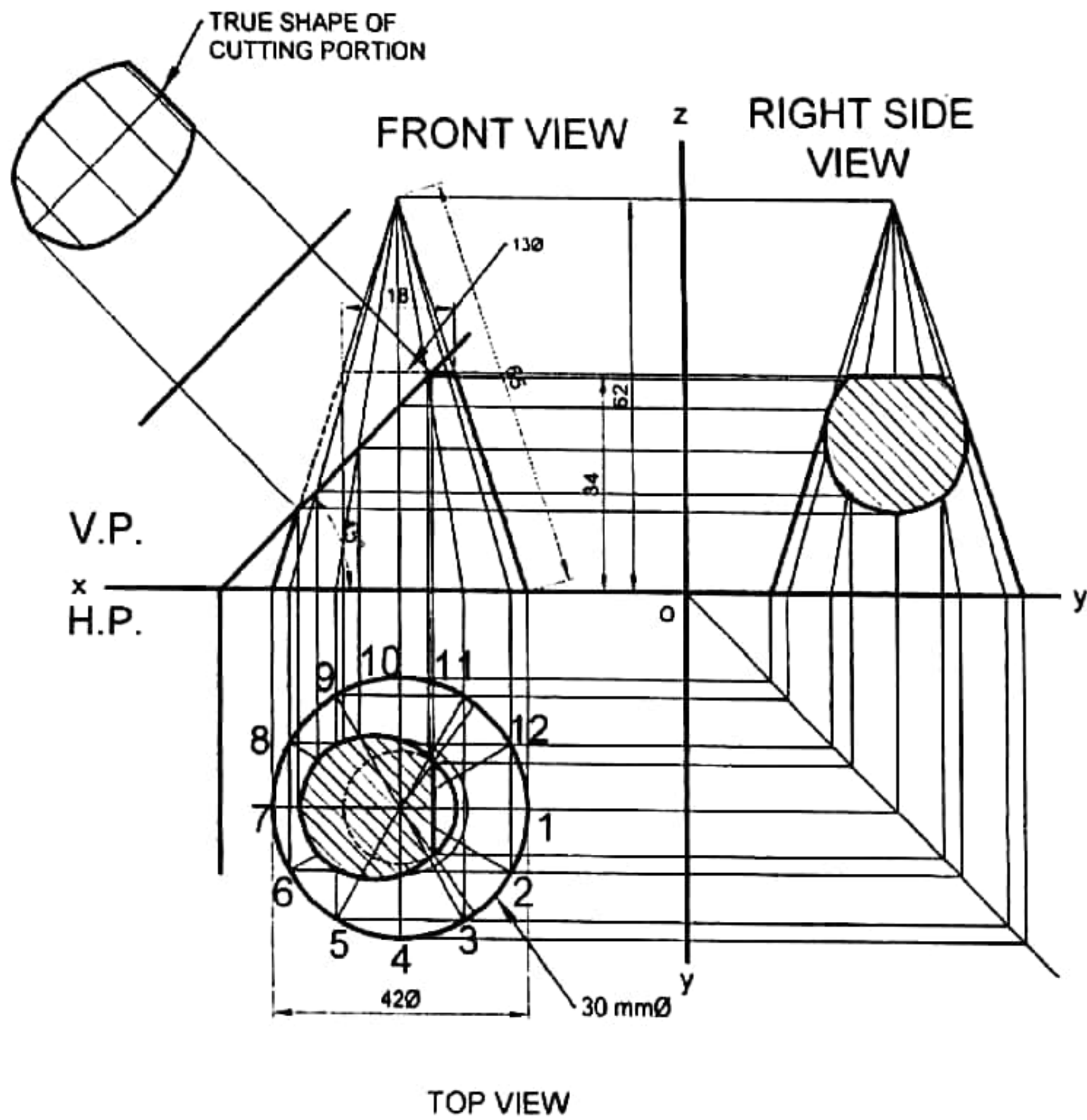

2. A frustum of cone of base 30mmØ and top 13mmØ and axial height is 25 mm, is cut by a sectional which is perpendicular to VP and inclined to HP at 45° as shown on figure. Draw the projection and complete surface development of the same.

SURFACE DEVELOPMENT OF SIMPLE (UNCUT STATE AND TRUNCATED) CONE

TRIBHUVAN UNIVERSITY INSTITUTE OF ENGINEERING THAPATHALI CAMPUS MAITIGHAR, KATHMANDU	SUBJECT ENGINEERING DRAWING	TITLE SURFACE DEVELOPMENT OF GEOMETRICAL SOLIDS (WITH TRUNCATED), FINDING TRUE SHAPE	DRAWN BY NAME ROLL NO	CHECKED BY	DATE	SCALE
				DATE	DRAWING NO 79	

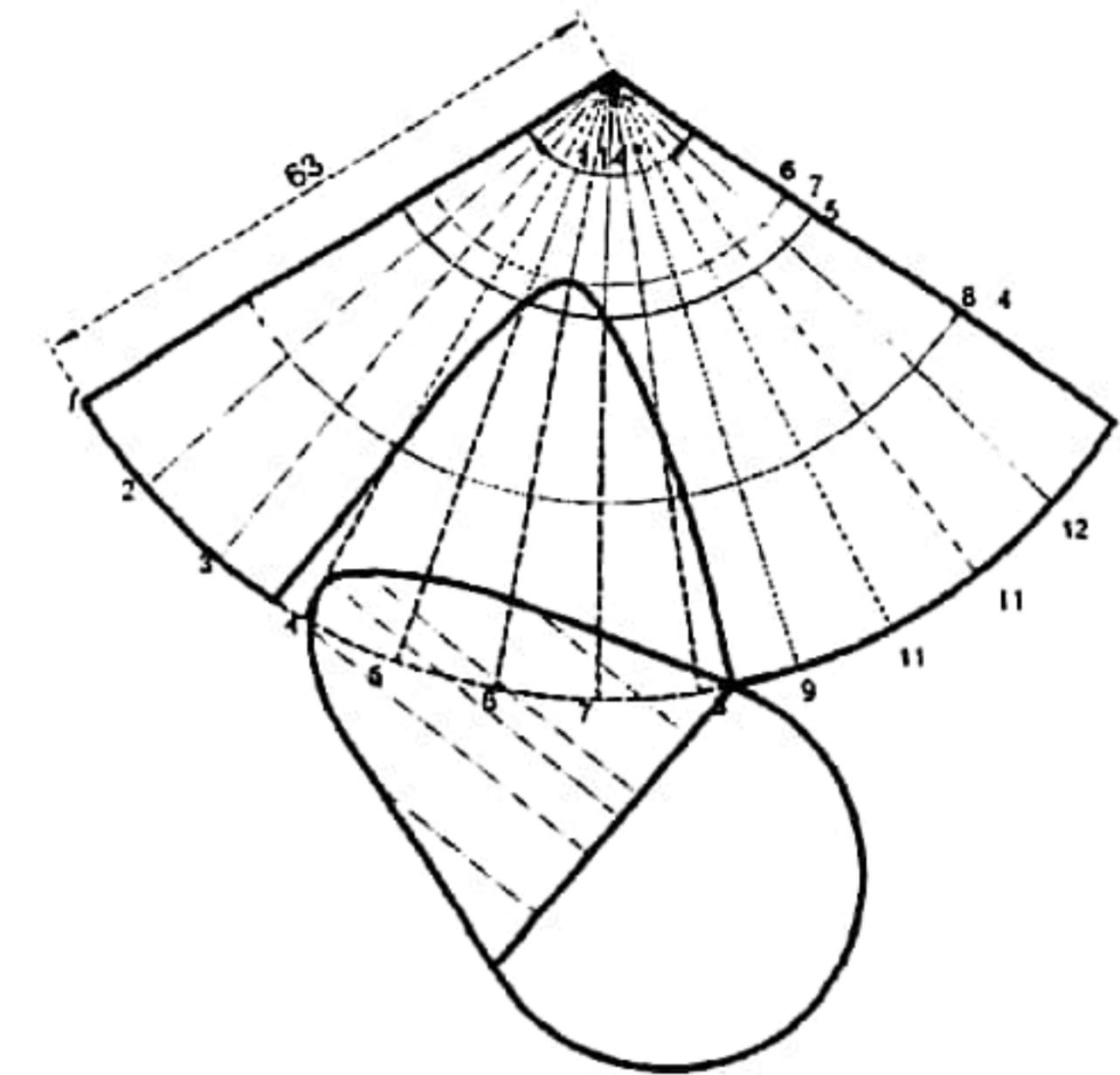
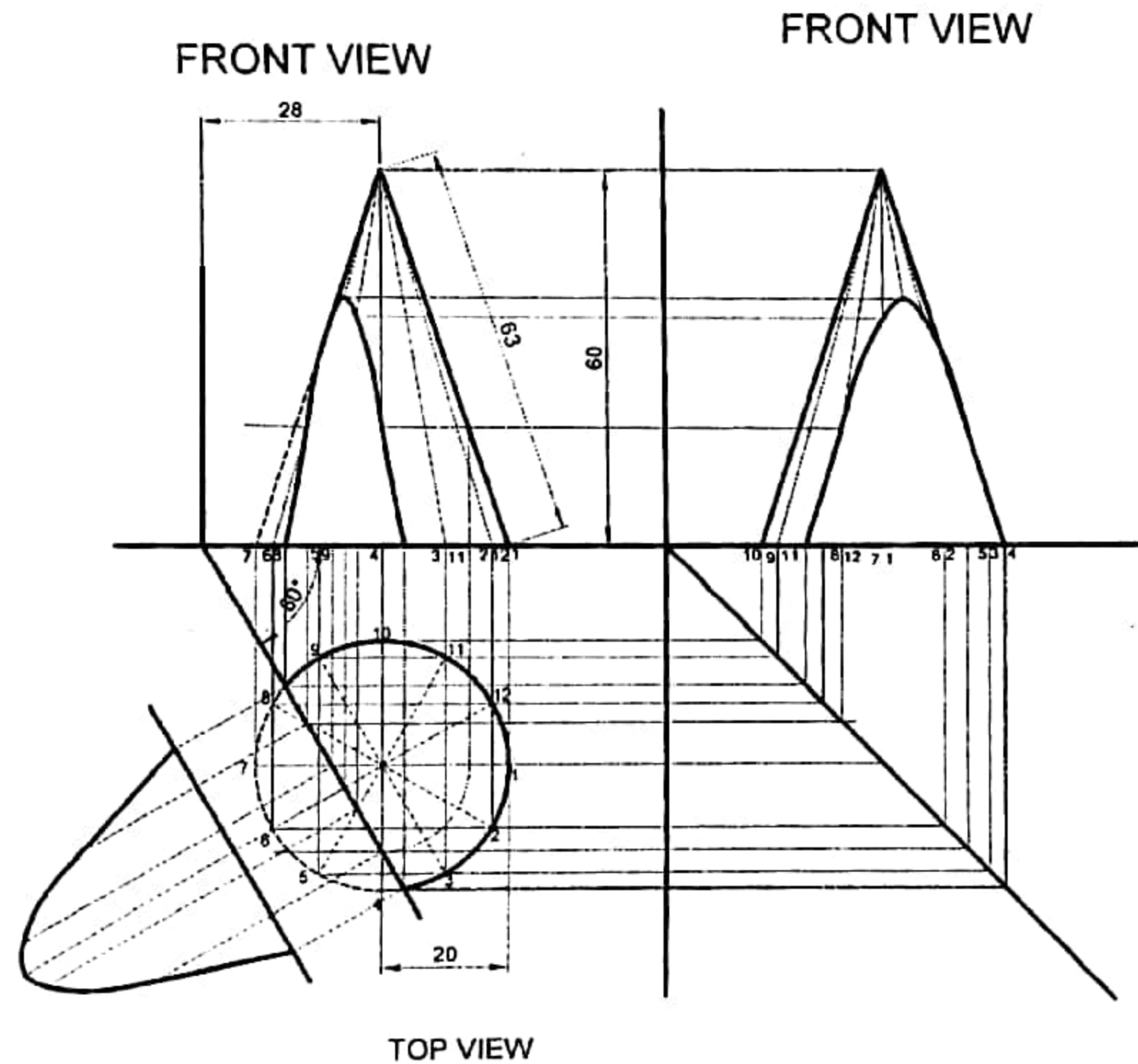

$$\begin{aligned} \Theta &= (r/sh) \times 360 \\ &= (20/63) \times 360 \\ &= 114^\circ (\text{approximate}) \end{aligned}$$

2. A cone of base 40 mm \varnothing and axial height is 60 mm, is cut by a horizontal projecting plane which is inclined to VP at 60° as shown on figure. Draw the projection and complete surface development of the same.

SURFACE DEVELOPMENT OF SIMPLE (UNCUT STATE AND TRUNCATED) CONE

TRIBHUVAN UNIVERSITY INSTITUTE OF ENGINEERING THAPATHALI CAMPUS MAITIGHAR, KATHMANDU	SUBJECT ENGINEERING DRAWING	TITLE SURFACE DEVELOPMENT OF GEOMETRICAL SOLIDS (WITH TRUNCATED). FINDING TRUE SHAPE	DRAWN BY NAME ROLL NO	CHECKED BY DATE	DATE	SCALE
					DRAWING NO 80	

1. Complete the lateral surface of a oblique cone which figure is given here.

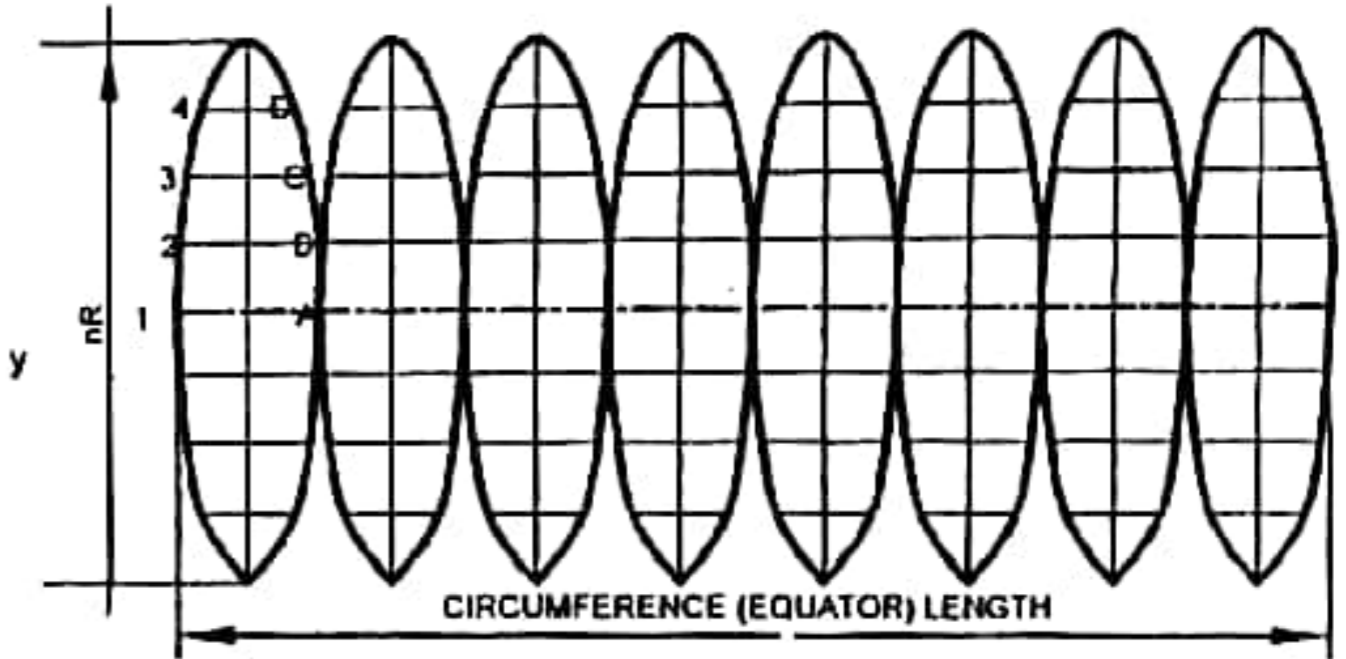
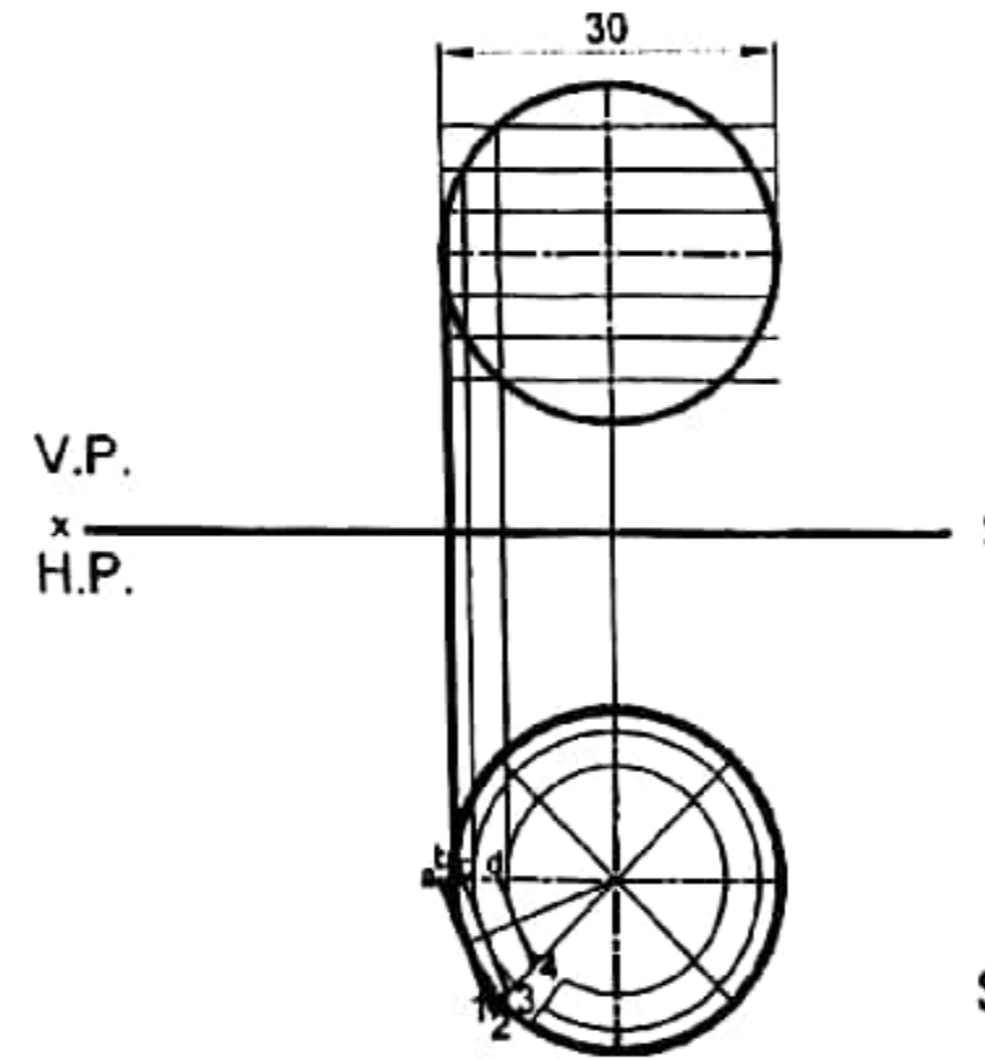
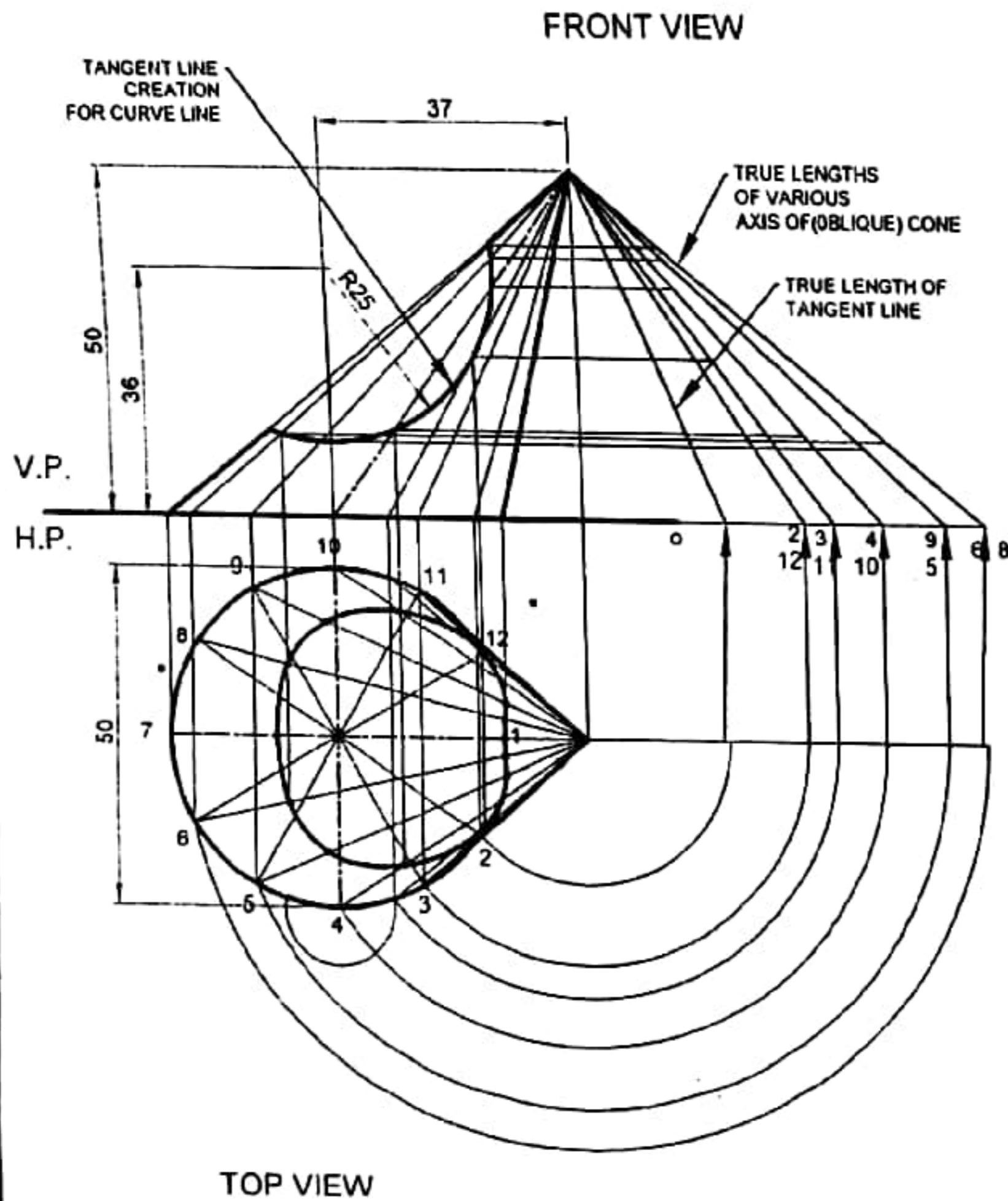

SURFACE DEVELOPMENT OF SPHERE (GORE'S METHOD)

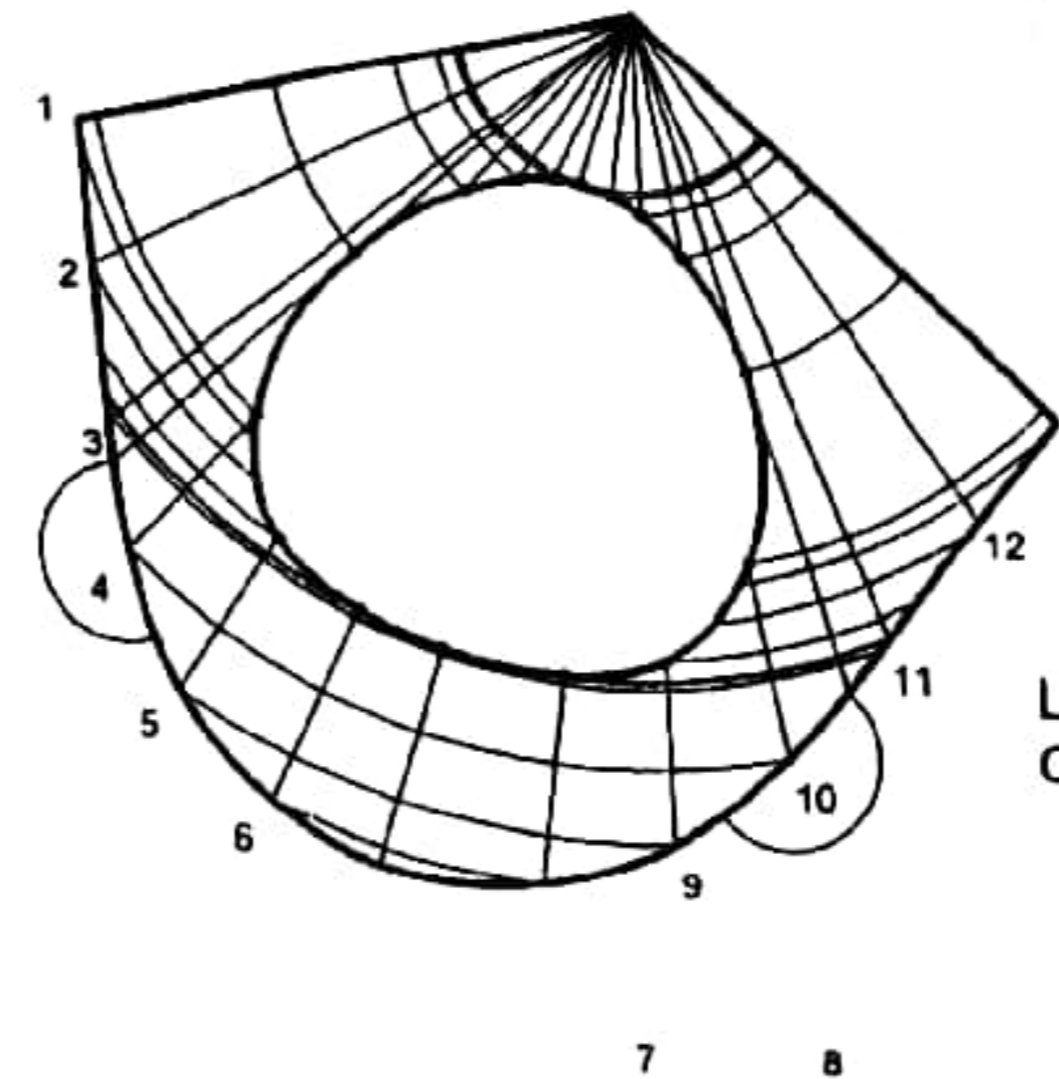

LATERAL SURFACE DEVELOPMENT OF OBLIQUE CONE AS GIVEN.

DRAW THE LATERAL SURFACE DEVELOPMENT OF OBLIQUE CONE AND IT IS CUT BY A CERVICAL PLANE AS SHOWN ON GIVEN FIGURE ABOVE.

TRIBHUVAN UNIVERSITY INSTITUTE OF ENGINEERING THAPATHALI CAMPUS MAITIGHAR, KATHMANDU	SUBJECT ENGINEERING DRAWING	TITLE SURFACE DEVELOPMENT OF OBLIQUE GEOMETRICAL SOLIDS (WITH TRUNCATED).	DRAWN BY NAME ROLL NO	CHECKED BY DATE	DATE	SCALE
					DRAWING NO 81	

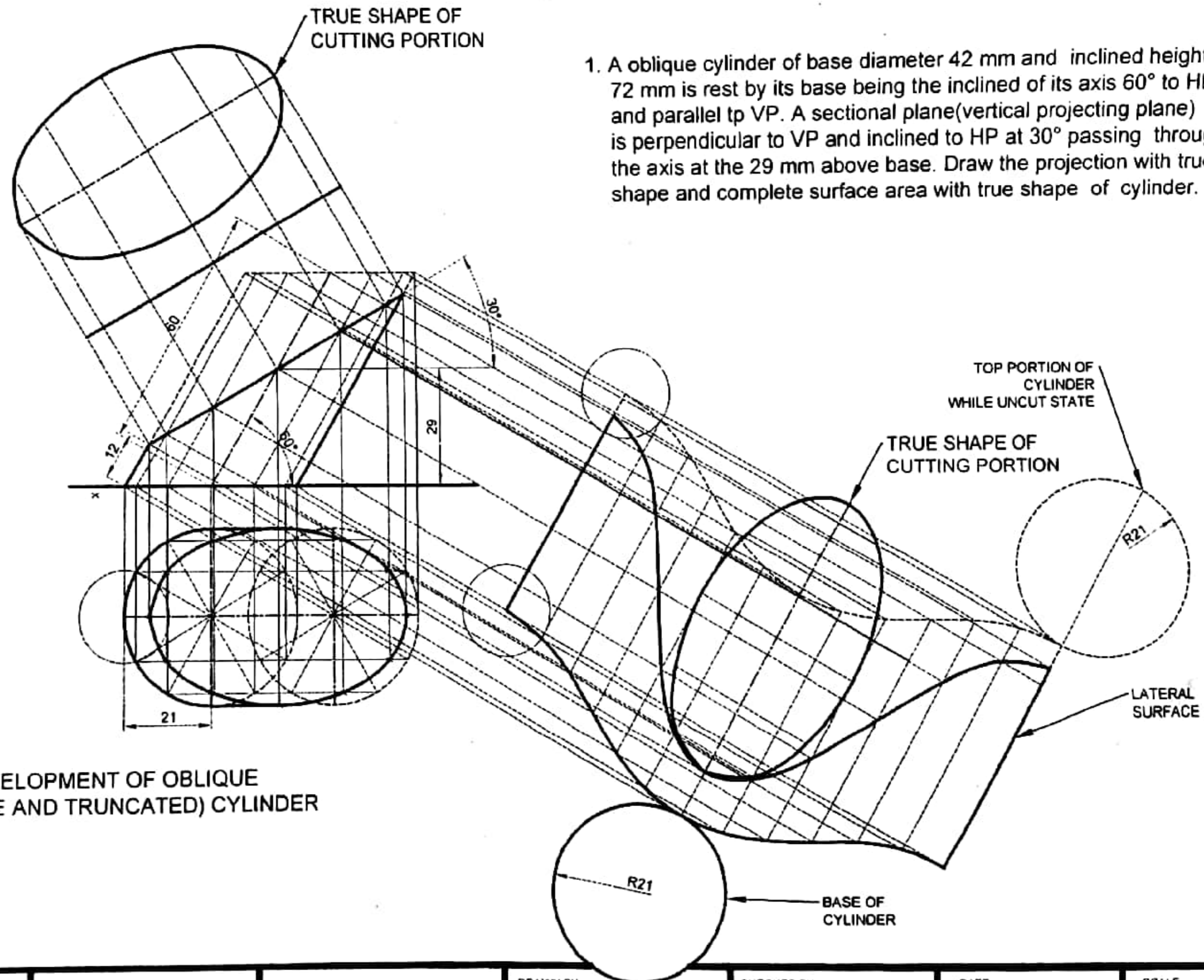

1. A oblique cylinder of base diameter 42 mm and inclined height of 72 mm is rest by its base being the inclined of its axis 60° to HP. and parallel tp VP. A sectional plane(vertical projecting plane) which is perpendicular to VP and inclined to HP at 30° passing through the axis at the 29 mm above base. Draw the projection with true shape and complete surface area with true shape of cylinder.

SURFACE DEVELOPMENT OF OBLIQUE (UNCUT STATE AND TRUNCATED) CYLINDER

TRIBHUVAN UNIVERSITY INSTITUTE OF ENGINEERING THAPATHALI CAMPUS MAITIGHAR, KATHMANDU	SUBJECT ENGINEERING DRAWING	TITLE	DRAWN BY NAME ROLL NO	CHECKED BY DATE	DATE	SCALE
	DRAWING NO 82					82

Draw the lateral surface area of oblique cylinder of 40 mm diameter and it is cut by a vertical projecting plane passing through the axis at 50 mm vertical high, the axis of cylinder is inclined at 60° to HP, right side and parallel to VP. Which figure is given below.

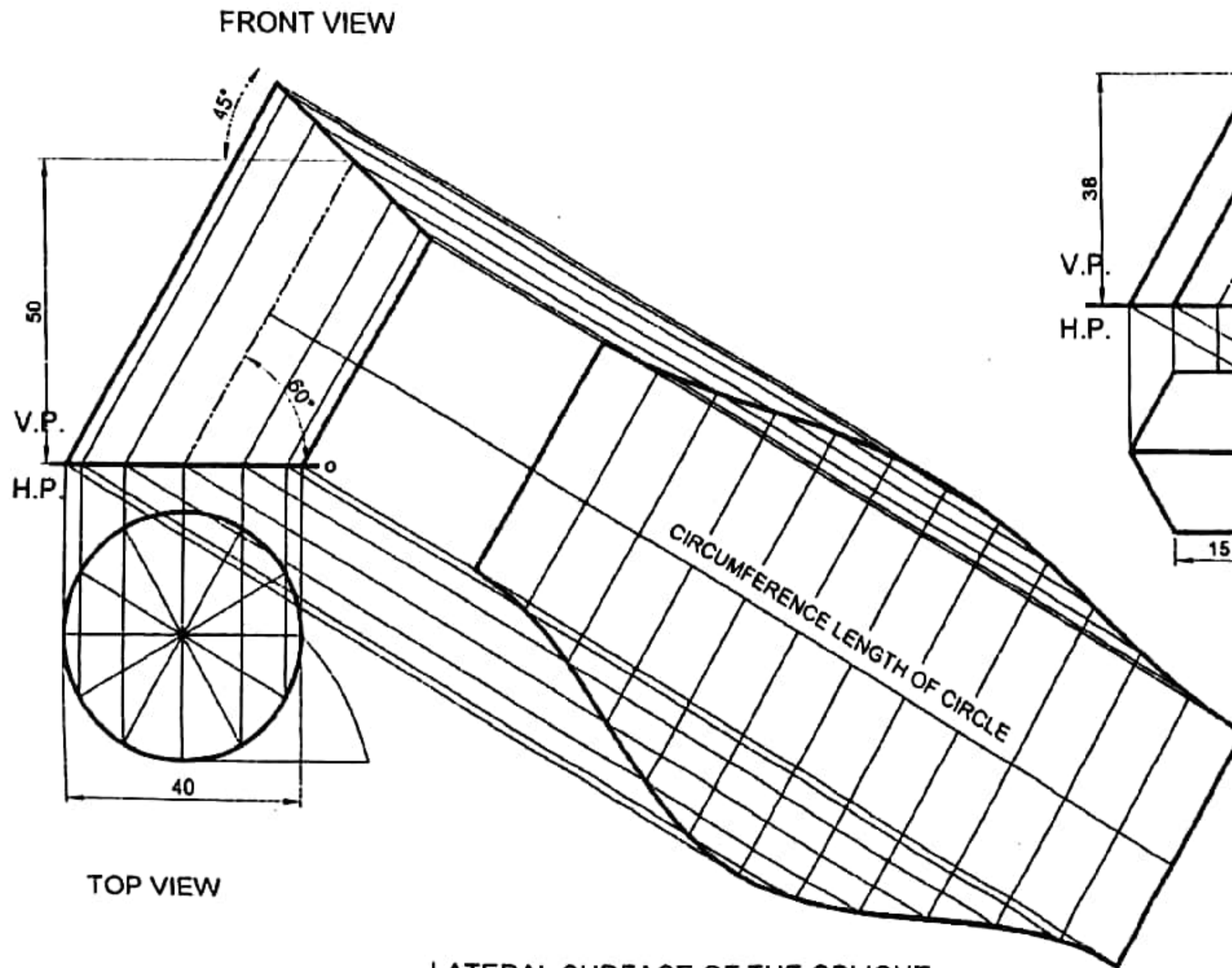

LATERAL SURFACE OF THE OBLIQUE CYLINDER AS PER GIVEN FIGURE.

Draw the lateral surface of a oblique regular hexagonal prism of 15 mm side, it is cut by a vertical projecting plane passing through the axis at 38 mm vertical high inclined to HP 45°, the axis of prism is inclined to HP at 60° to right side and parallel to VP. Which figure is given below.

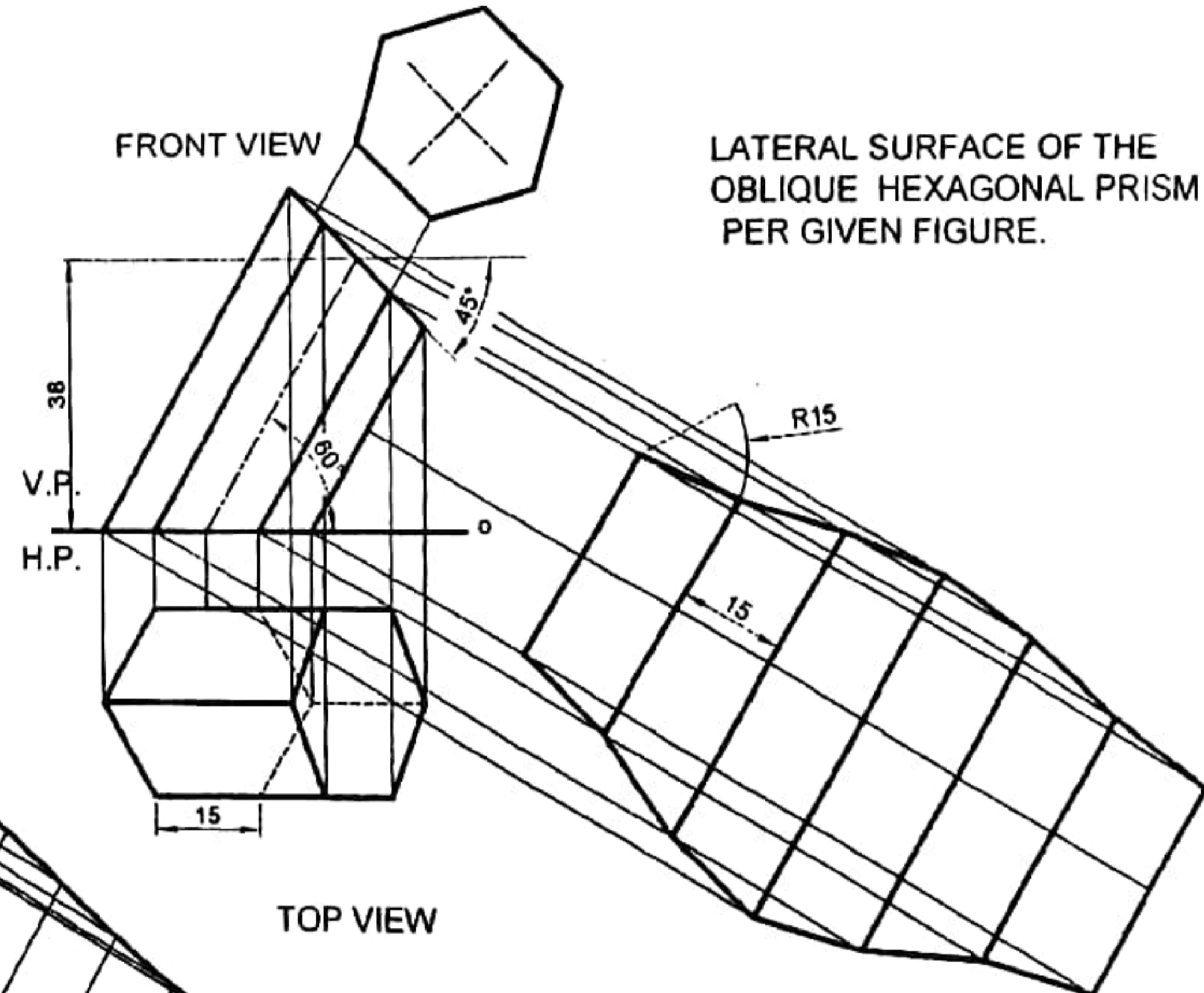

LATERAL SURFACE OF THE OBLIQUE HEXAGONAL PRISM AS PER GIVEN FIGURE.

TRIBHUVAN UNIVERSITY INSTITUTE OF ENGINEERING THAPATHALI CAMPUS MAITIGHAR, KATHMANDU	SUBJECT ENGINEERING DRAWING	TITLE SURFACE DEVELOPMENT OF OBLIQUE GEOMETRICAL SOLIDS (WITH TRUNCATED)	DRAWN BY NAME ROLL NO	CHECKED BY DATE	DATE	SCALE
					DRAWING NO 85	

1. Draw the lateral surface of a cone having the base diameter 45 mm and axial height is 45 mm. It has a hole of 18 mm diameter which axis is 11 mm above the base of cone and it is cut by a vertical projecting plane passing through the 27 mm high above the base, which figure given above. Now you are asked to draw the lateral surface of cone.

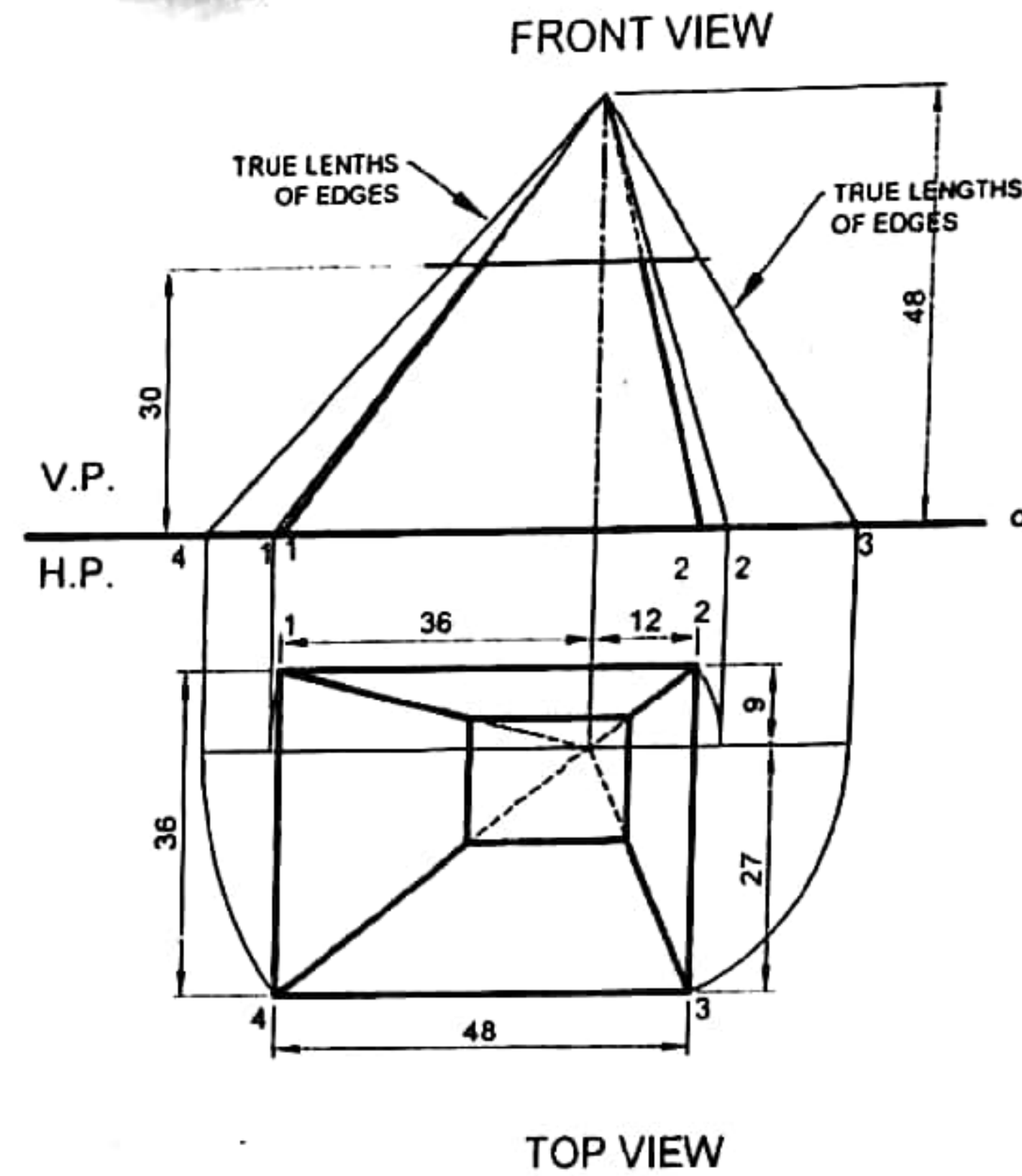
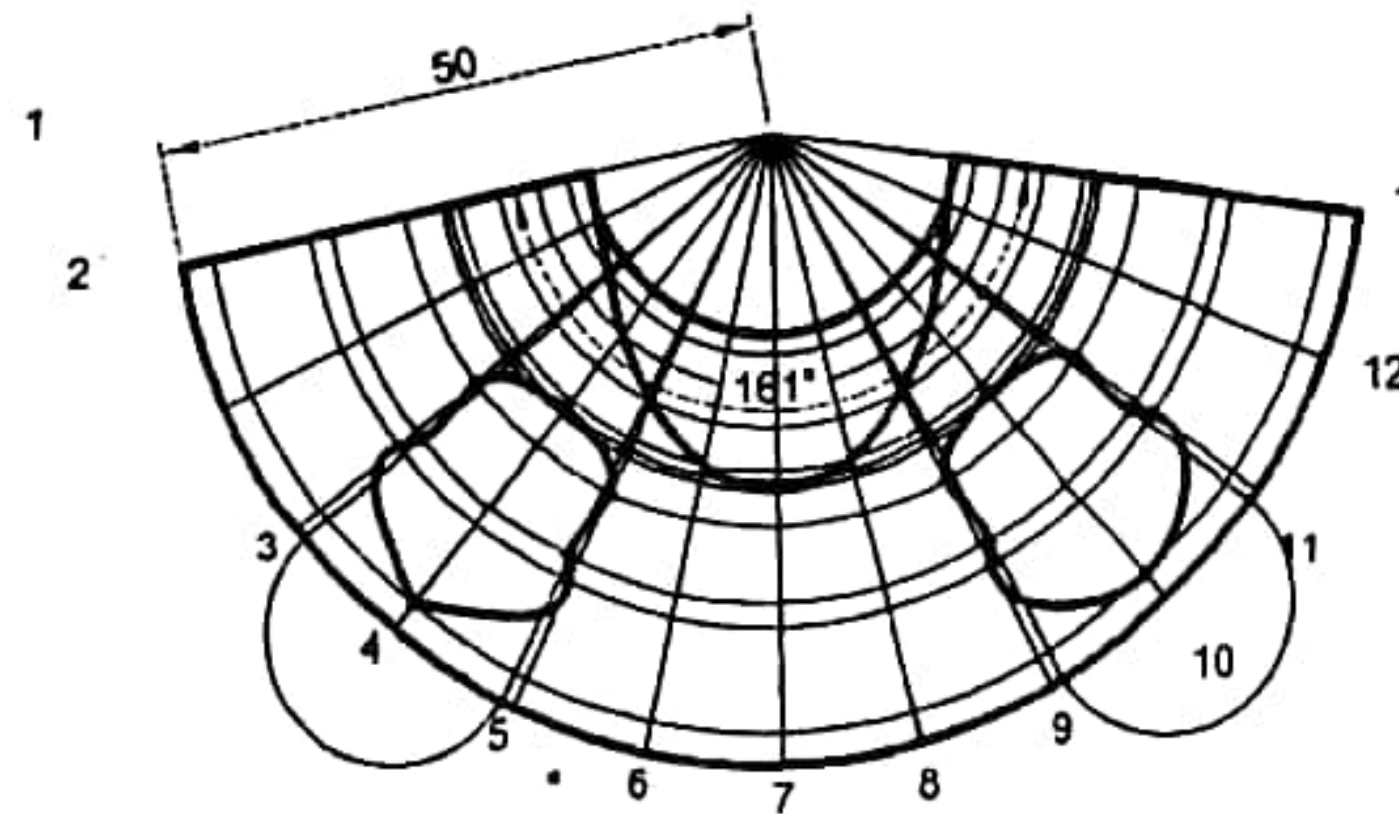
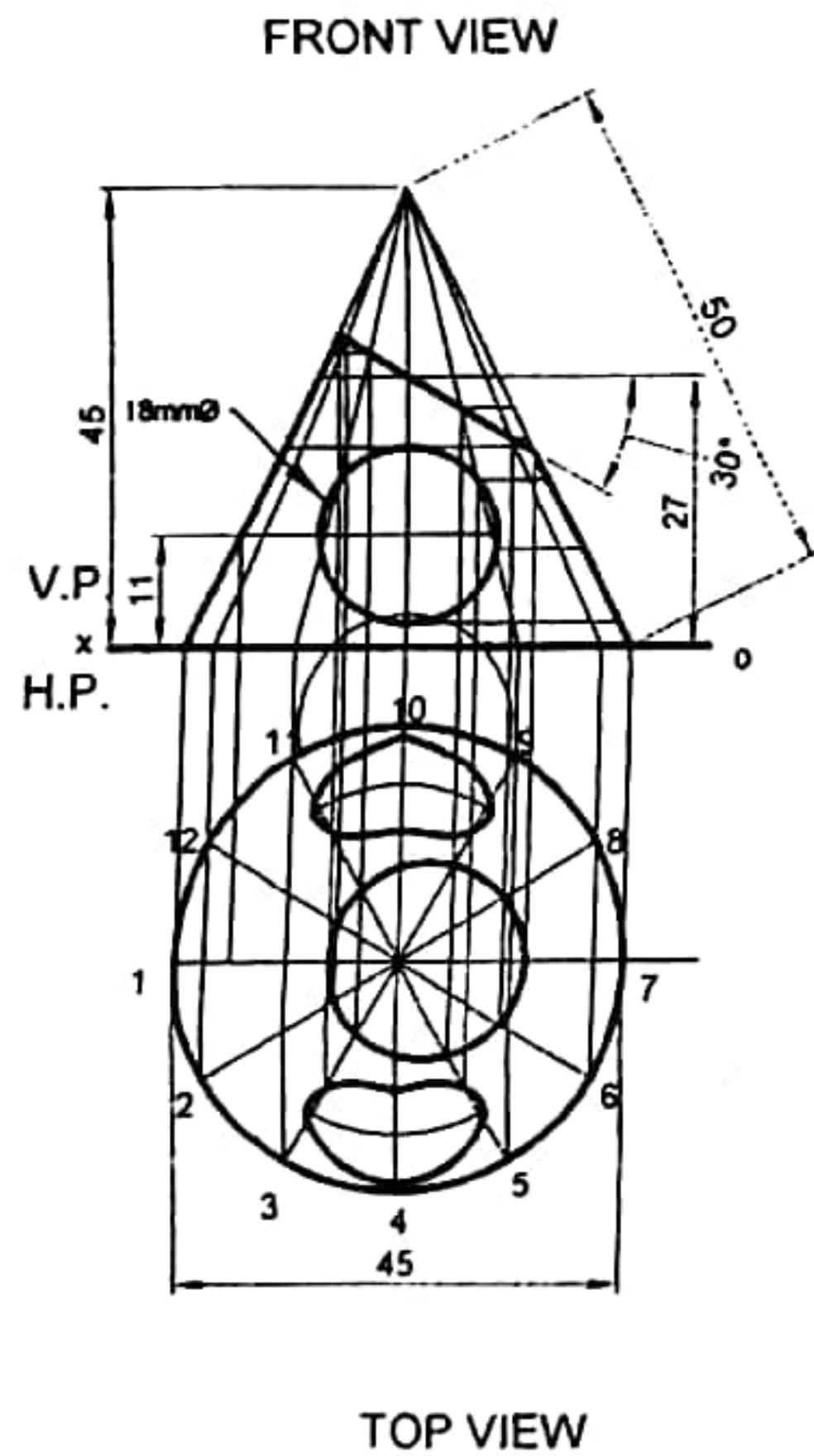

LATERAL SURFACE OF THE OBLIQUE RECTANGULAR BASE PYRAMID AS PER GIVEN FIGURE.

Draw the lateral surface of a oblique rectangular base pyramid of 48 x 36 mm and axial height is 48 mm and apex of pyramid is 9mm front from back side and 12 mm from right side, it is cut by vertical projecting plane which is parallel to HP passing through the 30 mm above the base which figure is given above.

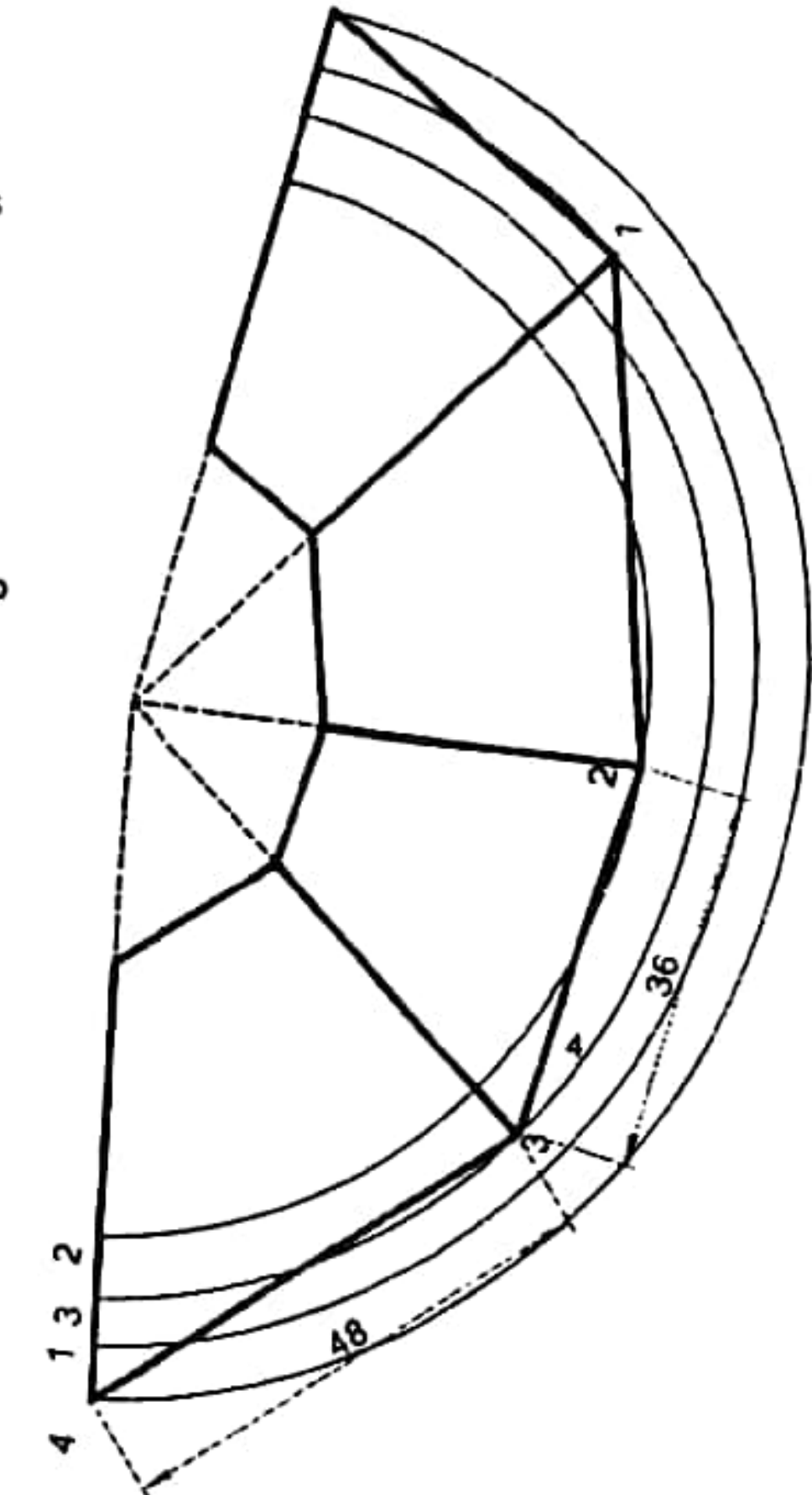

TRIBHUVAN UNIVERSITY INSTITUTE OF ENGINEERING THAPATHALI CAMPUS MAITIGHAR, KATHMANDU	SUBJECT ENGINEERING DRAWING	TITLE SURFACE DEVELOPMENT OF OBLIQUE GEOMETRICAL SOLIDS (WITH TRUNCATED).	DRAWN BY NAME ROLL NO	CHECKED BY DATE	DATE	SCALE
					DRAWING NO 86	

1. A oblique cone of 42 mm diameter and its axis is inclined height is 60 mm is rest on HP by its base being 60° to HP and parallel to VP. A sectional plane which is perpendicular to VP (Vertical projecting Plane) and inclined to HP at 30° passing through the axis at the 26 mm above base. Draw the projection with true shape and complete surface area with true shape of cone.

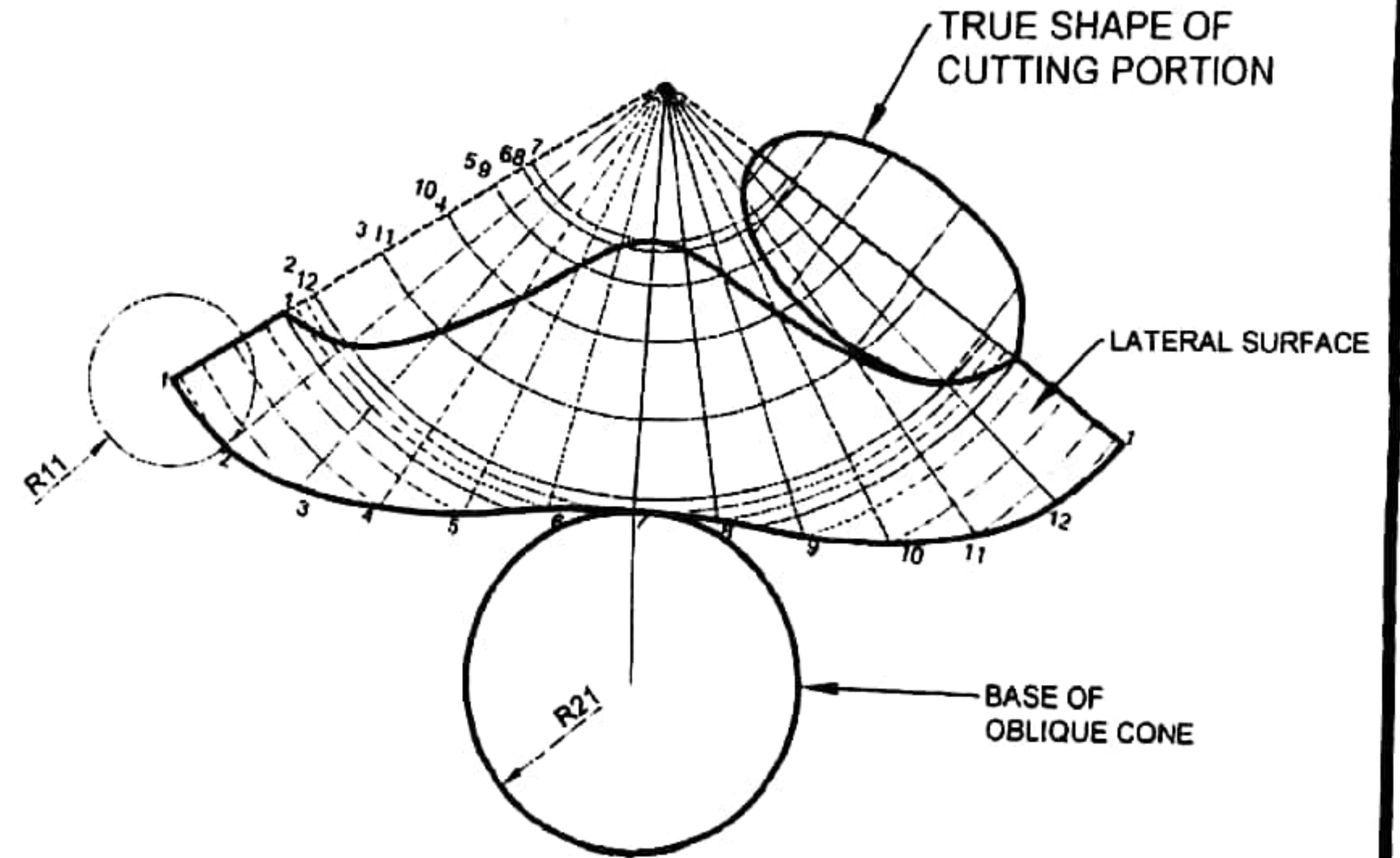
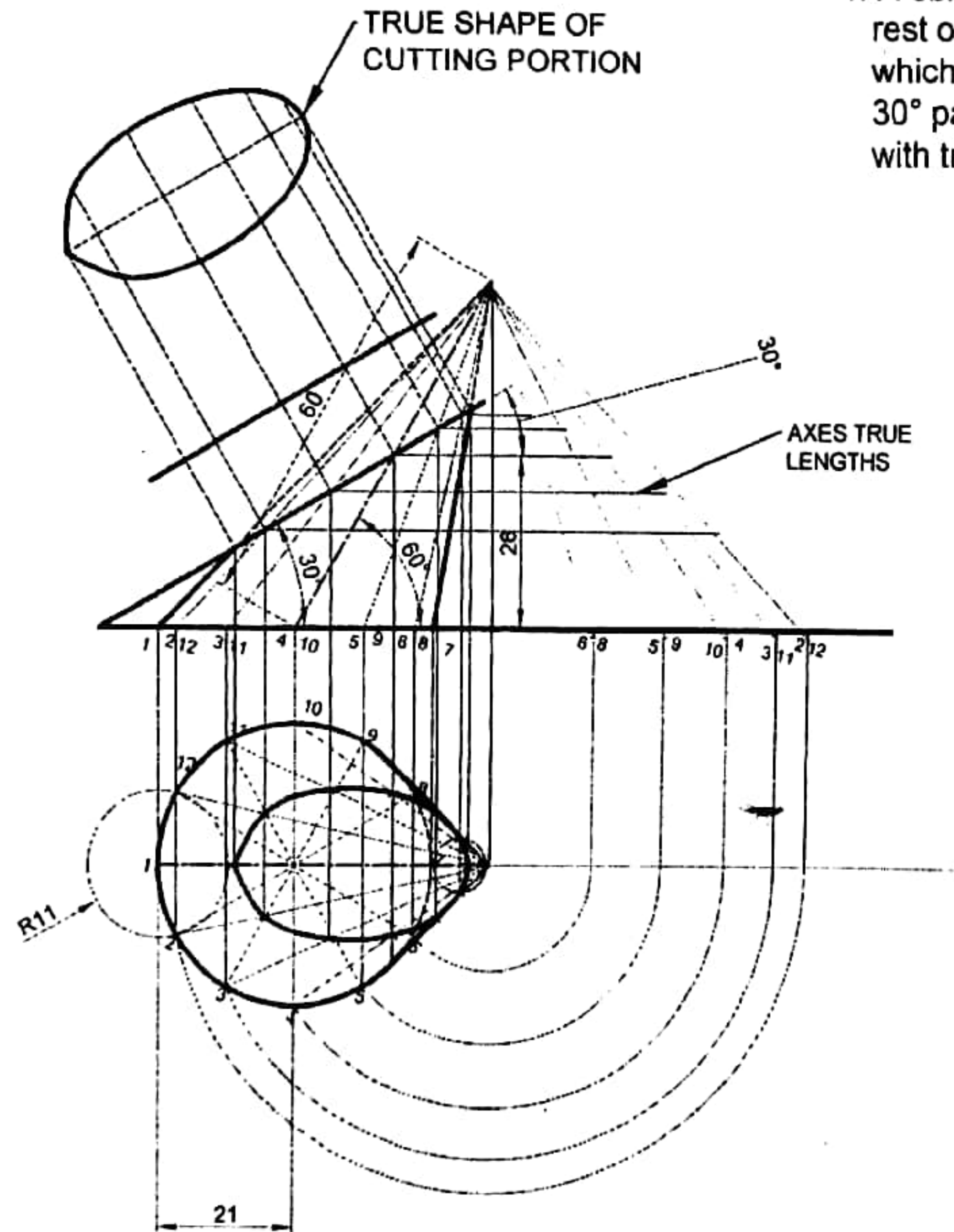

SURFACE DEVELOPMENT OF OBLIQUE (UNCUT STATE AND TRUNCATED) CONE

TRIBHUVAN UNIVERSITY INSTITUTE OF ENGINEERING THAPATHALI CAMPUS MAITIGHAR, KATHMANDU	SUBJECT	TITLE	DRAWN BY	CHECKED BY	DATE	SCALE
	ENGINEERING DRAWING		NAME ROLL NO			
				DATE	DRAWING NO	83

An oblique square base pyramid of base edge 35 mm and vertical height is 50 mm its apex point is 10 mm far from extreme right edge of base and 50mm high, It is cut by a vertical projecting plane which is inclined to HP at 30° and passing through at 27 mm above the HP Draw the whole surface area including with true shape.

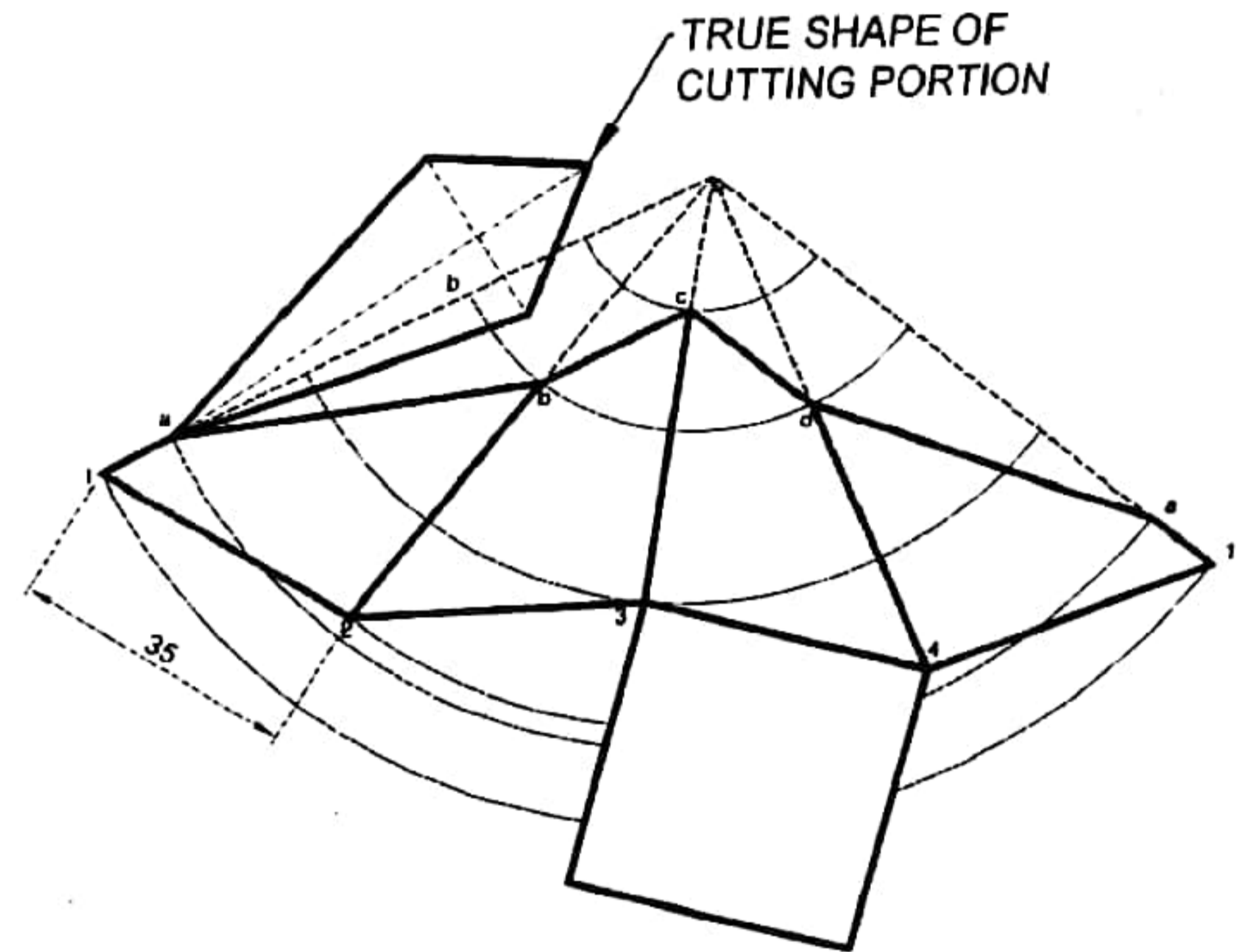
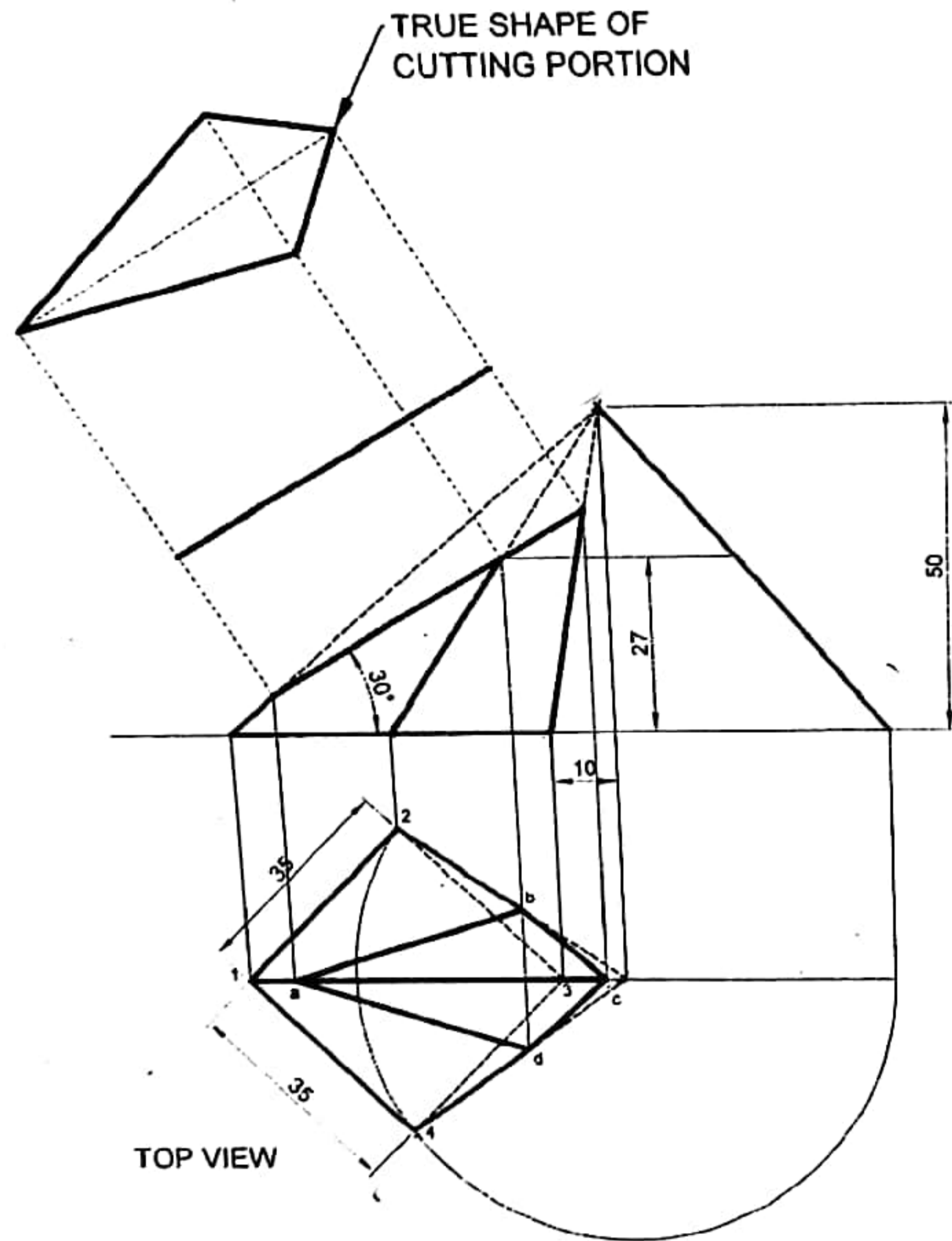

SURFACE DEVELOPMENT OF(UNCUT STATE AND TRUNCATED) SQUARE BASE OBLIQUE PYRAMID

TRENKUN UNIVERSITY INSTITUTE OF ENGINEERING THAPATHALI CAMPUS MAITIGHAR, KATHMANDU	SUBJECT	TITLE	DRAWN BY	CHECKED BY	DATE	SCALE
	ENGINEERING DRAWING		NAME ROLL NO			
				DATE	DRAWING NO	84

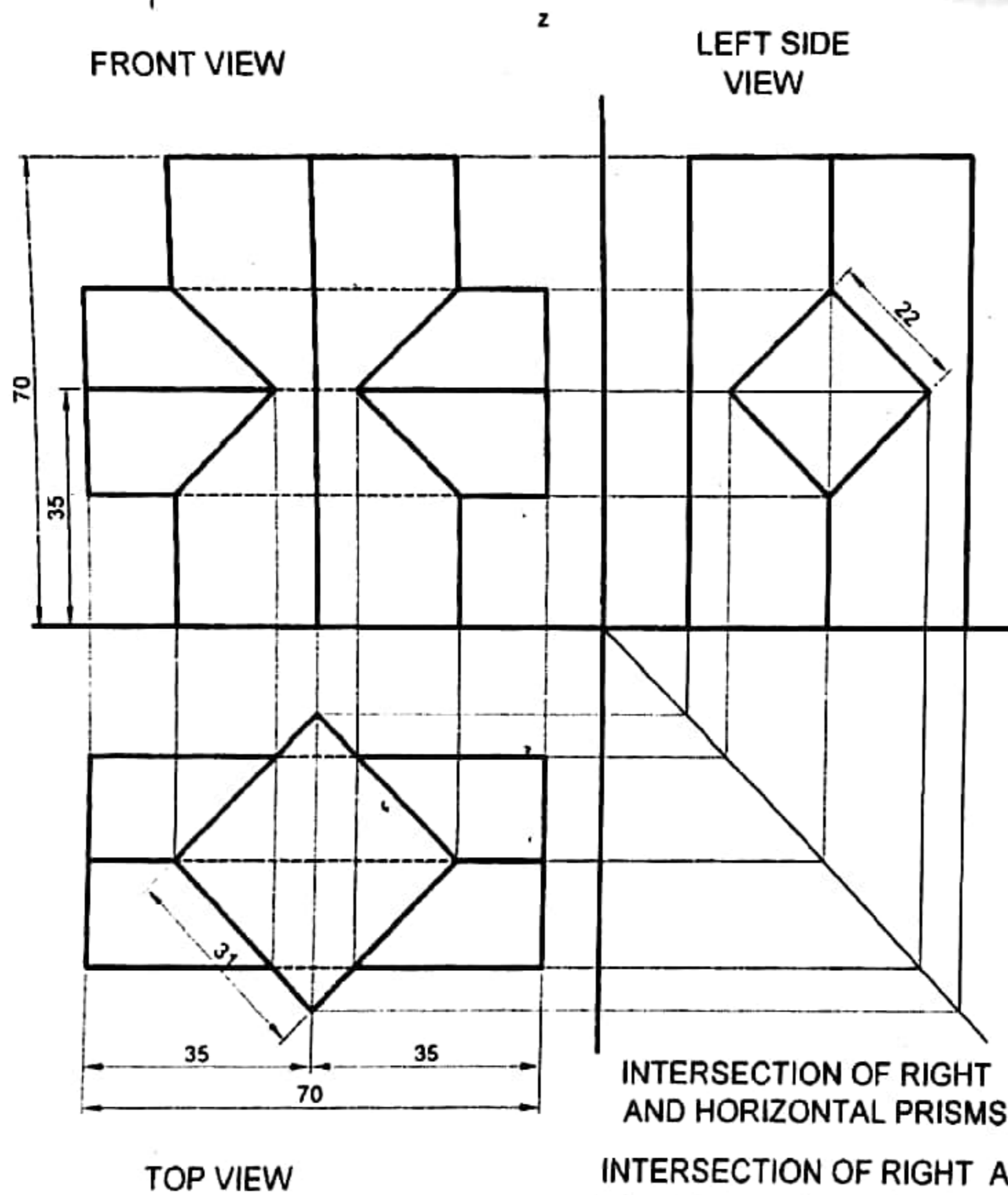

INTERSECTION OF RIGHT AND HORIZONTAL PRISMS
 INTERSECTION OF RIGHT AND HORIZONTAL PRISMS' SURFACES
 (axes of two cylinder are coincided / coincided)

A right square prism of 31 mm side and 70mm high resting on HP by its base, it is completely penetrated by another square prism of 22 mm side and 70 mm long, such that axes of two prism bisect each other at right angles, the faces of both prisms are equally inclined to VP, Draw the projections of both prism showing the line of intersection.

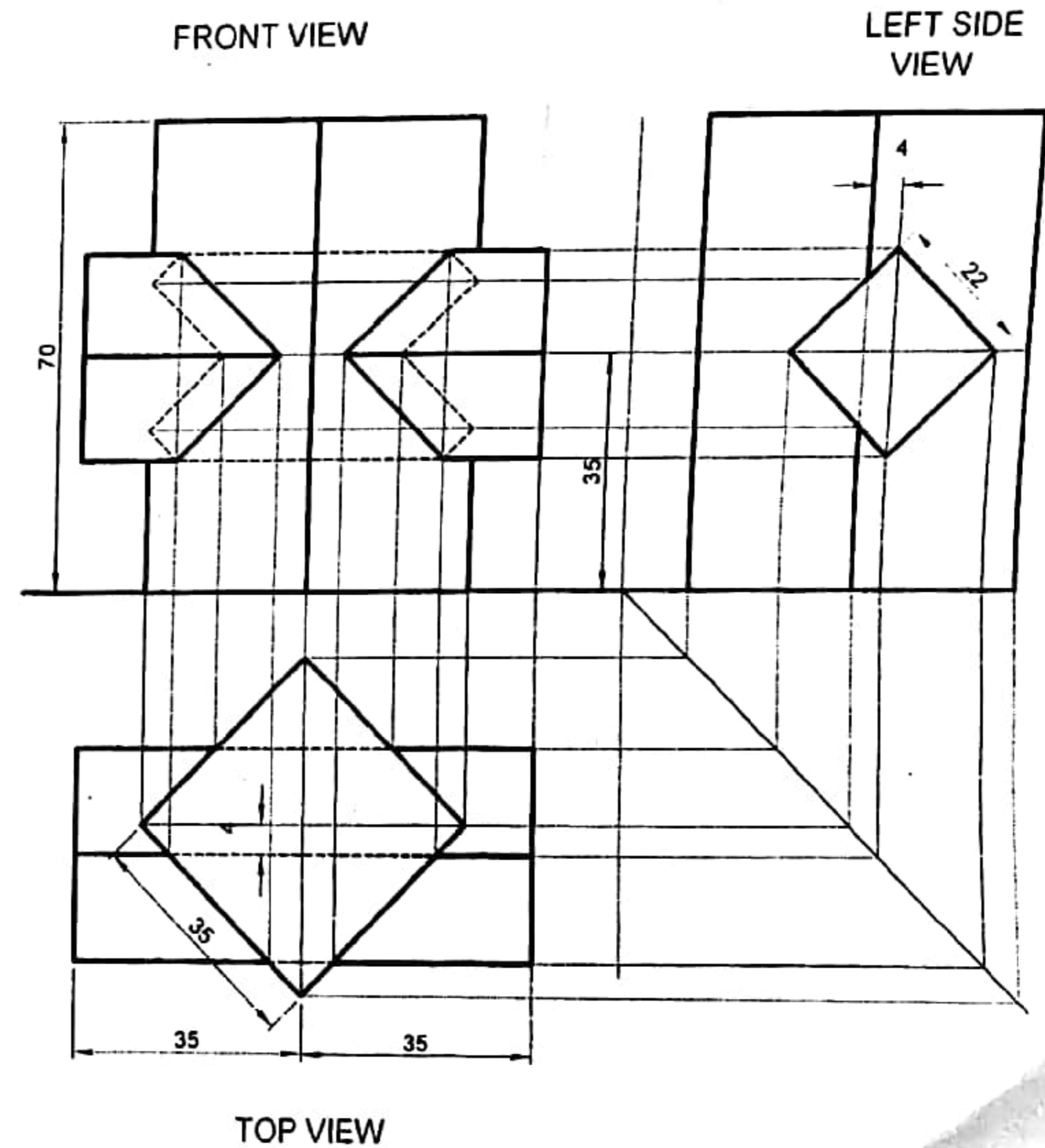

A right square prism of 35 mm side and 70mm high resting on HP by its base, it is completely penetrated by another square prism of 22 mm side and 70 mm long, such that axis of penetrating prism is perpendicular to and 4 mm in front of the right prism axis and 35 mm above the right prism, the rectangular faces of both prisms equally inclined to VP, Draw the projections of both prism showing the line of intersection. (seen and unseen both)

SUBJECT ENGINEERING DRAWING	TITLE INTERSECTION OF TWO SOLIDS (INTERSECTION OF TWO SURFACES)	DRAWN BY NAME ROLL NO	CHECKED BY	DATE	SCALE
			DATE	DRAWING NO	88

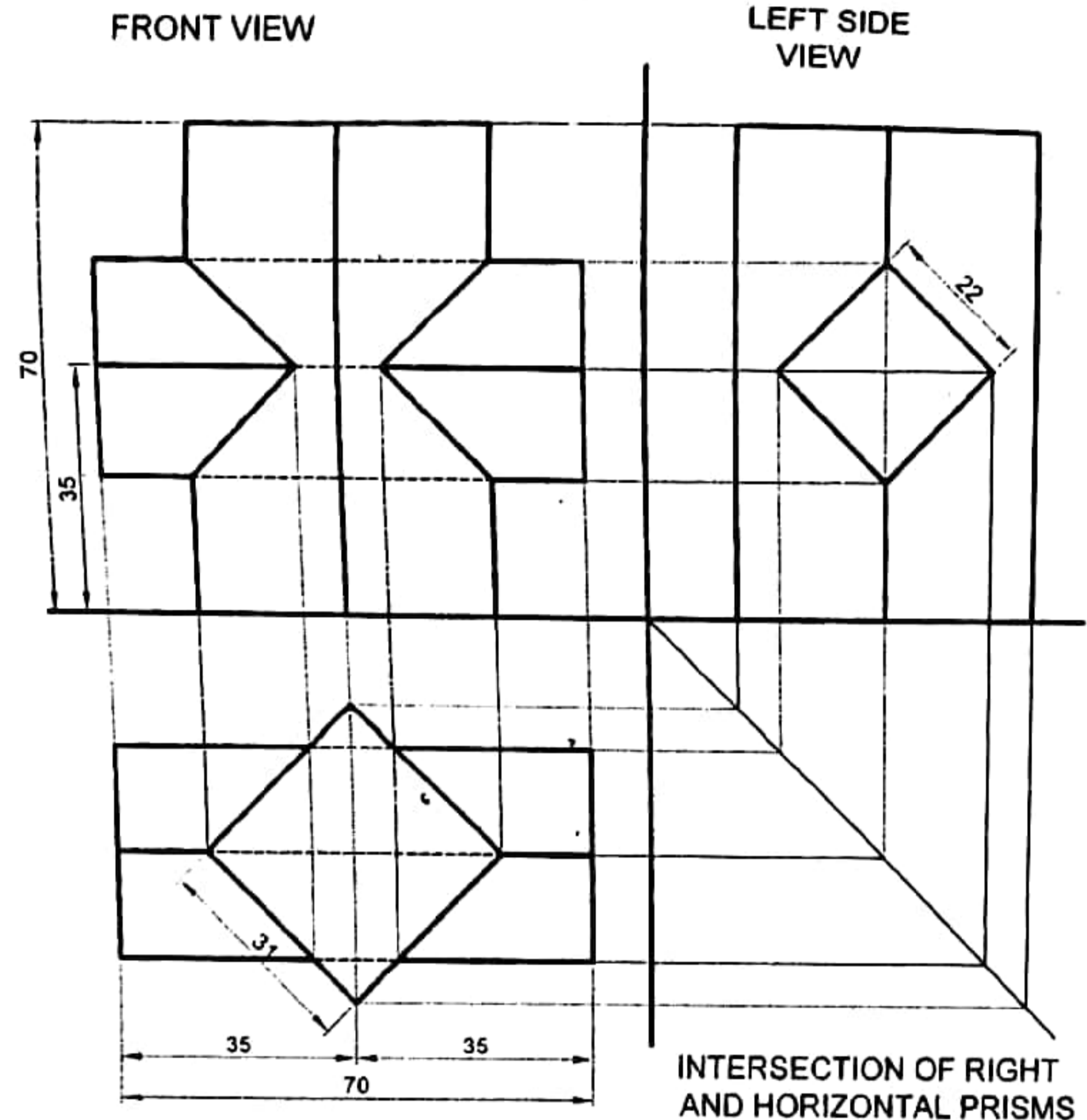

FRONT VIEW

LEFT SIDE VIEW

TOP VIEW

INTERSECTION OF RIGHT AND HORIZONTAL PRISMS

INTERSECTION OF RIGHT AND HORIZONTAL PRISMS' SURFACES
(axes of two cylinder are coincided / coincided)

A right square prism of 31 mm side and 70mm high resting on HP by its base, it is completely penetrated by another square prism of 22 mm side and 70 mm long, such that axes of two prism bisect each other at rightangles, the faces of both prisms are equally inclined to VP, Draw the projections of both prism showing the line of intersection.

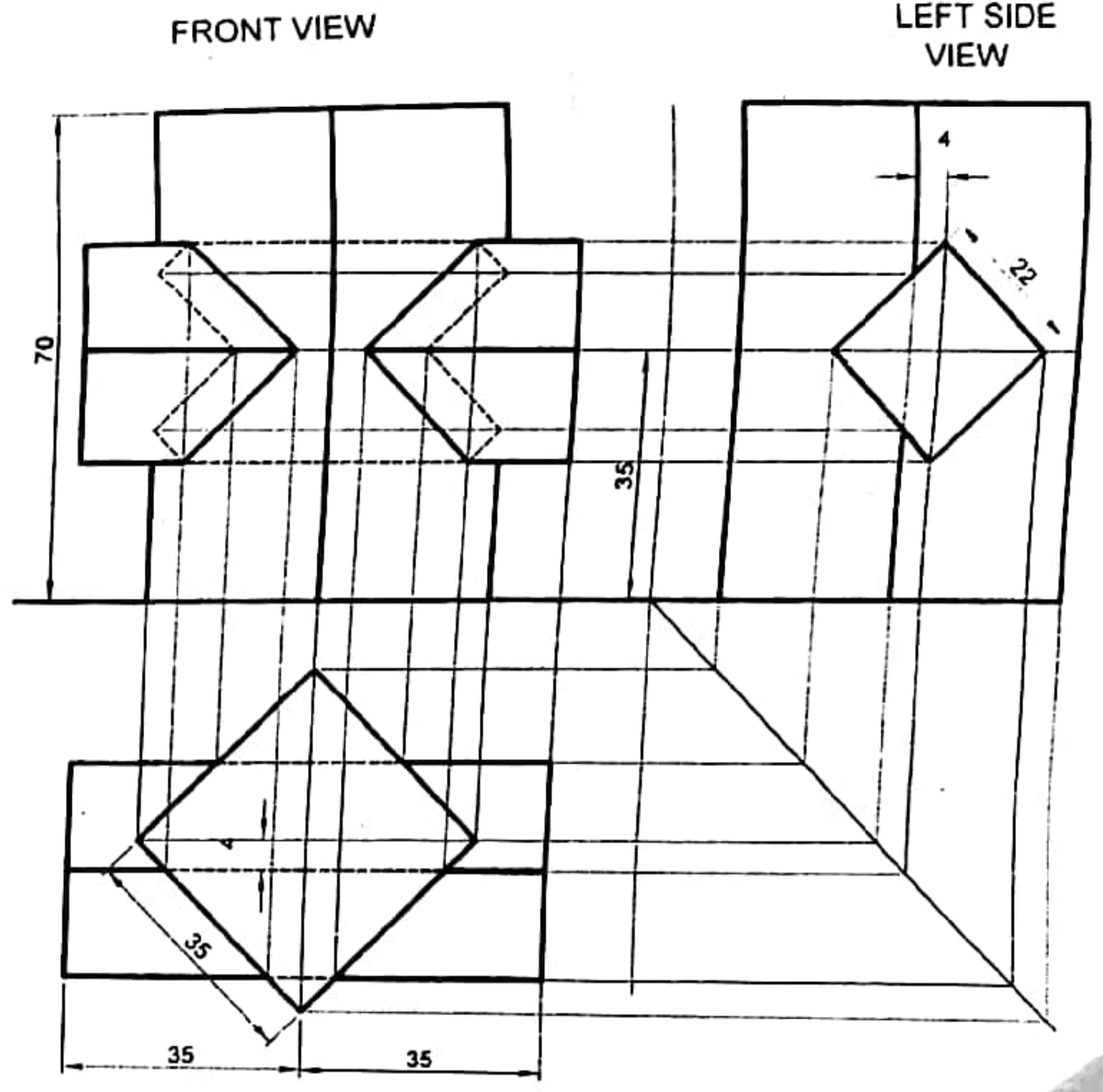

FRONT VIEW

LEFT SIDE VIEW

TOP VIEW

A right square prism of 35 mm side and 70mm high resting on HP by its base, it is completely penetrated by another square prism of 22 mm side and 70 mm long, such that axis of penetrating prism is perpendicular to and 4 mm in front of the right prism axis and 35 mm above the right prism, the rectangular faces of both prisms equally inclined to VP, Draw the projections of both prism showing the line of intersection. (seen and unseen both)

SUBJECT ENGINEERING DRAWING	TITLE INTERSECTION OF TWO SOLIDS (INTERSECTION OF TWO SURFACES)	DRAWN BY NAME ROLL NO	CHECKED BY	DATE	SCALE
			DATE	DRAWING NO 88	

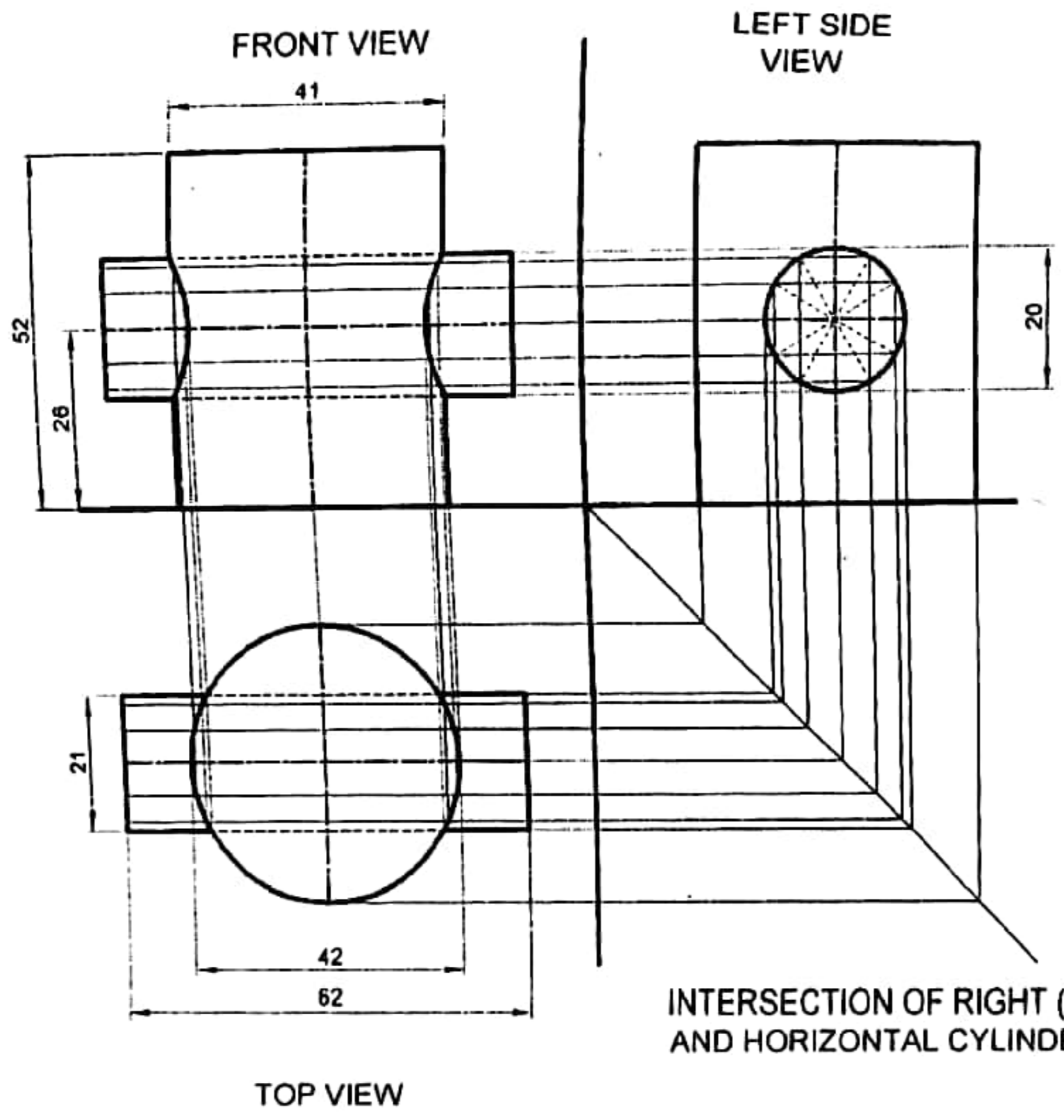

INTERSECTION OF RIGHT (VERTICAL) CYLINDER AND HORIZONTAL CYLINDER (UNEQUAL SIZE)

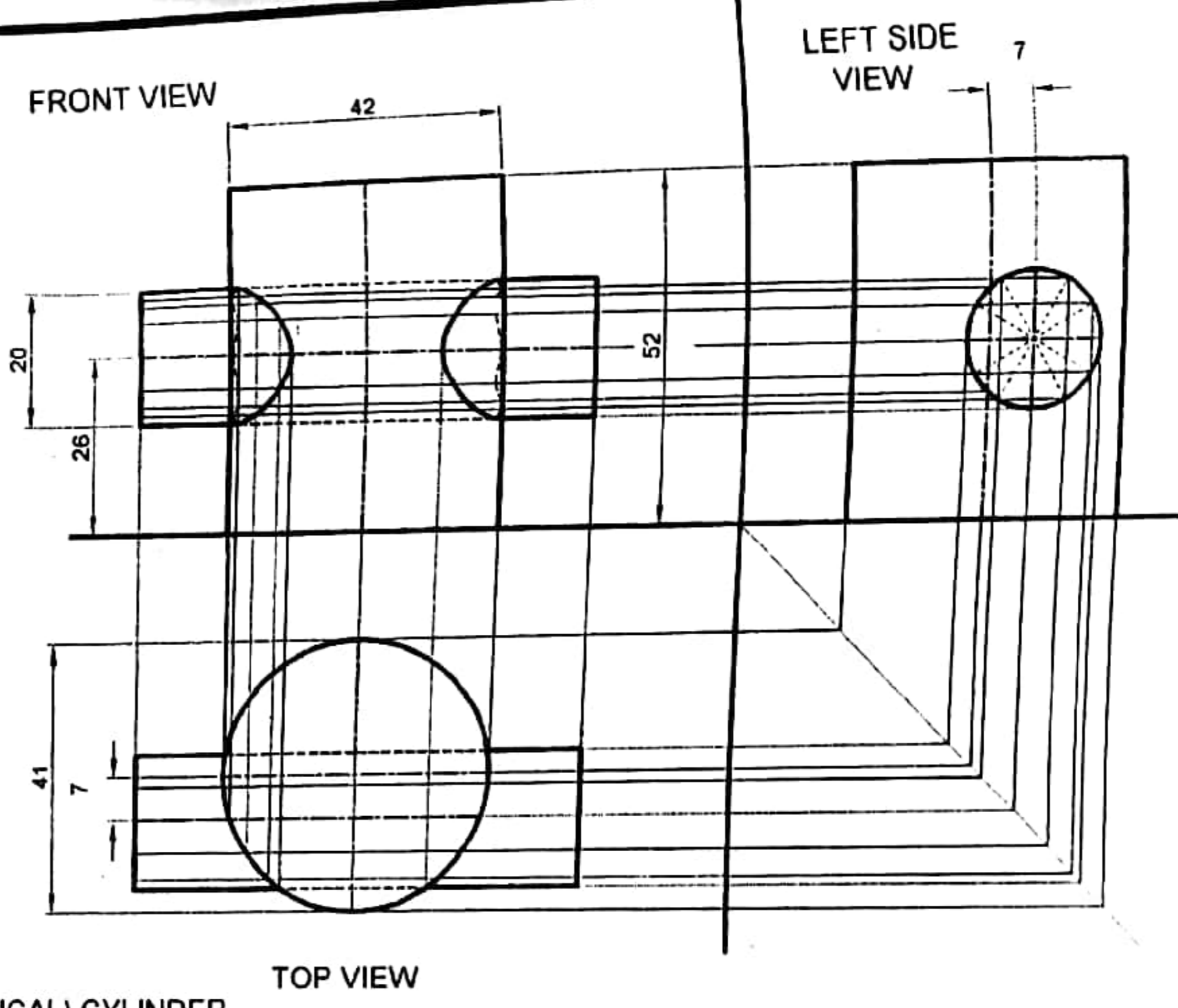

TOP VIEW

A right cylinder of 42 mm diameter 52 mm high resting on HP by its base, it is completely penetrated by another horizontal cylinder of 20 mm diameter and 62 mm long, such that their axes are bisected each other and right angles, the axis of penetrated cylinder is parallel to VP. Draw the projection both cylinder showing curve of intersection. (the axis of penetrated cylinder is 26 mm above the base of right cylinder)

A right cylinder of 42 mm diameter 52 mm high resting on HP by its base, it is completely penetrated by another horizontal cylinder of 20 mm diameter and 62 mm long, such that penetrating cylinder passing through 26mm above the right cylinder and 7mm in front of right cylinder axis. Draw the projections of both cylinder showing the curve of intersection (seen and unseen).

SUBJECT ENGINEERING DRAWING	TITLE INTERSECTION OF TWO SOLIDS (INTERSECTION OF TWO SURFACES)	DRAWN BY NAME ROLL NO	CHECKED BY	DATE	SCALE
				DRAWING NO 89	
			DATE		

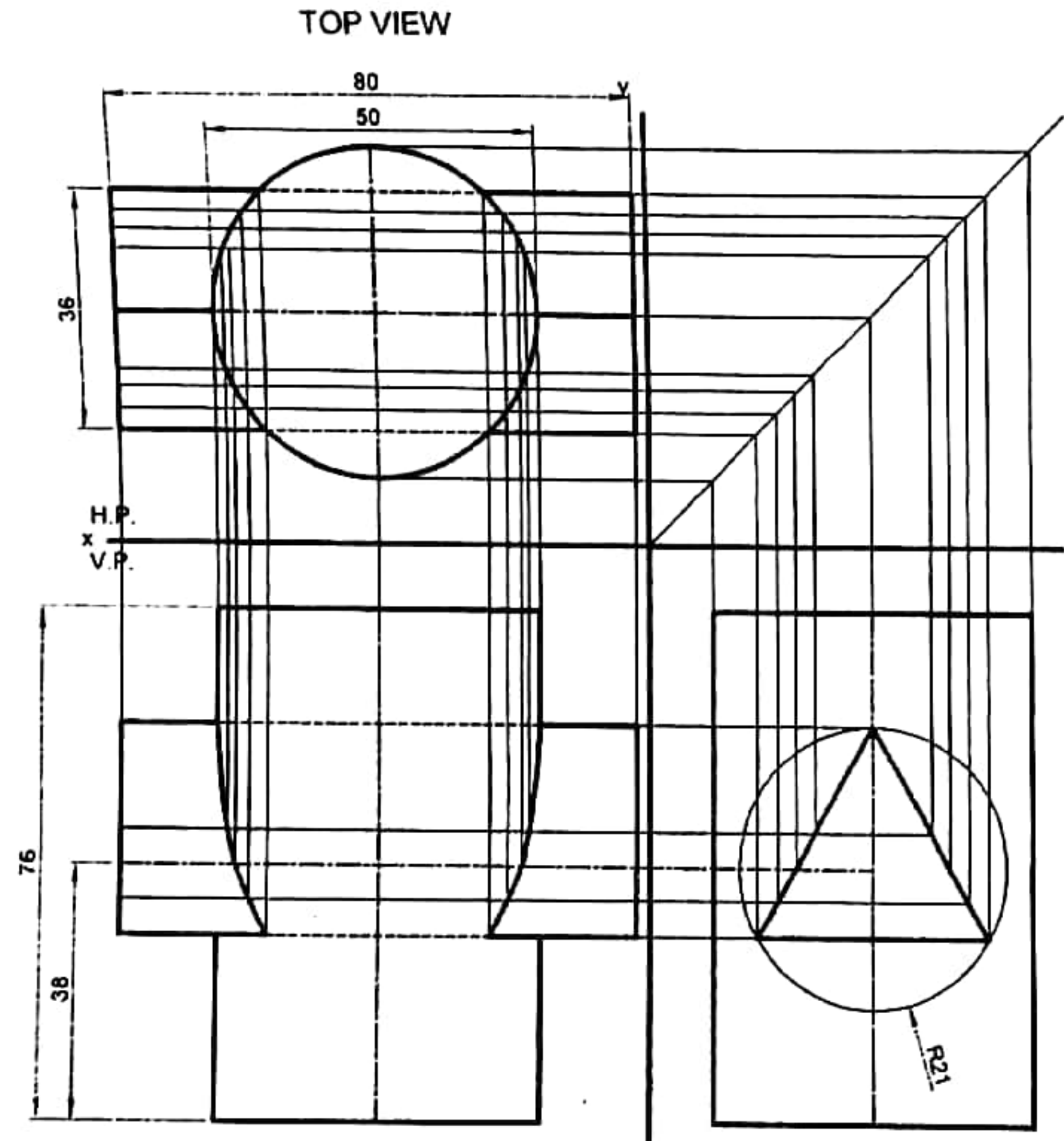

TOP VIEW
 FRONT VIEW
 RIGHT SIDE VIEW
 INTERSECTION OF RIGHT CYLINDER AND HORIZONTAL TRIANGULAR PRISM

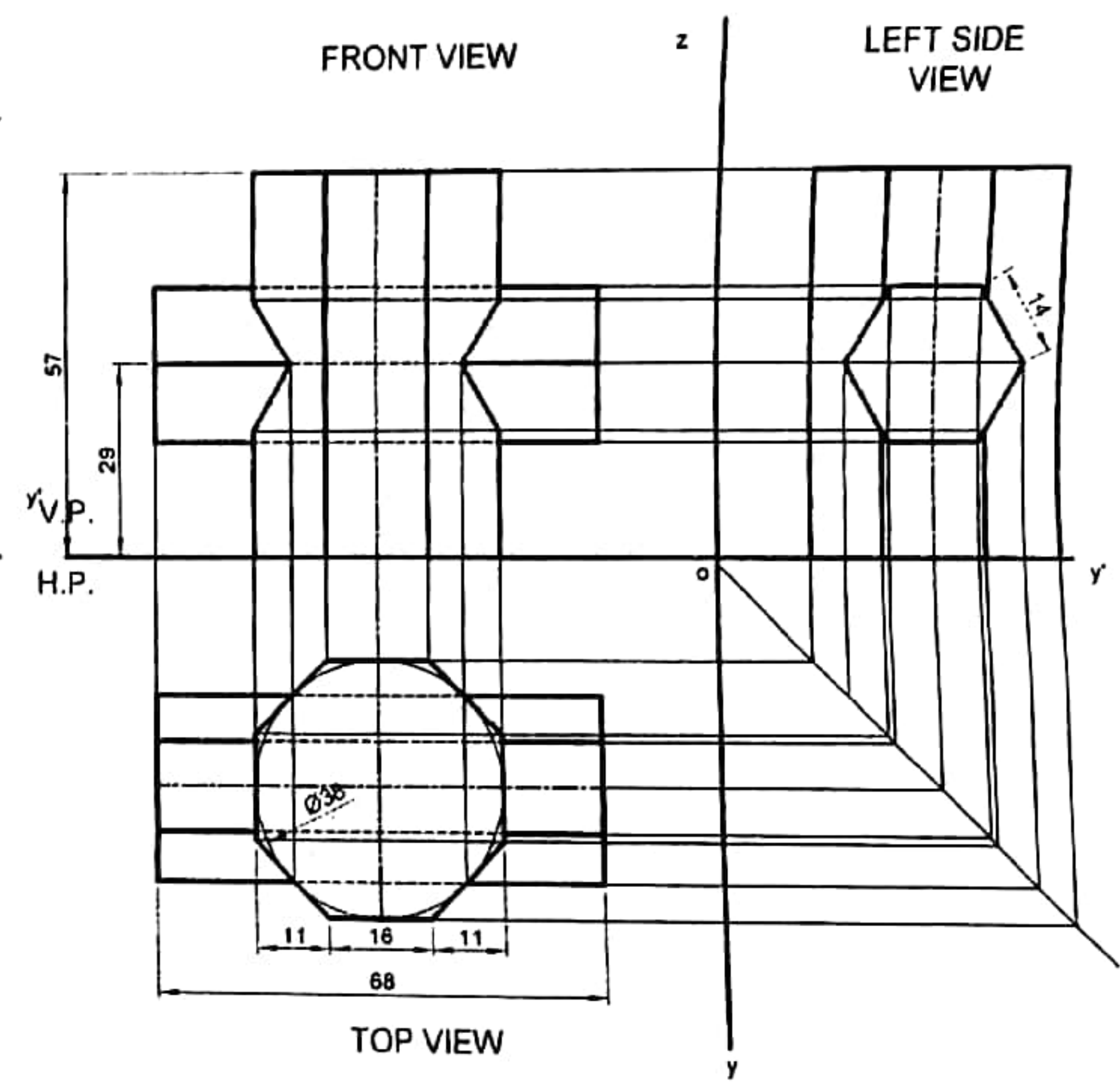

FRONT VIEW
 LEFT SIDE VIEW
 TOP VIEW
 INTERSECTION BETWEEN RIGHT OCTAGONAL PRISM AND HORIZONTAL HEXAGONAL PRISMS

	SUBJECT	TITLE	DRAWN BY	CHECKED BY	DATE	SCALE
	ENGINEERING DRAWING	INTERSECTION OF TWO SOLIDS (INTERSECTION OF TWO SURFACES)	NAME ROLL NO			
				DATE	DRAWING NO 90	

FRONT VIEW

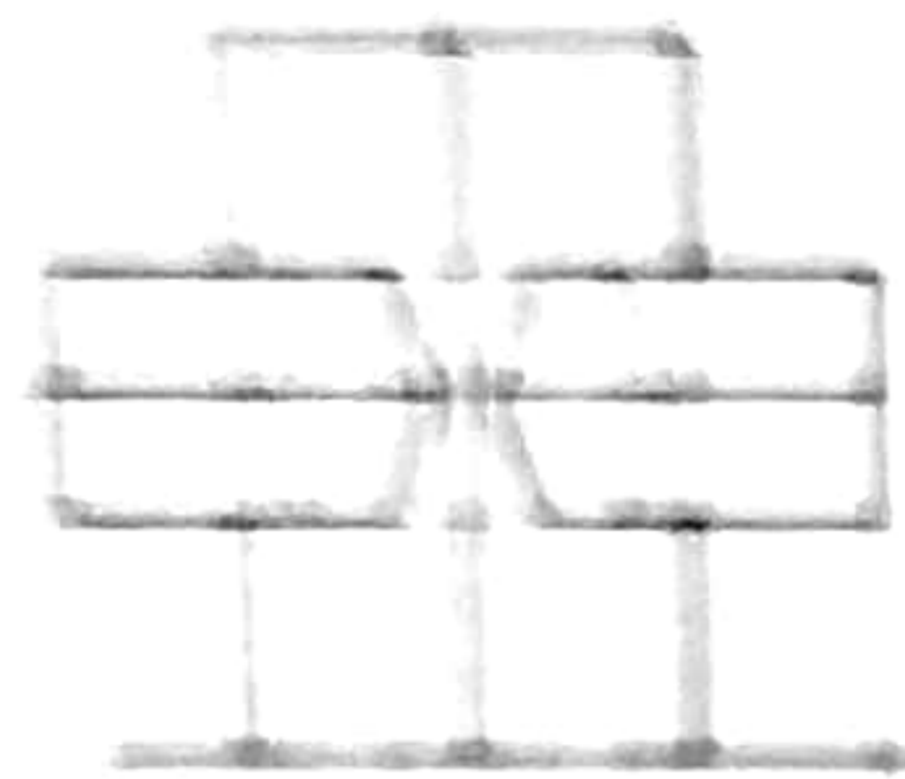

LEFT SIDE VIEW

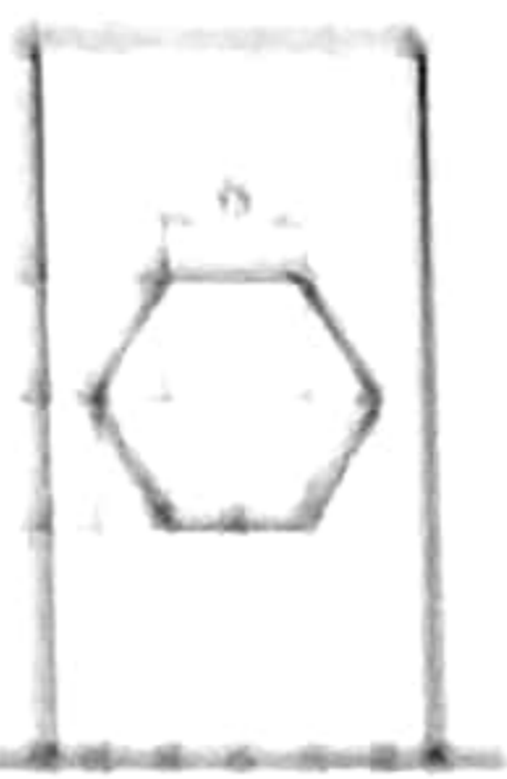

RIGHT SIDE VIEW

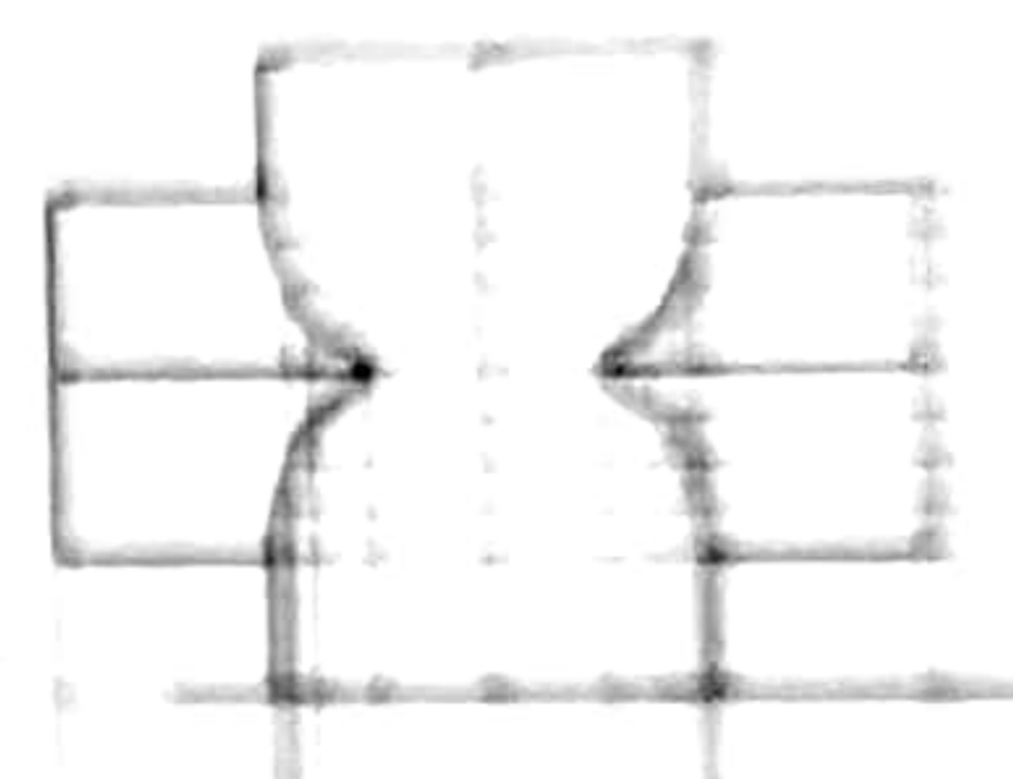
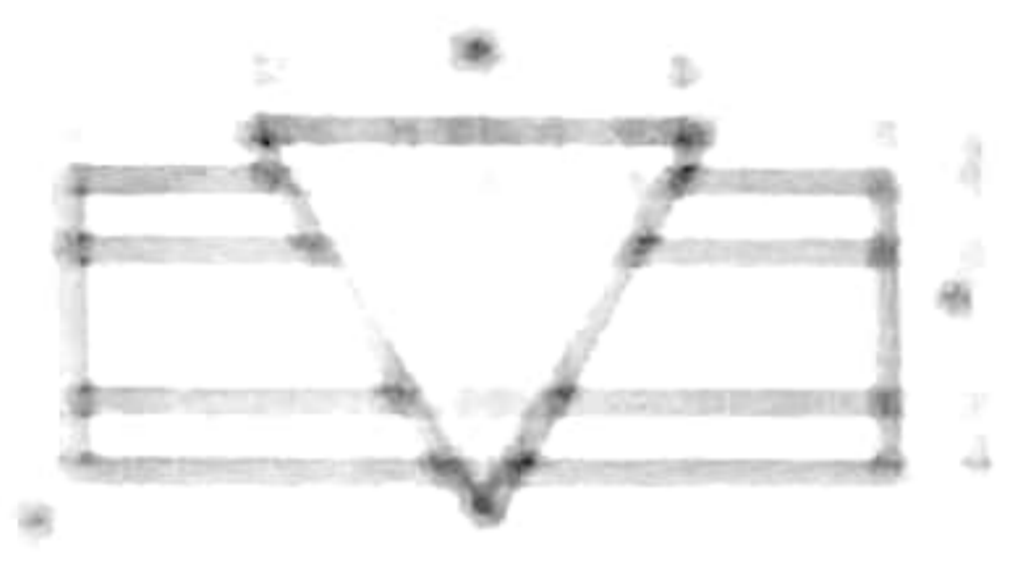

CONSTRUCTION OF THE FRONT AND TOP VIEWS OF THE PART SHOWN IN THE FIGURE. THE PART IS A RECTANGULAR BLOCK WITH A V-CUTOUT IN THE TOP SURFACE.

CONSTRUCTION OF THE FRONT AND TOP VIEWS OF THE PART SHOWN IN THE FIGURE. THE PART IS A RECTANGULAR BLOCK WITH A CIRCULAR HOLE IN THE TOP SURFACE.

		<p>CONSTRUCTION OF THE FRONT AND TOP VIEWS OF THE PART SHOWN IN THE FIGURE. THE PART IS A RECTANGULAR BLOCK WITH A V-CUTOUT IN THE TOP SURFACE.</p>		<p>CONSTRUCTION OF THE FRONT AND TOP VIEWS OF THE PART SHOWN IN THE FIGURE. THE PART IS A RECTANGULAR BLOCK WITH A CIRCULAR HOLE IN THE TOP SURFACE.</p>		
--	--	---	--	--	--	--

FRONT VIEW

LEFT SIDE VIEW

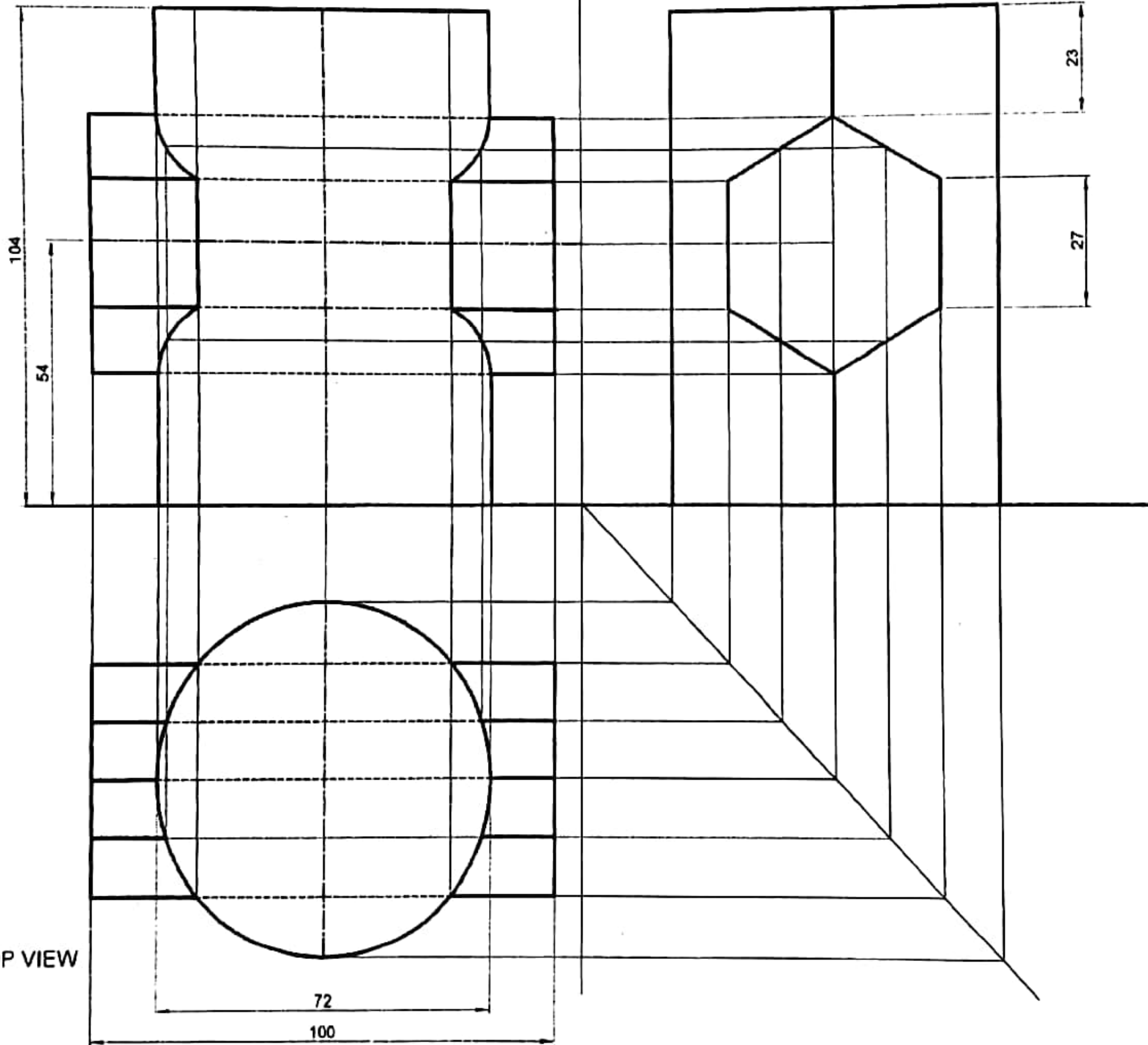

TOP VIEW

SUBJECT

ENGINEERING DRAWING

TITLE

INTERSECTION OF TWO SOLIDS (INTERSECTION OF TWO SURFACES)

DRAWN BY

NAME
ROLL NO

CHECKED BY

DATE

DATE

SCALE

DRAWING NO

93

91

FRONT VIEW

LEFT SIDE VIEW

FRONT VIEW

LEFT SIDE VIEW

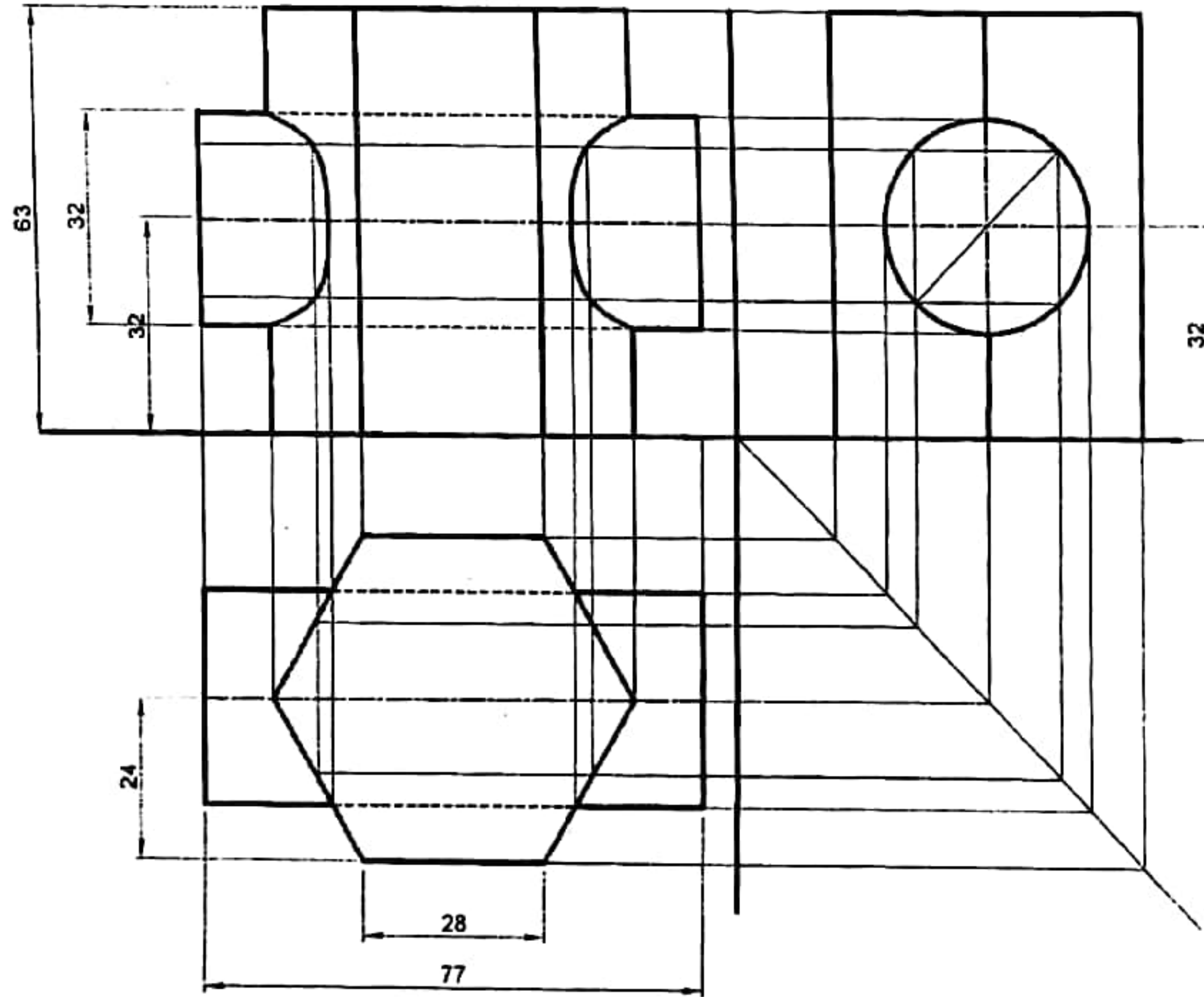

TOP VIEW

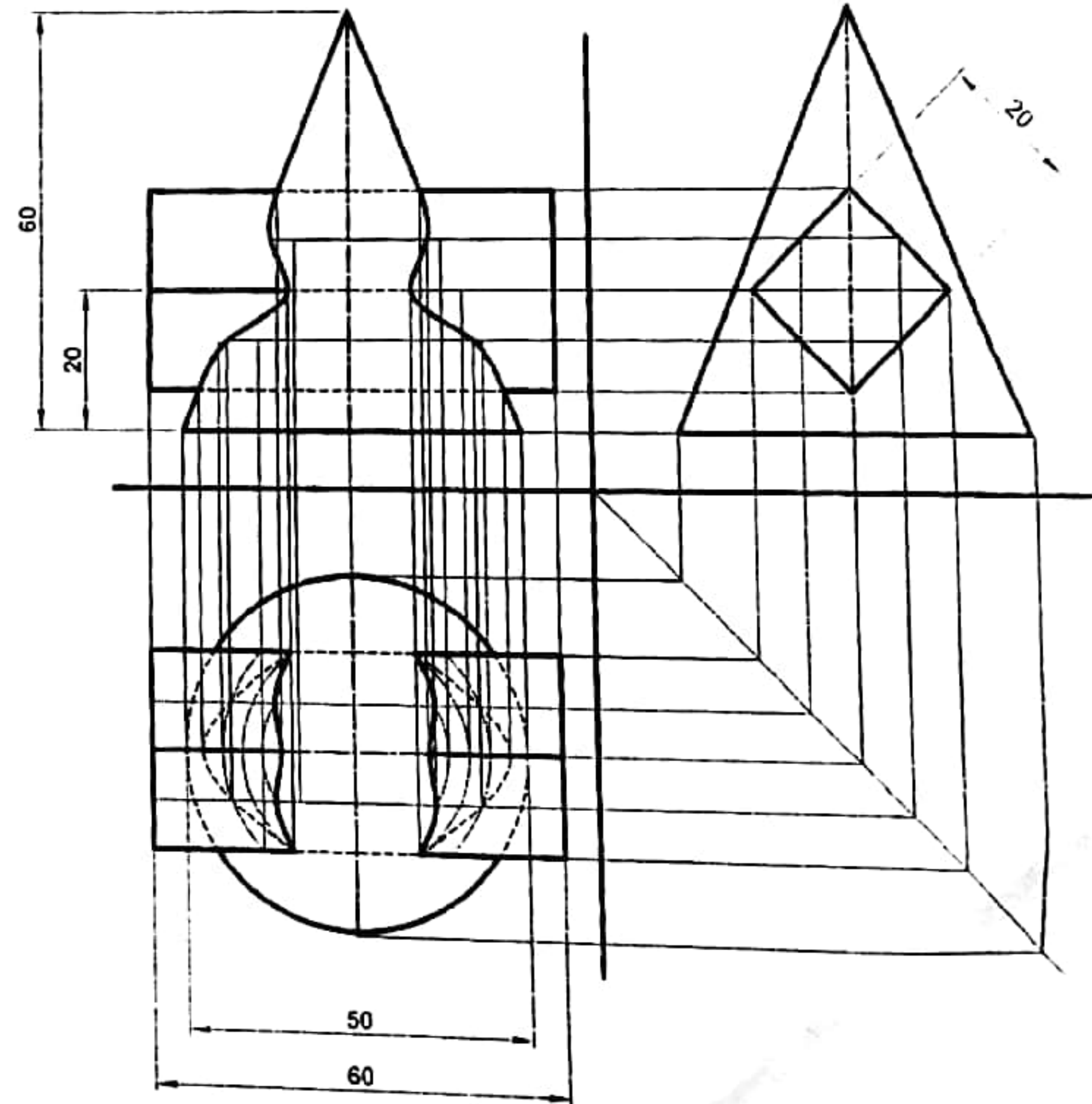

TOP VIEW

TRIBHUVAN UNIVERSITY INSTITUTE OF ENGINEERING THAPATHALI CAMPUS MAITIGHAR, KATHMANDU	SUBJECT	TITLE	DRAWN BY	CHECKED BY	DATE	SCALE
	ENGINEERING DRAWING	INTERSECTION OF TWO SOLIDS (INTERSECTION OF TWO SURFACES)	NAME ROLL NO	DATE	DRAWING NO	94

FRONT VIEW

LEFT SIDE VIEW

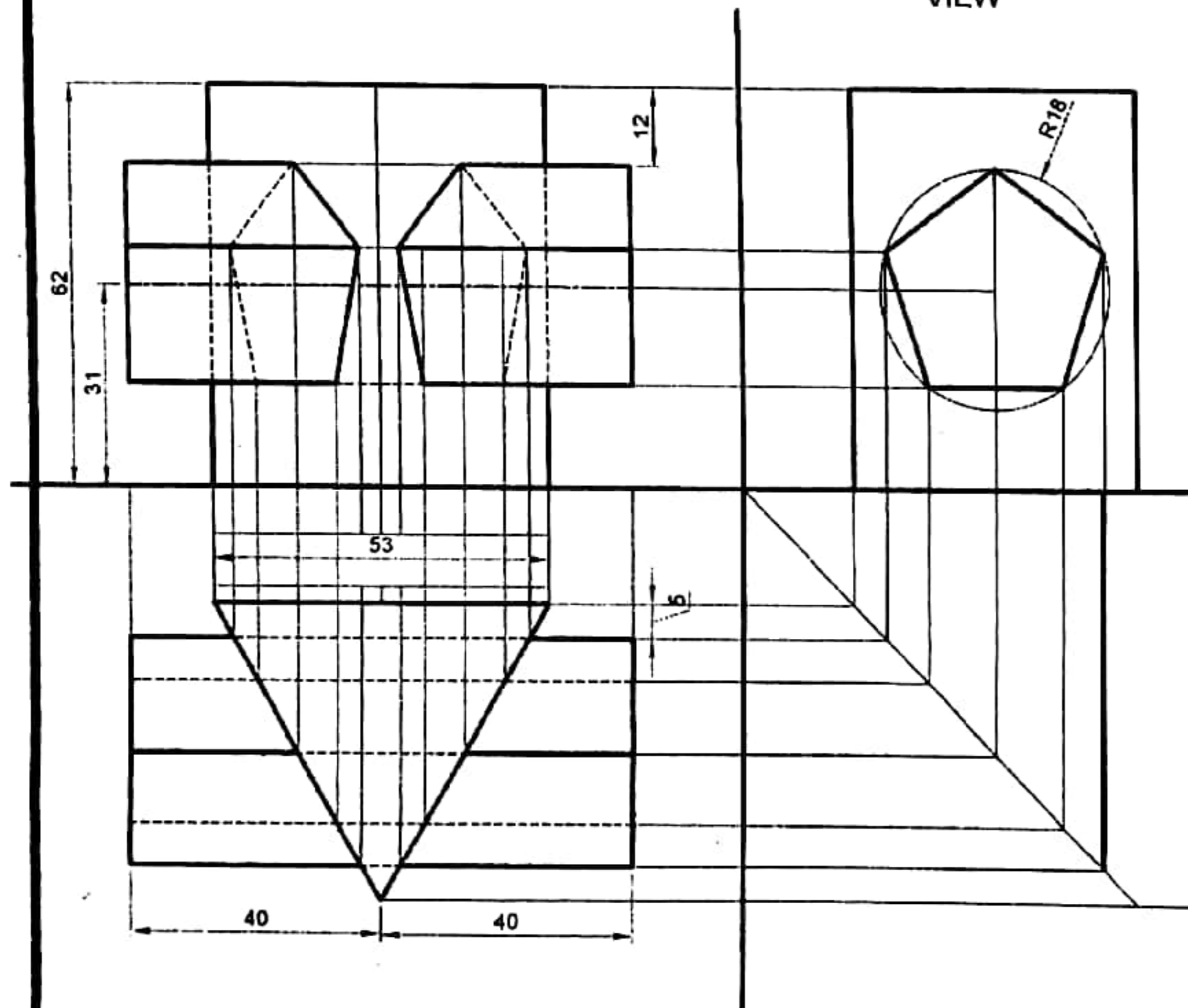

TOP VIEW

FRONT VIEW

LEFT SIDE VIEW

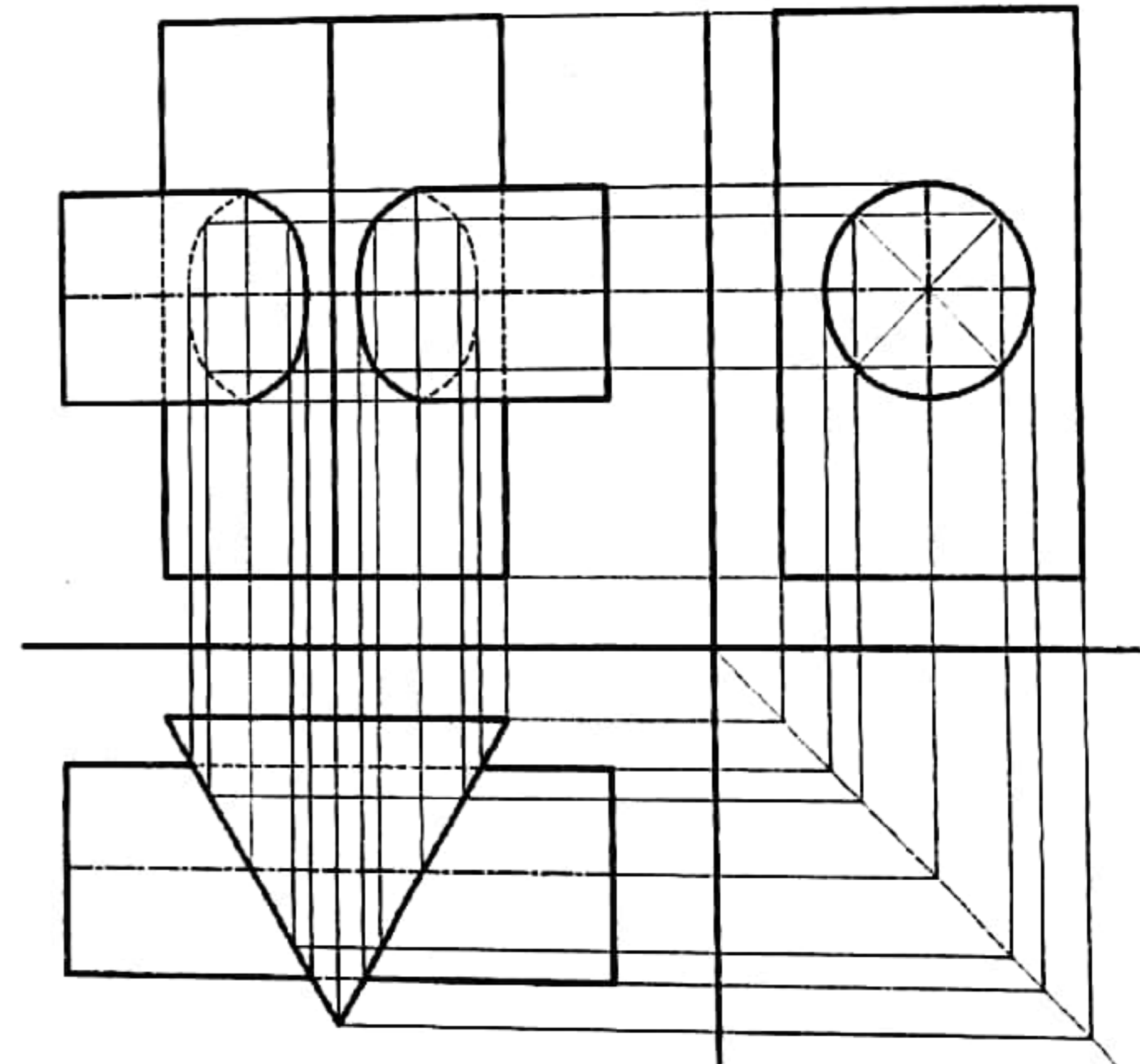

TOP VIEW

TOP VIEW

TRIBHUVAN UNIVERSITY INSTITUTE OF ENGINEERING THAPATHALI CAMPUS MAITIGHAR, KATHMANDU	SUBJECT	TITLE	DRAWN BY	CHECKED BY	DATE	SCALE
	ENGINEERING DRAWING	INTERSECTION OF TWO SOLIDS (INTERSECTION OF TWO SURFACES)	NAME ROLL NO	DATE	DRAWING NO	95

FRONT VIEW

LEFT SIDE VIEW

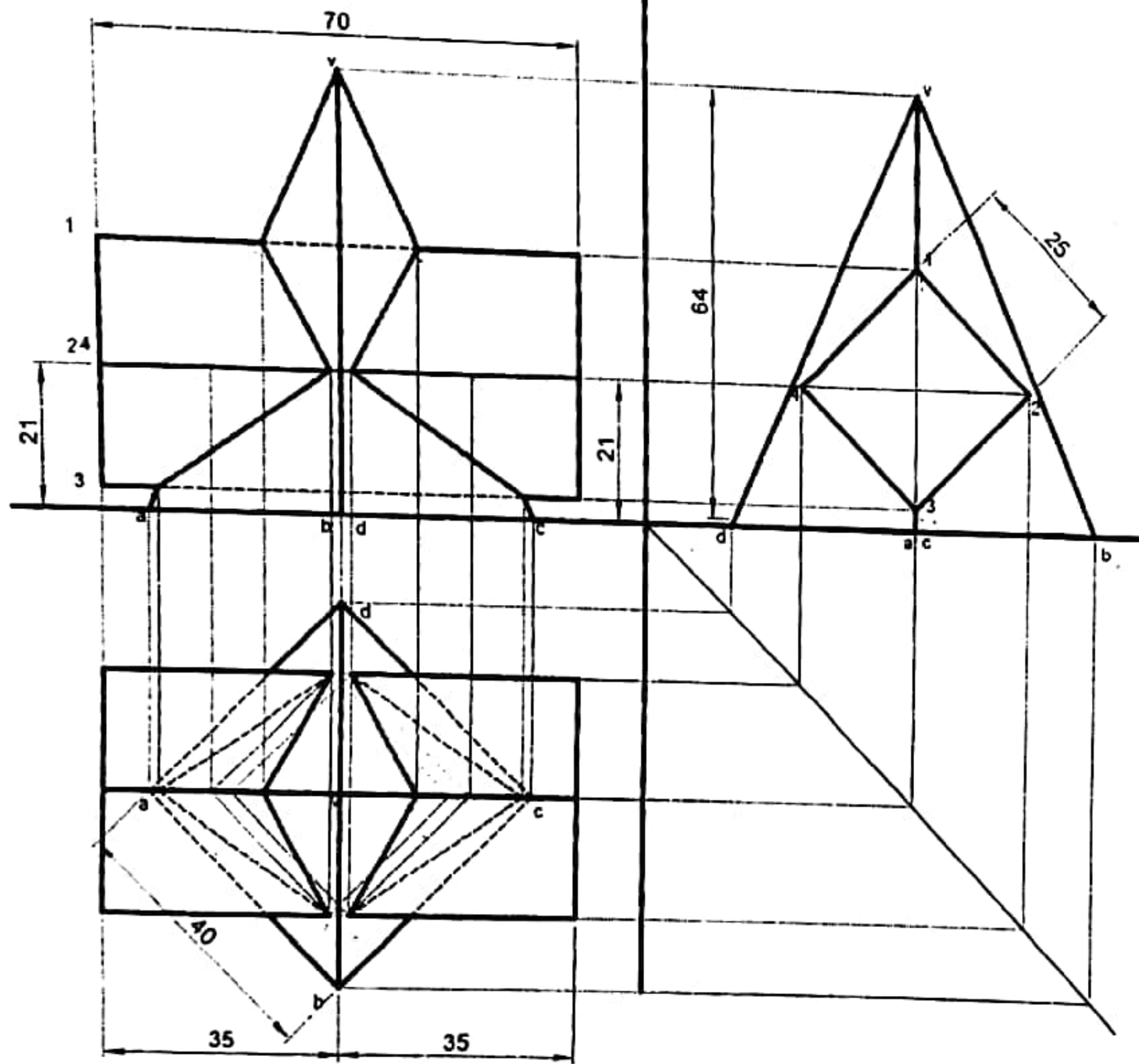

TOP VIEW

INTERSECTION OF RIGHT AND HORIZONTAL PRISMS
(INTERSECTION OF RIGHT AND HORIZONTAL PRISMS' SURFACES (axes of two PRISM are not coincided))

FRONT VIEW

LEFT SIDE VIEW

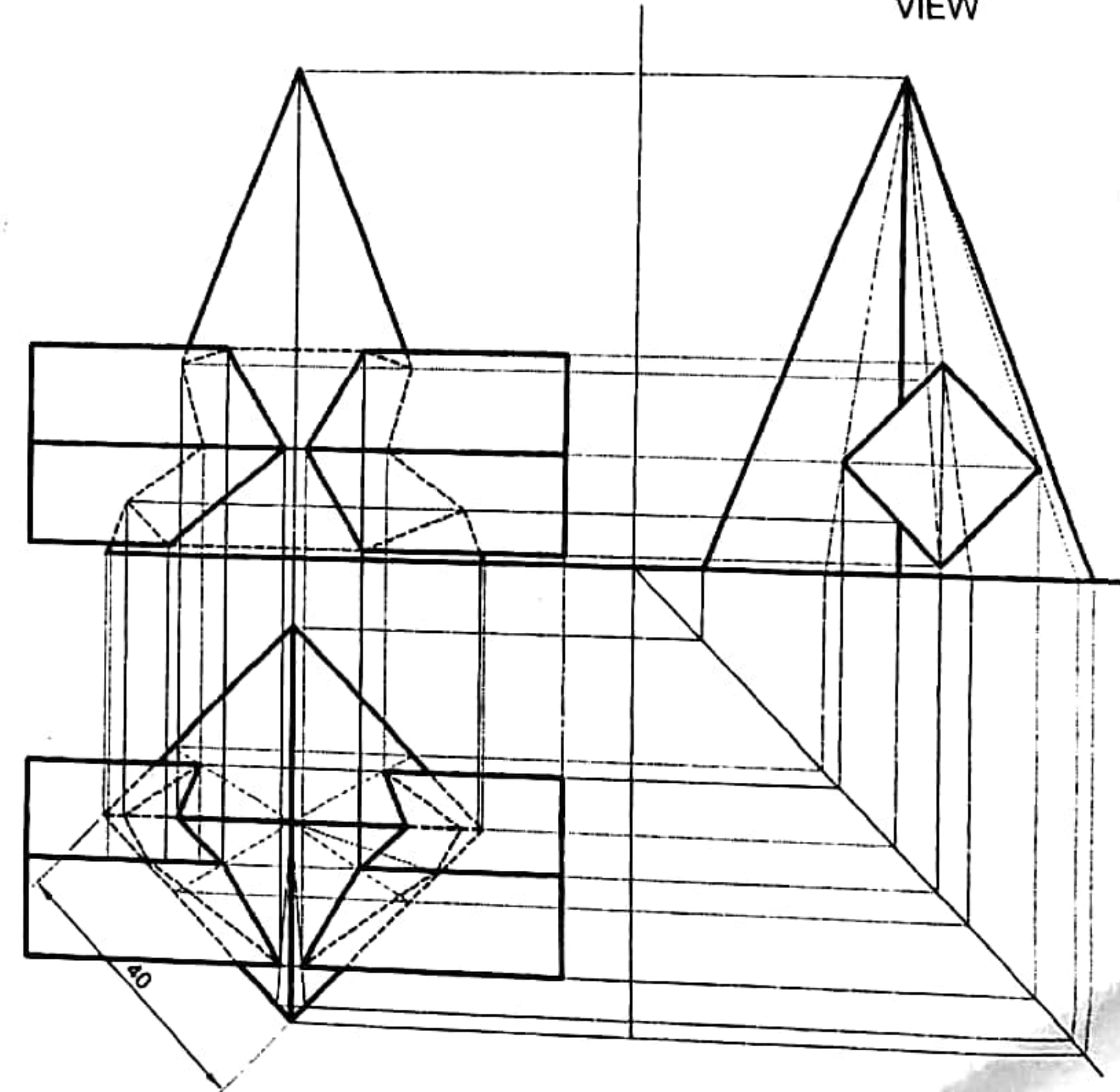

INTERSECTION OF RIGHT AND HORIZONTAL PRISMS
(INTERSECTION OF RIGHT AND HORIZONTAL PRISMS' SURFACES (axes of two PRISM are not coincided))

TRIBHUVAN UNIVERSITY INSTITUTE OF ENGINEERING THAPATHALI CAMPUS MAITIGHAR, KATHMANDU	SUBJECT ENGINEERING DRAWING	TITLE INTERSECTION OF TWO SOLIDS (INTERSECTION OF TWO SURFACES)	DRAWN BY NAME ROLL NO	CHECKED BY	DATE	SCALE
					DATE	DRAWING NO 96

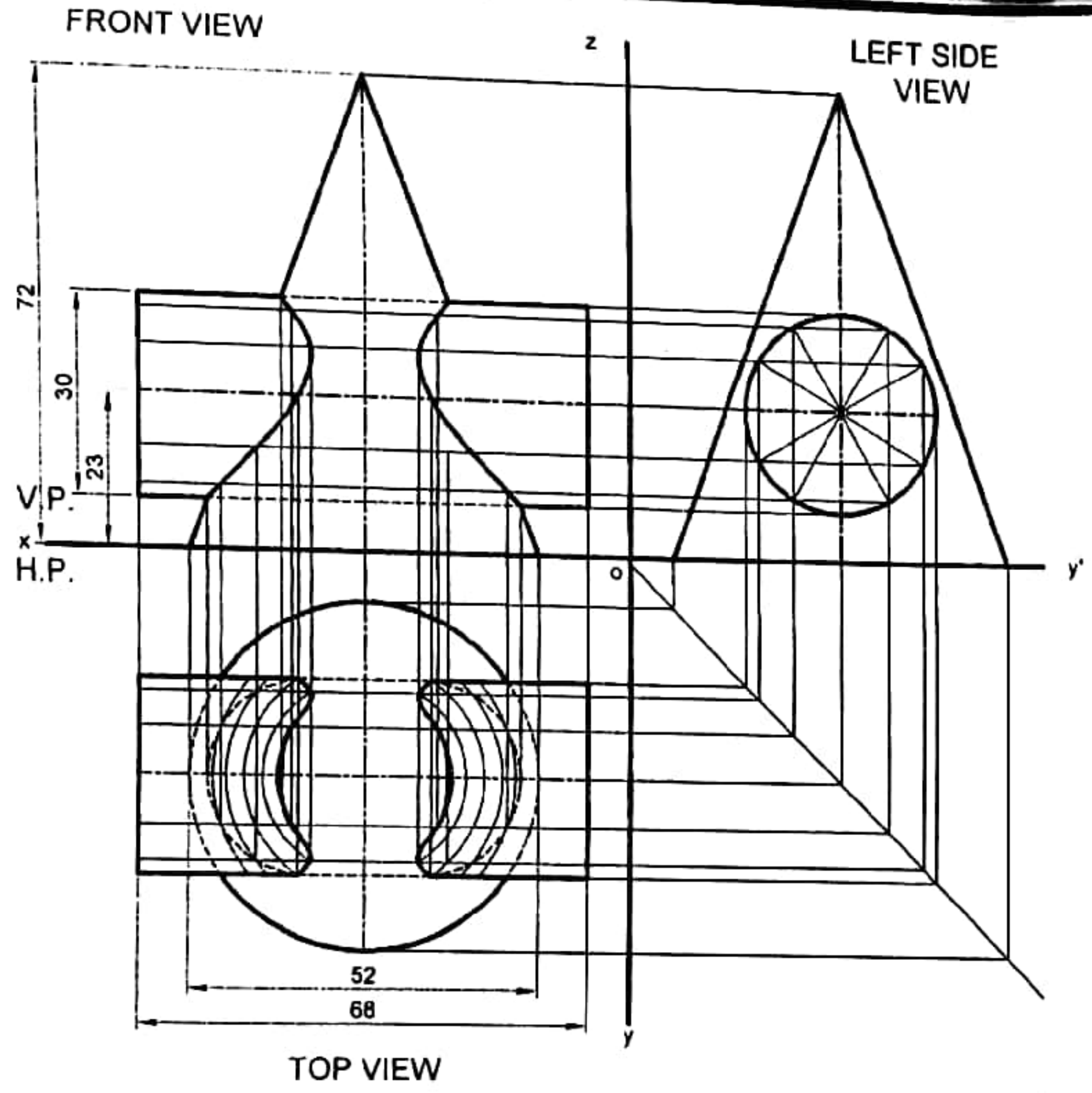

TOP VIEW

INTERSECTION BETWEEN RIGHT CONE AND HORIZONTAL CYLINDER

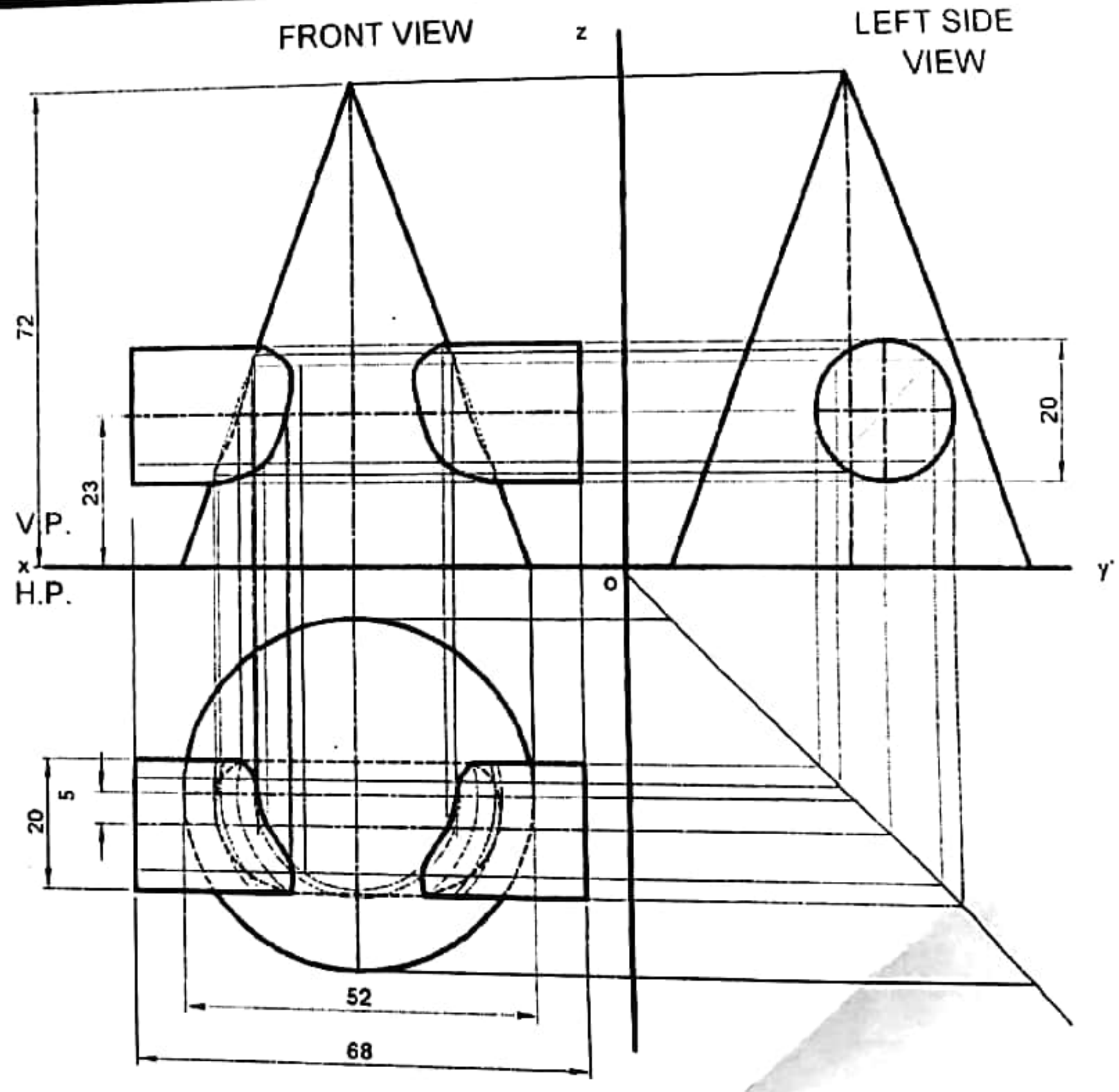

TOP VIEW

A right cone of base 52 mm diameter and axial height 72 mm is resting on HP by its base. It is completely penetrated by a horizontal cylinder of 30 mm diameter, such that both axes intersect each other at right angles, the axis of cylinder is parallel to VP and passing through the axis 23 mm above the base of cone. Draw the projection showing the curve of intersection.

A right cone of base 52 mm diameter and axial height 72 mm is resting on HP by its base. It is completely penetrated by a horizontal cylinder of 20 mm diameter, the axis of penetrated cylinder is parallel to VP and 23 mm above the base and 5 mm in front of the cone axis. Draw the projections of solids showing the curve of intersection (showing the seen and unseen).

TRIBHUVAN UNIVERSITY INSTITUTE OF ENGINEERING THAPATHALI CAMPUS MAITIGHAR, KATHMANDU	SUBJECT	TITLE	DRAWN BY	CHECKED BY	DATE	SCALE
	ENGINEERING DRAWING	INTERSECTION OF TWO SOLIDS (INTERSECTION OF TWO SURFACES)	NAME ROLL NO	DATE	DRAWING NO 97	

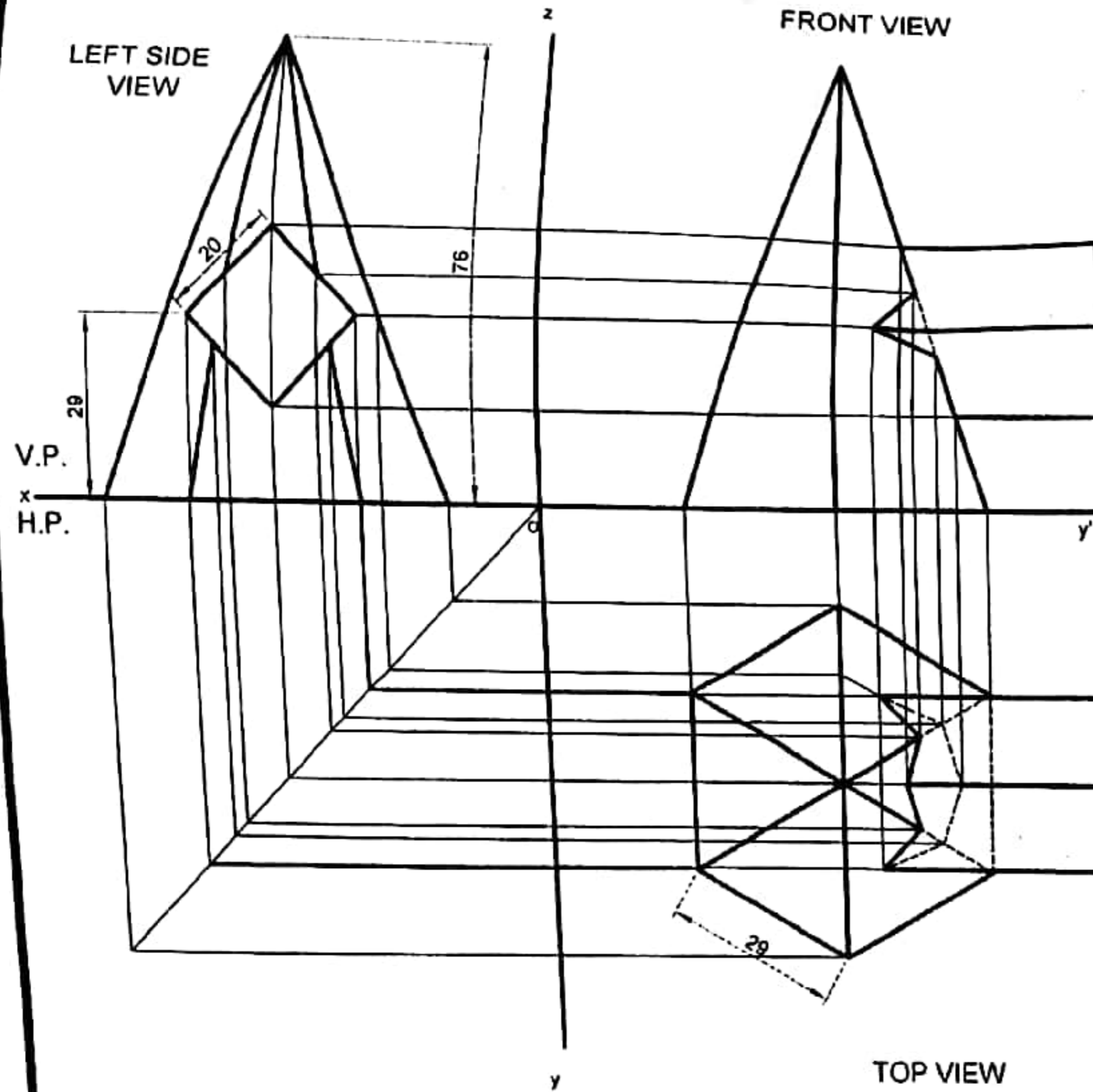

INTERSECTION BETWEEN RIGHT HEXAGONAL BASE PYRAMID AND HORIZONTAL SQUARE BASE PRISM

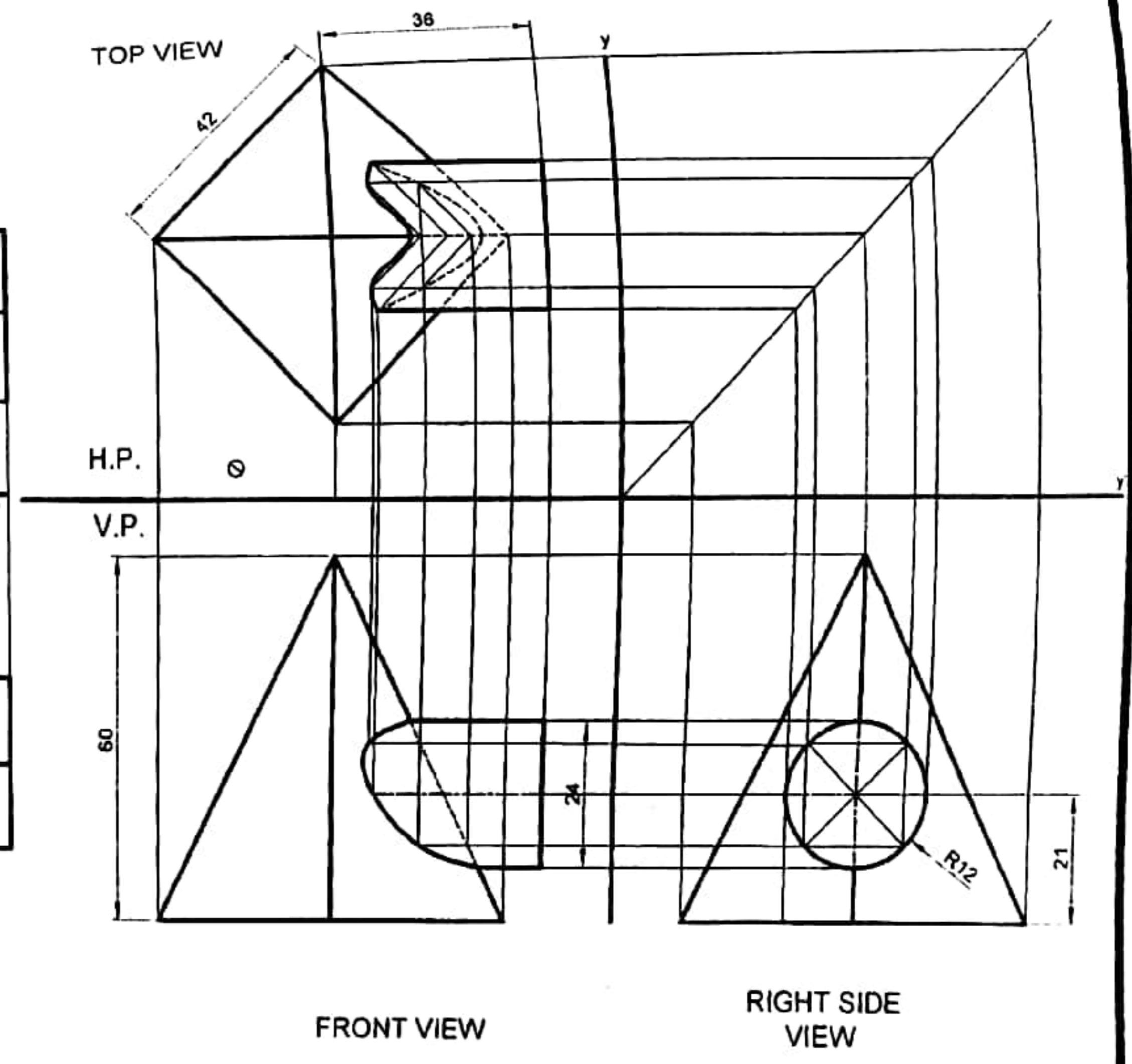

INTERSECTION BETWEEN RIGHT SQUARE BASE PYRAMID AND HORIZONTAL CYLINDER

TRIBHUVAN UNIVERSITY INSTITUTE OF ENGINEERING THAPATHALI CAMPUS MAITIGHAR, KATHMANDU	SUBJECT ENGINEERING DRAWING	TITLE INTERSECTION OF TWO SOLIDS (INTERSECTION OF TWO SURFACES)	DRAWN BY NAME ROLL NO	CHECKED BY DATE	DATE SCALE	DRAWING NO 98

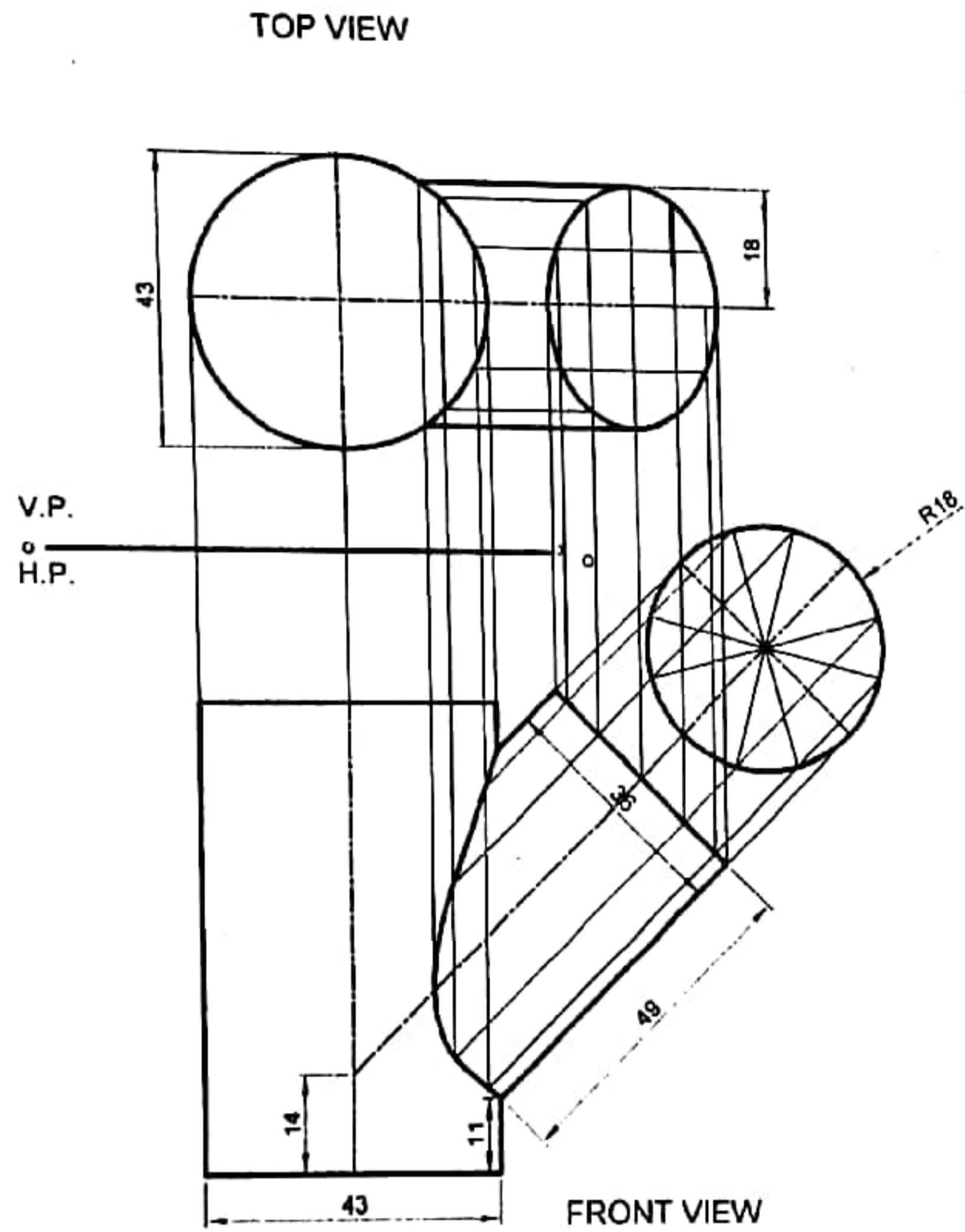

INTERSECTION BETWEEN RIGHT AND INCLINED CYLINDER

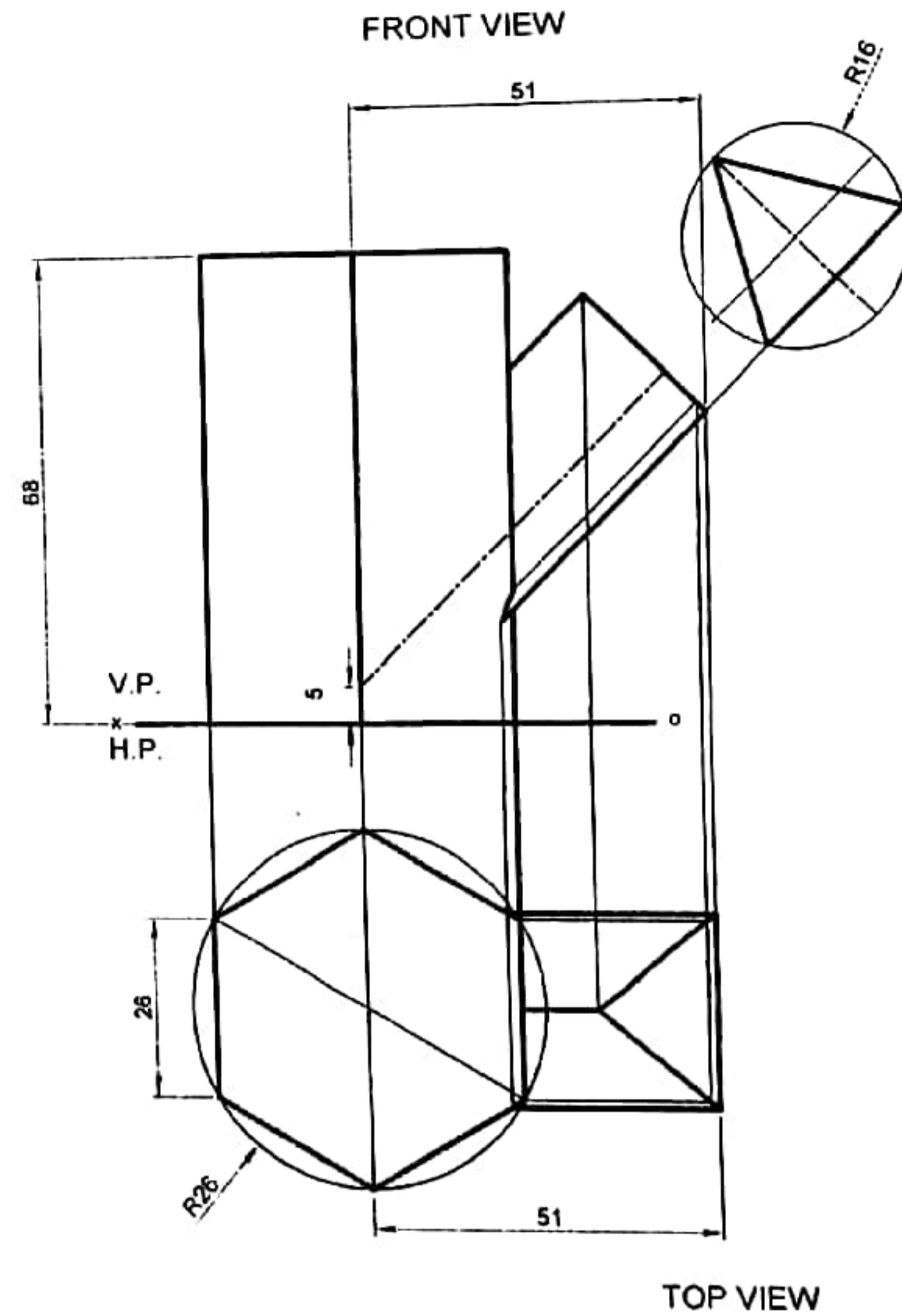

INTERSECTION BETWEEN RIGHT HEXAGONAL PRISM AND INCLINED TRIANGULAR PRISM

TRIBHUVAN UNIVERSITY INSTITUTE OF ENGINEERING THAPATHALI CAMPUS MAITIGHAR, KATHMANDU	SUBJECT	TITLE	DRAWN BY	CHECKED BY	DATE	SCALE
	ENGINEERING DRAWING	INTERSECTION OF TWO SOLIDS (INTERSECTION OF TWO SURFACES)	NAME ROLL NO	DATE	DRAWING NO	99

FRONT VIEW

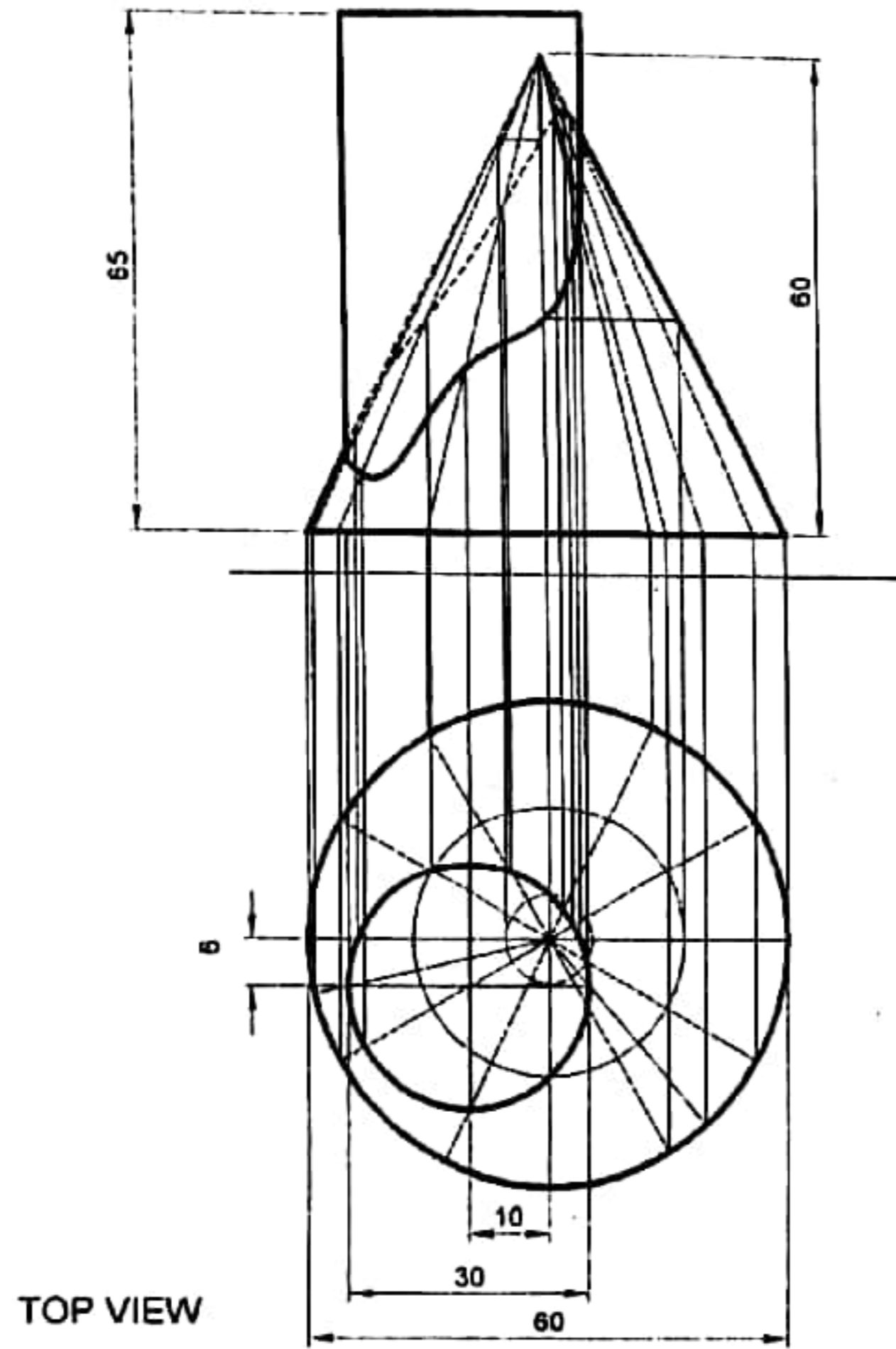

TOP VIEW

INTERSECTION OF VERTICAL CYLINDER AND RIGHT (VERTICAL) CONE

FRONT VIEW

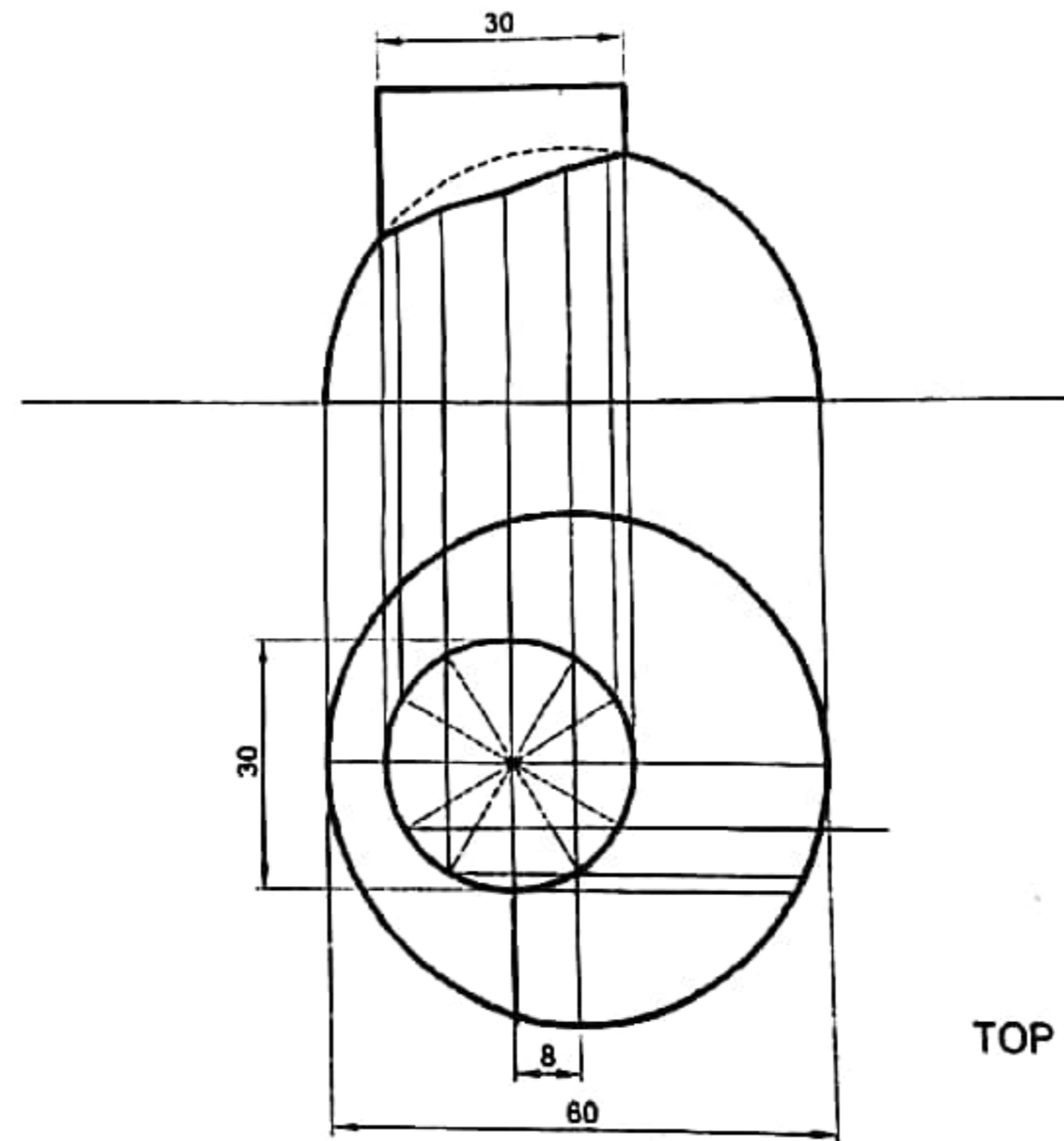

TOP VIEW

INTERSECTION OF VERTICAL CYLINDER AND HEMISPHERE

TRIBHUVAN UNIVERSITY INSTITUTE OF ENGINEERING THAPATHALI CAMPUS MAITIGHAR, KATHMANDU	SUBJECT	TITLE	DRAWN BY	CHECKED BY	DATE	SCALE
	ENGINEERING DRAWING		NAME ROLL NO	DATE	DRAWING NO	100