

TABLE OF CONTENTS – PIER DETAILS

CHAPTER 15

FILE NO.	TITLE	DATE
TABLE OF CONTENTS		
15.TOC-1	Table of Contents – Chapter 15	30Oct2020
15.TOC-2	Table of Contents – Chapter 15	30Oct2020
15.TOC-3	Table of Contents – Chapter 15	30Oct2020
15.00	Introduction.....	30Apr2020

GENERAL GUIDELINES AND TYPE SELECTION

15.01-1	General Guidelines.....	30Apr2020
15.01-2	General Guidelines.....	30Oct2020
15.01-3	General Guidelines.....	18May2016
15.01-4	Virginia Pier Cap	30Oct2020
15.01-5	Virginia Pier Cap (Special Circumstances)	30Apr2020
15.01-6	Type Selection.....	30Oct2020
15.01-7	Geotechnical Design Data Tables and Architectural Treatment for Piers	30Oct2020

PIER COMPONENTS AND MISCELLANEOUS DETAILS

15.02-1	Cap/Column Clearance/Long Chord Layout	30Apr2019
15.02-2	Cap Length Criteria	30Apr2020
15.02-3	Beam-Column Corner Reinforcing	30Apr2020
15.02-4	Beam-Column Corner Reinforcing	30Apr2020
15.02-5	Sample Anchor Bolt Layouts	27Jul2017
15.02-6	Bottom Cap Slope and Cap Reinforcement	18May2016
15.02-7	Cap Reinforcement	18May2016
15.02-8	Seat Reinforcement.....	30Apr2020
15.02-9	Columns	30Apr2020
15.02-10	Columns	18May2016
15.02-11	Column Ties	18May2016
15.02-12	Footing Types and Details	30Apr2020
15.02-13	Drilled Shafts	30Oct2020
15.02-14	Drilled Shafts	18May2016
15.02-15	Drilled Shafts	30Oct2020

SAMPLE SHEETS AND DETAILING CHECK LIST

* 15.03-1	Sample Multi-Column Pier Sheet	30Apr2020
* 15.03-2	Sample Hammerhead Pier Sheet	30Apr2020

* Indicates 11 x 17 sheet; all others are 8½ x 11.

PIER DETAILS TABLE OF CONTENTS – CHAPTER 15

PART 2
DATE: 30Oct2020
SHEET 1 of 3
FILE NO. 15.TOC-1

TABLE OF CONTENTS – PIER DETAILS

CHAPTER 15

FILE NO.	TITLE	DATE
SAMPLE SHEETS AND DETAILING CHECK LIST (Continued)		
* 15.03-3	Sample Hammerhead Pier Sheet	30Apr2020
* 15.03-4	Sample Wall Pier Sheet	30Apr2020
* 15.03-5	Sample Pile Bent Sheet	30Apr2020
15.03-6	Check List.....	30Apr2020
15.03-7	Check List.....	30Apr2020
* 15.03-8	Sample Virginia Pier Sheet	30Apr2020
* 15.03-9	Sample Virginia Pier Sheet	30Apr2020
* 15.03-10	Sample Virginia Pier Sheet	30Apr2020
* 15.03-11	Sample Virginia Pier Sheet	30Apr2020
15.03-12	Check List.....	30Apr2020

SUPERSTRUCTURE FORCES

15.04-1	General Information.....	30Oct2020
15.04-2	General Information.....	11Jan2011
15.04-3	General Information.....	17Dec2010
15.04-4	Example 1: Varying Height/Stiffness.....	11Jan2011
15.04-5	Example 1: Varying Height/Stiffness.....	11Jan2011
15.04-6	Example 1: Varying Height/Stiffness.....	11Jan2011
15.04-7	Example 2: Unsymmetric Spans	17Dec2010
15.04-8	Example 2: Unsymmetric Spans	11Jan2011
15.04-9	Example 3: Pile Bent.....	17Dec2010
15.04-10	Example 3: Pile Bent.....	11Jan2011
15.04-11	Example 3: Pile Bent.....	11Jan2011
15.04-12	Example 3: Pile Bent.....	11Jan2011

SECTION 15.05 intentionally left blank

PIER PROTECTION SYSTEM

15.06-1	General Information.....	18May2016
15.06-2	General Information.....	30Oct2020
15.06-3	General Information.....	18May2016
15.06-4	Length of Pier Protection.....	18May2016
15.06-5	Length of Pier Protection.....	18May2016
15.06-6	Length of Pier Protection.....	18May2016
15.06-7	Length of Pier Protection.....	18May2016
15.06-8	Barrier Layout Example 1	18May2016
15.06-9	Barrier Layout Example 2	30Oct2020
15.06-10	Barrier Layout Example 2.....	30Oct2020

* Indicates 11 x 17 sheet; all others are 8½ x 11.

TABLE OF CONTENTS – PIER DETAILS

CHAPTER 15

FILE NO.	TITLE	DATE
PIER PROTECTION SYSTEM (Continued)		
15.06-11	Barrier Layout Example 3.....	30Oct2020
15.06-12	Barrier Layout Example 3.....	18May2016
15.06-13	Barrier Layout Example 3.....	30Oct2020
15.06-14	Barrier Layout Example 4.....	18May2016
15.06-15	Barrier Layout Example 4.....	30Oct2020
15.06-16	Barrier Layout Example 4.....	30Oct2020
15.06-17	Barrier Layout Example 5.....	30Oct2020
15.06-18	Barrier Layout Example 5.....	30Oct2020
15.06-19	Barrier Layout Example 5.....	30Oct2020

INTRODUCTION

Piers transmit loads from the superstructure to the foundation.

The intent of this chapter is to establish the practices and specific requirements of the Structure and Bridge Division for the design and detailing of piers and pile bents.

It is expected that users of this chapter will adhere to the practices and requirements stated herein. A design waiver will be required for areas that are indicated as "minimum" standards or where the term "shall" is indicated. The designer shall be responsible for investigation, analysis and calculations necessary to secure a waiver from the State Structure and Bridge Engineer. The designer must indicate in the waiver why the standard cannot be met.

References to AASHTO LRFD Specifications refer to the current AASHTO LRFD Bridge Design Specifications and current VDOT Modifications (IIM-S&B-80).

NOTE:

Due to various restrictions on placing files in this manual onto the Internet, portions of the drawings shown do not necessarily reflect the correct line weights, line types, fonts, arrowheads, etc. Wherever discrepancies occur, the written text shall take precedence over any of the drawn views.

GENERAL INFORMATION:

Specific types of piers and details are more cost effective or necessary due to aspects of the particular bridge grade and location. In general, it is beneficial to keep cap size, column size and pile type and size the same for all piers/bents on a project and/or corridor to enable the reuse of forms and to avoid ordering small quantities. On larger projects, additional column sizes or pile types may be warranted where heights, depths or design loads vary substantially across the spans.

Drainage: See File No. 22.04-2 for criteria on downspout / collector pipe placement.

Multi-Column Piers:

Multi-column piers are typically used where column heights are below 30 feet. Column spacing between 15 and 20 feet is generally cost effective. Cap ends shall not be rounded, but should be tapered for aesthetic purposes. Concrete Class A3 ($f'_c = 3,000$ psi) should be used. Class A4 ($f'_c = 4,000$ psi) may be used where warranted. The use of multi-column piers in areas where floating debris may lodge between columns should be avoided.

On wide structures with more than five columns and/or cap lengths greater than 80 feet, designers should consider whether to split a multi-column pier into two piers especially where columns are short and contraction/expansion of the pier cap results in large internal forces. For piers with more than six columns and/or cap lengths greater than 100 feet, two piers are required.

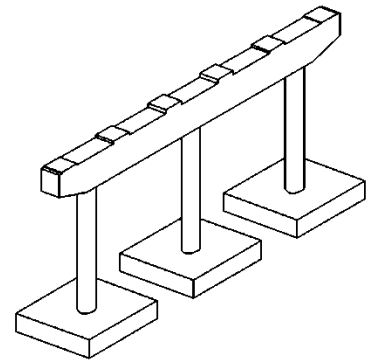

Hammerhead Piers:

Hammerhead piers are typically used where column lengths on multi-column piers will require larger column sizes due to slenderness. Hammerhead piers are also an option where stream flow could result in debris build-up between columns of a multi-column pier.

Where stream flow is present, hammerhead piers shall be oriented parallel to the direction of flow. Small skews to the direction of flow are acceptable (0 to 5 degrees) where superstructure skew can be eliminated completely or reduced for specific design purposes. Specific design purposes include reducing skew to 10 degrees so V-load method can be used to determine cross frame forces on steel superstructure and reducing skew to 20 degrees so finite element analysis is not required. Small skews parallel to the direction of flow require concurrence of the hydraulic engineer.

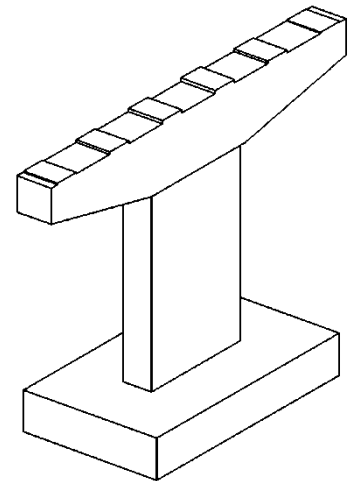

The design of hammerhead piers shall include a load case based on eccentric loads due to a future re-decking with half of the deck removed.

Wall/Solid Piers:

Wall piers are typically used where multi-column piers may be used, but stream flow will result in debris build-up between columns. Wall piers may be more cost effective than multi-column piers when collision force is taken into account.

GENERAL INFORMATION (continued):

Wall/Solid Piers (continued):

Concrete Class A3 ($f'_c = 3,000$ psi) shall be used. Sloped (tapered/battered) walls shall not be used. Non-reinforced walls are prohibited. Wall piers shall be oriented parallel to the direction of flow. Caps are required where the width of wall is not sufficient for bearing layout (typically where two bearing lines are present).

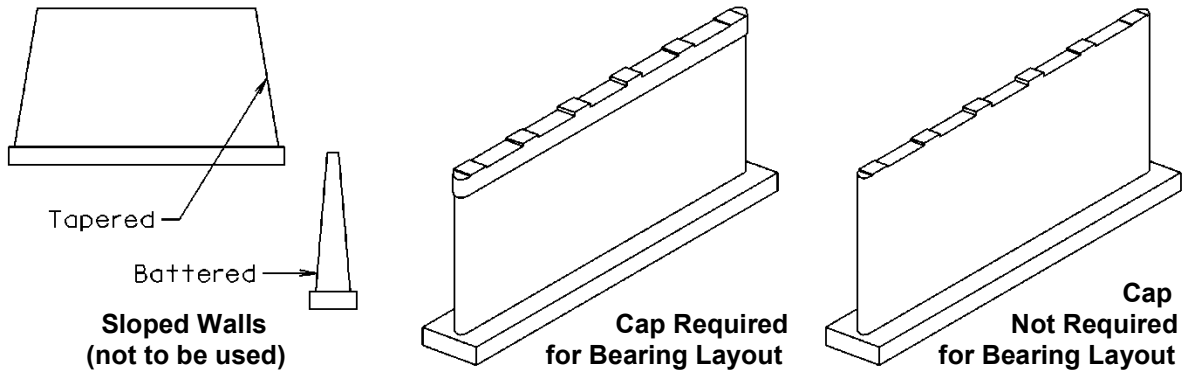

Pile Bents:

Pile bents are typically used over wetlands or bodies of water due to their lower cost and reduced environmental impact. However, they may not be suitable for tall piers. The only pile types allowed with pile bents are prestressed concrete square piles (from the BPP standards, with minimum size being 18") or prestressed concrete cylinder piles (DBE approval is needed for cylinder piles). Plumb piles are preferred. The outside pile on both sides of the bent may be battered to improve resistance to movement due to transverse forces only where future widening is not a concern. Likewise, piles may be battered longitudinally at a fixed bent or bents to better fix the thermal center of a unit and handle longitudinal forces. Batter on piles should not exceed 1:6. Before battering piles, designers should consider whether fixing more bents can adequately handle design loads and movement.

A pile bent shall not be used if more than 35' of pile is exposed above the ground line or water line (MHT).

Pile bents are often used in scorable areas. Designers must investigate both the existing ground and scoured condition as the assumed point of fixity for the piles can vary substantially. Additionally, pile driveability must be evaluated. The designers must determine if a pile can be driven deep enough so that it is stable after scour occurs. Assuming the number of piles equals the number of beam lines is a good starting point for preliminary design.

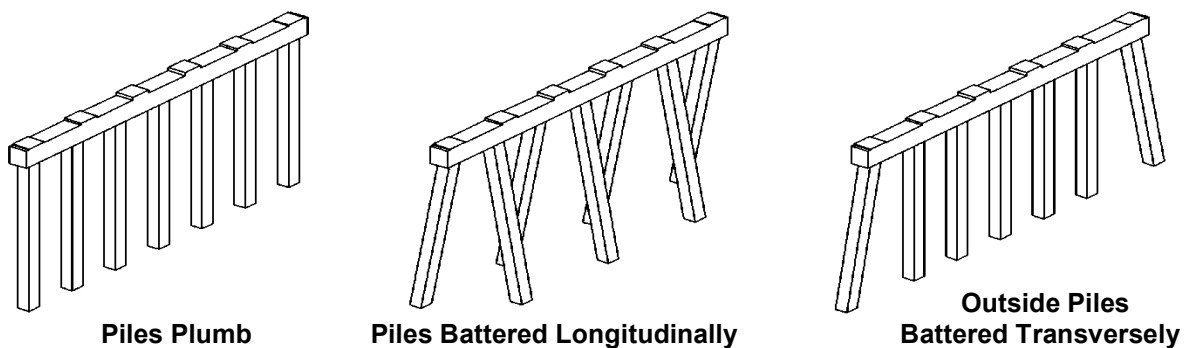

PIER DETAILS GENERAL GUIDELINES AND TYPE SELECTION GENERAL GUIDELINES

PART 2
DATE: 30Oct2020
SHEET 2 of 7
FILE NO. 15.01-2

GENERAL INFORMATION (continued):

Straddle Bents:

Straddle bents are typically used where column/footing placement would interfere with the road below (e.g. ramp flyovers).

Straddle bents are non-redundant structures. In addition, steel straddle bents are considered to be fracture critical.

Post-tensioned concrete straddle bents are not permitted.

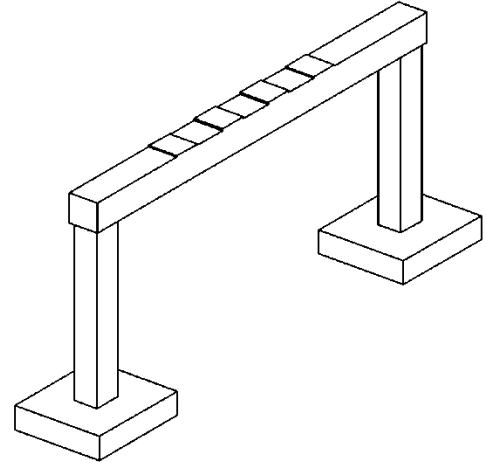

Integral Caps:

Integral caps are used where finished grade limitations on the structure provide insufficient vertical clearance above the underpass. Steel integral caps are considered fracture critical including a two-stringer transverse cap system where each stringer is designed to carry all forces independently.

Note that the deck was cut at the near face of integral cap for clarity for concrete example. Deck not shown for two-stringer transverse cap system example. Parapet not shown.

Post-tensioned concrete integral caps are not permitted.

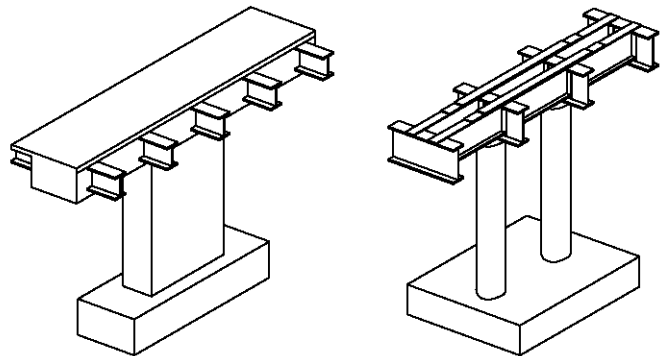

Integral Straddle Bents:

Integral straddle bents are used where column/footing placement would interfere with the road below (e.g. ramp flyovers) and finished grade limitations on the structure provide insufficient vertical clearance above the underpass.

Integral straddle bents are non-redundant structures. In addition, steel integral straddle bents are considered to be fracture critical.

Note that the deck was cut at the near face of integral straddle cap for clarity. Parapet not shown.

Post-tensioned concrete integral straddle bents are not permitted.

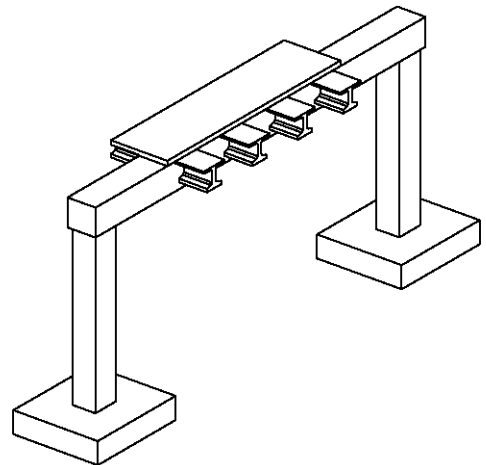

VIRGINIA PIER CAP:

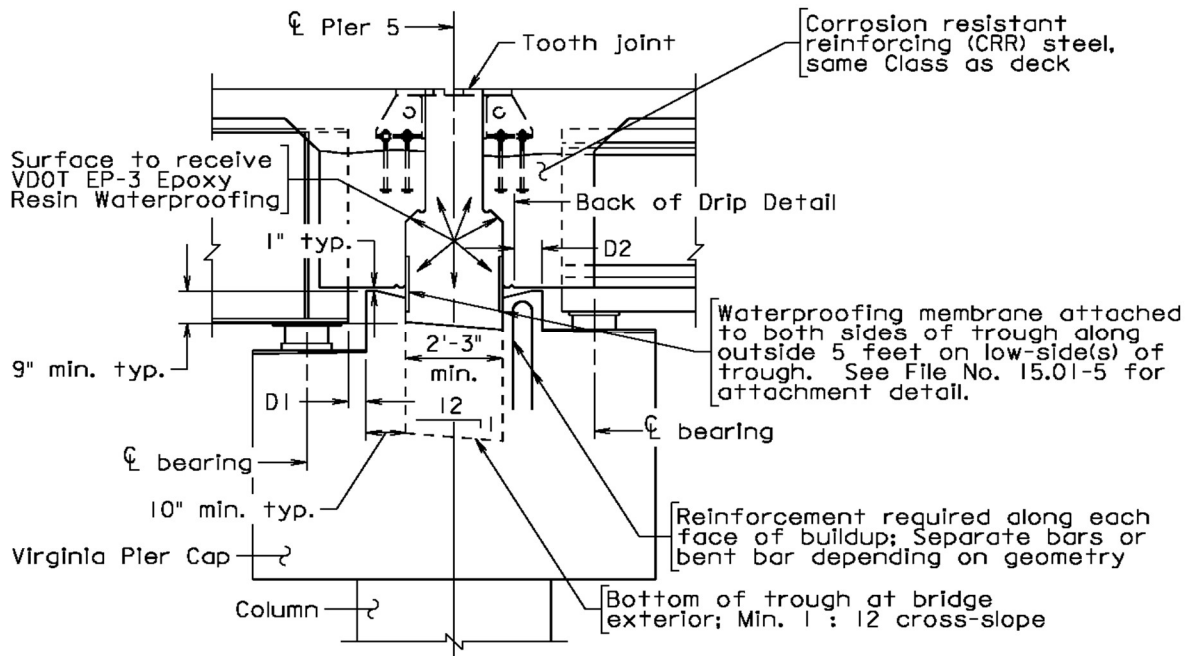

When a joint is introduced at a pier/bent, a design waiver approved by the State Structure and Bridge Engineer is required and the Virginia Pier Cap shall be used. As part of the design waiver request, the designer must address the type of joint and, if a tooth joint is planned, the alignment of the teeth (this is particularly important for curved structures where the longitudinal movement will likely have a transverse component). Locating a tooth joint at a pier of a curved structure is strongly discouraged. See File 17.01-9 thru -13 for information pertaining to abutment type selection and jointless philosophy.

The minimum embedment into the concrete integral backwall shall be 6" for steel stringers and 9" for concrete stringers.

Distance between end of beam/girder and buildup (D1) shall provide a minimum of 1" clearance at maximum expansion. The buildup shall be of sufficient width to provide a minimum of 3" beyond the back of drip details with superstructure at maximum contraction and shrinkage, where applicable, (D2). The top of buildup below the drip bead shall be sloped, but the top can also be sloped full width. The top slope shall drop a minimum of 2".

The Designer shall work with the District to determine the minimum trough depth sufficient for manual cleanout. Where beam/girder depths are shallower, additional cap depth may be necessary to ensure the minimum trough depth and cross-slope are maintained.

The Designer shall include anticipated construction loading in design of the pier (e.g., steel erected on one side only, steel erected on both sides with deck cast on one side only, etc.).

The Designer shall include the following note in the plans: Forms for the backwall shall be attached to the girders only; the forms shall not be attached to or blocked against the cap or other backwall. The backwall and forms must be free to move in relation to the cap.

Tooth joints can capture large volumes of drainage and details for conveyance of drainage to the ground and erosion control need to be carefully considered. However, tooth joints are not to be considered part of the design of or eliminate the need for bridge deck drainage systems.

Any deviations from the conceptual layout or minimum dimensions indicated above require a design approval from the District Structure and Bridge Engineer.

PIER DETAILS GENERAL GUIDELINES AND TYPE SELECTION VIRGINIA PIER CAP

PART 2
DATE: 30Oct2020
SHEET 4 of 7
FILE NO. 15.01-4

VIRGINIA PIER CAP (SPECIAL CIRCUMSTANCES):

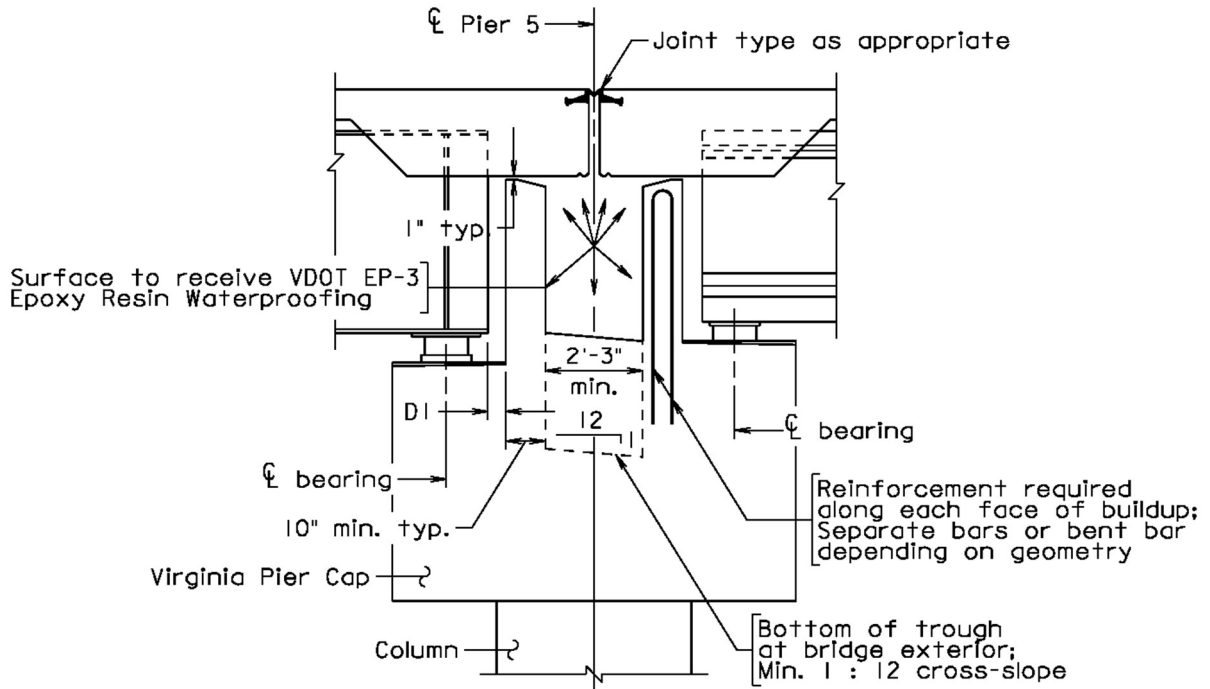

The Virginia Pier Cap details shown above are for special circumstances (e.g., gore area on bridge where ramps merge). See previous sheet for applicable notes.

WATERPROOFING MEMBRANE DETAIL FOR VIRGINIA PIER CAP:

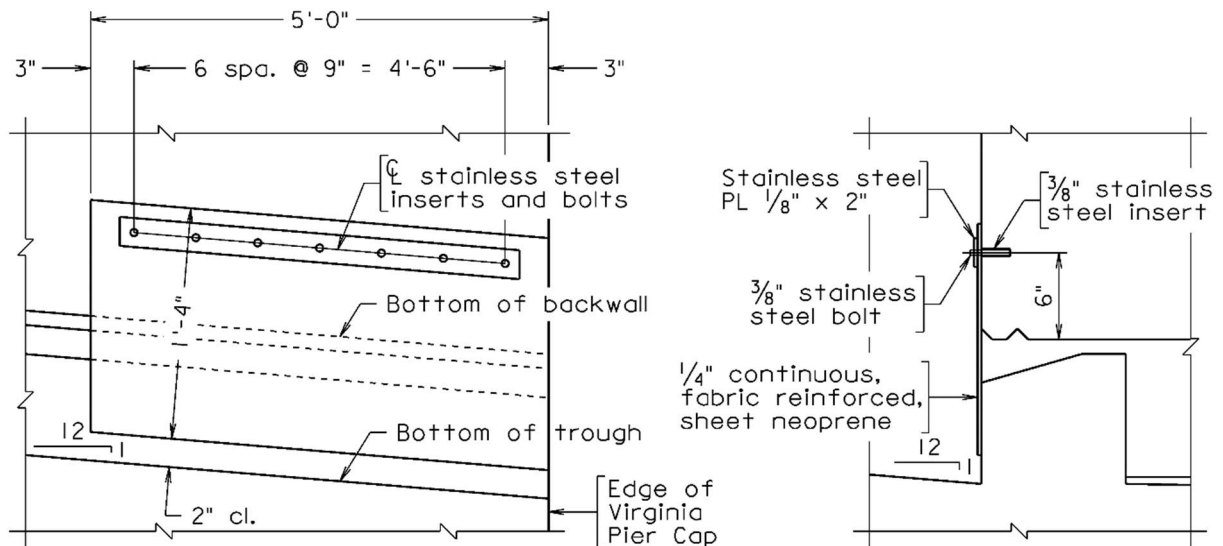

PIER DETAILS
GENERAL GUIDELINES AND TYPE SELECTION
VIRGINIA PIER CAP (SPECIAL CIRCUMSTANCES)

PART 2
 DATE: 30Apr2020
 SHEET 5 of 7
 FILE NO. 15.01-5

TYPE SELECTION:

This flowchart is provided to aid pier type selection. It is intended to provide general guidelines and to supplement 15.01-1 thru 15.01-3.

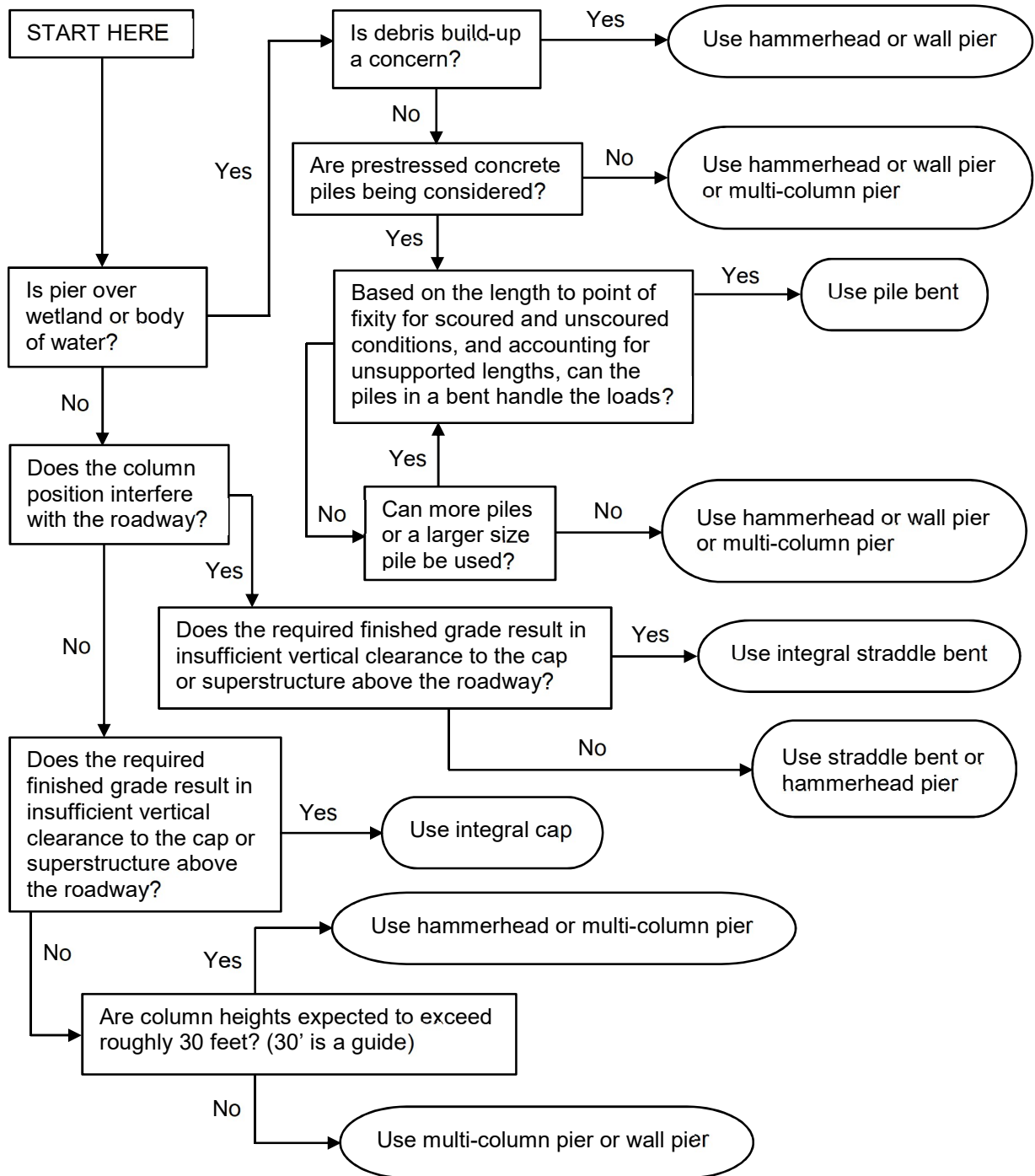

In all cases, see Section 15.06 if the horizontal clearance to face of pier will be less than 30 feet from edge of traffic lane.

GEOTECHNICAL DESIGN DATA TABLES:

The appropriate geotechnical design data table shall be provided either on pier and abutment sheets or on the sheet with the Substructure Layout. See File No. 23.01-8 for table to be used with pile foundations. See File No. 17.02-3 for tables to be used with spread footings or drilled shafts.

ARCHITECTURAL TREATMENT FOR PIERS

The decision to incorporate architectural treatment into a bridge project and the type of treatments shall be made during the preliminary design. Incorporating or removing architectural treatments from a project at a later stage could require re-design and plan changes including quantities.

Including architectural treatment on piers may affect geometric items such as horizontal clearances. Designers must consider the texture relief to be sacrificial and position reinforcement to provide the minimum concrete cover required from the back of the maximum relief used to the reinforcement. Copings may need additional reinforcement to be included in plan details. Architectural treatments such as sculpted windows and wall murals have minimum dimensions that need to be considered when sizing structural members (e.g., columns) where those treatments are desired.

See Chapter 5 of this manual for requirements, details and information for architectural treatment.

CAP/COLUMN CLEARANCE:

No portion of a cap or column on a double or triple overpass shall be within 4 feet clear of the top front face of parapet/rail extended 10 feet above the top of deck or protrude beyond the back of parapet/rail for the remaining distance to the required vertical clearance for the road classification as illustrated below. The same criterion applies to the cap or column for at-grade barriers except that that Standard BPPS series barrier may be located directly adjacent to the column.

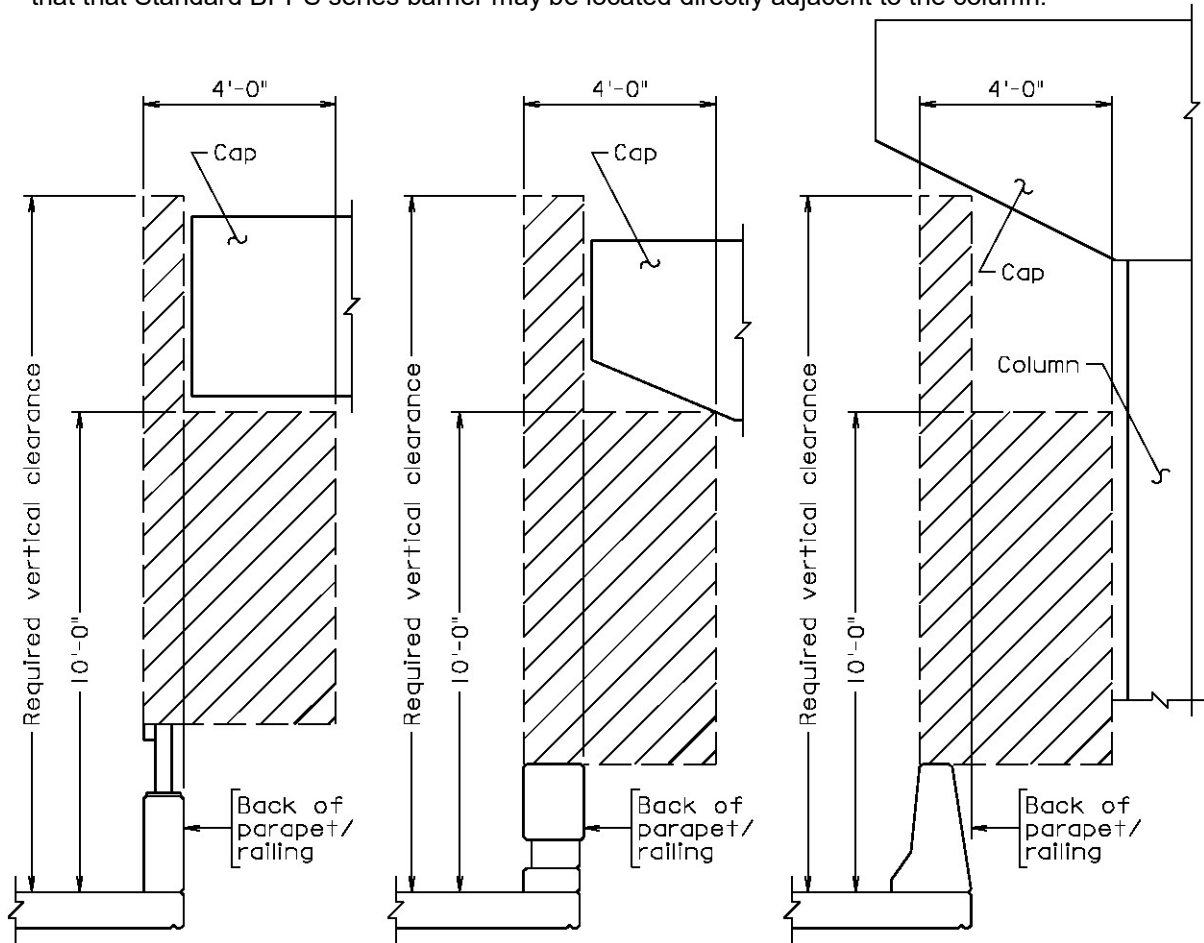

BRIDGE LAYOUT ON LONG CHORD:

Use details only if pier is laid out on the long chord. Details shown here must agree with BRIDGE LAYOUT and SUBSTRUCTURE LAYOUT shown on the plans.

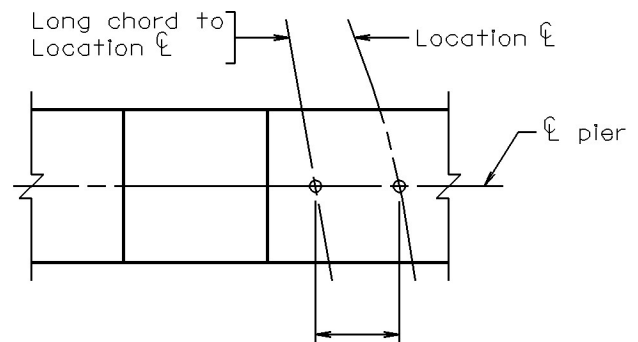

PART PLAN OF CAP
BRIDGE LAYOUT ON LONG CHORD

PIER DETAILS PIER COMPONENTS AND MISCELLANEOUS DETAILS CAP/COLUMN CLEARANCE / LONG CHORD LAYOUT

PART 2
DATE: 30Apr2019
SHEET 1 of 15
FILE NO. 15.02-1

CRITERIA FOR PIER CAP LENGTH:

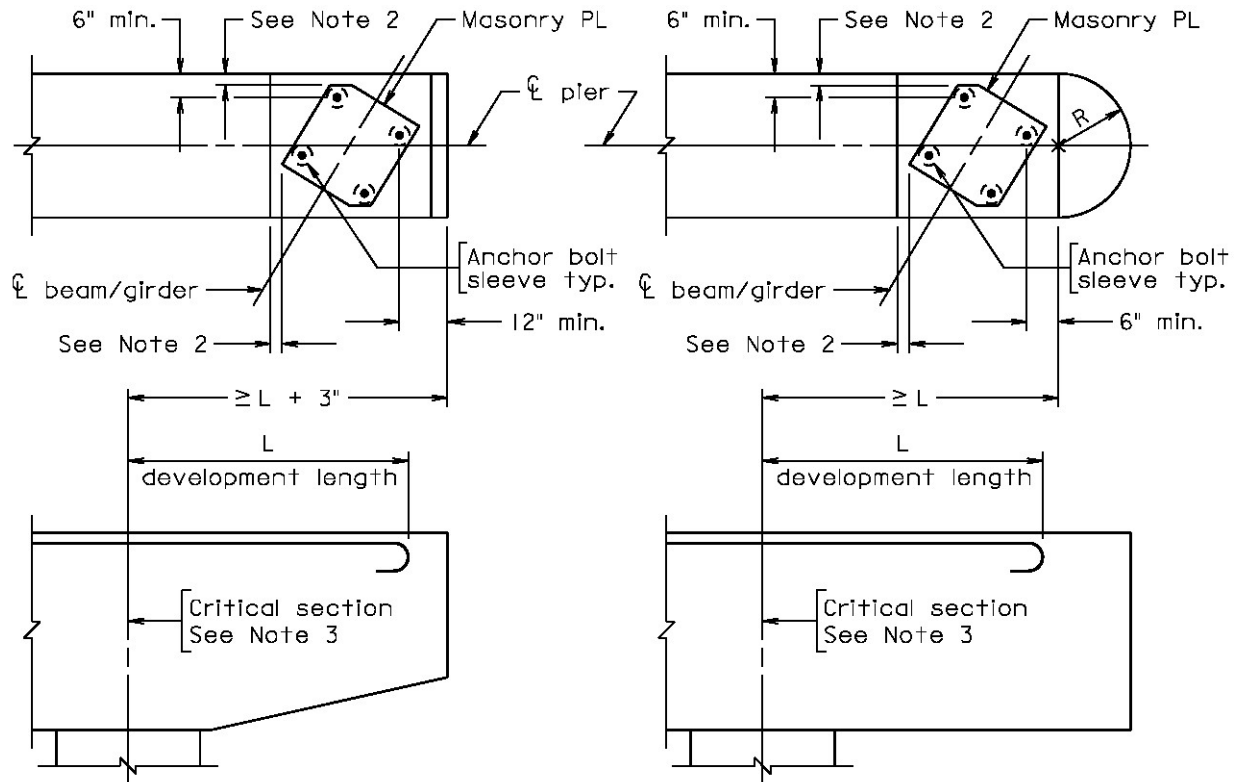

SQUARED CAP END

ROUNDED CAP END

Only when within hydraulic opening

Notes:

1. Set location of the center of the rounded cap end as follows:
 - at least 6" beyond center of the extreme anchor bolt.
 - at least a length equal to the development length (L) for the main bars beyond the critical section.

Use whichever gives the greater cap length.

2. The width of the pier seat shall be such that the edge of seat shall be at least 3" beyond the extreme point of the masonry plate and anchor bolt sleeve, where applicable, and 6" beyond the anchor bolt(s). Where masonry plate criteria controls cap width or length, the masonry plate may be clipped to provide the necessary clearance.
3. The critical section for multi-column cap bending moment (cantilever) with concentrated load(s) outside the centerline of the extreme column is the centerline of that column. For critical section for shear in cap, see AASHTO LRFD specifications, Articles 5.8.1 and 5.6.3.
4. For basic development length and modification factors, see Chapter 7, Section 2.
5. Top reinforcement shall be of sufficient length for supporting the stirrups.

REINFORCING DETAILS AT CORNER OF BEAM AND COLUMN (Cont'd):

For a closing corner, where the moments cause tension in the outside corner, the reinforcement near the outside surfaces shall be continuous.

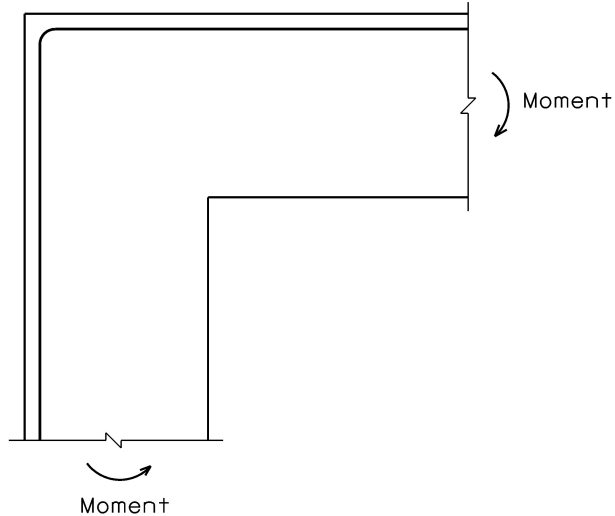

Reinforcement for Closing Corner

Considering constructability, the following detail can be used to detail the reinforcement in a closing corner. The lap splice lengths shall meet the AASHTO LRFD Specifications.

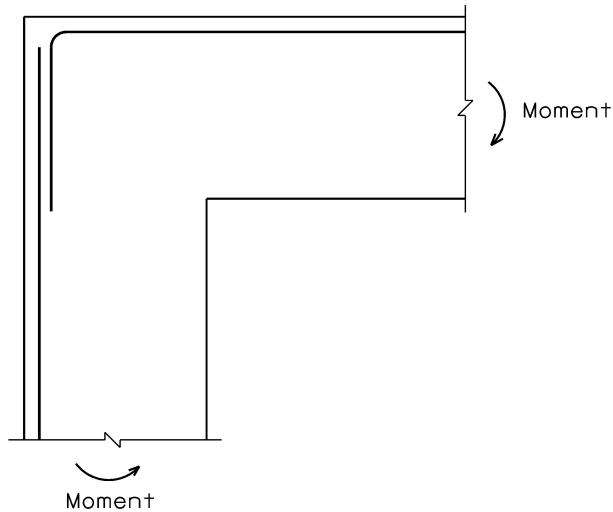

Alternative Reinforcement for Closing Corner

SAMPLE ANCHOR BOLT LAYOUTS:

TYPICAL ANCHOR BOLT LAYOUT shall include offset dimensions for each anchor bolt from one reference point and angles. Variable tables should accompany anchor bolt layouts where necessary. Cap width, centerline bearing to centerline pier, seat width and centerline of seat to edge of seat dimensions are normally shown in the cap PLAN view.

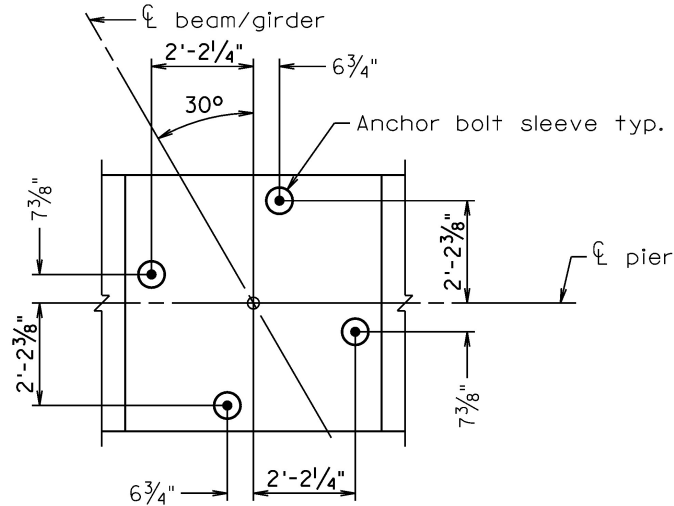

TYPICAL ANCHOR BOLT LAYOUT
(For skewed structures.
Bearing with 4 anchor bolts shown.)

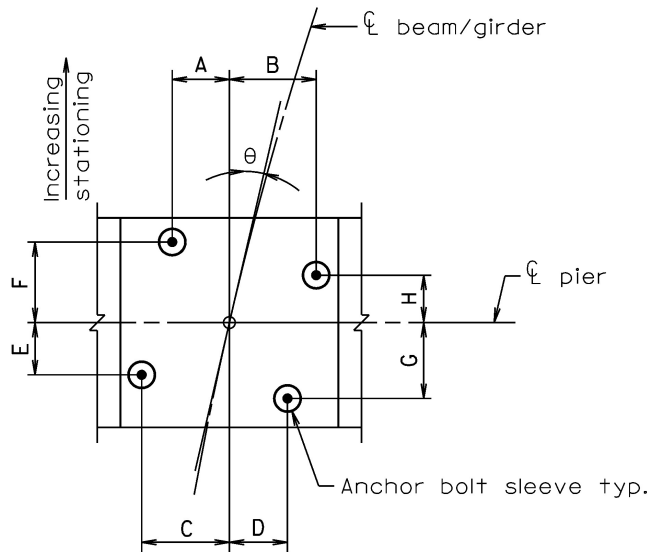

TYPICAL ANCHOR BOLT LAYOUT
(For curved structures.
Bearing with 4 anchor bolts shown.)

BOTTOM CAP SLOPE:

Bottom slopes for pier cap cantilevers should generally be limited to a range between 3 : 1 and 6 : 1 with the ratio of (cap depth) to (depth at end) generally limited to a range between 2 : 1 and 1.3 : 1. Deviations from these limits should be made only in cases of unusual pier geometry or to achieve architectural effects. Slopes shall not be used where the end of cap is less than 2'-6" deep and/or slope depth is less than 12". Slopes shall not be used on caps with rounded ends.

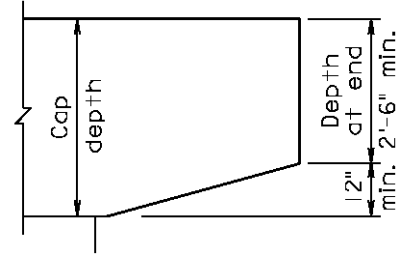

CAP REINFORCEMENT:

Top Bars:

All top main cap bars shall be hooked at the ends of the cap. Use 180 degree hooks with a single layer. Use 90 degree bends with two or more layers of top main bars. Laps should be avoided. If required, laps should be located near area(s) of maximum positive moment.

With two or more layers of top reinforcement, additional bar series are required (each successively shorter) to provide the required clear distance between bends. Cap dimensions shall be reevaluated if more than five layers are required.

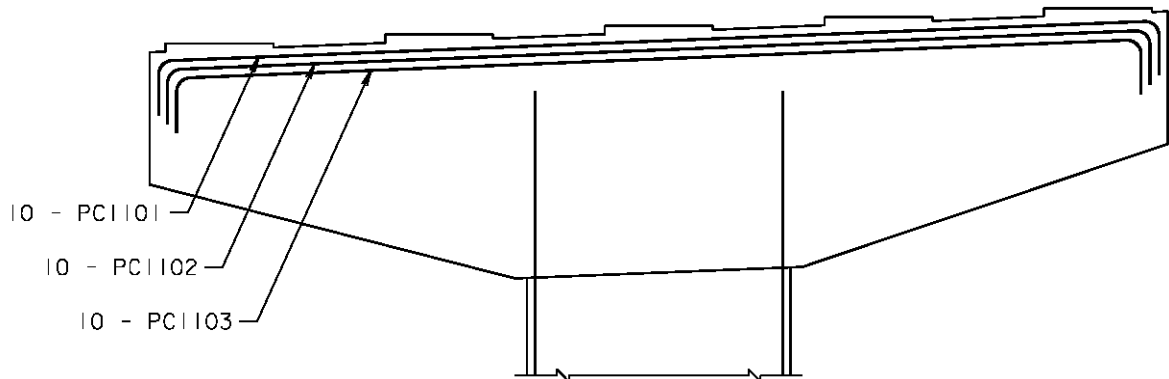

Bottom Bars:

Multi-column piers: Lowest bottom main cap bars in corners of stirrups shall be extended into cantilever. Others in lowest row and bars in other bottom rows may be terminated at interior end of cantilever (i.e. column side) except where additional bars require extension to meet shrinkage and temperature requirements. Laps should be avoided. If required, laps should be located near area(s) of maximum negative moment. See File No. 15.03-1 for example.

Hammerhead piers: Laps should be avoided. At a minimum, bottom main cap bars shall be placed in the corners of stirrups, consist of #6 bars or larger and meet shrinkage and temperature requirements.

CAP REINFORCEMENT (Continued):

Shrinkage and Temperature Bars:

For area and spacing requirements for shrinkage and temperature reinforcement, see AASHTO LRFD specifications, Article 5.10.8.

Stirrups:

Use #4 stirrups unless the spacing required is less than 4" (in which case #5 stirrups should be used). When two #5 stirrups do not satisfy the steel required, three stirrups in one plane may be used. When the stirrup area becomes excessive, the cap depth should be reevaluated.

Vertical legs of stirrups should be distributed across the cap width (Example 1). Two vertical legs may be placed between two adjacent main bars where the distance between main bars is greater than or equal to 5" (Example 2). Two vertical legs shall not be about the same main bar (Example 3).

Where designers are concerned with high torsion and splitting forces in pile bent caps (e.g. bents with staggered battered piles), stirrups may be arranged as shown in Example 4 where one stirrup encloses all the main bars and one or more stirrups provided on the interior.

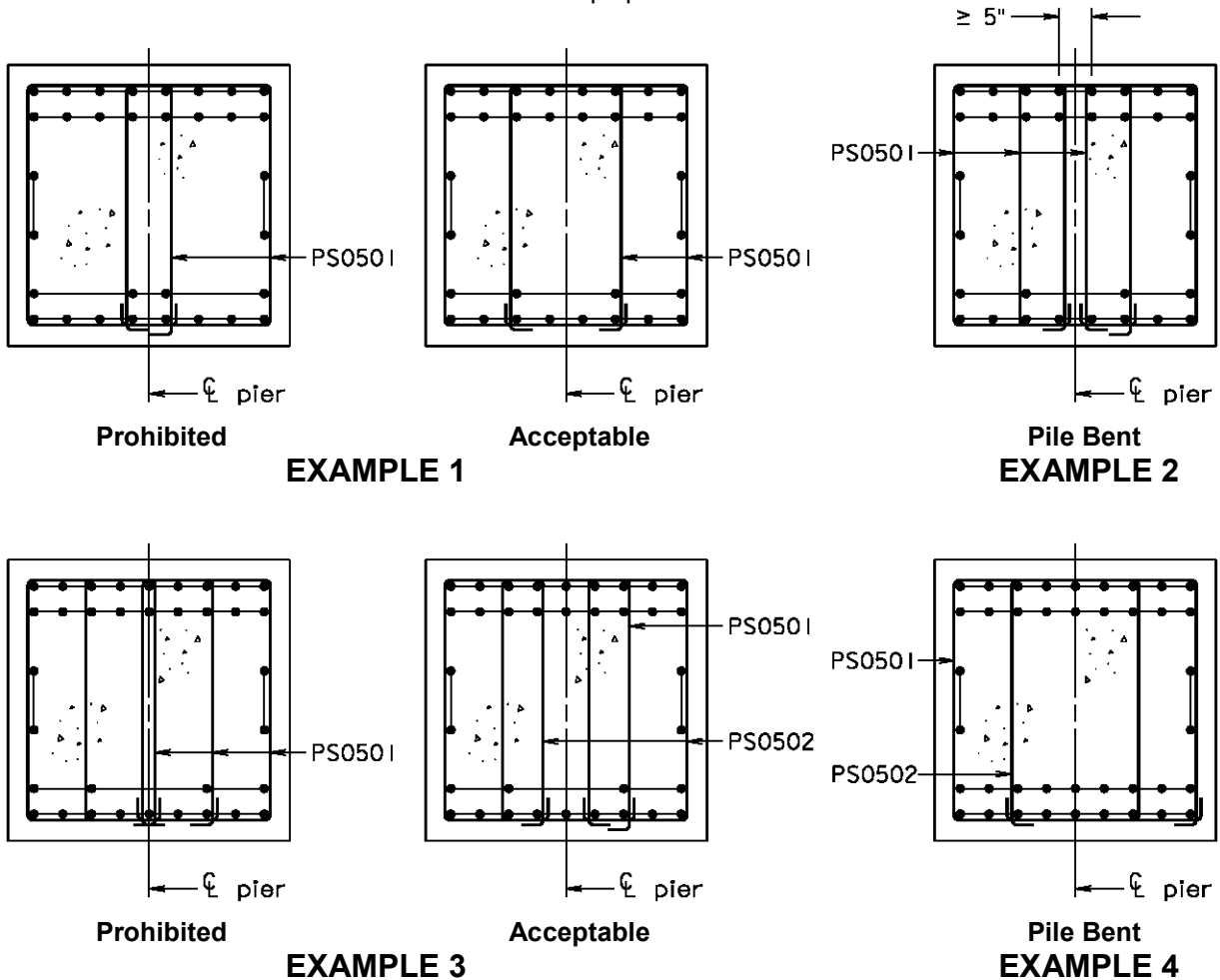

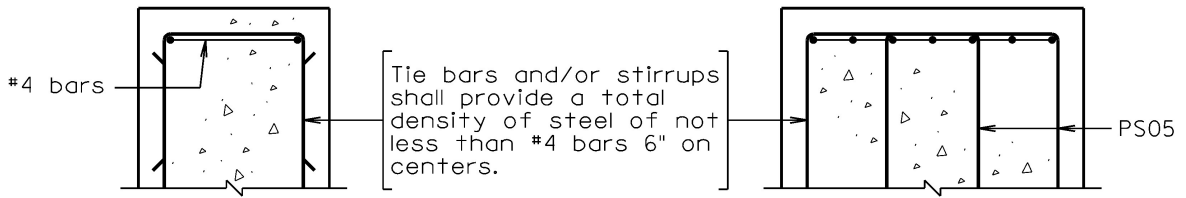

**PART SECTION THRU WALL /
SOLID PIER WITHOUT CAP**

**PART SECTION
THRU PIER CAP**

MAIN REINFORCEMENT < 6" TO TOP OF SEAT

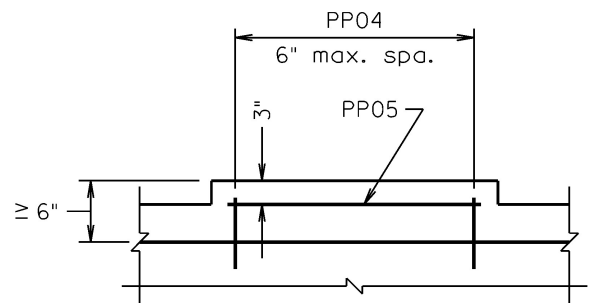
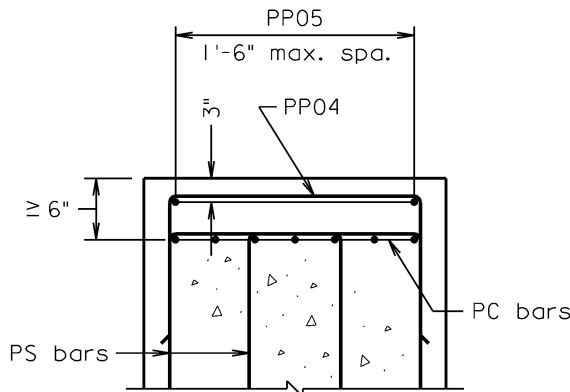

PART ELEVATION

PART SECTION

MAIN REINFORCEMENT ≥ 6" TO TOP OF SEAT

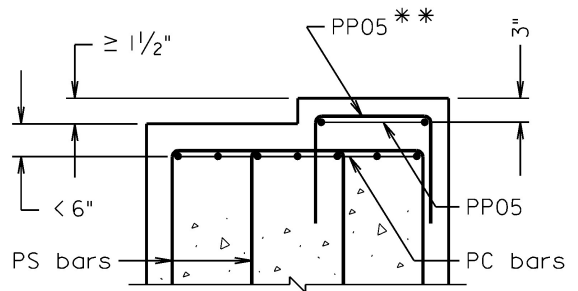
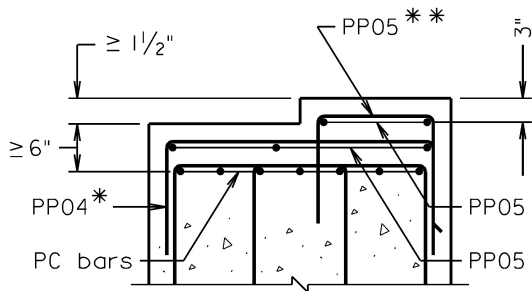

PART SECTION

PART SECTION

- * Minimum #4 bars @ 6" on centers as shown in PART ELEVATION for Main Reinforcement ≥ 6" to Top of Seat above.
- ** Minimum #5 bars @ 6" on centers where difference between top of seats is greater than or equal to 1/2" similar to PART ELEVATION shown above for Main Reinforcement ≥ 6" to Top of Seat.

SPLIT PADS

**PIER DETAILS
PIER COMPONENTS AND MISCELLANEOUS DETAILS
SEAT REINFORCEMENT**

PART 2
DATE: 30Apr2020
SHEET 8 of 15
FILE NO. 15.02-8

Columns:

Vertical reinforcement (PV series) in columns shall equal at least 1% of the gross concrete area of the column except for wall/solid piers. The minimum vertical reinforcement in wall/solid piers may be reduced to 0.5% of the gross concrete area as indicated on the following sheet. Maximum reinforcement shall be limited to 8% of the gross concrete area.

Vertical reinforcement extending into pier caps shall not be hooked. Pier caps shall be deep enough to allow adequate development length of the PV series without using hooks.

The minimum spacing between the vertical reinforcement from AASHTO LRFD specifications, Article 5.10.3.1, shall be provided between spliced bar sets with bars spliced side by side. Radial splicing to provide the required spacing for additional bars shall only be permitted where tied to inner hoops to maintain position.

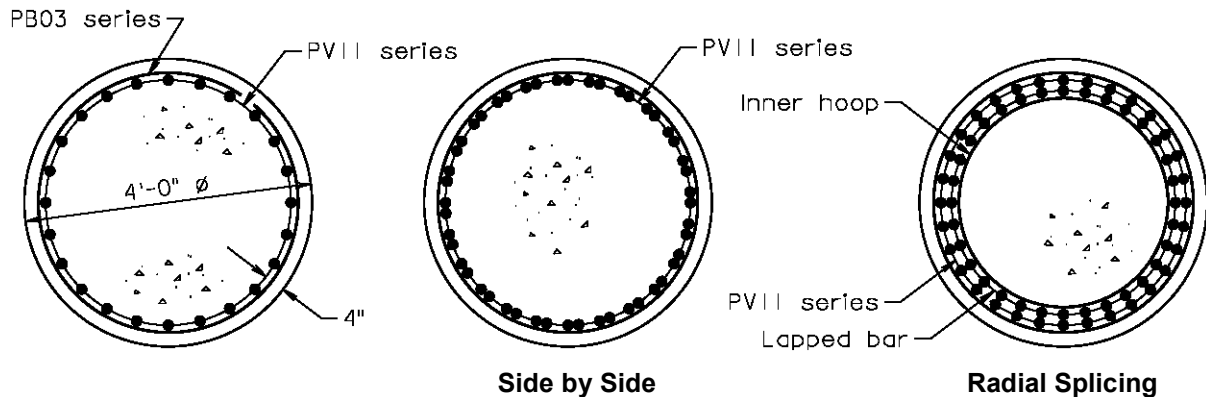

For spiral and tie requirements, see AASHTO LRFD specifications, Article 5.10.4. Circular columns shall be designed as tied columns. However, the confinement steel shall be continuous spirals (#3 reinforcing bars minimum) or welded wire fabric. The pitch of the spiral shall be taken as the required spacing for ties.

Multi-Column Piers:

The minimum column diameter shall be 3'-0". Where columns larger than 3'-0" are required, they shall be selected in 6" increments from 3'-0" to 5'-0". For diameters greater than 5'-0", 12" increments shall be used. The use of A4 ($f'_c = 4,000$ psi) concrete should be considered when its use will result in a reduction in column diameter.

The minimum bar size for vertical reinforcement is #9. Use ten (10) #9 bars for 3'-0" diameter column unless strength requirements indicate a larger area is needed.

Hammerhead Piers:

Main vertical reinforcement shall be detailed such that maximum concrete lifts will not exceed 30 feet.

The use of hollow column sections requires additional details for inspection including elevation markings on the interior, access ladders, lighting and power supply.

Columns (Cont'd):

Wall/Solid Piers:

The minimum wall thickness shall be 2'-6" unless a design approval request is submitted to and approved by the District Structure and Bridge Engineer.

AASHTO LRFD specifications Article 11.2 states solid wall piers are designed as columns for forces and moments acting about the weak axis and as piers for those acting about the strong axis. Article 5.7.4.2 states a reduced effective area may be used when the cross-section is larger than that required to resist the applied loading for bridges in Seismic Zone 1. Current ACI 318 10.3.1.2 limits the reduced effective area to one-half the gross area.

The minimum vertical reinforcement in wall/solid piers shall not be less than 0.5% of the gross concrete area. The area of vertical reinforcement provided shall not be less than required by Article 5.7.4.2 using a reduced effective area and as required to satisfy AASHTO LRFD limit state design. As such, the minimum area of vertical reinforcement extending from the footing into the wall for a wall thickness of 2'-6" is equivalent to #7 bars @ 8" each face where applicable.

Horizontal reinforcement in the wall shall not be less than #4 bars @ 12".

COLUMN TIES:

For spiral and tie requirements, see Article 5.7.4.6 of the AASHTO LRFD specifications. The column sections to the right depict additional tie arrangements adhering to the requirement of Article 5.10.6.3 that no vertical bar or bundle shall be more than 24" measured along the tie from a restrained bar or bundle.

In the first example (top), the dimensioned bars are less than 24" from a restrained bar and do not require an additional tie.

Comparing the second example (middle) to the first, the column dimensions were increased and the dimensioned bars now exceed 24" requiring an additional tie. Instead of adding two additional ties along the transverse face, one was added and the original tie position was moved so that all bars are less than 24" from a restrained bar.

Comparing the third example (bottom) to the second, the column dimensions remain the same, but the number of vertical bars is one less in each longitudinal face. The dimensioned bars are less than 24" from a restrained bar and do not required an additional tie.

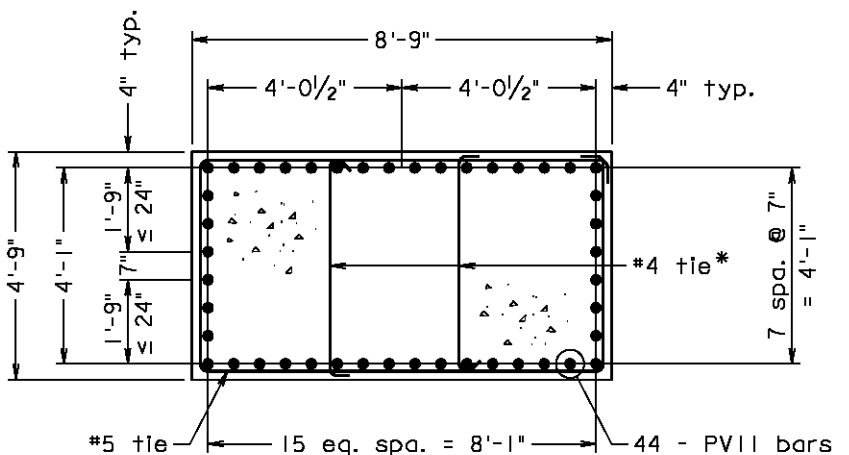
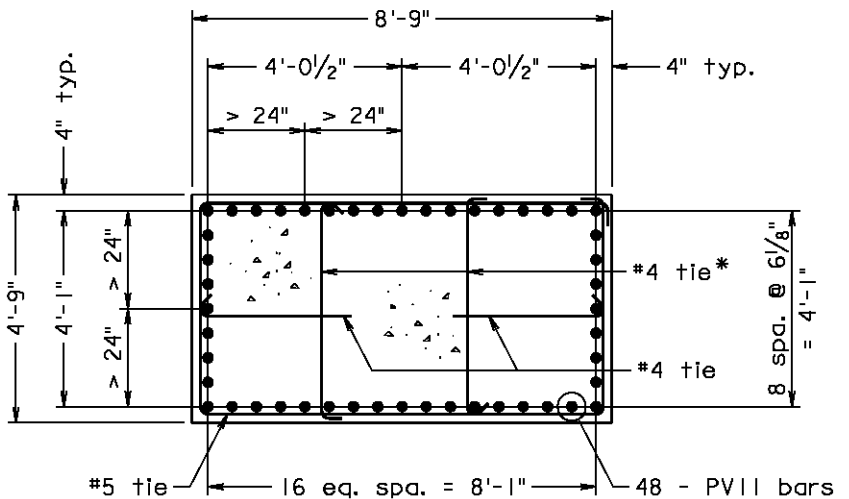
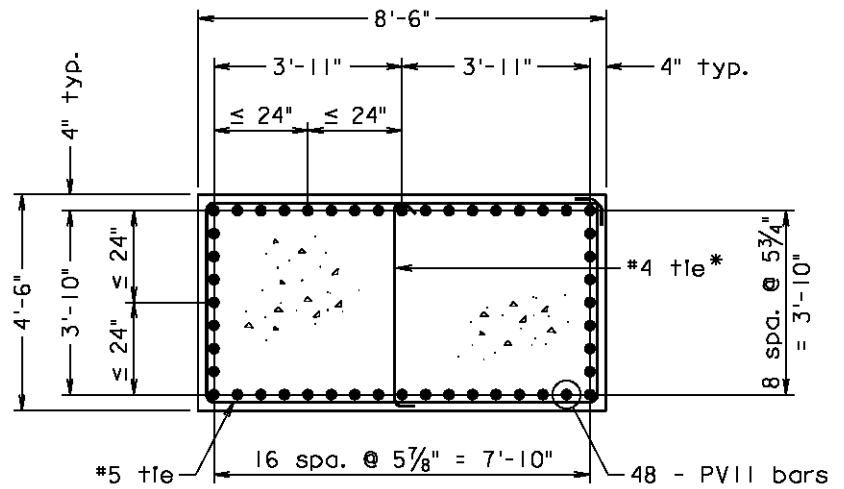
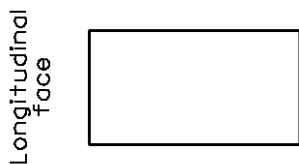

*Alternate position of hooks and bends at each level

FOOTING TYPES AND DETAILS:

Minimum footing depth shall be 3'-0" except for footings with square prestressed concrete piles where the minimum footing depth shall be increased as indicated in File No. 15.02-11.

Footing dimensions for each column (including pile layout where applicable) at a multi-column pier should be identical. With stepped footings, the shorter column length is stiffer and draws more load. The longer column carries less load, but is more slender. The required footing sizes should have similar dimensions and one footing size used.

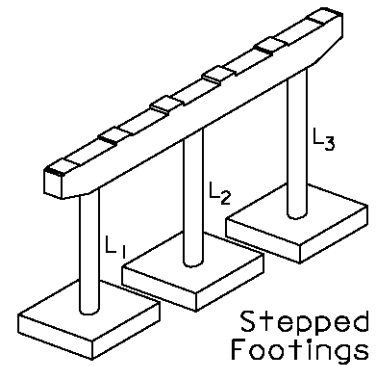

Footing dimensions should be kept the same between all similar types of piers except on larger projects where design loads, geometry or geotechnical requirements vary substantially across the spans or where specific need exists (e.g. minimum footing size is necessary to provide required clearance for sheet piling during construction). In these situations, footing sizes should be grouped.

Top of footings shall be a minimum of 12" below existing ground or finished grade. Top of footings for overpasses shall be a minimum of 12" below the invert of adjacent ditch or top of fill slope. When a pier protection barrier (BPPS) is required, the 12" minimum shall be increased to 2'-6" to avoid interference with the BPPS footing. For stream crossings, footing shall be located at a depth to provide for safety against scour.

Shrinkage and temperature reinforcement, as defined in AASHTO LRFD 5.10.6, is not required for side faces of buried footings less than 5'-0" in depth. For buried footings 5'-0" or deeper, provide #5 bars at 12" spacing on each face and in each direction.

Spread footing:

A spread FOOTING PLAN is shown on File No. 15.03-2 for a hammerhead pier. A TYPICAL FOOTING PLAN for a multi-column pier is similar.

To allow for field adjustment due to actual subsurface conditions, piers utilizing spread footings shall be designed for an additional two feet of column length (i.e. two foot drop in bottom of footing elevation). Reinforcing steel shall be detailed accordingly such that, at the lower footing elevation, the minimum lap for the column main vertical steel is maintained and the spiral pitch or tie spacing can be adjusted and satisfy design requirements.

Pile footing:

For a hammerhead pier or multi-column pier where piles are used in the footing, rest the bottom reinforcement mat on top of the piles. This allows the entire mat of reinforcing steel to be tied off and lowered onto the pile group. See File No. 15.03-1 for an example of a TYPICAL FOOTING PLAN for a multi-column pier using steel piles. A FOOTING PLAN for a hammerhead pier is similar.

For wall piers with piles, the footing reinforcement is likely to be tied in place as lowering a long narrow flexible mat on top of the piles may not be feasible. Reinforcement should be detailed at the bottom of the footing allowing the designer to take advantage of the full footing depth for moment and shear calculations. Due to the low number and size of bars typically required, conflicts with pile spacing could exist, but slight field adjustments can be made. Additional bars shall be detailed over the piles transversely and longitudinally.

DRILLED SHAFTS (Continued):

Drilled Shafts Supporting Footing:

When drilled shafts support a footing, the drilled shaft bars must be fully developed into the footing. Typically, large bar sizes and minimum footing depth require the main drilled shaft reinforcement to be hooked. If turned outward, these hooked bars will interfere with removing the temporary steel casing used to form drilled shafts. If turned inward, these hooked bars may interfere with the tremie tube and/or collar(s) during concrete placement when the clear opening in the drilled shaft reinforcement cage is less than 1'-3".

Where clear distance between hooks is greater than or equal to 1'-3", hooks shall be oriented toward the interior and main vertical reinforcement spliced away from the top of drilled shaft (Case 1). Where clear distance between hooks is less than 1'-3", splice main vertical reinforcement at the top of drilled shaft and rotate the main vertical reinforcement hooks to provide 1'-3" clear where feasible (Case 2).

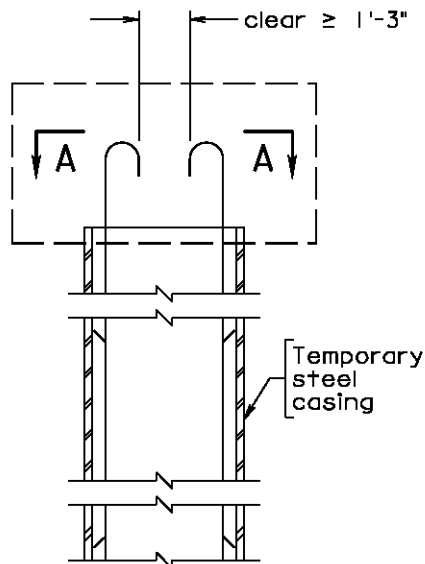

CASE 1

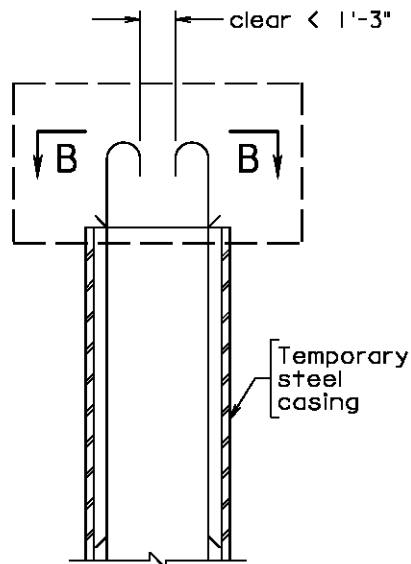

CASE 2

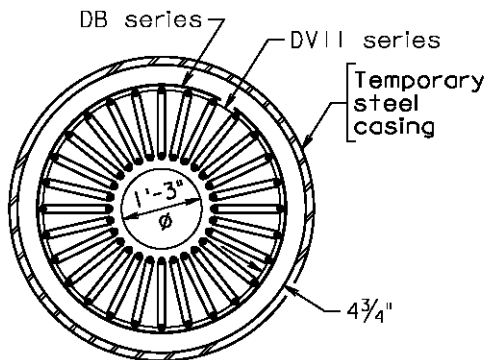

VIEW A-A (CASE 1)

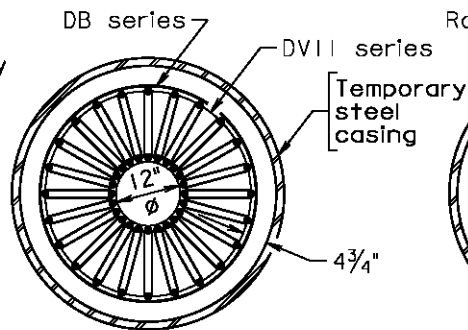

Radial

VIEW B-B (CASE 2)

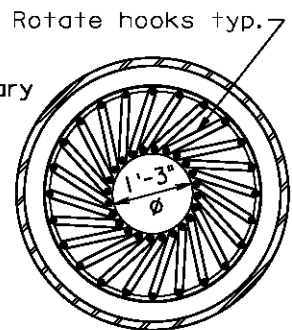

Rotated

DRILLED SHAFTS (Continued):

Drilled Shafts Supporting Footing (continued):

Where there is insufficient room to rotate the hooks to provide the minimum 1'-3" clear opening (bar overlap), the configuration is considered too tight for field implementation or it is desirable to open up spacing, some hooks may be rotated so the ends fall outside the reinforcement cage, but within the limits of the temporary steel casing. Rotate the remaining hooks on the interior to provide the minimum 1'-3" clear opening and relatively even spacing between hook ends.

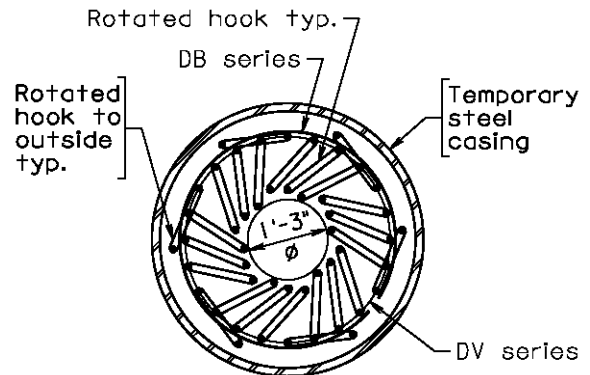

VIEW B-B (CASE 2 ALTERNATE)

Where the minimum 1'-3" clear opening cannot be obtained by methods discussed in Case 2, options include increasing drilled shaft diameter and increasing footing depth. With sufficient footing depth, main vertical drilled shaft bars can be developed without hooks (Seismic Zone 1 only). With sufficient footing depth, hooks can also be staggered beyond the minimum development length, but must clear the top reinforcement mat (see PART ELEVATION). Where staggered hooks are used, alternate the position of adjacent bars.

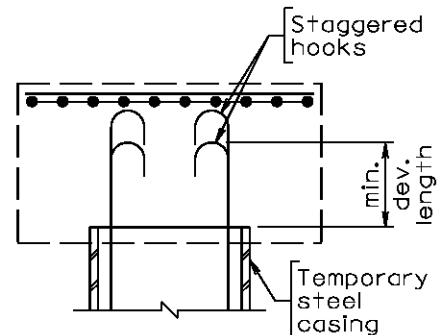

PART ELEVATION

Where permanent casing will be used, hooks shall be turned outward.

Details similar to those shown in this section (ELEVATION and VIEW) shall be provided on the plan sheets to show the intended layout of the hooks.

Drilled Shafts – Spacing, Tolerance, Embedment, Edge Distance:

Drilled shaft spacing and tolerance shall be in accordance with VDOT *Special Provision for Drilled Shafts* and AASHTO LRFD Specifications with VDOT Modifications, current IIM-S&B-80.

Projection (embedment) in caps/footings: 6" into footing with reinforcement projecting to obtain development as required by the design

Edge distance: The distance from the side of any shaft to the nearest edge of the footing/cap shall not be less than 12".

Notes:

When finishing concrete between and beyond pads, float surface to drain from center of pier to edges of cap.

Welded wire fabric may be substituted for spiral reinforcement in pier columns, maintaining an equivalent area of reinforcement, subject to approval by the Bridge Engineer.

For anchor bolt sleeve details, see bearing details on sheet 11.

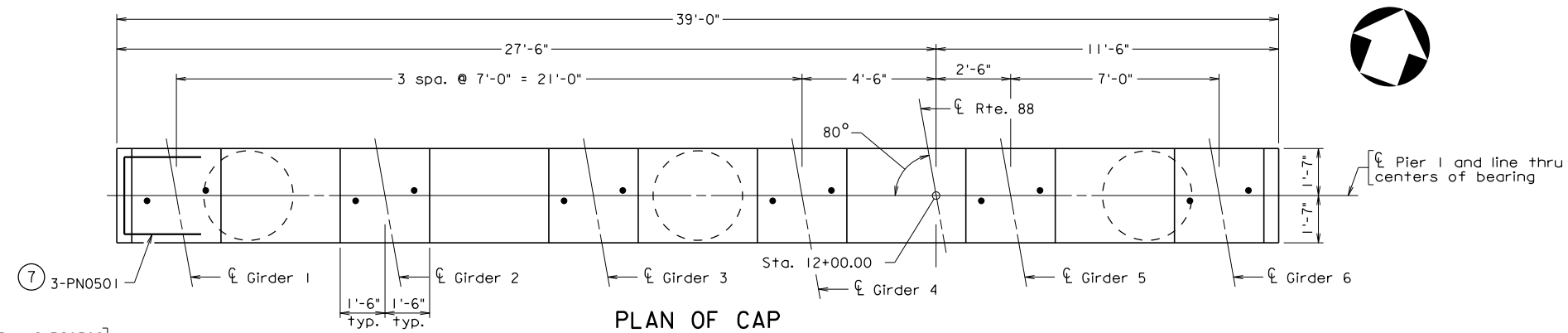

PLAN OF CAP

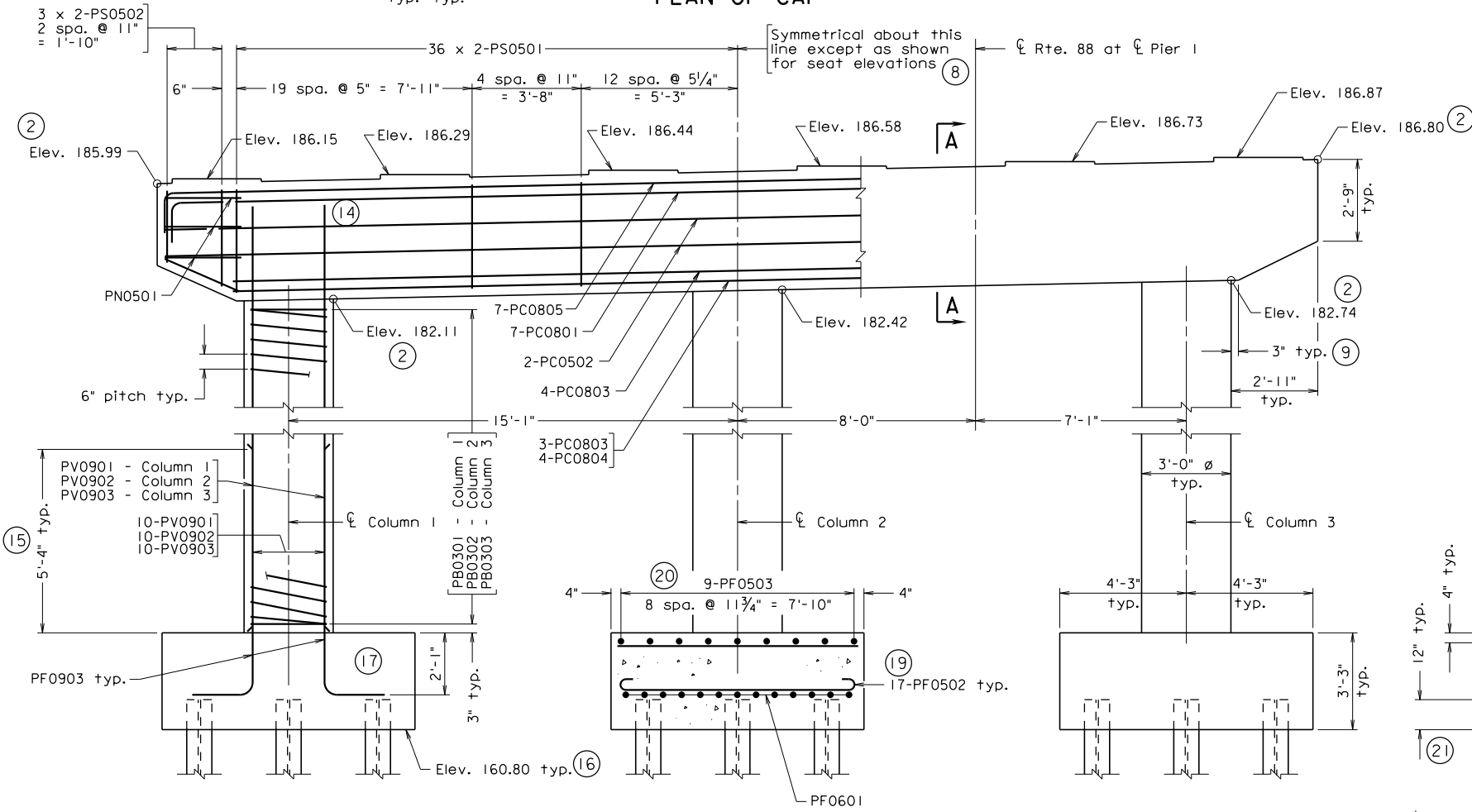

ELEVATION

- PV0901 - Column 1
- PV0902 - Column 2
- PV0903 - Column 3
- 10-PV0901
- 10-PV0902
- 10-PV0903
- PB0301 - Column 1
- PB0302 - Column 2
- PB0303 - Column 3

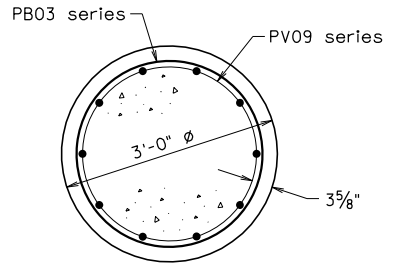

TYPICAL SECTION OF COLUMN
Scale: 3/4" = 1'-0"

PILE DATA TABLE				
Substructure Unit	Nominal Axial Resistance Measured During Driving (Tons/pile)	Factored Axial Resistance (Tons/pile)	Estimated Tip Elevation	Minimum Tip Elevation
Pier I	170	110	122	127

The Strength Limit State controls the pile design.

SAMPLE MULTI-COLUMN PIER SHEET
PIER DETAILS

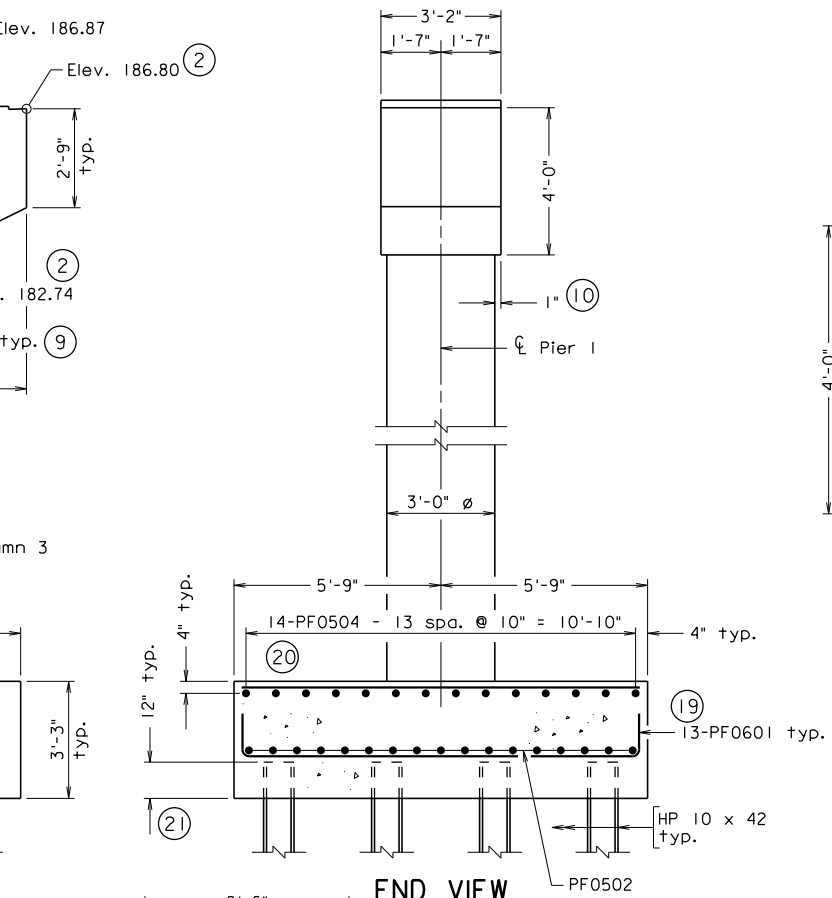

END VIEW

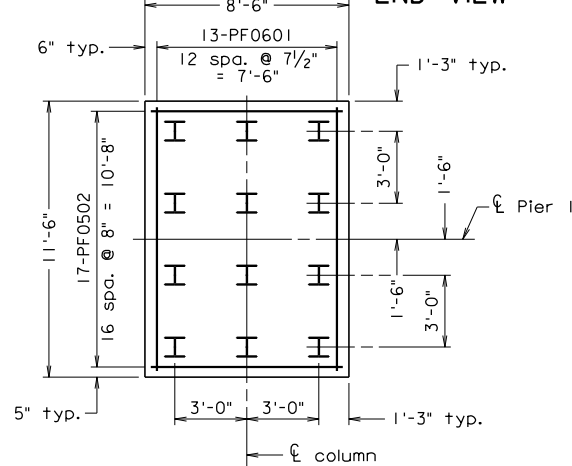

TYPICAL FOOTING PLAN

PF0503 and PF0504 steel reinforcement omitted for clarity

Scale: 1/4" = 1'-0"

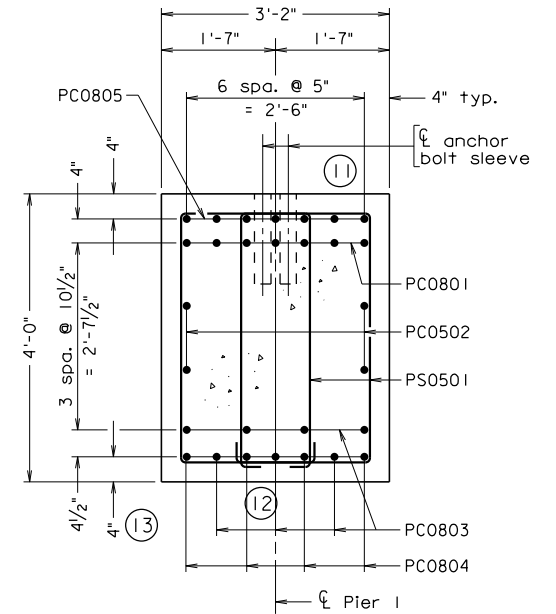

SECTION A-A

Scale: 3/4" = 1'-0"

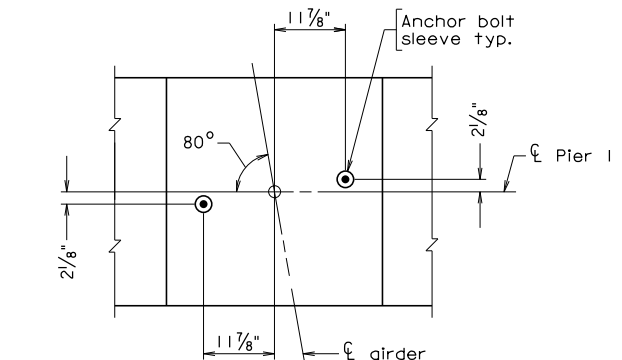

TYPICAL ANCHOR BOLT LAYOUT

Scale: 3/4" = 1'-0"

Scale: 3/8" = 1'-0" unless otherwise noted

© 2020, Commonwealth of Virginia

COMMONWEALTH OF VIRGINIA DEPARTMENT OF TRANSPORTATION			
STRUCTURE AND BRIDGE DIVISION			
PIER I			
No.	Description	Date	Plan
			999
Revisions		Designed: SUB	Date: Apr. 2020
		Drawn: SUB	
		Checked: SUB	
			PART 2 DATE: 30Apr2020 SHEET 1 of 12 FILE NO. 15.03-1

999-99-010.dgn

STATE	FEDERAL AID	STATE	SHEET NO.
ROUTE	PROJECT	ROUTE	PROJECT
VA.		58	0058-041-116, B607

Notes:

When finishing concrete between and beyond pads, float surface to drain from center pier to edges of cap.

For closure diaphragm details, see sheet 12.

Dowels can be adjusted to miss PS05 series bars.

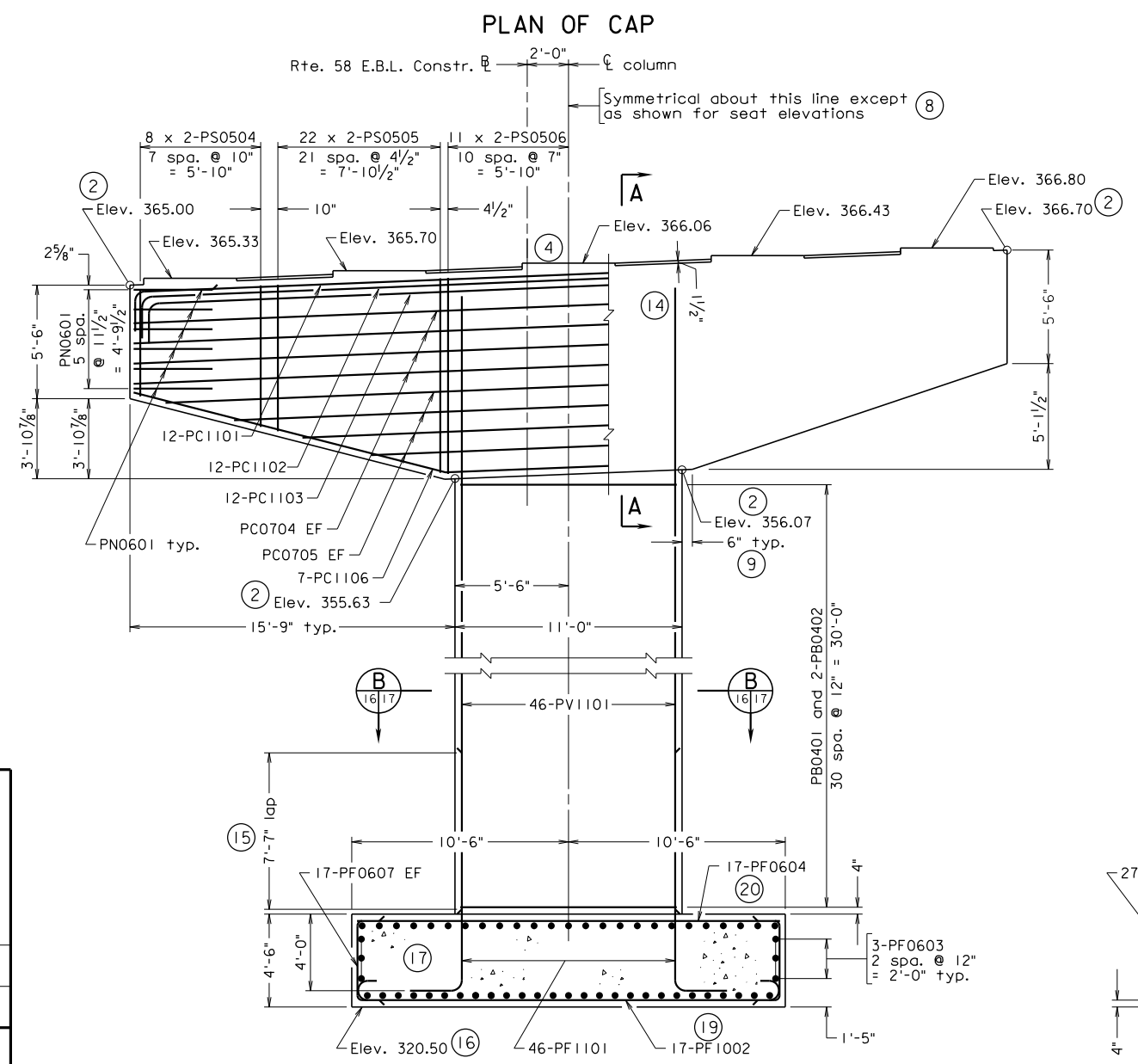
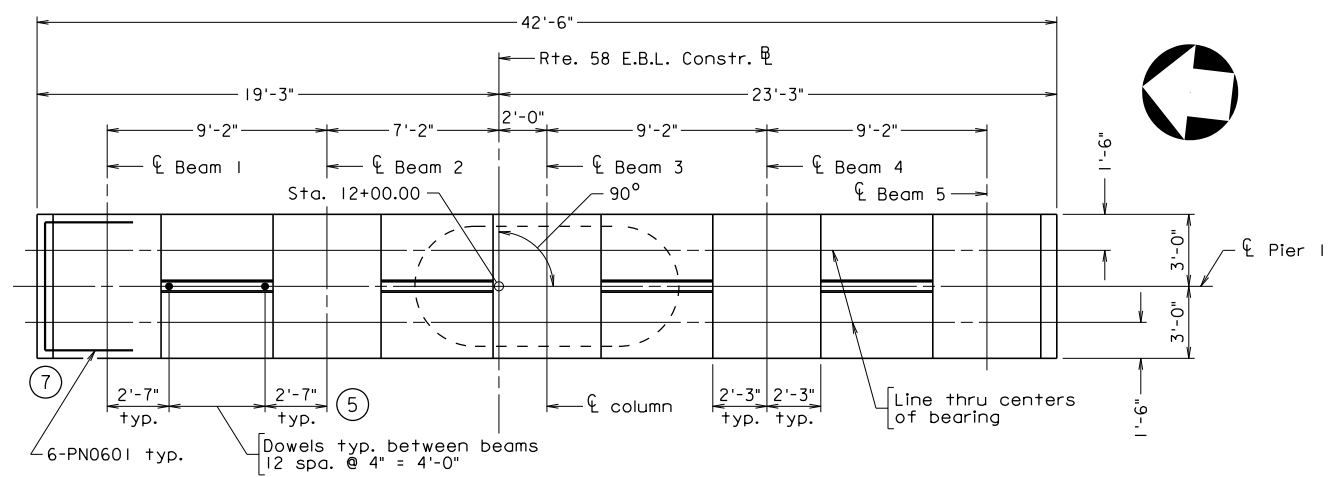

**SAMPLE HAMMERHEAD PIER SHEET
PIER DETAILS**

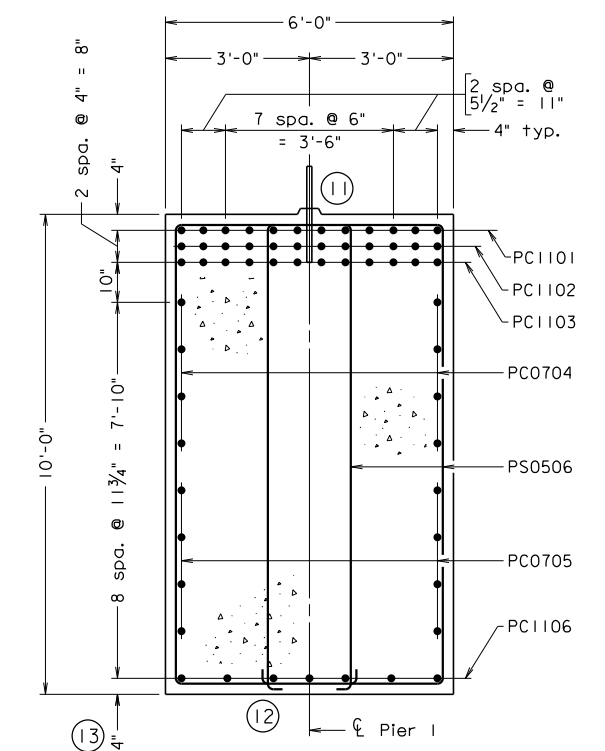
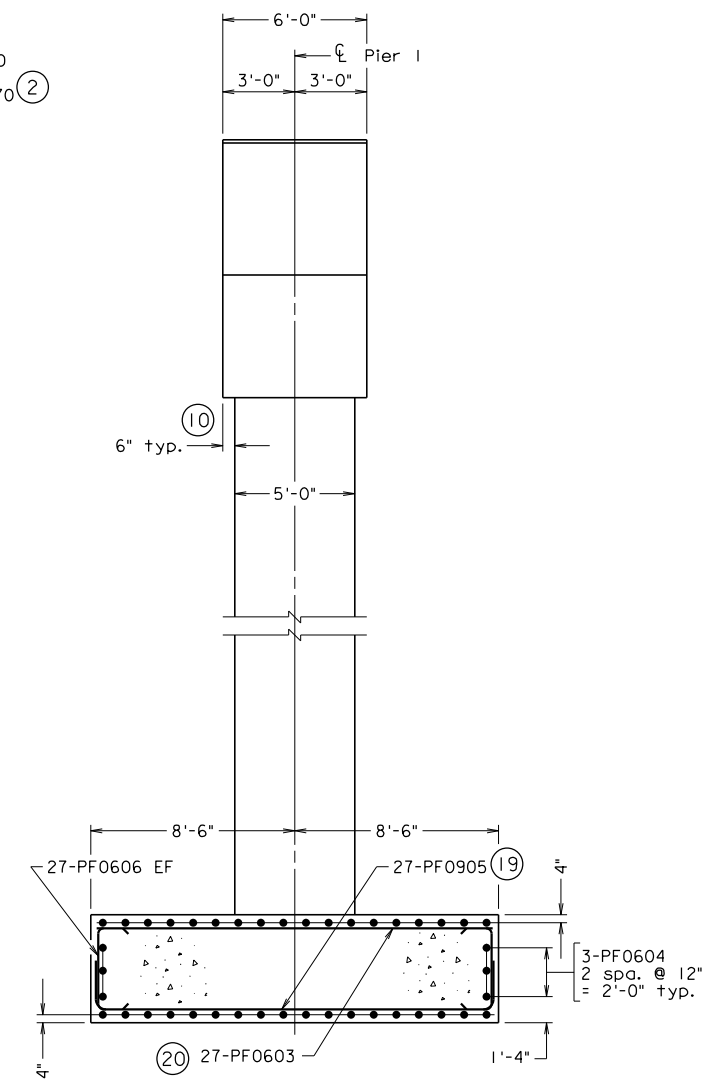

SECTION A-A
Scale: 1/2" = 1'-0"

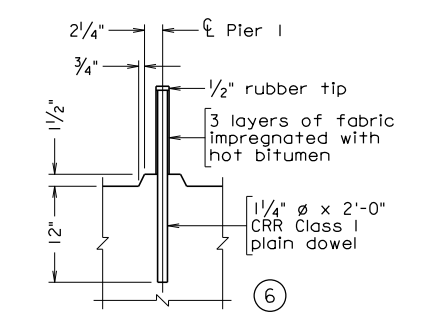

DOWEL DETAIL
Not to scale

Scale: 1/4" = 1'-0" unless otherwise noted

© 2020, Commonwealth of Virginia

999-99.016.dgn

VDOT S&B DIVISION
RICHMOND, VA
STRUCTURAL ENGINEER

COMMONWEALTH OF VIRGINIA DEPARTMENT OF TRANSPORTATION	
STRUCTURE AND BRIDGE DIVISION	
PIER I PLAN AND ELEVATIONS	
No.	Description
Date	Date
Designed: SUB	Date
Drawn: SUB	Plan
Checked: SUB	Apr. 2020
999	
PART 2 DATE: 30Apr2020 SHEET 2 of 12 FILE NO. 15.03-2	

Notes:
For cap reinforcement details, see sheet 16.

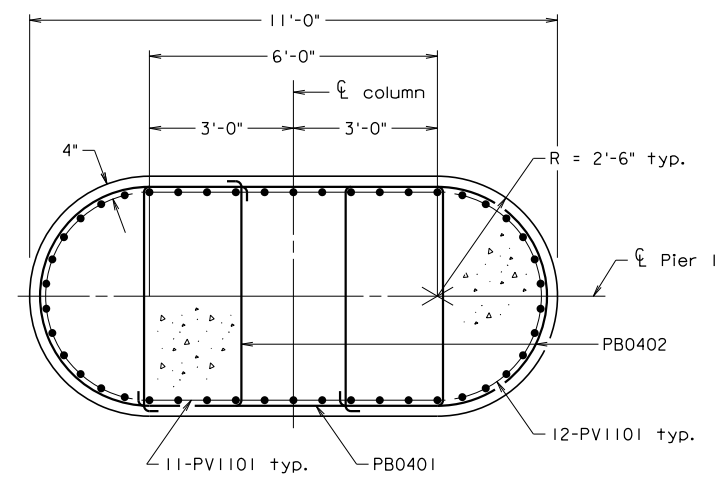

SECTION B
Scale: 1/2" = 1'-0"

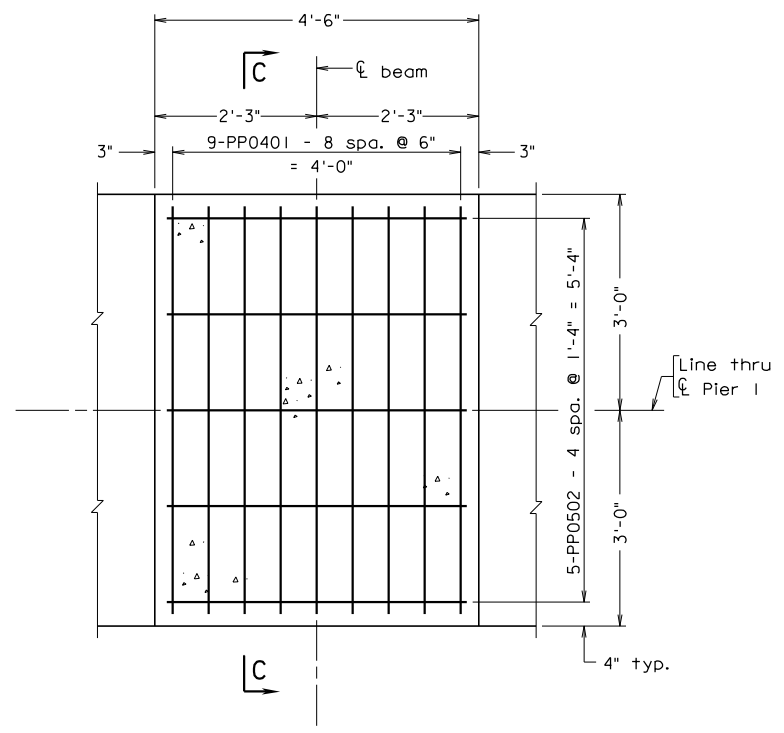

TYPICAL SEAT/PAD REINFORCEMENT
Scale: 3/4" = 1'-0"

(22)

Substructure Unit	Anticipated Bearing Material	SERVICE LIMIT STATE		STRENGTH LIMIT STATE	
		Tolerable Settlement (inches)	Maximum Applied Bearing Pressure* (tsf)	Maximum Factored Bearing Pressure* (tsf)	Required Nominal Bearing Resistance (tsf)
Pier 1	Rock	0.5	5.0	8.0	17.8

*The larger of these two values, as well as the Anticipated Bearing Material, shall be verified by the inspector or Engineer-of-Record prior to placing the footing concrete.

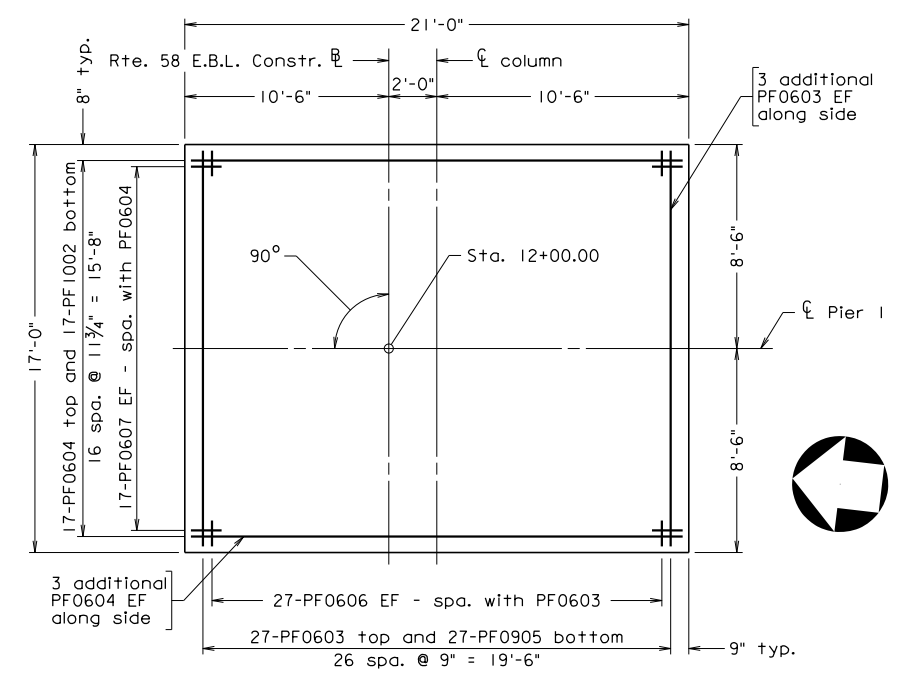

FOOTING PLAN

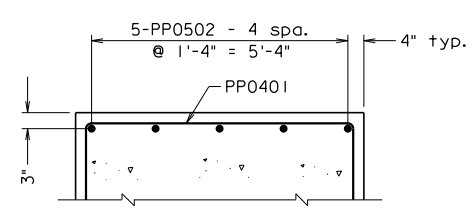

SECTION C-C
Pier cap main reinforcement omitted for clarity
Scale: 1/2" = 1'-0"

**SAMPLE HAMMERHEAD PIER SHEET
PIER DETAILS**

Scale: 1/4" = 1'-0" unless otherwise noted

			COMMONWEALTH OF VIRGINIA DEPARTMENT OF TRANSPORTATION	
			STRUCTURE AND BRIDGE DIVISION	
			PIER 1 FOOTING PLAN, SECTIONS AND DETAILS	
No.	Description	Date	Designed: SUB	Date
			Drawn: SUB	Apr. 2020
			Checked: SUB	999
Revisions			Plan	PART 2 DATE: 30Apr2020 SHEET 3 of 12 FILE NO. 15.03-3

999-99.017.dgn

(29)

Notes:
 When finishing concrete between and beyond pads, float surface to drain from center pier to edges of cap.
 For closure diaphragm details, see sheet 12.
 Dowels can be adjusted to miss PS0401 bars.

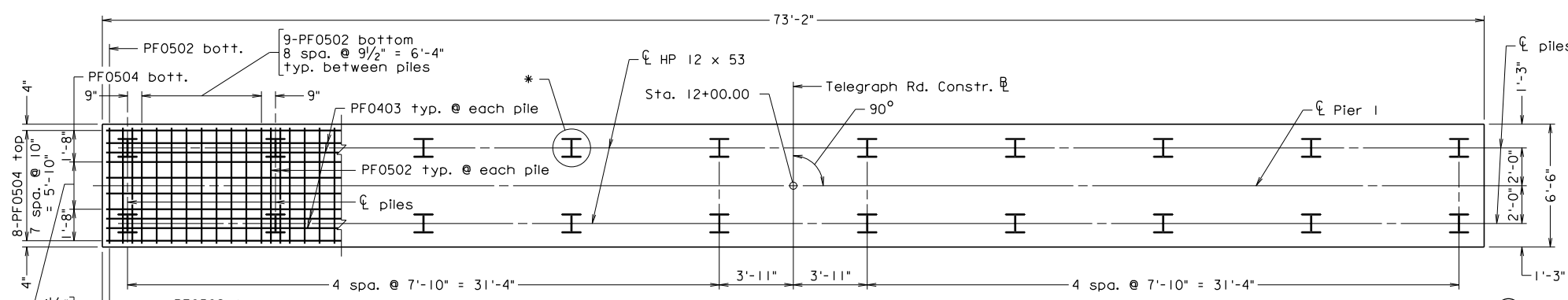
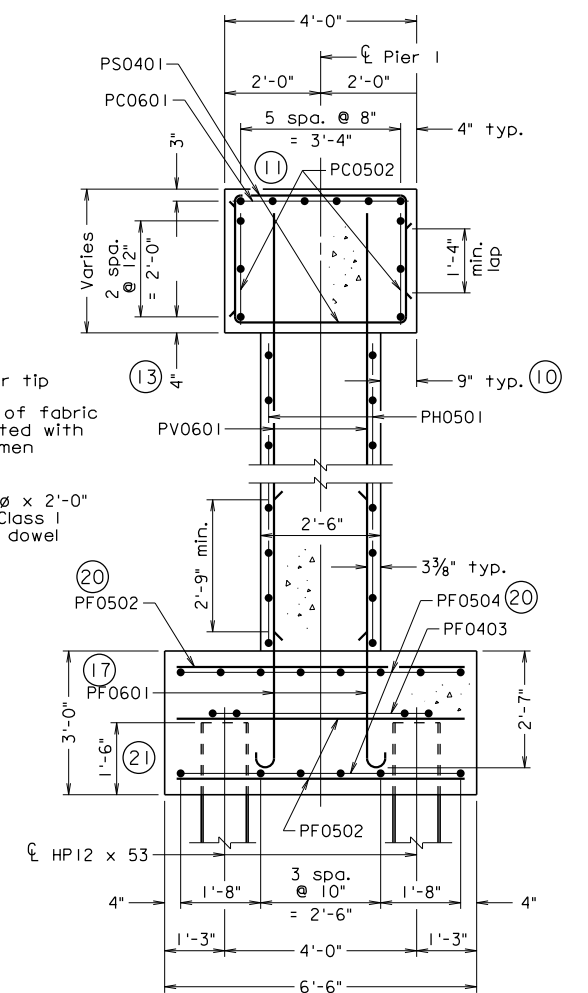
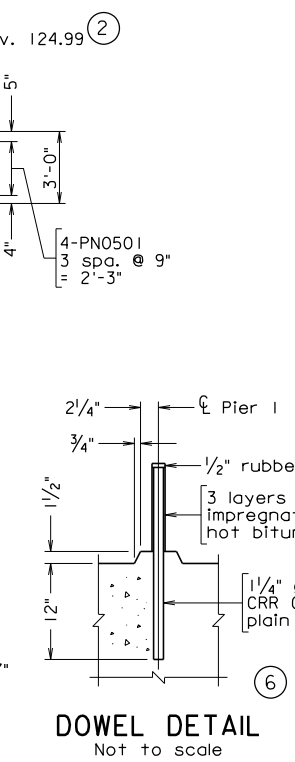
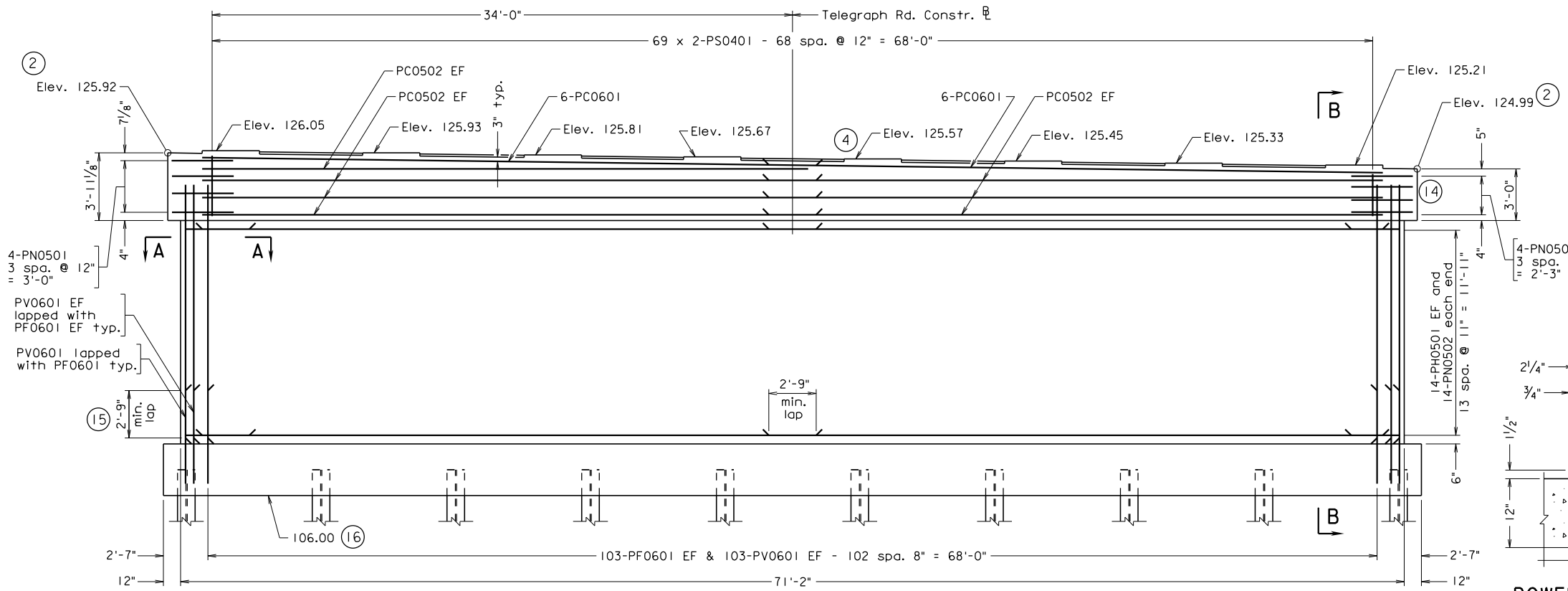
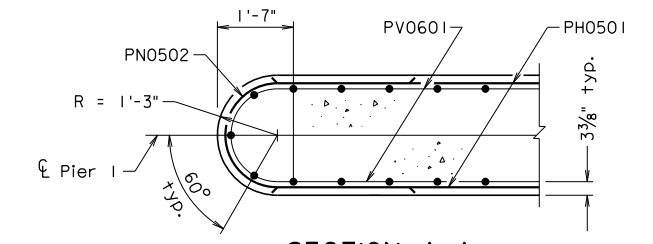
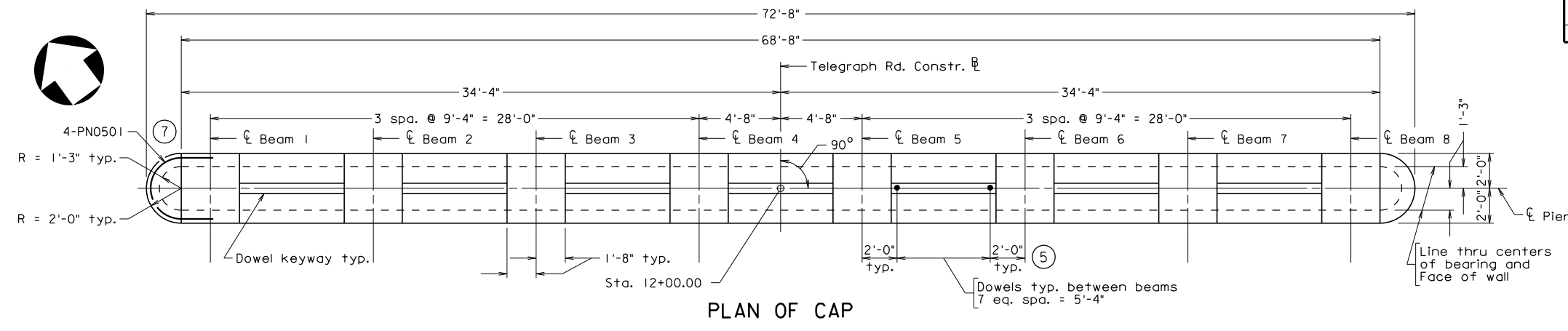

**SAMPLE WALL PIER SHEET
PIER DETAILS**

Substructure Unit	Nominal Axial Resistance Measured During Driving (Tons/pile)	Factored Axial Resistance (Tons/pile)	Estimated Tip Elevation	Minimum Tip Elevation
Pier I	210	136	91	95

The Strength Limit State controls the pile design.

Scale: 1/4" = 1'-0" unless otherwise noted

COMMONWEALTH OF VIRGINIA DEPARTMENT OF TRANSPORTATION STRUCTURE AND BRIDGE DIVISION			
PIER I			
No.	Description	Date	Plan
		Apr. 2020	999
Revisions		Designed: SUB	Checked: SUB
		Date	Plan
		Apr. 2020	999

PART 2
DATE: 30Apr2020
SHEET 4 of 12
FILE NO. 15.03-4

999-99.016.dgn

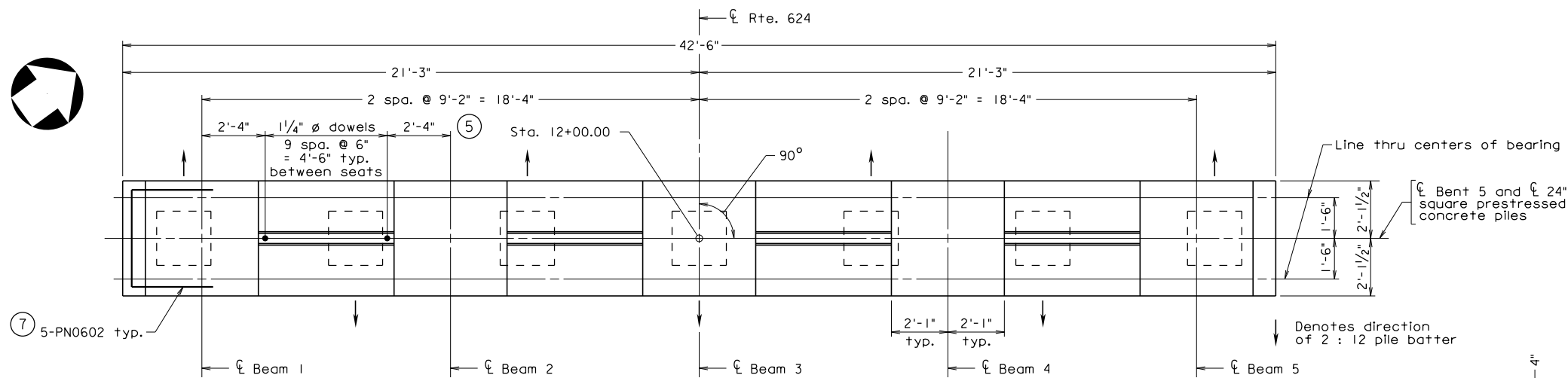

PLAN OF CAP

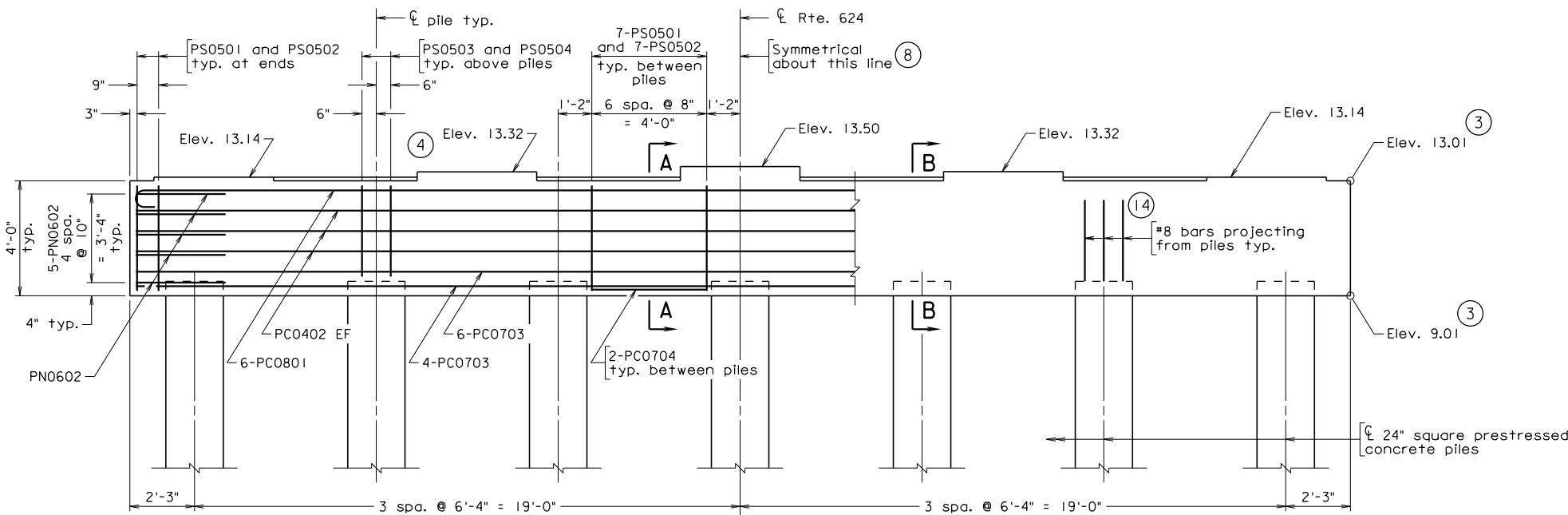

ELEVATION

Substructure Unit	Nominal Axial Resistance Measured During Driving (Tons/pile)	Factored Axial Resistance (Tons/pile)	Estimated Tip Elevation	Minimum Tip Elevation
Bent 1	250	163	-50	-45
Bent 2	250	163	-49	-46
Bent 3	250	163	-49	-46
Bent 4	250	163	-49	-46
Bent 5	290	163	-78	-73
Bent 6	290	163	-73	-68
Bent 7	250	163	-50	-45

The Strength Limit State controls the pile design.

**SAMPLE PILE BENT SHEET
PIER DETAILS**

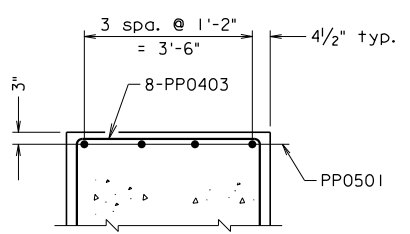

SECTION C-C

Bent cap main reinforcement omitted for clarity
Scale: 1/2" = 1'-0"

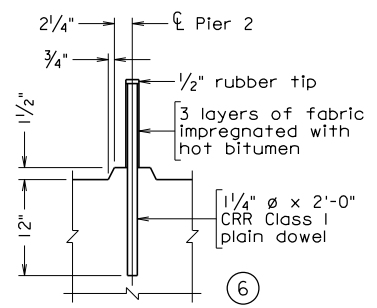

DOWEL DETAIL

Not to scale

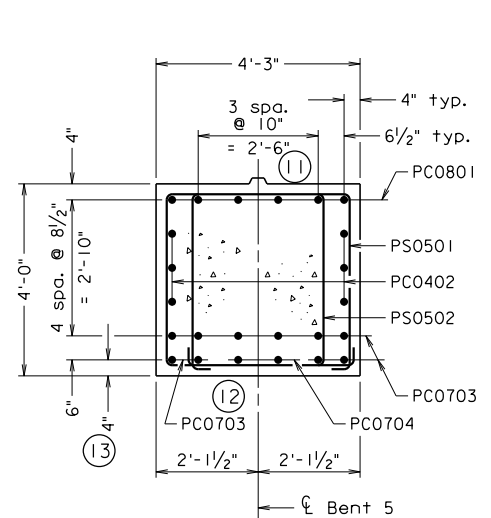

SECTION A-A

Scale: 1/2" = 1'-0"

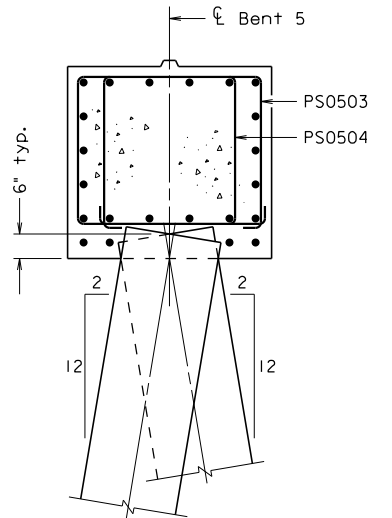

SECTION B-B

For details not shown, see Section A-A
Scale: 1/2" = 1'-0"

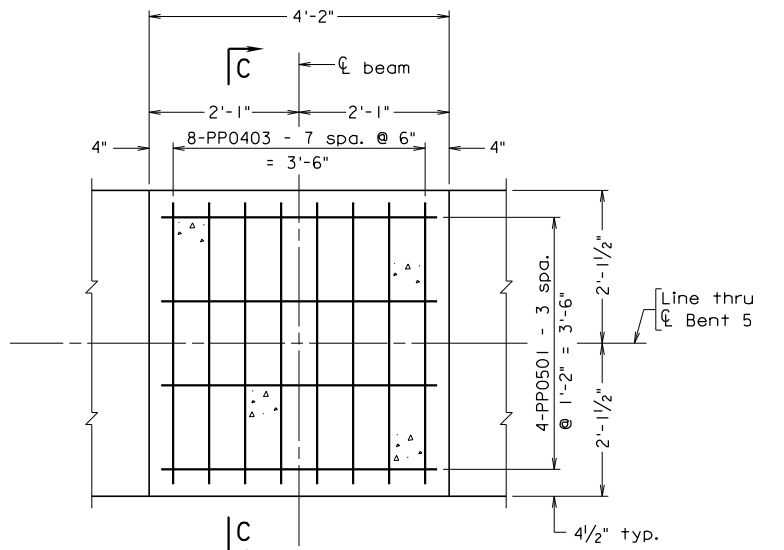

TYPICAL SEAT REINFORCEMENT
(GIRDERS 2 THRU 4)

Scale: 3/4" = 1'-0"

COMMONWEALTH OF VIRGINIA DEPARTMENT OF TRANSPORTATION		STRUCTURE AND BRIDGE DIVISION	
BENT 5			
No.	Description	Date	Plan
		Apr. 2020	999
Revisions		Designed: SUB	Checked: SUB
		Date	Plan
		Apr. 2020	999
		Drawn: SUB	FILE NO. 15.03-5
		Checked: SUB	

Scale: 3/8" = 1'-0" unless otherwise noted

999-99.012.dgn

DETAILING CHECK LIST FOR PIERS / BENTS

- 1 Show Plan of Cap, Elevation, End View and (Typical) Footing Plan at a scale of $\frac{3}{8}'' = 1'-0''$, but no smaller than $\frac{1}{4}'' = 1'-0''$. Show remaining details at a scale of $\frac{3}{4}'' = 1'-0''$, but no smaller than $\frac{1}{2}'' = 1'-0''$.
- 2 Slope cap from end-to-end when seat heights of 4" or more can be avoided. Slope bottom of cap parallel to top of cap. Minimum pad heights should be 1" at the edge of pad (or $1\frac{1}{2}''$ if using dowel detail) and cap elevations should be established on this basis. For hammerhead with sloping cap, provide elevation of top of column on both sides of column. For all other sloping caps, provide elevation at top of column on the higher side of each column.
- 3 When cap is horizontal, the top of cap elevation should be established 1" below the lowest pad (or $1\frac{1}{2}''$ if using dowel detail) and dimensioned in the elevation view.
- 4 Where "arriving" and "departing" beam/girders result in calculated differences in pad elevations, the difference is to be applied as follows:

difference = $\frac{1}{8}''$: apply to bolster thickness.

difference > $\frac{1}{8}''$ to $\frac{1}{2}''$: apply to bearing height.

difference > $\frac{1}{2}''$: apply to pad elevations or to superstructure members taking aesthetics into consideration.
- 5 The anchor bolt layout is to be shown in plan view. If dimensions vary, add table.
- 6 Include DOWEL DETAIL for piers/bents with prestressed beams and fixed closure pours.
- 7 Length of PN bars should be determined to obtain a Class A splice with top PC bar.
- 8 For a symmetrical pier cap, reinforcing steel may be shown in half of cap and pier labeled "Symmetrical about this line except as shown (for superelevation) (etc.)."
- 9 Use minimum of 3".
- 10 Use minimum of 1" unless bearing layout requires larger cap.
- 11 Space bars to clear anchor bolts or anchor bolt sleeves and to allow ample room for concrete vibrators. To alleviate spacing problems, consider adding another row of bars.
- 12 Hooks in stirrups should be shown at bottom of cap so as to preclude any possible interference with anchor bolts and shall be placed away from exterior corners.
- 13 Dimension must allow for fabrication tolerances for stirrups.
- 14 Length of main column reinforcement shall extend to within 2" of the lowest layer(s) of top main cap bars.
- 15 Use Class B splice for main column reinforcement lap with footing bars.
- 16 Provide bottom of footing elevation to the hundredth of a foot (i.e. not tenths).

PIER DETAILS SAMPLE SHEETS AND DETAILING CHECK LIST CHECK LIST

PART 2
DATE: 30Apr2020
SHEET 6 of 12
FILE NO. 15.03-6

DETAILING CHECK LIST FOR PIERS / BENTS (Continued)

- 17 Footing-to-column bars shall be hooked in footing. These bars shall have 90 degree hooks. However, 180 degree hooks shall be used in footing when 90 degree hooks result in conflict with pile locations. Bars are to rest on bottom mat of main footing reinforcement and shall provide the minimum embedment length into footing. See File Nos. 07.02-2 and -3. Embedment length shall be not less than basic development length for compression.
- 18 Where seat reinforcement is required per File No. 15.02-6, provide typical detail. Space bars to miss anchor bolts and anchor bolt sleeves.
- 19 Main footing bars shall be hooked. One direction shall have 90 degree hooks, and the other direction 180 degree hooks to prevent conflicts at the footing corners. Bars shall be located above piles.
- 20 In the top of footings, in each direction, provide #5 bars at 12" maximum spacing, or a greater amount of steel if required by design.
- 21 For minimum pile embedment, see **AASHTO LRFD Specifications, Article 10.7, with VDOT Modifications, current IIM-S&B-80**. Note the H-piles depicted on File Nos. 15.03-1 and -3 are shown for seismic Zone 1 with no uplift and intermittent uplift respectively.
- 22 Provide the appropriate geotechnical design data in tabular format if not combined with abutment data and provided near front of the plan assembly. For additional information, see File No. 15.01-7.
- 23 Minimum tip elevations are required for pile foundations.
- 24 Where architectural treatment(s) is used, provide limits of architectural texture, coping widths, texture grid scales, relief, treatment position and other necessary details as applicable. See Chapter 5 of this manual for requirements, details and information for architectural treatment.

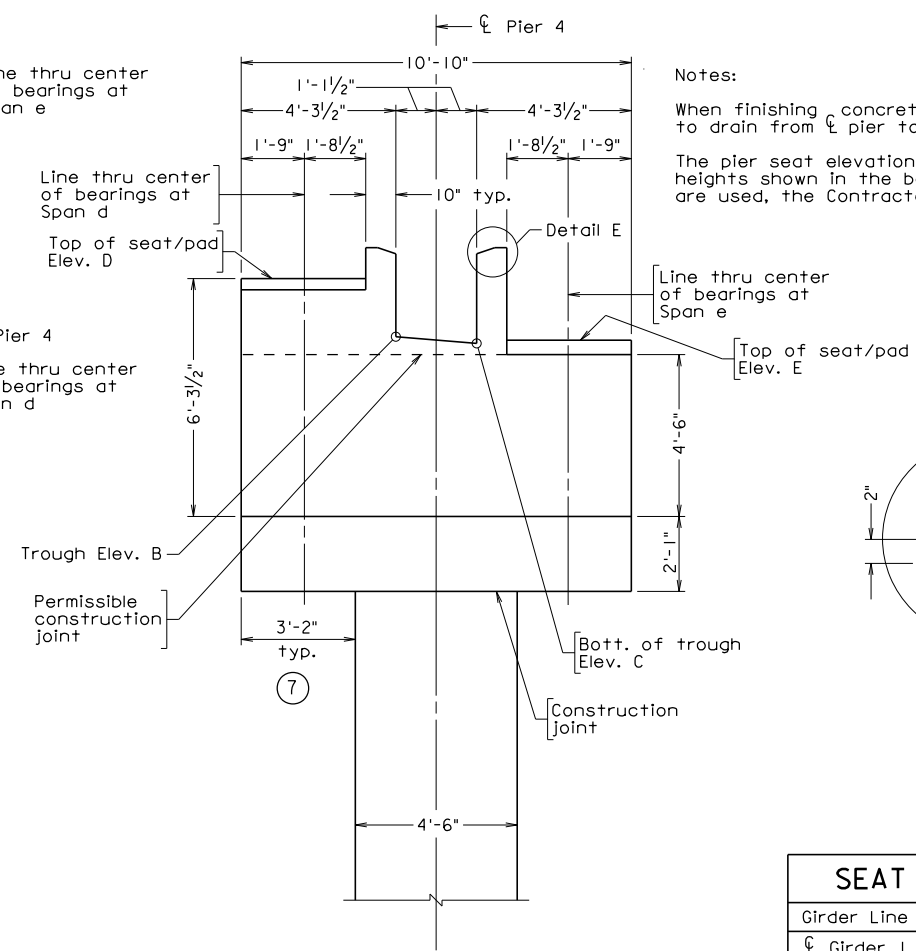
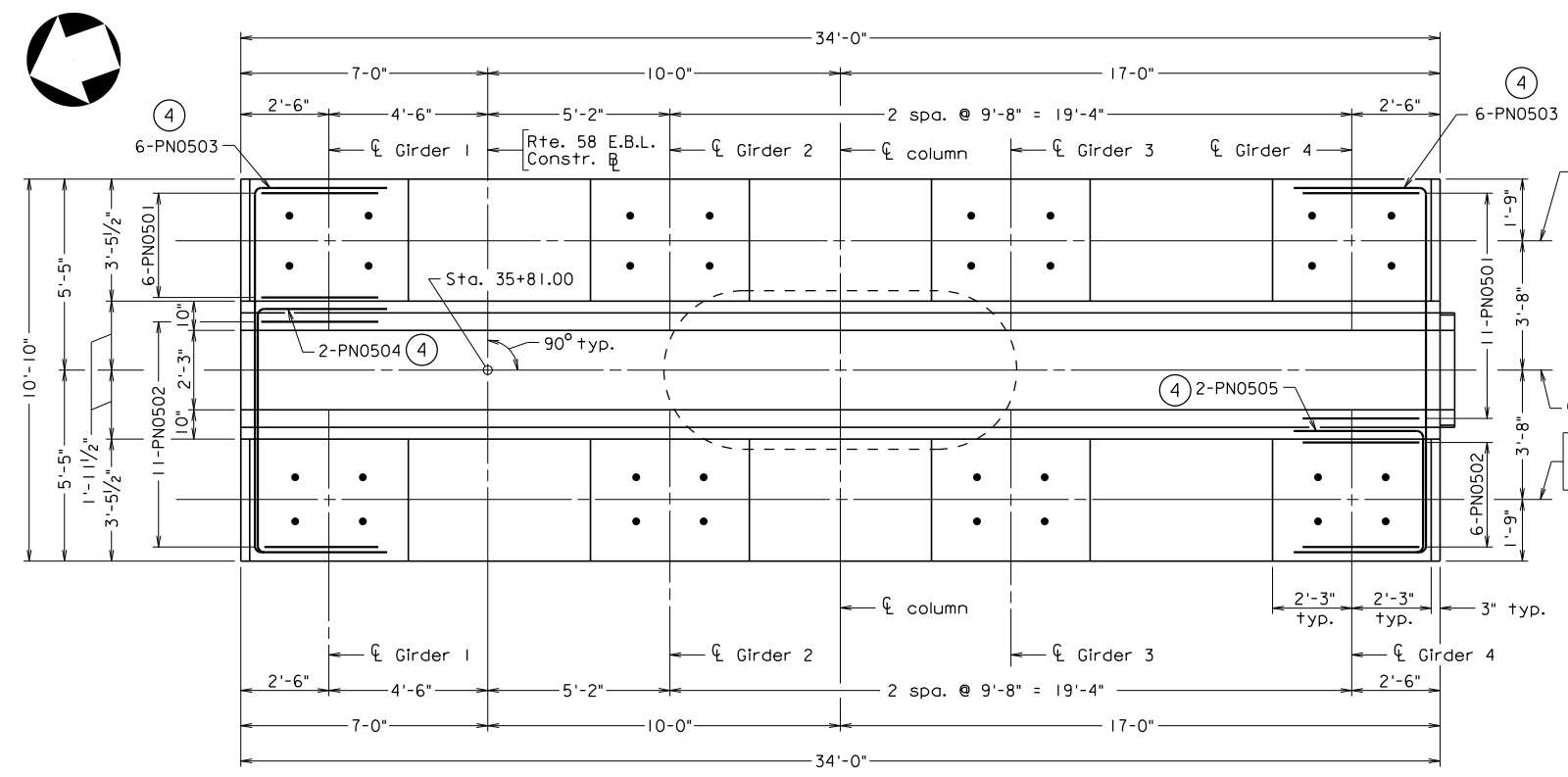

Notes:
 When finishing concrete between and beyond pads, float surface to drain from center of pier to edges of cap.
 The pier seat elevations were determined based on the bearing heights shown in the bearing details. If different bearing heights are used, the Contractor shall adjust the seat elevations.

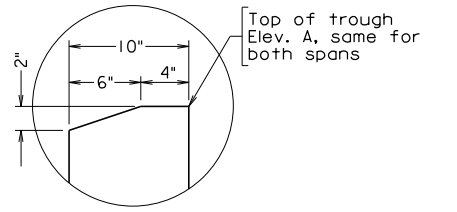

SEAT / TROUGH ELEVATIONS

Girder Line	Elev. A	Elev. B	Elev. C	Elev. D	Elev. E
Centerline Girder 1	407.43	406.48	406.29	406.51	404.71
Centerline Girder 2	407.09	405.68	405.49	406.16	404.39
Centerline Girder 3	406.75	404.87	404.68	405.82	404.06
Centerline Girder 4	406.42	404.07	403.88	405.47	403.76

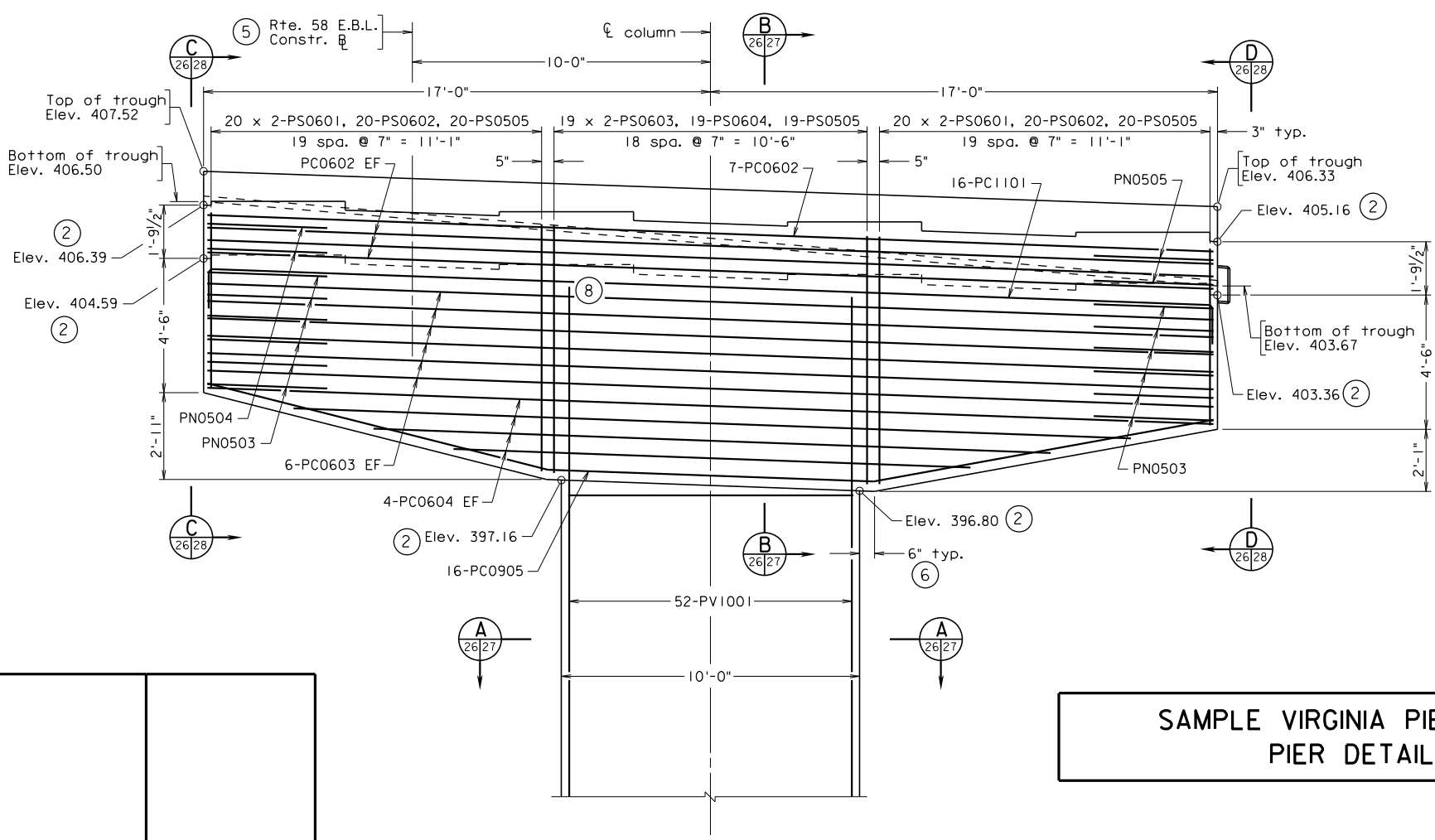

SAMPLE VIRGINIA PIER SHEET
PIER DETAILS

Scale: 3/8" = 1'-0" unless otherwise noted

			COMMONWEALTH OF VIRGINIA DEPARTMENT OF TRANSPORTATION	
			STRUCTURE AND BRIDGE DIVISION	
			PIER 4 PLAN AND ELEVATIONS	
No.	Description	Date	Designed: SUB	Date
			Drawn: SUB	Apr. 2020
			Checked: SUB	999
Revisions			Plan	FILE NO. 15.03-8

STATE	FEDERAL AID		STATE		SHEET
ROUTE	PROJECT		ROUTE	PROJECT	NO.
VA.			58	0058-041-116, B629	27

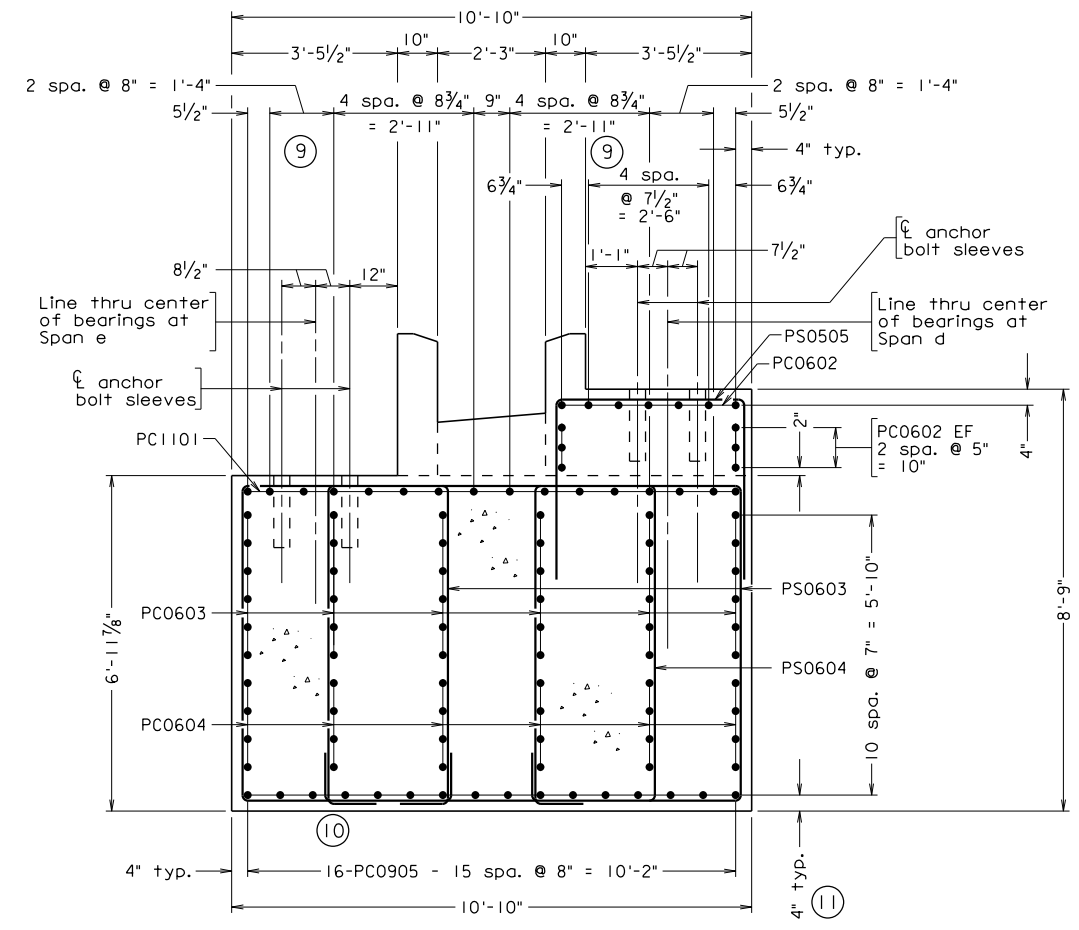

SECTION **B**
Scale: 1/2" = 1'-0"

Notes:
See sheet 26 for plan of cap and pier elevation.
See sheet 28 for seat/pad reinforcement and end of cap reinforcement.
See sheet 29 for drainage trough reinforcement and waterproofing details.

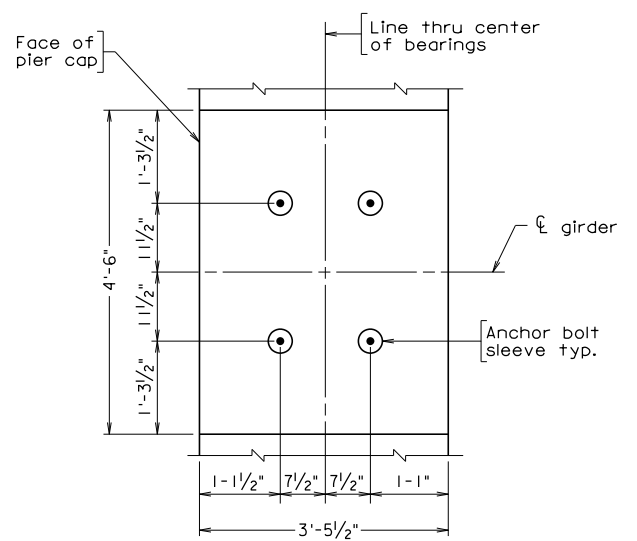

TYPICAL ANCHOR BOLT LAYOUT **12**
SPAN D

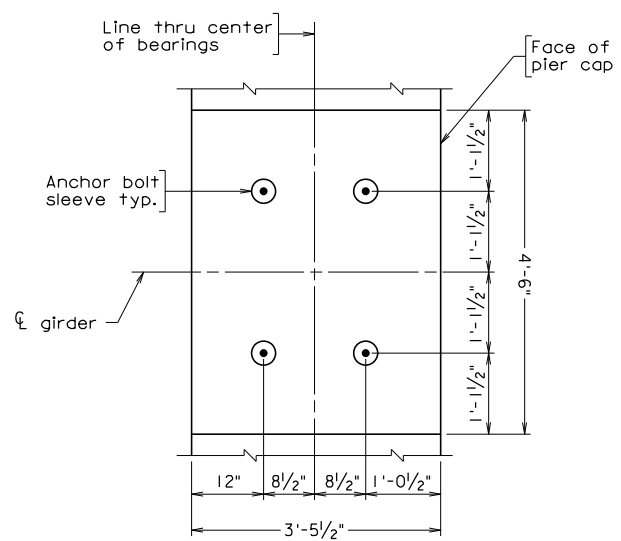

TYPICAL ANCHOR BOLT LAYOUT **12**
SPAN E

**SAMPLE VIRGINIA PIER SHEET
PIER DETAILS**

1
Scale: 3/4" = 1'-0" unless otherwise noted

			COMMONWEALTH OF VIRGINIA DEPARTMENT OF TRANSPORTATION	
			STRUCTURE AND BRIDGE DIVISION	
			PIER 4 FOOTING PLAN, SECTIONS AND DETAILS	
No.	Description	Date	Designed: SUB..... Date:	Plan:
Revisions			Checked: SUB..... Date: Apr. 2020	999
			PART 2 DATE: 30Apr2020 SHEET 9 of 12 FILE NO. 15.03-9	

999-99-027.dgn

STATE	FEDERAL AID	STATE	SHEET NO.
ROUTE	PROJECT	ROUTE	PROJECT
VA.		58	0058-041-116, B629
			28

Notes:
 See sheet 26 for plan of cap and pier elevation.
 See sheet 27 for anchor bolt details and cap reinforcement details.

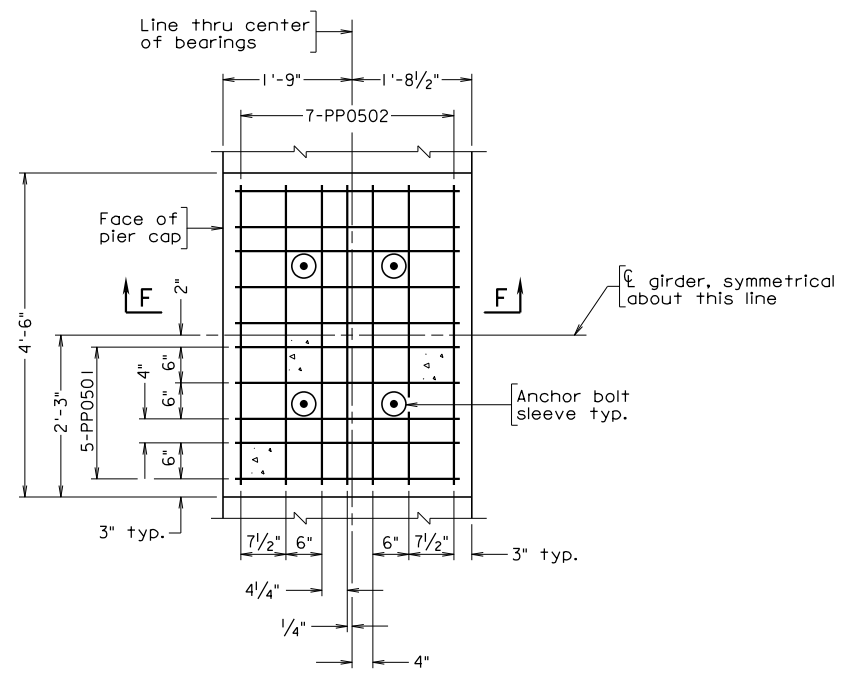

TYPICAL SEAT/PAD REINFORCEMENT - SPAN D (13)
 Scale: 3/4" = 1'-0"

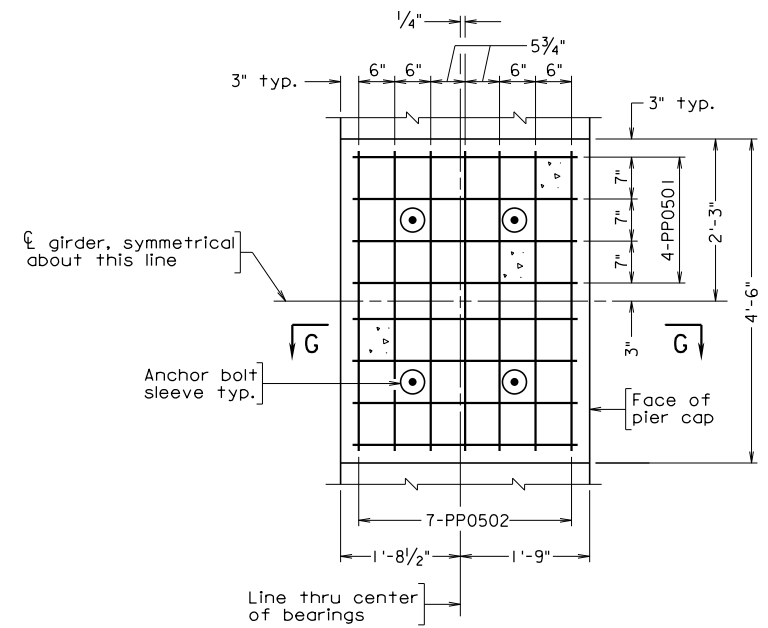

TYPICAL SEAT/PAD REINFORCEMENT - SPAN E (13)
 Scale: 3/4" = 1'-0"

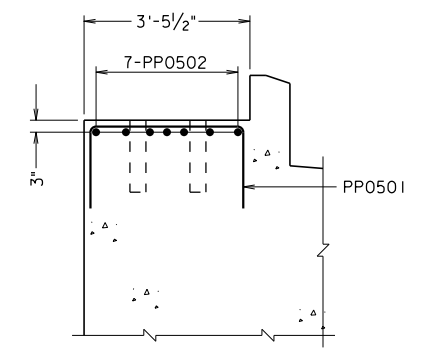

SECTION F-F

Pier cap main reinforcement omitted for clarity

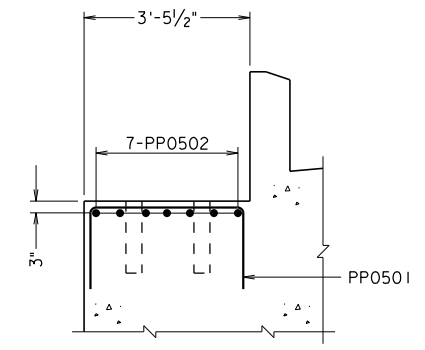

SECTION G-G

Pier cap main reinforcement omitted for clarity

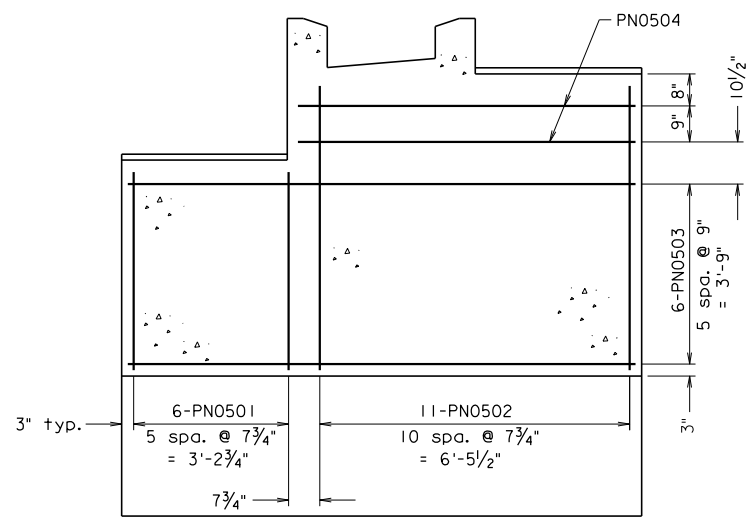

CAP END VIEW C (14)

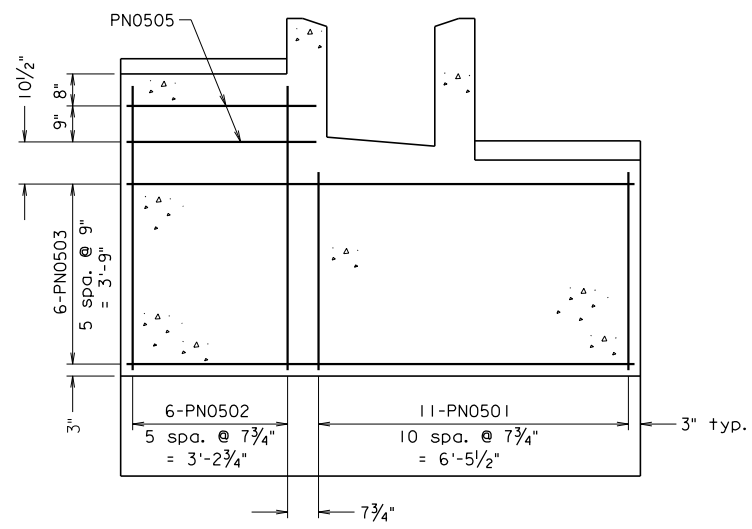

CAP END VIEW D (14)

**SAMPLE VIRGINIA PIER SHEET
 PIER DETAILS**

Scale: 1/2" = 1'-0" unless otherwise noted

© 2020, Commonwealth of Virginia

			COMMONWEALTH OF VIRGINIA DEPARTMENT OF TRANSPORTATION		
			STRUCTURE AND BRIDGE DIVISION		
			PIER 4 SECTIONS AND DETAILS		
No.	Description	Date	Designed: SUB	Date	Plan
			Drawn: SUB	Apr. 2020	999
			Checked: SUB		
Revisions			PART 2 DATE: 30Apr2020 SHEET 10 of 12 FILE NO. 15.03-10		

999-99-028.dgn

VDOT S&B DIVISION
 RICHMOND, VA
 STRUCTURAL ENGINEER

STATE	FEDERAL AID	STATE	SHEET
ROUTE	PROJECT	ROUTE	NO.
VA.		58	29
		0058-041-116, B629	

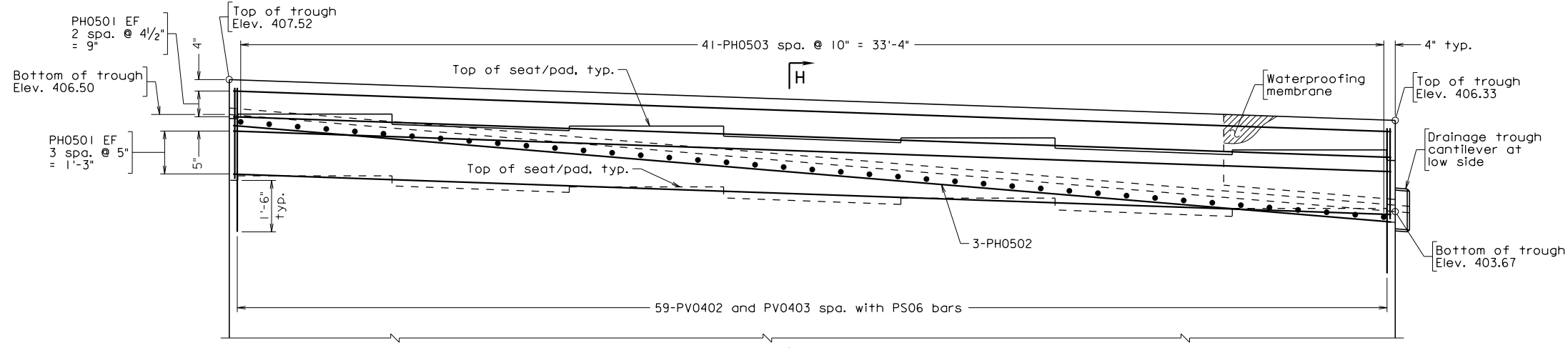

PIER CAP PARTIAL ELEVATION (15)

Notes:
 See sheet 26 for plan of cap and pier elevation.
 See sheet 27 for anchor bolt details and cap reinforcement details.
 Epoxy-Resin Type EP-3B shall be the prime or base coat. Type EP-3T shall be the finish coat. Epoxy-Resin materials shall comply with Section 243 of the Specifications.
 Surface preparation, mixing, application and curing shall be in accordance with Section 416 of the Specifications as applicable to Type EP-3 Epoxy-Resin. The application of sand on the wet surface will not be required.

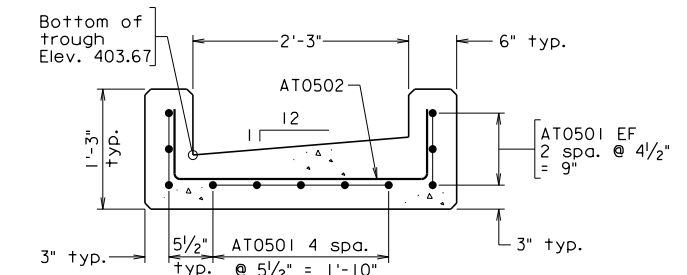

SECTION J-J
Scale: 1" = 1'-0"

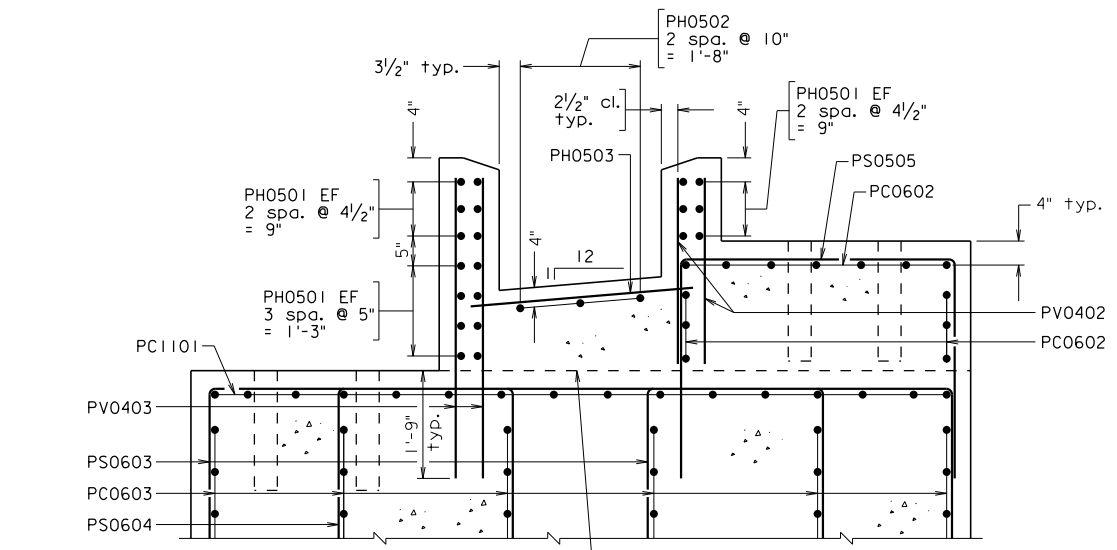

SECTION H-H
Scale: 3/4" = 1'-0"

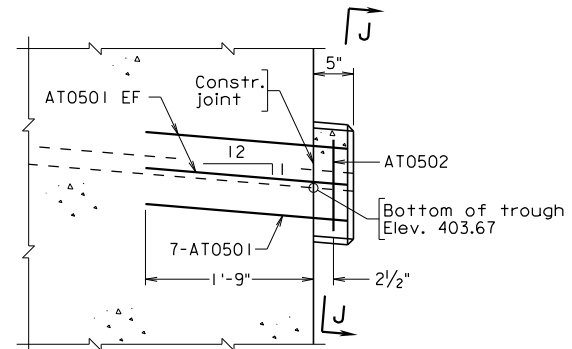

DRAINAGE TROUGH CANTILEVER DETAIL (16)
Scale: 1" = 1'-0"

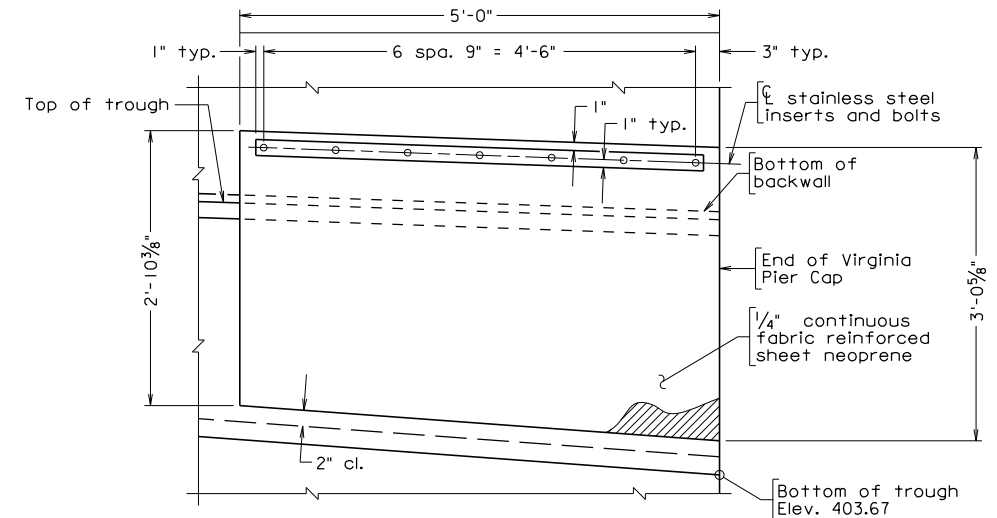

WATERPROOFING MEMBRANE DETAIL (16)
Drainage trough cantilever omitted for clarity
Scale: 1" = 1'-0"

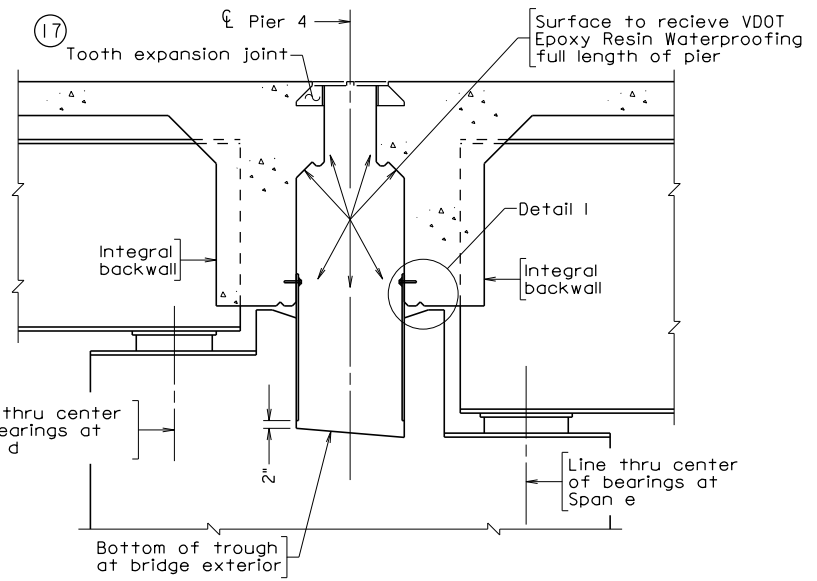

TROUGH WATERPROOFING DETAIL (16)
Not to Scale

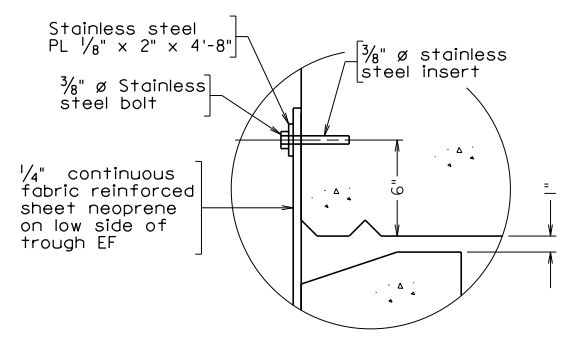

DETAIL I
Not to Scale

**SAMPLE VIRGINIA PIER SHEET
PIER DETAILS**

Scale: 1/2" = 1'-0" unless otherwise noted

© 2020, Commonwealth of Virginia

			COMMONWEALTH OF VIRGINIA DEPARTMENT OF TRANSPORTATION	
			STRUCTURE AND BRIDGE DIVISION	
			PIER 4 SECTIONS AND MISC. DETAILS	
No.	Description	Date	Designed: SUB	Date
			Drawn: SUB	Apr. 2020
			Checked: SUB	999
Revisions			Plan	PART 2 DATE: 30Apr2020 SHEET 11 of 12 FILE NO. 15.03-11

999-99-029.dgn

VDOT S&B DIVISION
RICHMOND, VA
STRUCTURAL ENGINEER

DETAILING CHECK LIST FOR VIRGINIA PIER

- 1 Show Plan of Cap, Elevation, End View and (Typical) Footing Plan at a scale of $\frac{3}{8}'' = 1'-0''$, but no smaller than $\frac{1}{4}'' = 1'-0''$. Show remaining details at a scale of $\frac{3}{4}'' = 1'-0''$, but no smaller than $\frac{1}{2}'' = 1'-0''$.
- 2 Slope cap from end-to-end when seat heights of 4" or more can be avoided. Slope bottom of cap parallel to top of cap. Minimum pad heights should be 1" at the edge of pad and cap elevations should be established on this basis. For sloping cap, provide elevation at top of column (and cap) on both lower and higher sides.
- 3 Provide drainage trough and pad/seat elevations in tabular format.
- 4 Length of PN bars should be determined to obtain a Class A splice with top PC bar.
- 5 Label the location of centerline/baseline as shown on the title sheet. For a symmetrical pier cap, reinforcing steel may be shown in half of cap and pier labeled "Symmetrical about this line except as shown (for superelevation) (etc.)."
- 6 Use minimum of 3".
- 7 Use minimum of 3'-2" unless bearing layout requires larger cap.
- 8 Length of main column reinforcement shall extend to within 2" of the lowest layer(s) of top main cap bars.
- 9 Space bars to clear anchor bolts or anchor bolt sleeves and to allow ample room for concrete vibrators. To alleviate spacing problems, consider adding another row of bars.
- 10 Hooks in stirrups should be shown at bottom of cap so as to preclude any possible interference with anchor bolts and shall be placed away from exterior corners.
- 11 Dimension must allow for fabrication tolerances of stirrups.
- 12 The anchor bolt layout is to be shown in plan view. If dimensions vary, add table if needed.
- 13 Where seat/pad reinforcement is required per File No. 15.02-6, provide typical detail(s) with size and spacing of reinforcing steel.
- 14 Show Cap End View complete with size and spacing of nose reinforcing steel at a scale of $\frac{1}{2}'' = 1'-0''$ unless space is insufficient to show adequate details.
- 15 Show Pier Cap Partial Elevation of trough complete with location of waterproofing membrane and trough reinforcing steel at a scale of $\frac{1}{2}'' = 1'-0''$ unless space is insufficient to show adequate details. Waterproofing membrane shall be located at the low side(s) of trough as shown in File No. 15.01.4 and -5.
- 16 Show miscellaneous details, e.g. DRAINAGE TROUGH CANTILEVER DETAILS, TROUGH WATERPROOFING DETAILS and WATERPROOFING MEMBRANE DETAILS.
- 17 Include standard sheet(s) in the plan assembly for appropriate joint type. For specific requirements and guidelines for completing those standard detail sheets, refer to the Notes to Designer for the particular standard contained in Part 3 of this manual.

PIER DETAILS SAMPLE SHEETS AND DETAILING CHECK LIST CHECK LIST

PART 2
DATE: 30Apr2020
SHEET 12 of 12
FILE NO. 15.03-12

GENERAL INFORMATION:

Forces on the superstructure are transferred to the substructure through the bearings. Bearing design, joint design, unit length (i.e. length of continuous spans between joints) and subsurface conditions affect pier design and a holistic approach is required to ensure the bridge functions properly.

Expansion bearings transmit forces to the substructure due to movement of the bearing. Fixed bearings are attached to the substructure to prevent movement between the superstructure and the substructure. However, the substructure may deflect based on its stiffness and the force transferred from the superstructure. The substructure must be designed for the forces from any type of bearing.

Grade (vertical profile) effects can typically be ignored in design.

Wind and Braking Forces on Superstructure:

Wind forces on the superstructure and live load can have both a transverse and longitudinal component. These forces are computed for various skew angles of wind perpendicular to the longitudinal direction of the bridge. Thus 0 degree skew angle is perpendicular to the bridge and consists of the largest transverse force wind pressure.

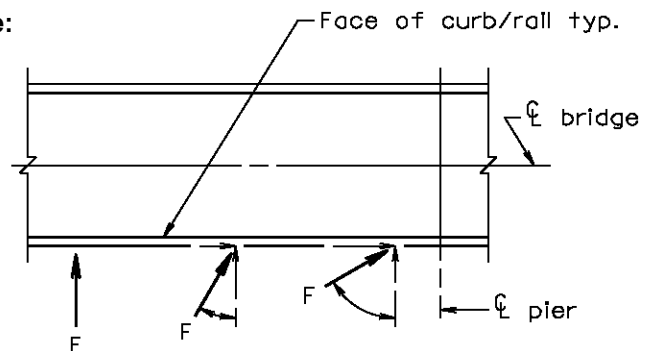

0 Degree 30 Degree 60 Degree

Wind on Superstructure and Live Load

Braking Force (Traction) consists of only a longitudinal force on a straight bridge, but will have a transverse component on a curved bridge due to centrifugal force.

Longitudinal forces and transverse forces are typically distributed among the number of bearings fixed in that direction. For example, on a straight four-span bridge with fixed bearings at Pier 2 and guided expansion (slotted) bearings at the abutments and Piers 1 and 3, Pier 2 should conservatively be designed for all the longitudinal force. Piers 1, 2 and 3 should be designed for their portion of the transverse force (i.e., one-half span back and one-half span up station). The design of Piers 1 and 3 would include longitudinal temperature and shrinkage forces, where applicable, and Pier 2 any unbalance force as discussed below.

Temperature (Expansion, Contraction) and Shrinkage Forces (where applicable):

Expansion/contraction of the superstructure develops forces which are transferred to the substructure through the bearings. Bridges with concrete superstructures must also be designed for shrinkage. A shrinkage coefficient of 0.0003 may be used except for segmentally constructed bridges. For typical multi-beam/girder prestressed concrete superstructures not integral with the substructure, the shrinkage coefficient can be considered to include superstructure creep effects.

GENERAL INFORMATION (Continued):

Temperature (Expansion, Contraction) and Shrinkage Forces (where applicable):

The total design movement at each bent/pier shall be 0.65 times the design thermal movement range. The design thermal movement range shall be obtained from AASHTO LRFD specifications, Table 3.12.2.1-1 using the moderate climate range for steel superstructures (120 °F) and the cold climate range for concrete superstructures (80 °F). See current IIM-S&B-80. Therefore, +/- 78 °F should be used to determine temperature forces for pier/bent design for steel superstructures and +/- 52 °F for concrete superstructures. A 52 °F contraction combined with shrinkage will control for concrete superstructures. Where elastomeric expansion bearings are used, the maximum elastomeric shearing resistance shall be used to determine temperature and shrinkage forces.

On a two-span continuous symmetric structure with fixed bearings at the pier, the temperature and shrinkage (where applicable) force would be zero at the pier. With unsymmetric spans, an unbalanced force will exist due to the unbalanced expansion lengths and/or bearing design.

Similarly for three or more span continuous symmetric structures with fixed bearings at the middle pier(s), the thermal center (neutral point) can be considered the center. However, relative stiffness between piers may shift the thermal center of a bridge and/or create unbalanced forces at fixed piers.

When pier/bent heights differ by more than 25 percent between piers/bents within a continuous structural unit, the designer shall take into account the effects of substructure stiffness when determining the expansion length at any point (including joints) and the forces to be resisted at any substructure unit. Pier height is measured from the top of footing to the top of cap. For pile bents, height is measured from the assumed point of pile fixity to the top of cap. See Example 1.

When the summation of span lengths left or right of a fixed pier differ more than 25 percent, the designer shall take into account the effects of unsymmetric spans when determining the expansion length at any point (including joints) and the forces to be resisted at any substructure unit. See Example 2.

The design of pile bents is further complicated in that the magnitude of the temperature and shrinkage (where applicable) forces directly affects the location of the assumed point of fixity for the pile along with varying geotechnical conditions at each location. See Example 3.

Pier programs typically apply load factors internally. The load factors for force effects for Uniform Temperature, TU, and Shrinkage, SH, in the strength limit state depend on whether I_g or $I_{effective}$ was used to derive forces and are the same for both. Designers shall ensure that the appropriate load factors from AASHTO LRFD Article 3.4.1 are used in pier program runs for TU and SH.

All three examples use simplified analysis in conjunction with the gross moment of inertia for the pier columns. As such, a load factor of 0.5 and 1.0 would be used for strength and service limit states respectively for both TU and SH for load combinations within the pier program. Since the load factors are the same, TU and SH are considered together in the examples and the combined force is intended to be input as TU in the pier program.

Bridges with curved girders, skews greater than 20 degrees, integral piers, and/or column/pile lengths varying by more than 50 percent between extremes within an individual pier/bent should be modeled using a finite element analysis program to determine overall structure behavior due to thermal and other loads before designing piers, bearings or joints.

Bridge Layout:

To obtain a satisfactory and efficient bridge design, the distribution of wind and traction forces needs to be balanced against the temperature and shrinkage demands. If too many piers are fixed, the temperature and shrinkage forces for the fixed piers will disproportionately control design. If too few are fixed, the wind and traction forces will disproportionately control design.

Joint type and size, where applicable, should be determined considering the overall bridge or unit temperature and shrinkage modeling.

Where temperature and shrinkage forces in the exterior piers/bents of a unit are too large or control column/pile size, various methods may be used to reduce forces. Increasing the elastomer thickness for elastomeric bearings or switching to slip bearings with low friction coefficients can lower design forces. Oversizing or slotting holes in fixed bearing sole plates can lower design forces by allowing some movement before engaging and facilitate fit-up during erection for steel superstructures. For pile bents, predrilling and placing select backfill around the pile once it is in place can lower the assumed point of fixity by increasing the pile flexibility and reducing the temperature/shrinkage forces. Adding a joint should only be done when all options are exhausted.

**PIER DETAILS
SUPERSTRUCTURE FORCES
GENERAL INFORMATION**

PART 2
DATE: 17Dec2010
SHEET 3 of 12
FILE NO. 15.04-3

EXAMPLE 1: Hammerhead pier on spread/pile footing of varying height

This example consists of a 4-span continuous prestressed Bulb-T bridge with semi-integral abutments. Elastomeric bearings are used and dimensions shown in the calculation table are those from the final bearing designs. The preliminary hammerhead pier design uses a 5'-0" by 11'-0" column with circular ends. The superstructure typical section consists of 5 beam lines. Skew = 0°.

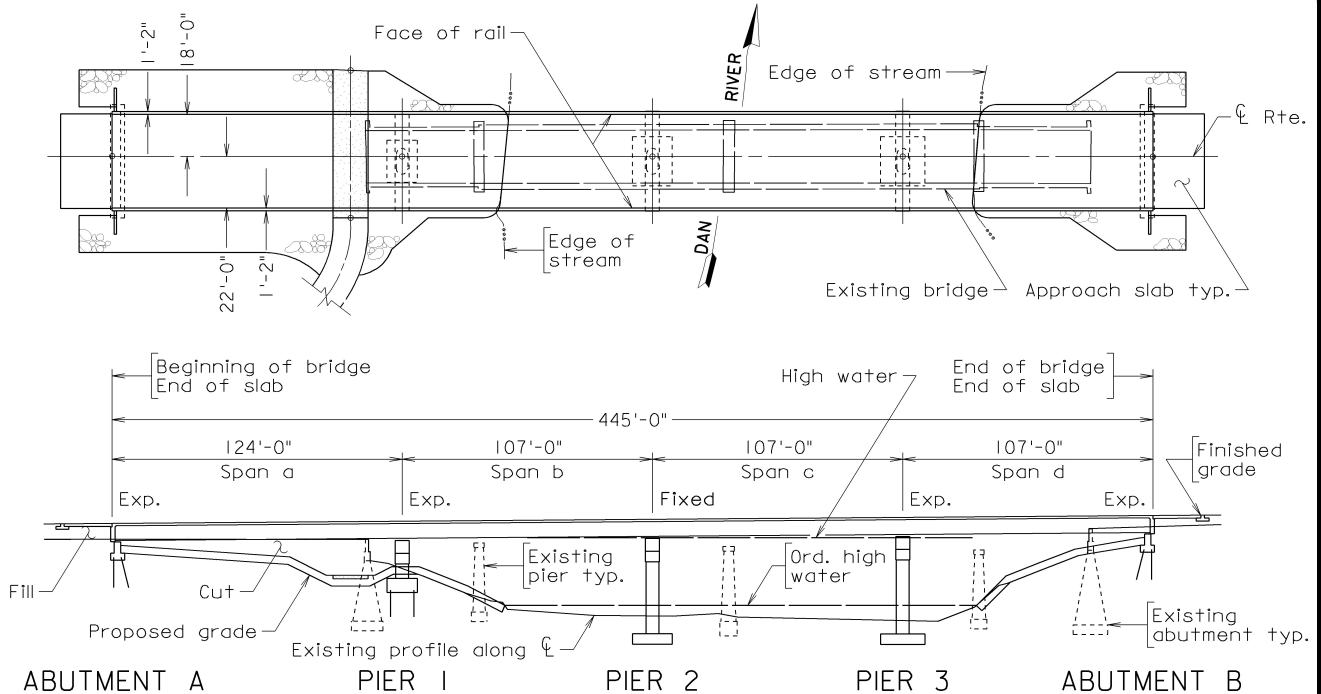

Sample calculations for the temperature loads are provided below and on the following sheet. Note that the thermal center of the bridge was determined by an iterative process (i.e. adjusting the position of the thermal center until opposing forces balance) and is located 14 feet to the left of Pier 2. Elastomeric deformation, Δ_{elast} , was also determined by an iterative process for each expansion pier (i.e. adjusting the value until the summation of the elastomeric deformation and pier deflection equals the total movement required).

Variables and equations:

∂ = coefficient of thermal expansion/contraction for normal weight concrete = 0.000006 per °F

ΔT = Temperature change, °F = 0.65 x 80 °F = 52 °F

L = Length from thermal center of bridge, feet

L_{elast} = Length of elastomeric bearing pad, inches

W_{elast} = Width of elastomeric bearing pad, inches

G_{max} = maximum elastomeric shearing resistance (range = 95 to 130 psi) = 0.130 ksi

Example continued on next sheet

PIER DETAILS SUPERSTRUCTURE FORCES EXAMPLE 1: VARYING HEIGHT/STIFFNESS

PART 2
DATE: 11Jan2011
SHEET 4 of 12
FILE NO. 15.04-4

EXAMPLE 1: Hammerhead pier on spread/pile footing of varying height (cont'd.)

Variables and equations (continued):

N_{pads} = No. of elastomeric bearings (for PS beams continuous for LL, count both bearing lines) = 10

t_{elast} = Total thickness of internal and external elastomeric layers (total pad height – shims), inches

Δ_{elast} = Assumed/actual elastomeric deformation in direction of expansion/contraction, inches

P_{elast} = Force created internally in elastomeric pad for assumed/actual deformation, kips

$$= L_{\text{elast}} \times W_{\text{elast}} \times G_{\text{max}} \times N_{\text{pads}} \times \Delta_{\text{elast}} / t_{\text{elast}}$$

H_{SS} = Top of cap to top of footing (pier on pile or spread footing), feet

f'_c = Column (pile for pile bent) concrete strength = 3,000 psi

E_c = Modulus of elasticity for concrete, psi

$$= w_c^{1.5} \times 33 \times f'_c^{0.5} = 145^{1.5} \times 33 \times 3000^{0.5} = 3,156,000 \text{ psi}$$

I_c = Uncracked moment of inertia for column(s) (piles for pile bent), in⁴

$$= [72'' \times (60'')^3 / 12] + [\pi \times (30'')^4 / 4] = 1,932,200 \text{ in}^4$$

P_{SS} = Force required to deflect substructure required distance at fixed pier/bent, kips

$$= 3 \times E_c \times I_c \times \Delta_{\text{temp}} / (H_{\text{SS}} \times 12)^3$$

Δ_{SS} = Substructure deflection in direction of exp./contraction, inches = $P_{\text{elast}} \times (H_{\text{SS}} \times 12)^3 / (3 \times E_c \times I_c)$

Δ_{temp} = Total movement required at pier/bent including shrinkage [prestressed superstructure], inches

$$= (\partial \times L \times \Delta T \times 12) + (0.0003 \times L \times 12)$$

Sample calculation:

With longer spans and shorter (stiffer) piers on the left of Pier 2, assume the thermal center of the bridge is 8.5 feet left of Pier 2.

The required movement at Piers 1 and 3 will be a combination of pier deflection and pad distortion. Pier 2 is fixed and the pier must deflect the required movement. The abutments have two rows of piles and are assumed rigid, so the elastomeric pad must distort the required distance.

Using the values found in the calculation table on the following sheet, the numbers for Pier 1 are:

$$\Delta_{\text{temp}} = (\partial \times L \times \Delta T \times 12) + (0.0003 \times L \times 12) = (0.000006 \times 98.5 \times 52 \times 12) + (0.0036 \times 98.5) = 0.723''$$

$$\text{Try } \Delta_{\text{elast}} = 0.600''$$

$$P_{\text{elast}} = L_{\text{elast}} \times W_{\text{elast}} \times G_{\text{max}} \times N_{\text{pads}} \times \Delta_{\text{elast}} / t_{\text{elast}} = 26 \times 10 \times 0.130 \times 10 \times 0.600 / 2.152 = 94.2 \text{ kips}$$

$$\Delta_{\text{SS}} = P_{\text{elast}} \times (H_{\text{SS}} \times 12)^3 / (3 \times E_c \times I_c) = 94.2 \times (13.5 \times 12)^3 / (3 \times 3,156 \times 1,932,200) = 0.022''$$

Example continued on next sheet

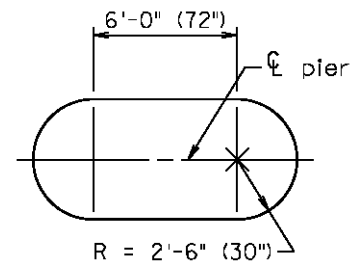

EXAMPLE 1: Hammerhead pier on spread/pile footing of varying height (cont'd.)

Sample calculation (continued):

$$\Delta_{\text{elast}} + \Delta_{\text{SS}} = 0.600'' + 0.022'' = 0.622'' < \Delta_{\text{temp}} = 0.723''$$

Since the summation of Δ_{elast} and Δ_{SS} does not equal Δ_{temp} , try $\Delta_{\text{elast}} = 0.698''$

$$P_{\text{elast}} = L_{\text{elast}} \times W_{\text{elast}} \times G_{\text{max}} \times N_{\text{Opads}} \times \Delta_{\text{elast}} / t_{\text{elast}} = 26 \times 10 \times 0.130 \times 10 \times 0.698 / 2.152 = 109.6 \text{ kips}$$

$$\Delta_{\text{SS}} = P_{\text{elast}} \times (H_{\text{SS}} \times 12)^3 / (3 \times E_c \times I_c) = 109.6 \times (13.5 \times 12)^3 / (3 \times 3,156 \times 1,932,200) = 0.025''$$

$$\Delta_{\text{elast}} + \Delta_{\text{SS}} = 0.698'' + 0.025'' = 0.723'' = \Delta_{\text{temp}}$$

Perform a similar iterative calculation process for Pier 3. Directly compute P_{elast} for both abutments and P_{SS} for Pier 2.

Calculation table (thermal center assumed 8.5 feet left of Pier 2):

	L	L_{elast}	W_{elast}	t_{elast}	Δ_{elast}	P_{elast}	H_{SS}	P_{SS}	Δ_{SS}	Δ_{temp}
Abutment A	220.1	26	16	3.924	1.617	111.4	N/A	N/A	N/A	1.617
Pier 1	98.5	26	10	2.152	0.698	109.6	13.5	N/A	0.025	0.723
Pier 2	8.5	N/A	N/A	N/A	N/A	N/A	37.9	12.1	0.062	0.062
Pier 3	115.5	26	10	2.152	0.456	71.6	38.7	N/A	0.392	0.848
Abutment B	220.1	26	16	3.924	1.617	111.4	N/A	N/A	N/A	1.617

The summation of the shaded columns, Δ_{elast} and Δ_{SS} , must equal the total movement required, Δ_{temp} .

$$111.4 \text{ kips} + 109.6 \text{ kips} = 221.0 \text{ kips} > 12.1 \text{ kips} + 71.6 \text{ kips} + 111.4 \text{ kips} = 195.1 \text{ kips}$$

The thermal center of the bridge is further from Pier 2 in the direction of Abutment A. Recalculate with the thermal center of the bridge 14.5 feet from Pier 2.

Calculation table (thermal center assumed 14.5 feet left of Pier 2):

Location	L	L_{elast}	W_{elast}	t_{elast}	Δ_{elast}	P_{elast}	H_{SS}	P_{SS}	Δ_{SS}	Δ_{temp}
Abutment A	214.1	26	16	3.924	1.573	108.4	N/A	N/A	N/A	1.573
Pier 1	92.5	26	10	2.152	0.651	102.2	13.5	N/A	0.024	0.679
Pier 2	14.5	N/A	N/A	N/A	N/A	N/A	37.9	20.7	0.106	0.106
Pier 3	121.5	26	10	2.152	0.480	75.3	38.7	N/A	0.412	0.892
Abutment B	226.1	26	16	3.924	1.661	114.4	N/A	N/A	N/A	1.661

The summation of the shaded columns, Δ_{elast} and Δ_{SS} , must equal the total movement required, Δ_{temp} .

$$108.4 \text{ kips} + 102.2 \text{ kips} = 210.6 \text{ kips} \approx 20.7 \text{ kips} + 75.3 \text{ kips} + 114.4 \text{ kips} = 210.4 \text{ kips}$$

Note that the resulting temperature and shrinkage force at Pier 1 is 102.2 kips while 75.3 kips at Pier 3. Although Pier 2 is fixed, it is expected to deflect 0.106" to the right and the temperature and shrinkage force is 20.7 kips. Design requirements for all three piers will be relatively balanced as Pier 2 will be designed for a small temperature and shrinkage force, but all the longitudinal wind and braking force. Pier 1 has a larger temperature and shrinkage force, but shorter column length than Pier 3.

PIER DETAILS SUPERSTRUCTURE FORCES EXAMPLE 1: VARYING HEIGHT/THICKNESS

PART 2
DATE: 11Jan2011
SHEET 6 of 12
FILE NO. 15.04-6

EXAMPLE 2: Multi-column pier on footings with unsymmetric spans (cont'd.)

Variables and equations (continued):

L = Length from thermal center of bridge, feet

L_{elast} = Length of elastomeric bearing pad, inches

W_{elast} = Width of elastomeric bearing pad, inches

G_{max} = maximum elastomeric shearing resistance (range = 95 to 130 psi) = 0.130 ksi

N_{opads} = No. of elastomeric bearings (for PS beams continuous for LL, count both bearing lines) = 5

t_{elast} = Total thickness of internal and external elastomeric layers (total pad height – shims), inches

Δ_{elast} = Assumed/actual elastomeric deformation in direction of expansion/contraction, inches

P_{elast} = Force created internally in elastomeric pad for assumed/actual deformation, kips

$$= L_{elast} \times W_{elast} \times G_{max} \times N_{opads} \times \Delta_{elast} / t_{elast}$$

H_{ss} = Top of cap to top of footing (pier on pile or spread footing), feet

f'_c = Column (pile for pile bent) concrete strength = 4,000 psi

E_c = Modulus of elasticity for concrete, psi = $w_c^{1.5} \times 33 \times f'_c^{0.5} = 145^{1.5} \times 33 \times 4000^{0.5} = 3,644,000$ psi

I_c = Uncracked moment of inertia for column(s) (piles for pile bent), in⁴

$$= 3 \times \pi \times (24")^4 / 4 = 781,700 \text{ in}^4$$

P_{SS} = Force required to deflect substructure required distance at fixed pier/bent, kips

$$= 3 \times E_c \times I_c \times \Delta_{temp} / (H_{SS} \times 12)^3$$

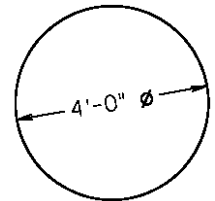

Δ_{SS} = Substructure deflection in direction of exp./contraction, inches = $P_{elast} \times (H_{SS} \times 12)^3 / (3 \times E_c \times I_c)$

Δ_{temp} = Total movement required at pier/bent [steel superstructure, no shrinkage], inches

$$= \delta \times L \times \Delta T \times 12$$

Calculation table (Right of longitudinal joint): Thermal center determined to be 63.75' left of Pier 2

Location	L	L_{elast}	W_{elast}	t_{elast}	Δ_{elast}	P_{elast}	H_{ss}	P_{SS}	Δ_{SS}	Δ_{temp}
Abutment A	241.25	18	18	4.434	1.468	69.7	N/A	N/A	N/A	1.468
Pier 1	112.50	22	22	2.147	0.375	55.0	30.3	N/A	0.309	0.684
Pier 2	63.50	24	24	2.522	0.220	32.7	29.3	N/A	0.166	0.386
Abutment B	231.18	22	22	4.804	1.407	92.1	N/A	N/A	N/A	1.407

The summation of the shaded columns, Δ_{elast} and Δ_{SS} , must equal the total movement required, Δ_{temp} .

$$69.7 \text{ kips} + 55.0 \text{ kips} = \mathbf{124.7 \text{ kips}} \quad \approx \quad 32.7 \text{ kips} + 92.1 \text{ kips} = \mathbf{124.8 \text{ kips}}$$

PIER DETAILS SUPERSTRUCTURE FORCES EXAMPLE 2: UNSYMMETRIC SPANS

PART 2
DATE: 11Jan2011
SHEET 8 of 12
FILE NO. 15.04-8

EXAMPLE 3: PILE BENT

Pile bents and drilled shafts have an additional consideration when compared to columns on spread or pile footings. The geotechnical conditions at each location require modeling and the magnitude of the forces directly affects the location of the assumed point of fixity for the pile/shaft.

This example consists of a 10-span continuous prestressed Bulb-T bridge with semi-integral abutments at both ends. Elastomeric bearings will be used. Due to the length of the bridge elastomeric bearings with a PTFE sliding surface will be used at the abutments. The preliminary pile bent designs consist of 24" square prestressed concrete piles with seven piles per bent. Skew = 0°.

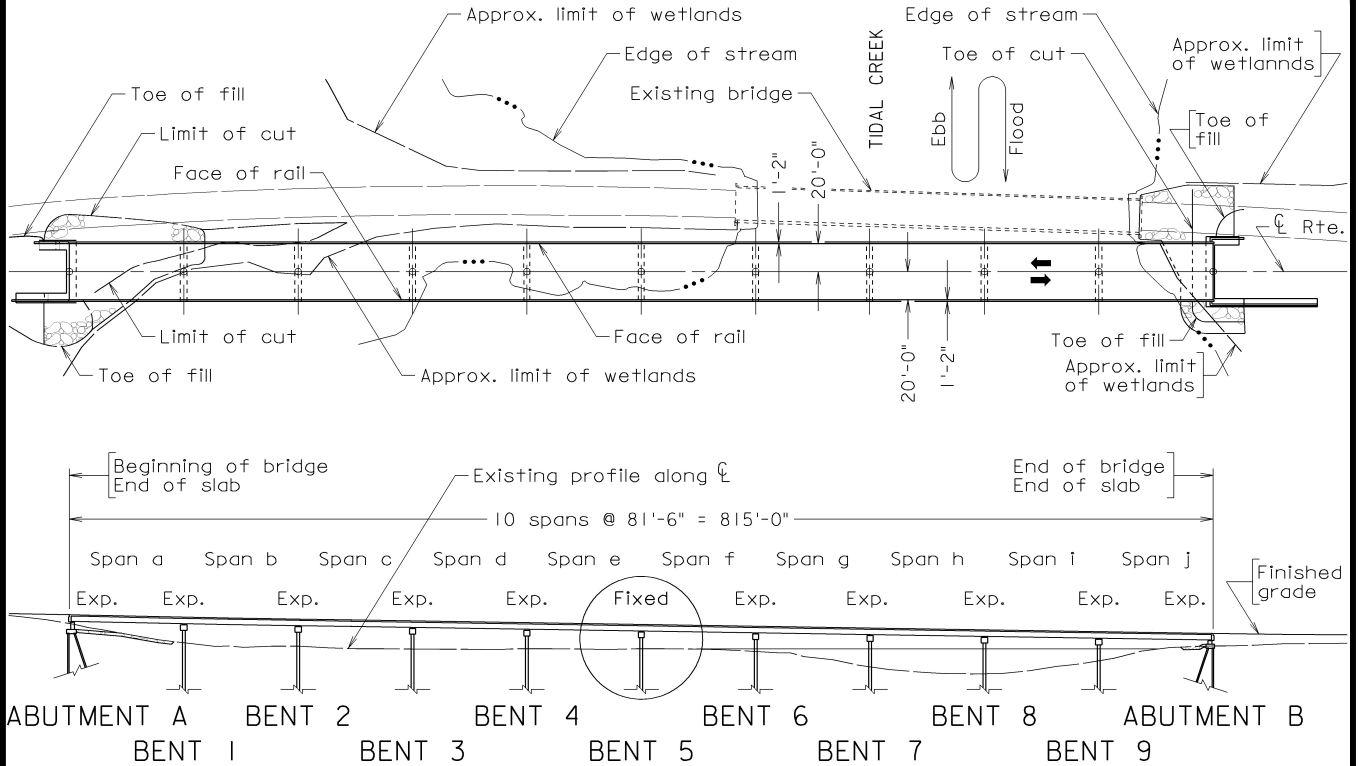

Applying all the longitudinal forces to Bent 5 will likely be infeasible. Fixing three piers may provide an efficient design. This example spreads the load further by fixing five piers as shown below. Check to ensure that the piles can handle the forces generated by forcing them to displace for temperature and shrinkage. Slip bearings exist at both abutments and should not be part of the unit modeling. Passive pressure will develop at both abutments, but can be neglected since EPS is used behind the backwall.

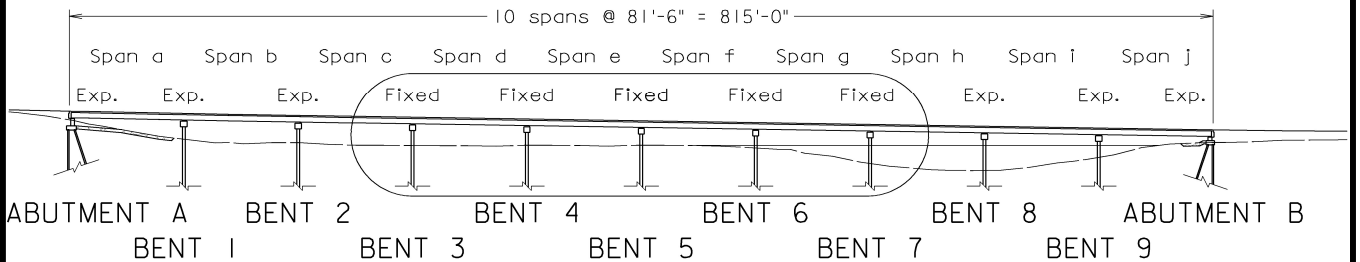

Example continued on next sheet

PIER DETAILS SUPERSTRUCTURE FORCES EXAMPLE 3: PILE BENT

PART 2
DATE: 17Dec2010
SHEET 9 of 12
FILE NO. 15.04-9

EXAMPLE 3: PILE BENT (cont'd.)

The assumed point of fixity (POF) is dependent on the geotechnical data at each bent location and is sensitive to the horizontal force exerted on the piles. In the sketch below, the points of fixity for the piles are derived by modeling the geotechnical data in the L-Pile compute program for the calculated forces. This is an iterative process in which POF's are assumed, forces calculated and then entered into L-Pile. The new POF's resulting from the L-Pile run are input back into the model and the process repeated until closure.

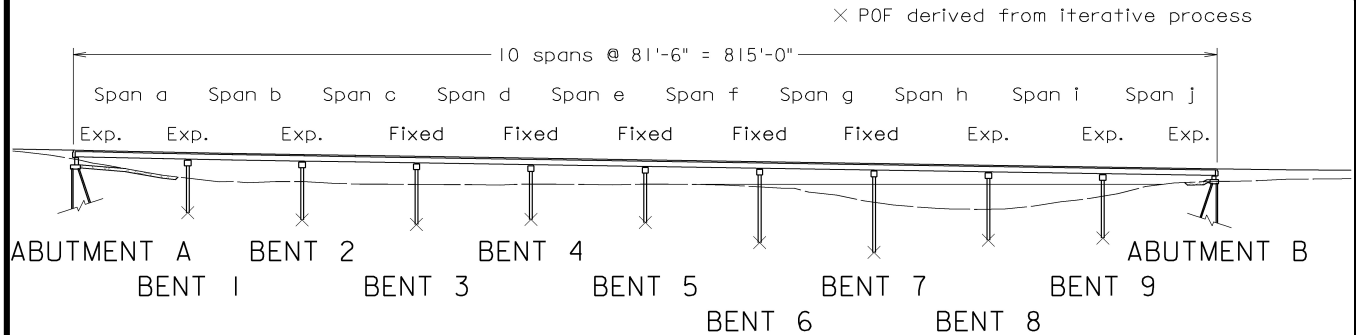

Sample calculations for the temperature loads in the scoured condition are provided below and continued on the next sheet for the sketch above.

Variables and equations:

δ = coefficient of thermal expansion/contraction for normal weight concrete = 0.000006 per °F

ΔT = Temperature change, °F = 0.65 x 80 °F = 52 °F

L = Length from thermal center of bridge, feet

L_{elast} = Length of elastomeric bearing pad, inches

W_{elast} = Width of elastomeric bearing pad, inches

G_{max} = maximum elastomeric shearing resistance (range = 95 to 130 psi) = 0.130 ksi

NO_{pads} = No. of elastomeric bearings (for PS beams continuous for LL, count both bearing lines) = 10

t_{elast} = Total thickness of internal and external elastomeric layers (total pad height – shims), inches

Δ_{elast} = Assumed/actual elastomeric deformation in direction of expansion/contraction, inches

P_{elast} = Force created internally in elastomeric pad for assumed/actual deformation, kips

$$= L_{elast} \times W_{elast} \times G_{max} \times NO_{pads} \times \Delta_{elast} / t_{elast}$$

H_{ss} = Top of cap to assumed point of fixity for piles (pile bent), feet

f'_c = Column (pile for pile bent) concrete strength = 5,000 psi

Example continued on next sheet

PIER DETAILS SUPERSTRUCTURE FORCES EXAMPLE 3: PILE BENT

PART 2
DATE: 11Jan2011
SHEET 10 of 12
FILE NO. 15.04-10

EXAMPLE 3: PILE BENT (cont'd.)

Variables and equations (continued):

E_c = Modulus of elasticity for concrete, psi = $w_c^{1.5} \times 33 \times f'_c^{0.5} = 145^{1.5} \times 33 \times 5000^{0.5} = 4,074,000$ psi

I_c = Uncracked moment of inertia for column(s) (piles for pile bent), in⁴

$$= 7 \text{ piles} \times [24'' \times (24'')^3 / 12] = 193, 536 \text{ in}^4$$

P_{SS} = Force required to deflect substructure required distance at fixed pier/bent, kips

$$= 3 \times E_c \times I_c \times \Delta_{temp} / (H_{SS} \times 12)^3$$

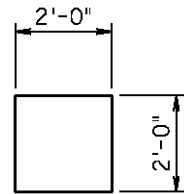

Δ_{SS} = Substructure deflection in direction of expansion/contraction, inches

$$= P_{elast} \times (H_{SS} \times 12)^3 / (3 \times E_c \times I_c)$$

Δ_{temp} = Total movement required at pier/bent including shrinkage [prestressed superstructure], inches

$$= (\partial \times L \times \Delta T \times 12) + (0.0003 \times L \times 12)$$

Calculation table (Scoured):

Location	L	L_{elast}	W_{elast}	t_{elast}	Δ_{elast}	P_{elast}	H_{ss}	PSS	Δ_{ss}	Δ_{temp}
Bent 1	277.0	25	19	5.279	0.422	49.3	35.5	N/A	1.612	2.034
Bent 2	195.5	22	15	4.043	0.255	27.1	39.1	N/A	1.181	1.436
Bent 3	114.0	N/A	N/A	N/A	N/A	N/A	41.1	16.5	0.837	0.837
Bent 4	32.5	N/A	N/A	N/A	N/A	N/A	36.3	6.8	0.239	0.239
Bent 5	49.0	N/A	N/A	N/A	N/A	N/A	37.2	9.6	0.360	0.360
Bent 6	130.5	N/A	N/A	N/A	N/A	N/A	50.3	10.3	0.958	0.958
Bent 7	212.0	N/A	N/A	N/A	N/A	N/A	56.0	12.1	1.557	1.557
Bent 8	293.5	22	15	4.043	0.252	26.8	46.0	N/A	1.903	2.155
Bent 9	375.0	25	19	5.279	0.349	40.8	43.2	N/A	2.405	2.754

The summation of the shaded columns, Δ_{elast} and Δ_{ss} , must equal the total movement required, Δ_{temp} .

Bent 5 must be designed for the unbalanced temperature and shrinkage force.

$$(49.3 + 27.1 + 16.5 + 6.8) \text{ kips} = \mathbf{99.7 \text{ kips}} \quad \approx \quad (9.6 + 10.3 + 12.1 + 26.8 + 40.8) \text{ kips} = \mathbf{99.6 \text{ kips}}$$

Note that the thermal center of the structure is 49 feet to the left of the actual midpoint of the bridge (Bent 5). The bearings were originally designed assuming expansion from the actual midpoint of the bridge. An argument may be made that the bearings at Bents 8 and 9 need to be re-designed so that $t_{elast} \geq 2 \times$ the anticipated movement in one direction with the appropriate load factors for deformation. See current IIM-S&B-80. After re-design of the bearings, the temperature and shrinkage forces would need to be recalculated.

However, the original design did not account for flexibility of the substructure and since the deformation of the elastomeric pad is much less than originally designed for, the bearing designs are O.K. by inspection. Bearing re-design to take advantage of substructure flexibility is not recommended in this case as smaller bearings with less thickness would increase the already large forces on Bents 1 and 9.

Example continued on next sheet

PIER DETAILS SUPERSTRUCTURE FORCES EXAMPLE 3: PILE BENT

PART 2
DATE: 11Jan2011
SHEET 11 of 12
FILE NO. 15.04-11

EXAMPLE 3: PILE BENT (cont'd.):

The location of the thermal center of the bridge is of particular importance in this jointless bridge example. A design waiver was approved for this structure as it exceeds the selection criteria on File No. 20.01-1 for semi-integral bridges. To minimize any negative effects due to additional movement at Abutment B, the piles at Bent 5 were battered to ensure that the thermal center is as close to the actual center of the bridge as possible. The updated calculation table with Bent 5 as the thermal center is provided below.

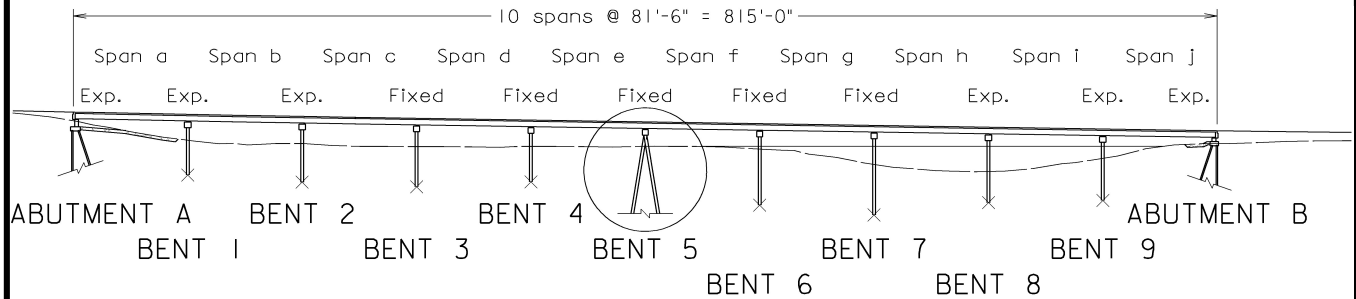

Calculation table (Scoured – Bent 5 battered)

Location	L	L _{elast}	W _{elast}	t _{elast}	Δ _{elast}	P _{elast}	H _{ss}	PSS	Δ _{ss}	Δ _{temp}
Bent 1	326.0	25	19	5.279	0.496	58.1	35.5	N/A	1.898	2.394
Bent 2	244.5	22	15	4.043	0.319	33.8	39.1	N/A	1.477	1.796
Bent 3	163.0	N/A	N/A	N/A	N/A	N/A	41.1	23.6	1.197	1.197
Bent 4	81.5	N/A	N/A	N/A	N/A	N/A	36.3	17.1	0.599	0.599
Bent 5	0.0	N/A	N/A	N/A	N/A	N/A	37.2	TBD	0	0
Bent 6	81.5	N/A	N/A	N/A	N/A	N/A	50.3	6.4	0.599	0.599
Bent 7	163.0	N/A	N/A	N/A	N/A	N/A	56.0	9.3	1.197	1.197
Bent 8	244.5	22	15	4.043	0.210	22.3	46.0	N/A	1.586	1.796
Bent 9	326.0	25	19	5.279	0.303	35.5	43.2	N/A	2.091	2.394

The summation of the shaded columns, Δ_{elast} and Δ_{ss}, must equal the total movement required, Δ_{temp}.

Bent 5 must be designed for the unbalanced temperature and shrinkage force.

$$(58.1 + 33.8 + 23.6 + 17.1) \text{ kips} = \mathbf{132.6 \text{ kips}} > (6.4 + 9.3 + 22.3 + 35.5) \text{ kips} = \mathbf{73.5 \text{ kips}}$$

$$\text{Unbalanced force} = 132.6 \text{ kips} - 73.5 \text{ kips} = 59.1 \text{ kips}$$

The non-scoured condition must also be modeled to ensure that the reduced lengths to the assumed POF do not control design. The non-scoured results are not provided for this example.

GENERAL INFORMATION:

AASHTO LRFD specifications, Article 11.7.2.1, require “Where the possibility of collision exists from highway and river traffic, an appropriate risk analysis should be made to determine the degree of impact resistance to be provided and/or the appropriate protection system.”

This section specifies the general practices and requirements regarding pier protection for vehicular collision. Pier protection for vessel collision shall conform to the requirements specified in AASHTO LRFD specifications, Article 3.14.

For consistency, Edge of traffic lane will be used for other interchangeable terminologies in this chapter, see the following sketch and Reference Clarification.

Reference Clarification:

The point of reference for the 30'-0" measurement is to the edge of permanent traffic thru lane indicated in the adjacent sketch as Edge of traffic lane and Edge of traveled way (roadway).

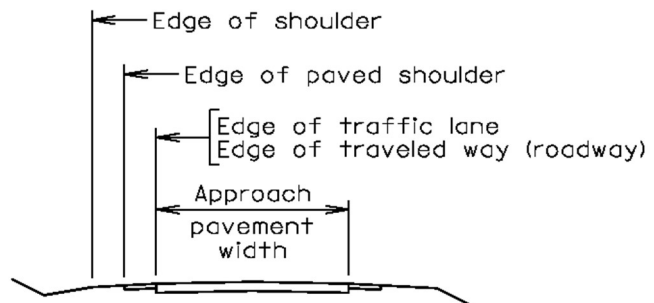

For New Construction or Bridge Replacement:

The requirement for pier protection shall adhere to the following hierarchy:

1. Locate pier > 30'-0" from edge of traffic lane where feasible to mitigate vehicular collision.
2. Design pier for collision force as specified in AASHTO LRFD specifications, Article 3.6.5 if
 - a. Design year Average Daily Truck Traffic (ADTT) in one direction is ≥ 400 for undivided roadways and ≥ 1200 for divided roadways; or
 - b. Design year ADTT in one direction is < 400 for undivided roadways and < 1200 for divided roadways, when (in discussion with the L&D/Traffic Engineer)
 - (i) History of crashes exists; or
 - (ii) Where fill slopes and vertical alignment makes recovery not possible (non-traversable) for vehicles. (In situations, in which the embankment slopes significantly downward, a vehicle could encroach closer to the pier and farther from the through traveled way and the clear zone might not be adequate.)

When a pier is designed for collision force, different types of piers (File No. 15.01-1) shall be compared to achieve the most cost effective and sound engineering solution. For example, a wall pier may be more cost effective than multi-column pier when collision force is taken into account.

Pier protection may be used in lieu of designing for collision forces if the resulting pier design is more expensive compared to providing pier protection. (Cost of pier protection shall include the barrier required, transition section, standard terminal and/or impact attenuator. Cost for designing a pier for vehicle collision shall include additional cost for pier designed for vehicle collision and guardrail when pier is within roadway clear zone.)

PIER DETAILS PIER PROTECTION SYSTEM GENERAL INFORMATION

PART 2
DATE: 18May2016
SHEET 1 of 19
FILE NO. 15.06-1

For Existing Bridge Piers:

The requirement of pier protection shall be evaluated in accordance with AASHTO LRFD Specifications, Article 3.6.5. If the pier is located less than 30'-0" from the edge of traffic lane, the requirement for pier protection shall adhere to the following hierarchy:

1. Evaluate whether the pier can resist the collision force as specified in AASHTO LRFD specifications, Article 3.6.5 if
 - a. Design year ADTT in one direction is ≥ 400 for undivided roadways and ≥ 1200 for divided roadways; or
 - b. Design year ADTT in one direction is < 400 for undivided roadways and < 1200 for divided roadways, when (in discussion with the L&D/Traffic Engineer)
 - (i) History of crashes exists or
 - (ii) Where fill slopes and Vertical alignment makes recovery not possible (non-traversable) for vehicles. (In situations, in which the embankment slopes significantly downward, a vehicle could encroach closer to the pier and farther from the through traveled way and the clear zone might not be adequate.)
2. If evaluating whether the pier can resist the collision force is required (from 1 above) and the pier cannot resist the collision force, use a bridge pier protection system (BPPS Standards).

Additional Requirements:

A bridge pier protection system (BPPS Standards) shall always be used when standard MB-7F traffic barrier is required by traffic design, in which case, design of pier for collision force is not required for new construction or structural evaluation is not necessary for existing piers.

Straddle bents shall be designed for collision force as well as protected with a bridge pier protection system (BPPS Standards).

Maintenance of Traffic, which temporarily routes traffic close to a pier during a fixed construction contract duration, does not require bridge pier protection system (BPPS). Temporary pier protection shall conform to requirements for protection of other fixed objects.

Pier protection using barrier has the following requirements (AASHTO):

1. Crashworthy ground mounted, Test Level 5.
2. 54" high barrier when located within 12'-0" from the pier being protected.
3. 42" high barrier when located $\geq 12'-0"$ and $< 30'-0"$ from the pier being protected.

NOTE: The 12'-0" is set from the face of pier to the face of barrier curb while the 30'-0" is set from the face of pier to the edge of traffic lane.

The Structure and Bridge Division has developed standards to meet the barrier requirements noted above. These standards are included in Part 3 of this manual.

If any part of the protected pier is located within 12'-0" from the face of barrier curb, 54" high barrier, Standard BPPS-1A and BPPS-2A, shall be used for the full length. The barrier transition from 42" to 54" and the 42" terminal barrier are additional if needed.

If the entire protected pier is located at or beyond 12'-0" and less than 30'-0" from the face of barrier curb, 42" high barrier, Standard BPPS-3A and BPPS-4A, shall be used for the full length. 42" terminal barrier is additional if needed.

PIER DETAILS PIER PROTECTION SYSTEM GENERAL INFORMATION

PART 2
DATE: 30Oct2020
SHEET 2 of 19
FILE NO. 15.06-2

Additional Requirements (continued):

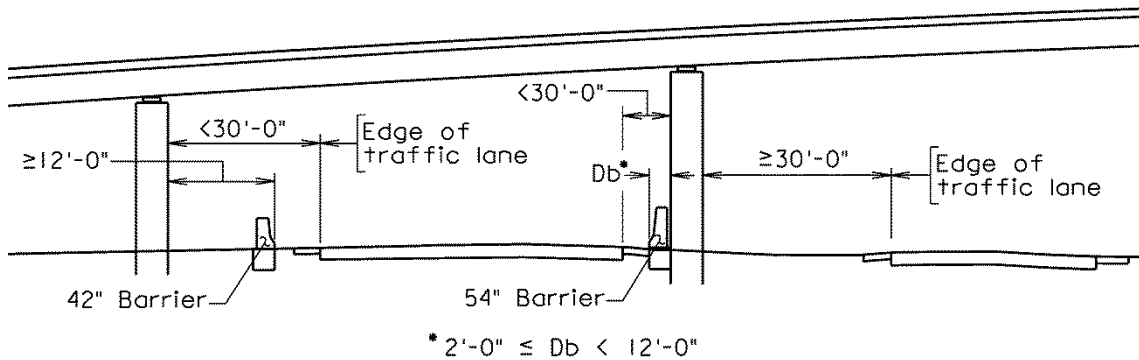

The face of the barrier curb shall align with the guardrail offset for the roadway classification where sufficient clearance is available. The minimum distance from the edge of traffic lane to the face of the barrier curb shall be 2'-0". The preferred minimum distance from the face of the barrier curb is 5'-0" to the face of the protected pier to keep out of the zone of intrusion. Barrier shall be aligned parallel to the edge of traffic lane. Drainage should be taken into account for long pier protection barriers.

The absolute minimum distance from the edge of traffic lane to the face of a pier column or pier stem is 4'-0".

- 2'-0" minimum distance from edge of traffic lane to face of barrier curb
- 1'-8" barrier width at base
- 4" distance from back of barrier to back of barrier footing
- 4'-0" = minimum distance from edge of traffic lane to face of pier column/stem

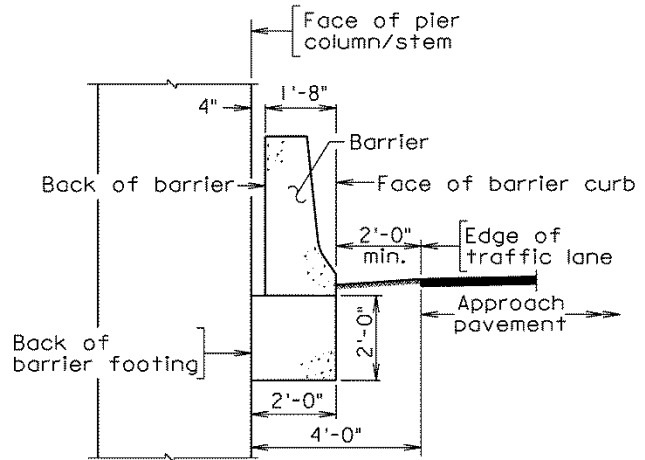

In this case, the back of barrier footing would be cast against the pier column/stem face. This requires the pier footing to be sufficiently depressed to clear the barrier footing.

Where traffic is on both sides of the pier and at differing elevation, top of pier footing elevation shall be based on the lower roadway elevation.

**PIER DETAILS
PIER PROTECTION SYSTEM
GENERAL INFORMATION**

PART 2
DATE: 18May2016
SHEET 3 of 19
FILE NO. 15.06-3

LENGTH OF PIER PROTECTION:

The length of pier protection system shall be determined as follows.

Notation:

PO – Intersection of the centerline of pier and the edge of the overpass bridge deck.

PA – Controlling point, either of PA1/PA3 or PA2, whichever is approached first in the direction of traffic. For one-directional traffic, it is on the run-on end. For two-directional undivided traffic, it is on the run-on end for the traffic adjacent to barrier, meanwhile on the run-off end for the opposite traffic.

PB – Controlling point, either of PB1/PB3 or PB2, whichever is approached first in the direction of traffic. For one-directional traffic, it is on the run-off end. For two-directional undivided traffic, it is on the run-off end for the traffic adjacent to barrier, meanwhile on the run-on end for the opposite traffic.

Where: PA1 and PB1 or PA3 and PB3 are the intersection of edge of traffic lane and edge of deck depending on the orientation of deck.

PA2 and PB2 are the intersection of edge of traffic lane and a line through PO perpendicular to edge of traffic lane.

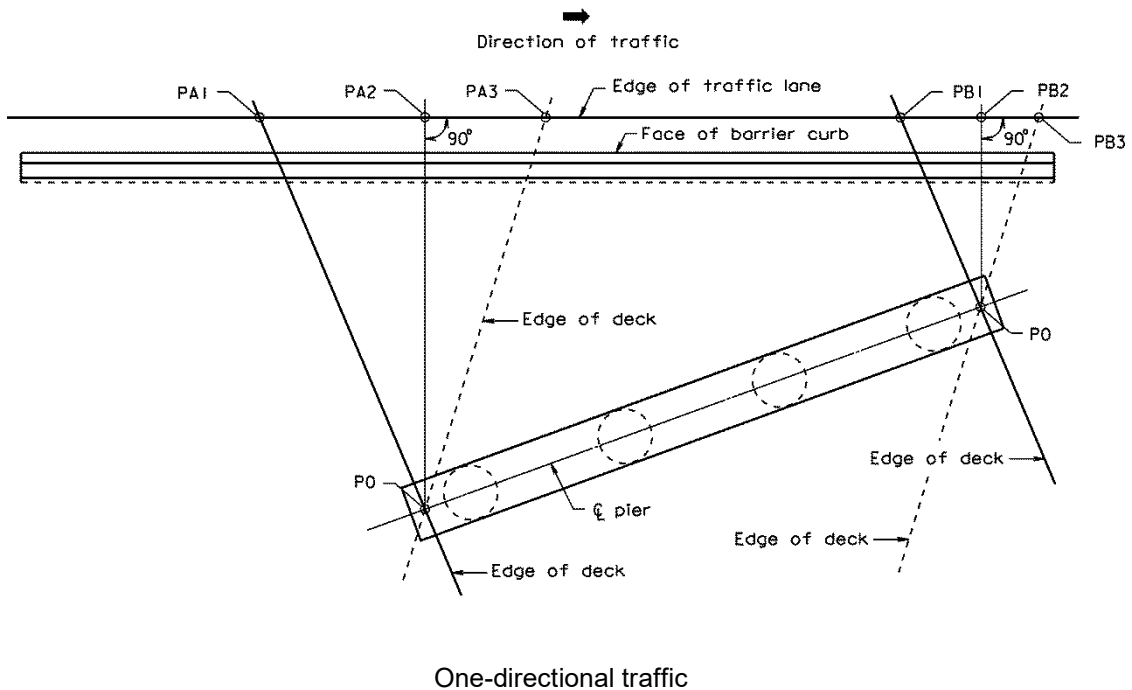

PIER DETAILS PIER PROTECTION SYSTEM LENGTH OF PIER PROTECTION

PART 2
DATE: 18May2016
SHEET 4 of 19
FILE NO. 15.06-4

LENGTH OF PIER PROTECTION (continued):

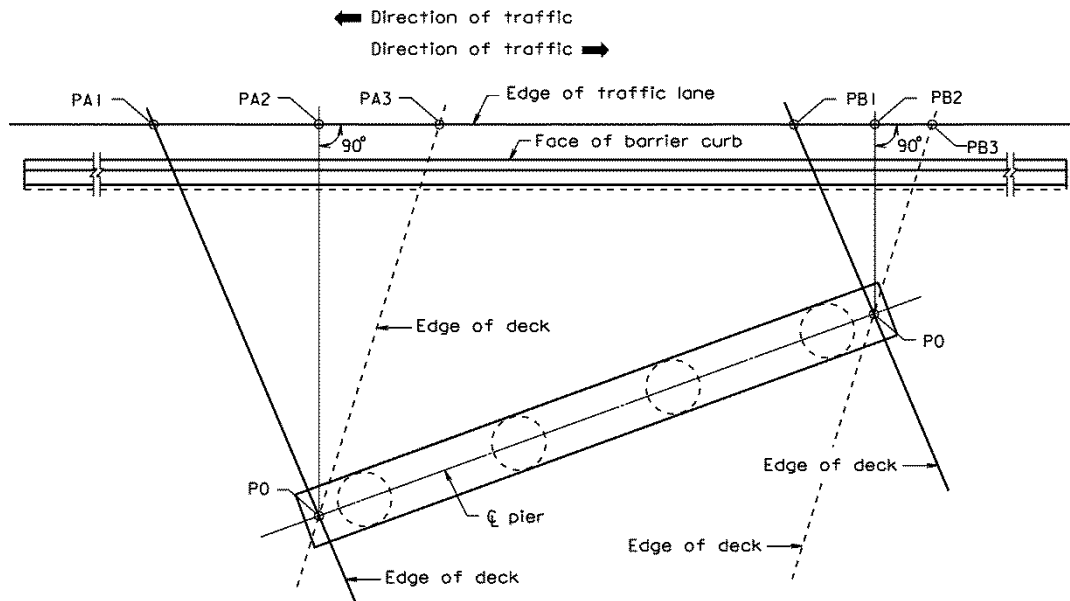

Two-directional undivided traffic

For one-directional traffic on one side of the pier (including two-directional divided traffic):

The minimum length of pier protection system shall be the sum of the following components:

- 1) 30' on run-on end to PA (plus barrier transition and terminal section as needed);
- 2) Projected distance between PA and PB;
- 3) 5' from PB on run-off end.

For two directional undivided traffic on one side of the pier:

The minimum length of barrier protection shall be the sum of the following components:

- 1) 30' on run-on end to PA (plus barrier transition and terminal section as needed). PA is determined using direction of traffic adjacent to barrier;
- 2) Projected distance between PA and PB;
- 3) 30' from PB on run-on end (plus barrier transition and terminal section as needed). PB is determined using direction of traffic opposite to the traffic adjacent to barrier.

When traffic is on both sides of the pier, the noted requirements apply to both sides.

LENGTH OF PIER PROTECTION (continued):

For hammerhead piers, if any point along the pier arm has a vertical clearance less than 16'-6", use edge of deck to determine PA and PB, otherwise use face of pier stem to determine PA and PB. For instance, in the following figure, the lines parallel to the edge of deck through Points PC1 and PC2 may be used to replace the edge of deck for the purpose of determining the length of barrier. Also PC1 or PC2 may be used to replace PO for determining the length of barrier for all the applicable cases.

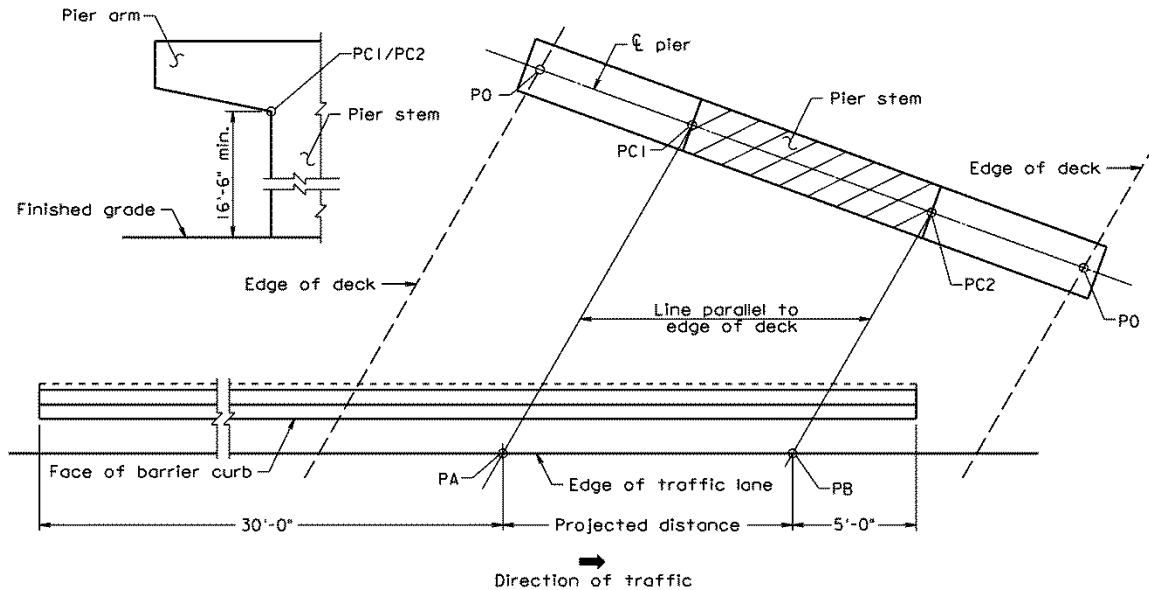

For straddle bents, the length of barrier shall be determined with the following scheme.

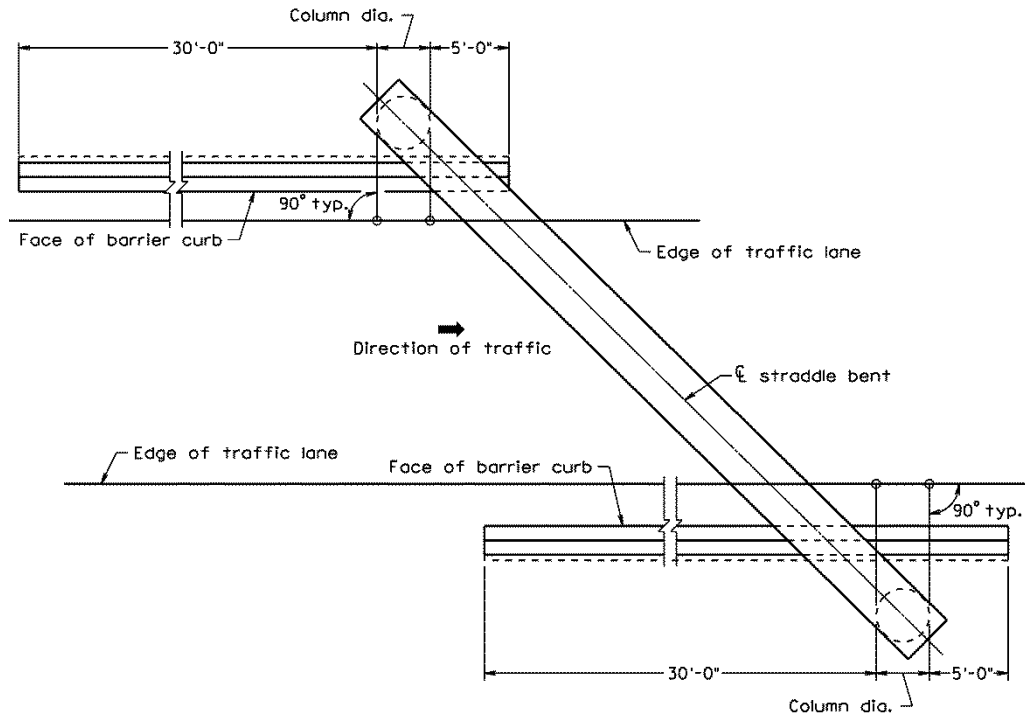

PIER DETAILS PIER PROTECTION SYSTEM LENGTH OF PIER PROTECTION

PART 2
DATE: 18May2016
SHEET 7 of 19
FILE NO. 15.06-7

The following examples illustrate what types of pier protection system and what lengths shall be used.

EXAMPLE 1:

Traffic is on one side of the pier and the CL pier and CL roadway are parallel. The 3-column pier consists of 4'-0" diameter columns with 18'-0" column spacing. The columns are designed for the collision force. Clearances from the edge of traffic lane to pier column are as shown. ST'D GR-2 guardrail is required by roadway design.

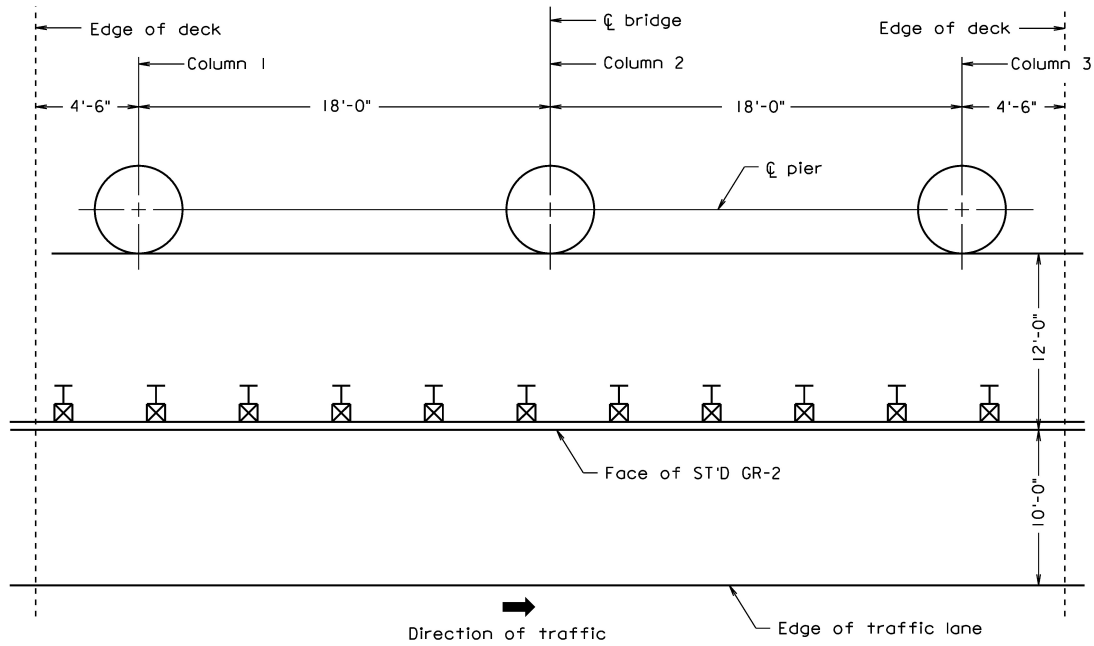

Since the pier columns are designed for the collision force and MB-7F is not required by roadway design, pier protection is not required. The ST'D GR-2 guardrail is installed according to roadway design.

**PIER DETAILS
PIER PROTECTION SYSTEM
BARRIER LAYOUT EXAMPLE 1**

PART 2
DATE: 18May2016
SHEET 8 of 19
FILE NO. 15.06-8

EXAMPLE 2:

One-directional divided traffic is on one side of the pier and the ℓ pier and ℓ roadway are parallel. The 3-column pier consists of 4'-0" diameter columns with 18'-0" column spacing. ADTT in one direction is 500. The columns are designed for the collision force. Clearances from the edge of traffic lane to pier column are as shown. MB-7F traffic barrier is required by roadway design.

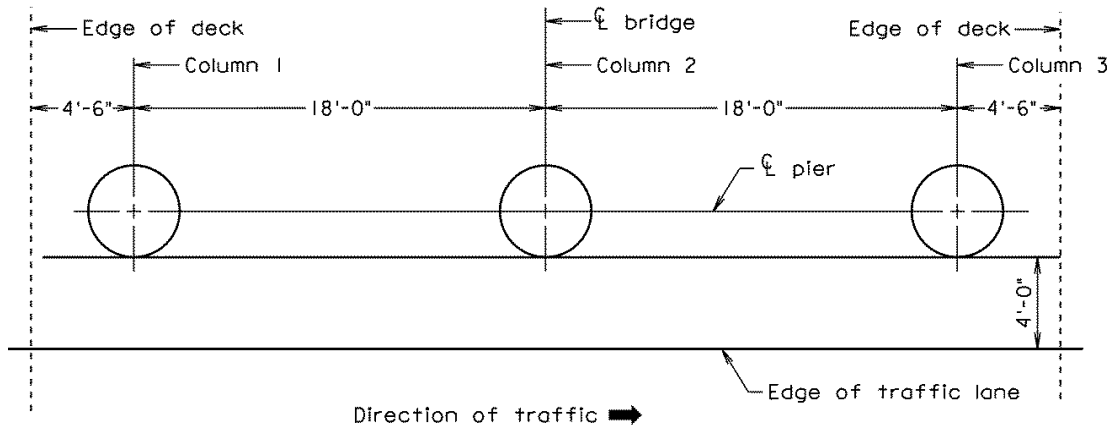

Even though the pier columns are designed for the collision force, pier protection is required as MB-7F traffic barrier is required by roadway design. The distance from the edge of traffic lane to the face of barrier curb is 2'-0" and also coincides with the guardrail offset for the roadway classification involved.

The clearance from the face of barrier curb to the face of pier column: 4'-0" - 2'-0" = 2'-0", which is < 12'-0". Therefore a 54" barrier is required and Standards BPPS-1A and -2A will be used.

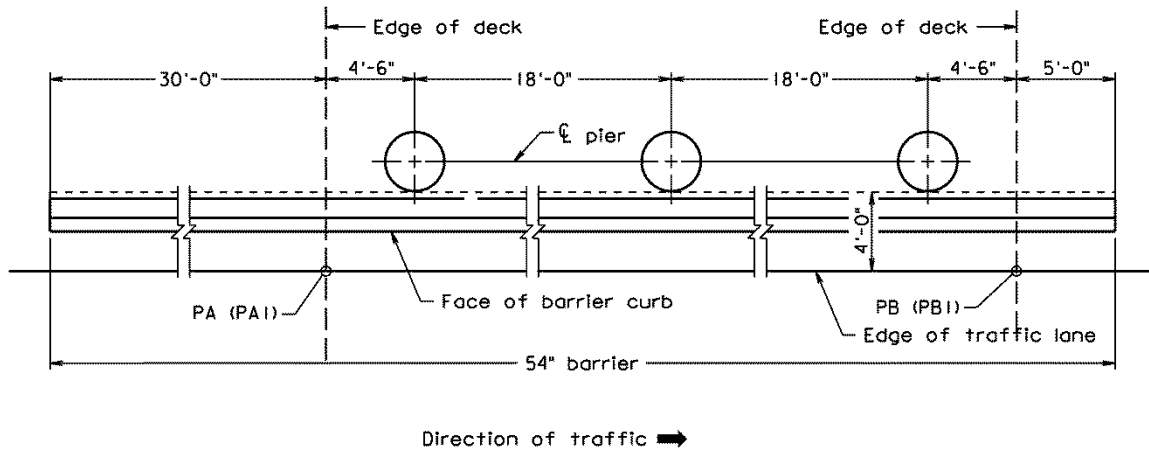

**PIER DETAILS
PIER PROTECTION SYSTEM
BARRIER LAYOUT EXAMPLE 1**

PART 2
DATE: 30Oct2020
SHEET 9 of 19
FILE NO. 15.06-9

EXAMPLE 2 (continued):

Because the edge of deck is perpendicular to the edge of traffic lane, PA is PA1 which coincides with PA2. PB is PB1 which coincides with PB2. The length of 54" barrier is:

$$L_{\text{barrier}} = 30'-0" + (4'-6" + 18'-0" + 18'-0" + 4'-6") + 5'-0" = 80'-0"$$

Add 13'-0" terminal section for guardrail and 6'-0" transition section from 42" to 54" on run-on side.

Add LAYOUT OF BARRIER FOR PIER PROTECTION to standard sheet. Show length for 54" high barrier and 42" to 54" transition section as well as 42" terminal section. Add lengths to PLAN and ELEVATION, stations to PLAN on standard sheet.

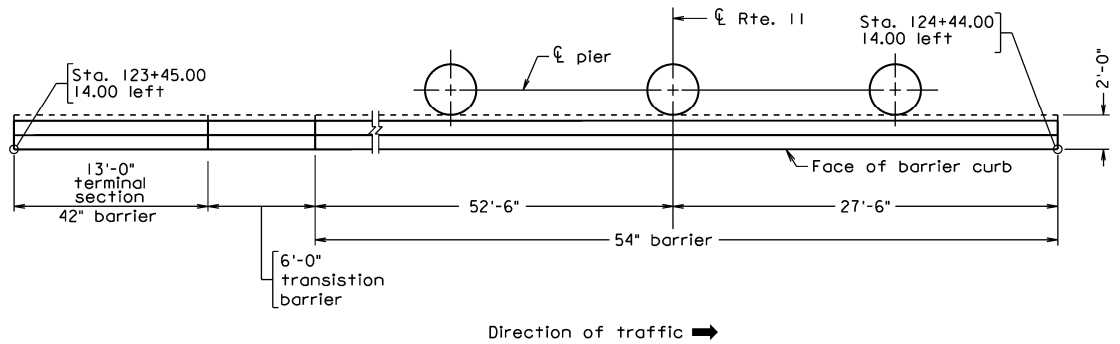

LAYOUT OF BARRIER FOR PIER PROTECTION

EXAMPLE 3 (continued):

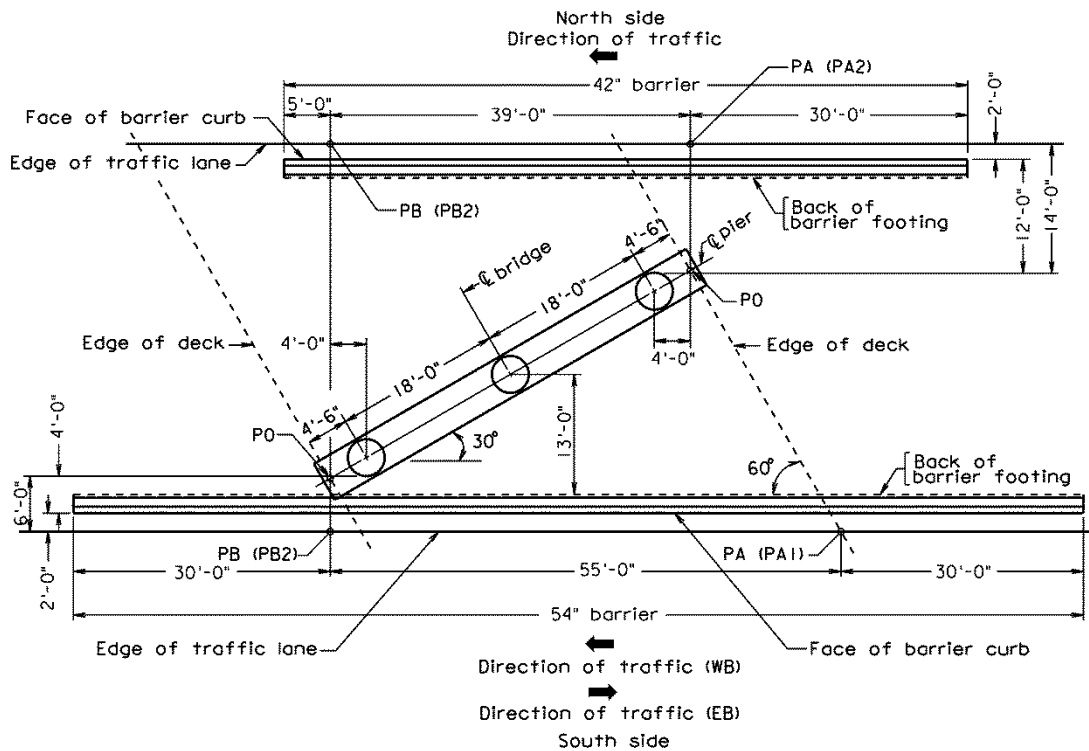

North side:

Since there is one-directional traffic on the north side, PA2 is approached first on the run-on end (PA2 is PA) and PB2 is approached first on the run-off end (PB2 is PB). The length of 42" barrier is:

$$L_{\text{barrier}} = 30'-0'' + 39'-0'' + 5'-0'' = 74'-0''$$

South side:

There is two-directional traffic on the south side. PA1 is approached first on WB traffic direction for lane adjacent to barrier (PA1 is PA) and PB2 is approached first on EB traffic direction (PB2 is PB). The length of 54" barrier is:

$$L_{\text{barrier}} = 30'-0'' + 55'-0'' + 30'-0'' = 115'-0''$$

Add 7'-3" terminal section for guardrail on run-on end at the north side.

Add 7'-3" terminal section for guardrail and 6'-0" transition barrier from 42" to 54" at both ends at the south side.

Add LAYOUT OF BARRIER FOR PIER PROTECTION to standard sheet. Show length for 42" high barrier and terminal section on the north side. Show length for 54" high barrier and terminal section as well as transition from 42" to 54" on the south side. Add lengths to PLAN and ELEVATION, stations to PLAN on standard sheet.

**PIER DETAILS
PIER PROTECTION SYSTEM
BARRIER LAYOUT EXAMPLE 3**

PART 2
DATE: 18May2016
SHEET 12 of 19
FILE NO. 15.06-12

EXAMPLE 3 (continued):

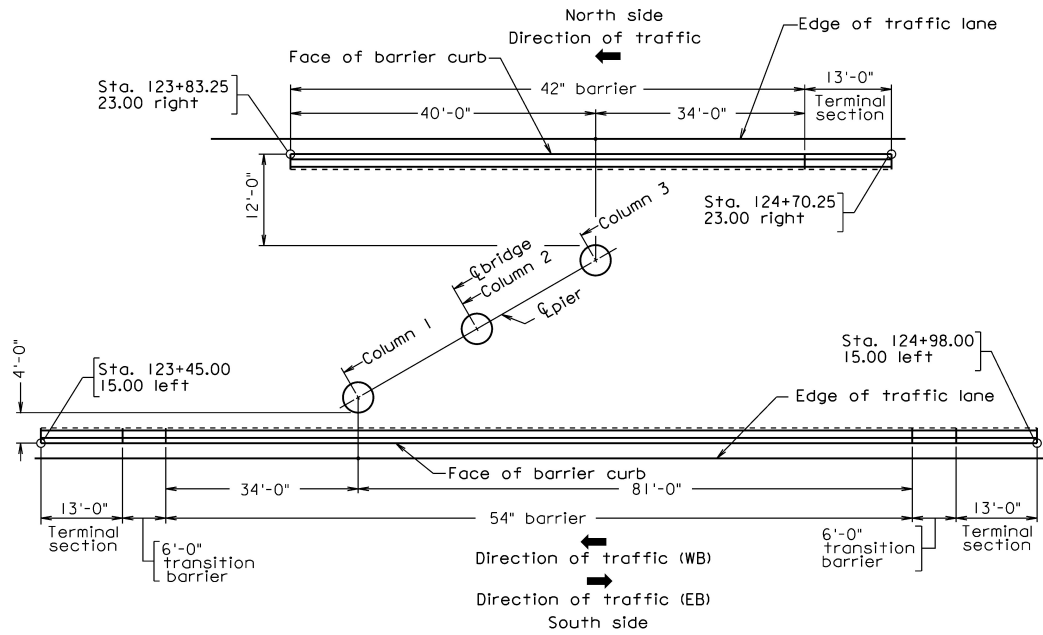

LAYOUT OF BARRIER FOR PIER PROTECTION

**PIER DETAILS
PIER PROTECTION SYSTEM
BARRIER LAYOUT EXAMPLE 3**

PART 2
DATE: 30Oct2020
SHEET 13 of 19
FILE NO. 15.06-13

EXAMPLE 4:

Two-directional undivided traffic is under an existing straddle bent. One-directional traffic is outside of the straddle bent at the south side. ADTT in one direction is 420. The straddle bent is 45° skewed to the edge of traffic lane. The columns have a diameter of 4'-0". The center to center distance between the columns is 68'-0". The width of straddle beam is 4'-6". Clearances from the edge of traffic lane to the columns are as shown.

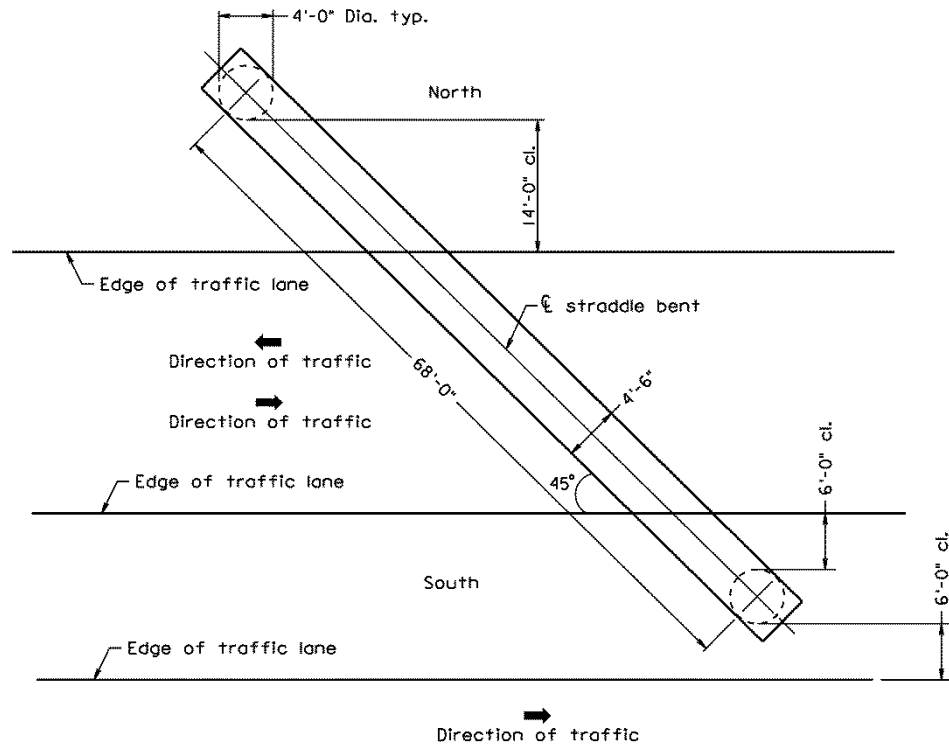

The analysis for the existing columns indicates that the columns can resist the collision force. Pier protection is still required for both columns of the straddle bent as they are < 30' from the edge of traffic lane.

For the purposes of this example, the minimum 2'-0" distance from the edge of traffic lane to the face of barrier curb also coincides with the guardrail offset for the roadway classification involved. The width of barrier footing is 2'-0".

The face of barrier curb is set 2'-0" from the edge of traffic lane to match the guardrail offset for the roadway classification involved.

The clearance from the face of barrier curb to the face of columns:

$$\text{North side under the straddle bent: } 14'-0" - 2'-0" = 12'-0"$$

$$\text{South side under the straddle bent: } 6'-0" - 2'-0" = 4'-0"$$

$$\text{Outside of the straddle bent: } 6'-0" - 2'-0" = 4'-0"$$

PIER DETAILS PIER PROTECTION SYSTEM BARRIER LAYOUT EXAMPLE 4

PART 2
DATE: 18May2016
SHEET 14 of 19
FILE NO. 15.06-14

EXAMPLE 4 (continued):

The shortest distance from the face of barrier curb to the column on north side under the straddle bent = 12'-0", therefore a 42" barrier is sufficient and Standard BPPS-3 will be used. The shortest distance from the face of barrier curb to the column on south side under the straddle bent and outside of the straddle bent < 12'-0", so a 54" barrier is required for the south side.

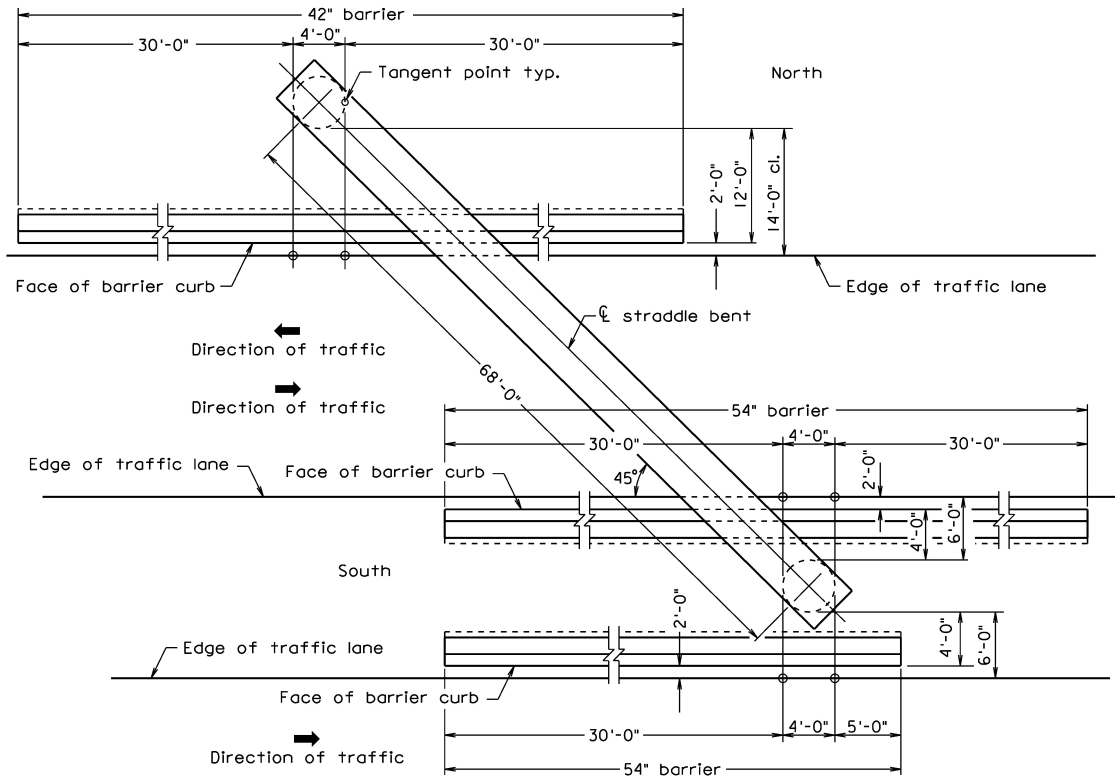

The length of barrier under the straddle bent is determined as shown in the above figure for two-directional traffic.

$$L_{\text{barrier_in}} = 30'-0" + 4'-0" + 30'-0" = 64'-0"$$

The length of barrier outside of the straddle bent is

$$L_{\text{barrier_outside}} = 30'-0" + 4'-0" + 5'-0" = 39'-0"$$

Add 13'-0" terminal section for guardrail on both of ends of 42" high barrier at the north side under the straddle bent.

Add 13'-0" terminal section for guardrail and 6'-0" transition barrier from 42" to 54" on both ends of 54" high barrier at the south side under the straddle bent.

EXAMPLE 4 (continued):

Add 13'-0" terminal section for guardrail and 6'-0" transition barrier from 42" to 54" on the run-on side of 54" high barrier at the outside of the straddle bent.

Add LAYOUT OF BARRIER FOR PIER PROTECTION to standard sheet. Show terminal section and lengths for 42" high barrier. Show terminal section and lengths, and 6'-0" barrier transition for 54" high barrier. Add lengths to PLAN and ELEVATION, stations to PLAN on standard sheet.

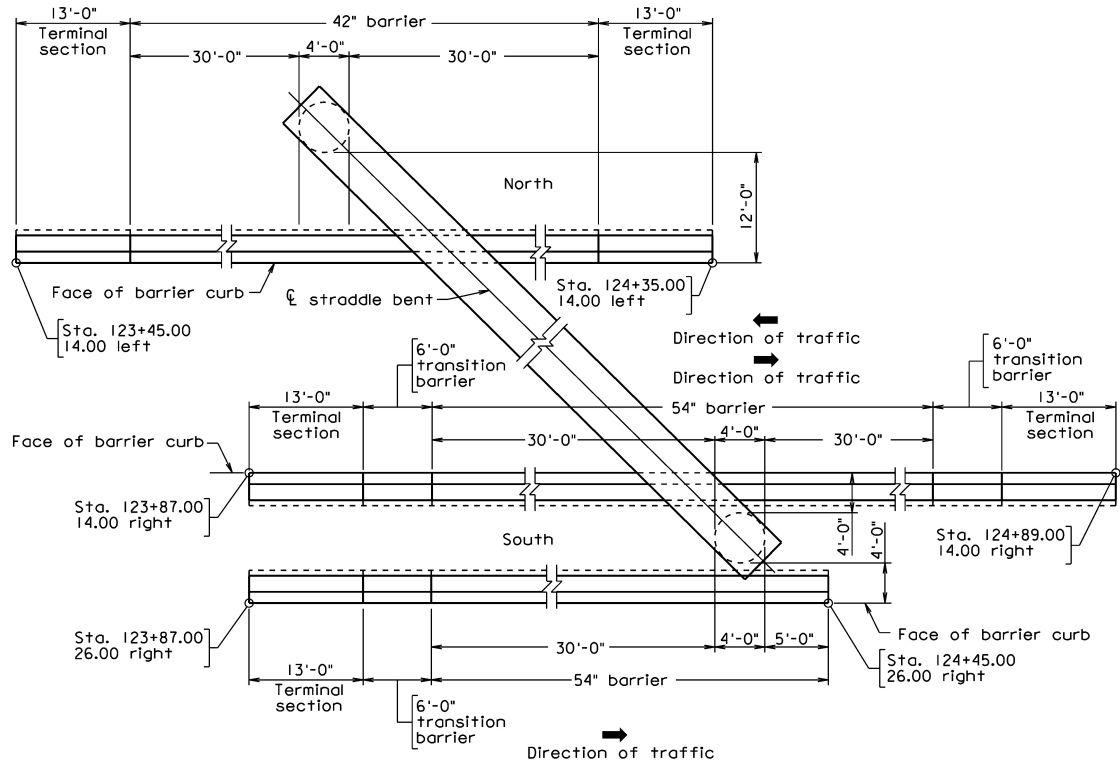

LAYOUT OF BARRIER FOR PIER PROTECTION

**PIER DETAILS
PIER PROTECTION SYSTEM
BARRIER LAYOUT EXAMPLE 4**

PART 2
DATE: 30Oct2020
SHEET 16 of 19
FILE NO. 15.06-16

EXAMPLE 5:

Two-directional undivided traffic is on one side of the existing pier. The roadway is on a curved alignment. ADTT in one direction is 200. There were several vehicle crashes in this location. Dimensions of the bridge deck and pier are as shown. Clearances from the edge of traffic lane to the columns are as shown.

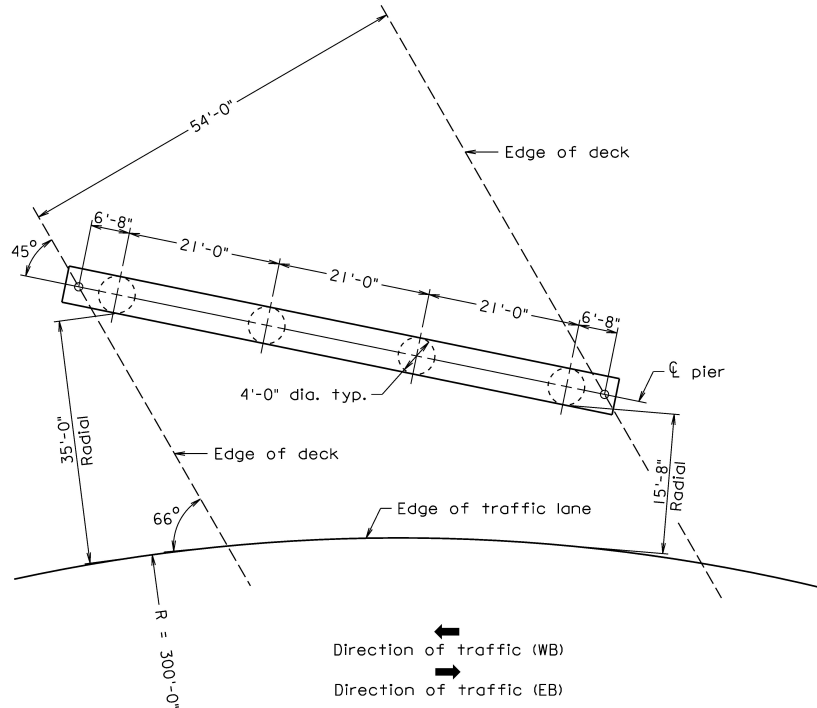

Although ADTT in one direction is < 400 , because of crash history, structural evaluation for the pier is required.

The analysis of the pier columns indicated that the columns cannot resist the collision force. Therefore pier protection is required.

The face of barrier curb is set 2'-0" from the edge of traffic lane to match the guardrail offset for the roadway classification involved.

The shortest distance from the face of barrier curb to the face of columns: $15'-8" - 2'-0" = 13'-8"$, which is $> 12'-0"$. Therefore a 42" high barrier is sufficient and Standards BPPS-3A, BPPS-4A will be used.

**PIER DETAILS
PIER PROTECTION SYSTEM
BARRIER LAYOUT EXAMPLE 5**

PART 2
DATE: 30Oct2020
SHEET 17 of 19
FILE NO. 15.06-17

EXAMPLE 5 (continued):

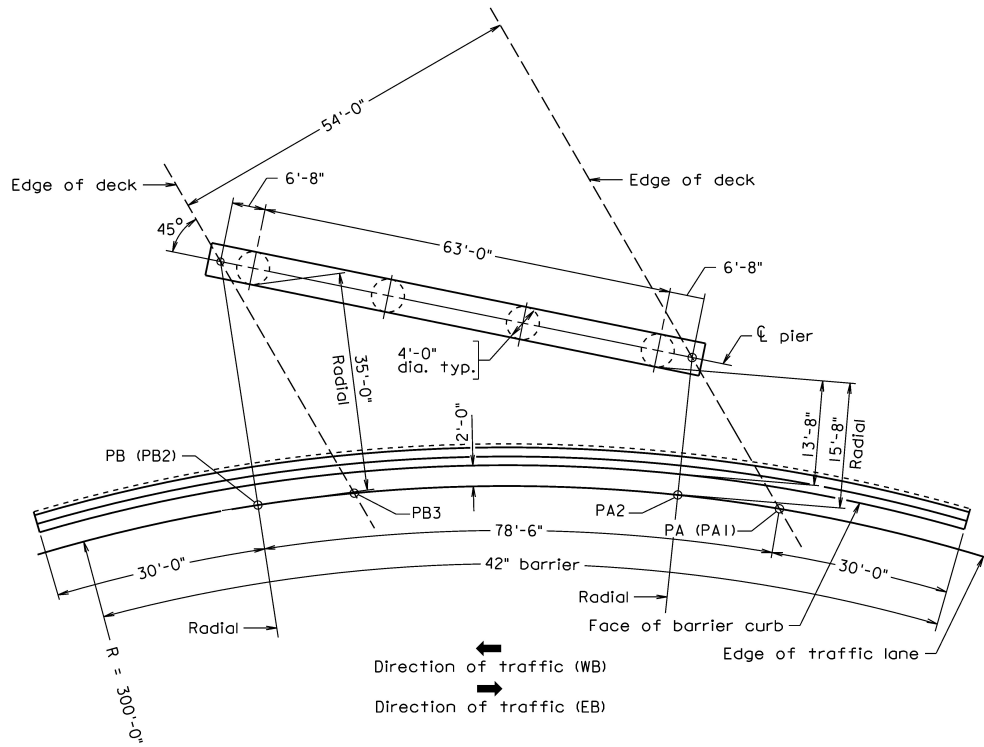

This is a two-directional traffic case. PA1 is approached first on WB traffic direction for lane adjacent to barrier (PA1 is PA) and PB2 is approached first on EB traffic direction (PB2 is PB). The length of 42" barrier is:

$$L_{\text{barrier}} = 30'-0" + 78'-6" + 30'-0" = 138'-6", \text{ use } 139'-0".$$

Add 13'-0" terminal section for guardrail on both sides.

Add LAYOUT OF BARRIER FOR PIER PROTECTION to standard sheet. Show length for 42" high barrier and terminal section. Add lengths to PLAN and ELEVATION, stations to PLAN on standard sheet.

**PIER DETAILS
PIER PROTECTION SYSTEM
BARRIER LAYOUT EXAMPLE 5**

PART 2
DATE: 30Oct2020
SHEET 18 of 19
FILE NO. 15.06-18

EXAMPLE 5 (continued):

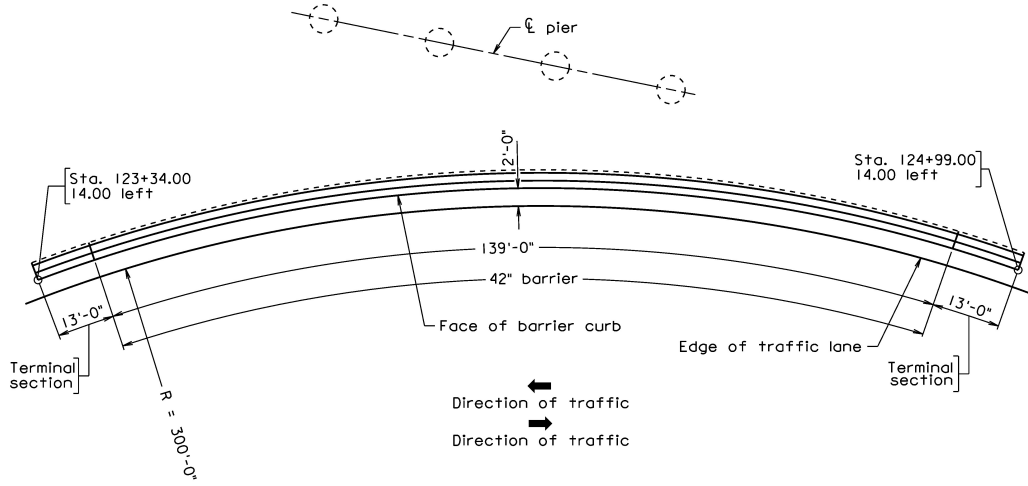

LAYOUT OF BARRIER FOR PIER PROTECTION